

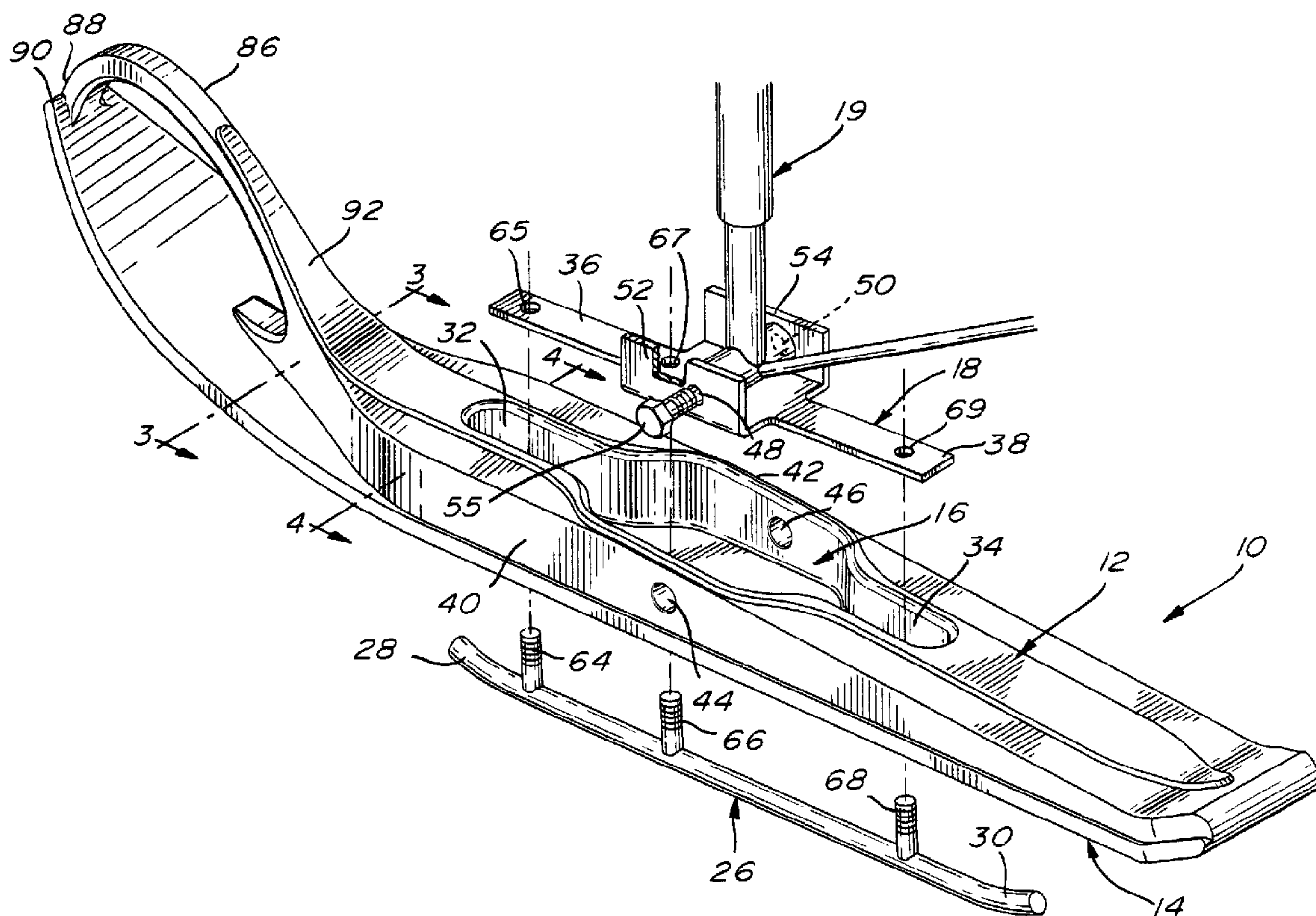

(22) Date de dépôt/Filing Date: 1997/01/15
(41) Mise à la disp. pub./Open to Public Insp.: 1998/07/15
(45) Date de délivrance/Issue Date: 2001/08/21

(51) Cl.Int.⁶/Int.Cl.⁶ B62B 17/02
(72) Inventeurs/Inventors:
KHENNACHE, OMAR, CA;
Beaulieu, Nelson, CA;
Chapdelaine, Jérôme, CA
(73) Propriétaire/Owner:
CAMOPLAST INC., CA
(74) Agent: GOUDREAU GAGE DUBUC

(54) Titre : SKI DE DIRECTION POUR MOTONEIGE
(54) Title: SNOWMOBILE STEERING SKI



(57) Abrégé/Abstract:

A snowmobile steering ski consists of an elongated one-piece blow molded body formed of polyethylene, preferably ultra high molecular weight polyethylene. The top wall of the body has raised portions defining hollow sections with the bottom wall and displays a central recessed area adapted to receive the lower end of a snowmobile steering component. A pair of fixation holes are provided in lateral sides of the recessed area for fixing the steering component to the ski while further fixation holes are provided in the bottom of the recessed area for fixing a wear bar to the under face of the body.

2195166

ABSTRACT

A snowmobile steering ski consists of an elongated one-piece blow molded body formed of polyethylene, preferably ultra high molecular weight polyethylene. The top wall of the body has raised portions defining hollow sections with the bottom wall and displays a central recessed area adapted to receive the lower end of a snowmobile steering component. A pair of fixation holes are provided in lateral sides of the recessed area for fixing the steering component to the ski while further fixation holes are provided in the bottom of the recessed area for fixing a wear bar to the under face of the body.

TITLE OF THE INVENTION

Snowmobile steering ski.

FIELD OF THE INVENTION

5 The present invention pertains to a ski used for the steering of a snowmobile. More particularly, the present invention pertains to a one piece blow molded ski formed of polyethylene.

BACKGROUND OF THE INVENTION

10 Generally, snowmobile skis are made of metal, such as steel or aluminum. Snowmobile metal skis are found to show a higher wear than that of any kind of plastic skis and, when wear is important, snowmobile performance is significantly reduced. Metal skis have a tendency to stick onto the ice which thereby significantly increases friction forces which shorten the life of skis. This induces a higher drag between the metal skis and the ice, which leads to higher gas consumption. Also, the appearance
15 of a worn metal ski depreciates its value.

In the last decade, many plastic ski designs have been developed and fabricated. Such skis may be found described in U.S. patent 5,040,818 issued August 20, 1991 to Metheny, U.S. patent 5,165,709 issued November 24, 1992 to Jacques and U.S. patent 5,443,278 issued August 22,
20 1995 to Berto. It has been found that plastic skis show better overall riding performance than metal skis. All presently known plastic skis are produced using a process called compression molding with ultra high molecular weight polyethylene (UHMW-PE), which process has long production cycles. Compression molded plastic skis are much more expensive than metal skis
25 because of this longer production cycle and of design limitations, such as wall thickness. Heavy metal frame works must be added to the ski skin for

extra strength. However, upon front impact on these plastic skis, the metal frame works deform permanently, which results in the need to replace them.

Also, metal and plastic skis presently used require the incorporation of a separate handle to the overall assembly. In the above
5 mentioned patent 5,165,709, the compression molded plastic ski has its front handle as part of the sole; however, an additional assembly operation is needed to bend back the handle and secure it to the sole end stiffener.

OBJECTS AND STATEMENT OF THE INVENTION

10 It is an object of the present invention to provide a snowmobile ski which overcomes the disadvantages and limitations of presently known methods of making plastic snowmobile skis by the compression molding process.

15 It is a further object of the present invention to provide a snowmobile steering ski which is lighter than presently used plastic end metal skis.

It is an other object of the present invention to provide a plastic snowmobile ski made by blow molding and wherein a handle is completely integrated to the assembly thereby eliminating assembly operations which are required in presently known metal and plastic skis.

20 The present invention therefore relates to a snowmobile ski which comprises an elongated one-piece blow molded body formed of polyethylene; the blow molded body has a top wall and a bottom wall with areas spaced from one another to define an enclosed empty space; the top wall displays opposite laterally spaced raised hollow portions in the central

region of the body to define a central recessed area adapted to receive therein the lower end of a snowmobile steering component; first fixation hole means are provided in the laterally spaced raised hollow portions for fixing the steering component to the ski.

5 In one form of the invention, the body has a forward end and defines a hollow handle having one end integrally formed with this forward end and an opposite end contiguous with the enclosed empty space of the ski.

 In another form of the invention, second fixation holes are provided, during the blow molding process, in the bottom of the recessed area
10 for fixing a wear bar to the under face of the body.

 One preferred material is ultra high molecular weight polyethylene (UHMW-PE).

 Other objects and further scope of applicability of the present invention will become apparent from the detailed description given hereinafter.
15 It should be understood, however, that this detailed description, while indicating preferred embodiments of the invention, is given by way of illustration only, since various changes and modifications within the spirit and scope of the invention will become apparent to those skilled in the art.

BRIEF DESCRIPTION OF THE DRAWINGS

20 Figure 1 is a perspective exploded view showing a ski made in accordance with the present invention together with some of the steering components of a snowmobile and a wear bar;

 Figure 1a is a perspective exploded view showing another suspension plate which may be used with the ski of the present invention;

Figure 2 is a longitudinal cross sectional view of the ski;

Figure 3 is a cross sectional view taken along lines 3-3 of figure
1;

Figure 4 is a cross sectional view taken along lines 4-4 of figure
5 1; and

Figure 5 is a cross sectional view taken along lines 5-5 of figure
4.

DETAILED DESCRIPTION OF THE INVENTION

Referring to figure 1, there is shown a ski 10 which is used,
10 either singly or in pair, for turning or steering a snowmobile (not shown). The
ski consists of a one-piece elongated body formed by a process, called blow
molding, using polyethylene such as high molecular weight polyethylene
(HMW-PE) or, preferably, ultra high molecular weight polyethylene (UHMW-
PE). Various additives may be used to improve wear resistance, including
15 those which are mentioned in the above noted U.S. patent 5,165,709.

Body 10 has a top wall 12 and a bottom wall 14. As a result of
the blow molding process, the top wall 12 is formed of raised portions with
respect to the bottom wall thereby defining hollow sections (as described
further hereinbelow). The top wall 12 displays a central recessed area 16 to
20 receive therein a suspension plate 18 forming part of the steering
components 19 of the snowmobile.

Referring also to figures 2, 4 and 5, the bottom wall 14 has a
narrow concave surface with opposite entering areas 22 and 24 to receive

a correspondingly shaped wear bar 26 with its opposite end portions 28 and 30.

5 The central recessed area 16 of the top wall has front and rear portions 32 and 34 in which are received corresponding front and rear end portions 36 and 38 of the metallic plate 18. The central recessed area 16 also defines opposite sides 40 and 42, each having a corresponding hole 44, 46, which is axially aligned with a corresponding hole 48, 50 provided in ears 52 and 54 of the plate. A pair of bolts (one being shown as 55) is used to secure the steering components to the ski. The bottom wall 56 of the
10 recessed area 16 has three aligned holes 58, 60 and 62 allowing to receive therethrough threaded projections 64, 66 and 68 of the wear bar 26. The suspension plate also has three holes 65, 67, 69 which are so disposed as to be aligned with the holes 58, 60, 62 and receive the projections 64, 66, 68 of the wear bar. Nuts (not shown) secure the wear bar and the plate to the
15 plastic ski.

As can be seen in figures 2, 3 and 4, the raised portions of the top wall 12 define hollow chambers, one of which is shown at the front end of the ski as 70, two of which are shown as 72 and 74 on each side of the recessed area 16, and a further, identified as 76, extending from the central
20 recessed area 16 to the rear extremity 78 of the ski.

The bottom wall 14 has a longitudinal central downward projection 80 defining opposite outside steering surfaces 82 and 84 to the ski. The bottom surface of this projection includes the concave bar receiving surface 20 described above.

25 An additional feature of the ski of the present invention due to its blow molding making is the provision of an integral handle portion 86 at

the forward end of the ski. As seen in figure 2, the handle is completely hollow with one area 88 integral with the front edge 90 of the ski and a rear area 92 defining a chamber 94 in communication with the chamber 70 of the central portion of the ski.

5 A preferred resin for the making of the ski of the present invention is polyethylene having a ultra high molecular weight. The tribologic features of this material, such as a coefficient of friction which is very low and a resistance to wear which is high, are known to be the best in the range of resins presently available on the market.

10 Figure 1a shows another metal plate 118 which may be used in lieu of plate 18; it comprises a pair of ears 152 and 154, each having a hole 148, 150 allowing the plate to be secured to the ski. The bottom wall of the plate has a hole 167 to secure the plate to the threaded projection 66 of the wear bar.

15 Although the invention has been described above with respect with one specific form, it will be evident to a person skilled in the art that it may be modified and refined in various ways. Because of the high molecular weight and viscosity of polyethylene, only special grades can be used for blow molding; however, some blend of polyethylene with polyamide, for
20 example, could be envisaged to form the body of the ski of the present invention. It is therefore wished to have it understood that the present invention should not be limited in scope, except by the terms of the following claims.

CLAIMS

1. A ski used for the steering of a snowmobile comprising: an elongated one-piece blow molded body formed of polyethylene; said blow molded body having a top wall and a bottom wall having areas spaced from one another to define an enclosed empty space; said top wall displaying opposite laterally spaced raised hollow portions in the central region of the body to define a central recessed area adapted to receive therein the lower end of a snowmobile steering component; and first fixation hole means in said laterally spaced raised hollow portions for fixing said steering component to said ski.

2. A ski as defined in claim 1, wherein said blow molded body has a forward end and defines a hollow handle having one end integrally formed with said forward end and an opposite end having an inner space contiguous with said enclosed empty space between said top and bottom walls.

3. A ski as defined in claim 1 or 2, wherein said blow molded body is formed of ultra high molecular weight polyethylene.

4. A ski as defined in claim 1, 2 or 3, comprising second fixation holes extending through said top and bottom walls for fixing in a bottom face of said bottom wall a wear bar to said body.

5. A ski as defined in claim 4, wherein said bottom wall has a central longitudinally extending projection; said projection displaying

opposite lateral steering surfaces and an elongated concavity to receive therein said wear bar.

6. A ski used for the steering of a snowmobile comprising: an elongated one-piece blow molded body formed of polyethylene; said body having a top wall and a bottom wall; said top wall having raised portions defining hollow sections with said bottom wall; said raised portions displaying a central recessed area adapted to receive therein the lower end of a snowmobile steering component; said recessed area defining opposite lateral sides; and first fixation hole means in said lateral sides for fixing said steering component to said ski.

7. A ski as defined in claim 6, wherein said body has a forward end and defines a hollow handle having one end integrally formed with said forward end and an opposite end extending from said hollow sections.

8. A ski as defined in claim 6, wherein said body is formed of ultra high molecular weight polyethylene.

9. A ski as defined in claim 6, comprising second fixation holes in a bottom face of said recessed area for fixing a wear bar to said bottom wall of said body.

10. A ski as defined in claim 9, wherein said bottom wall has a central longitudinally extending projection; said projection displaying an elongated concavity to receive therein said wear bar defining opposite steering surfaces.

11. A ski used for the steering of a snowmobile comprising: an elongated one-piece blow molded body formed of polyethylene; said body having a top wall and a bottom wall; said top wall having raised portions defining hollow sections with said bottom wall; said raised portions displaying a central area adapted to receive the lower end of a snowmobile steering component; said defining opposite lateral sides; and first fixation hole means in said lateral sides for fixing said steering component to said ski.

12. A ski used for the steering of a snowmobile, said ski comprising: a one piece blow molded body formed of polyethylene; said body having a top wall and a bottom wall integrally molded together; said top wall being formed of raised portions with respect to the bottom wall thereby defining hollow sections between the top and bottom walls; said top wall including a central recessed area adapted to receive therein a suspension plate forming part of a steering component of the snowmobile; said recessed area defining opposite sides, each side having a corresponding bolt hole for receiving a bolt to secure the steering component to the ski; said hollow sections including a front hollow section located forward of the central recessed area, a rear hollow section located rearward of the central recessed area, a first side hollow section located on one side of the central recessed area, and a second side hollow section located on the opposite side of the central recessed area.

13. A ski as defined in claim 12, wherein the bottom wall further comprises an elongated, narrow concave surface for receiving therein a correspondingly elongated, narrow metallic wear bar.

14. A ski as defined in claim 13, wherein said elongated narrow concave surface on the bottom wall further comprises a first bottom

recessed portion and a second bottom recessed portion for receiving therein first and second ends of the elongated, narrow metallic wear bar, respectively.

15. A ski as defined in claim 12, further comprising a plurality of bottom bolt holes in the elongated narrow concave surface, said bottom bolt holes extending through the top and bottom walls of the ski for receiving therein corresponding threaded projections on the wear bar for securing the wear bar to the ski.

16. A ski as defined in claim 12, further comprising a handle, said handle including a forward area integrally molded to a front edge of the ski, and a rearward area integrally molded to the portion of the top wall defining the forward hollow section.

17. A ski as defined in claim 12, wherein the body is formed of ultra high molecular weight polyethylene.

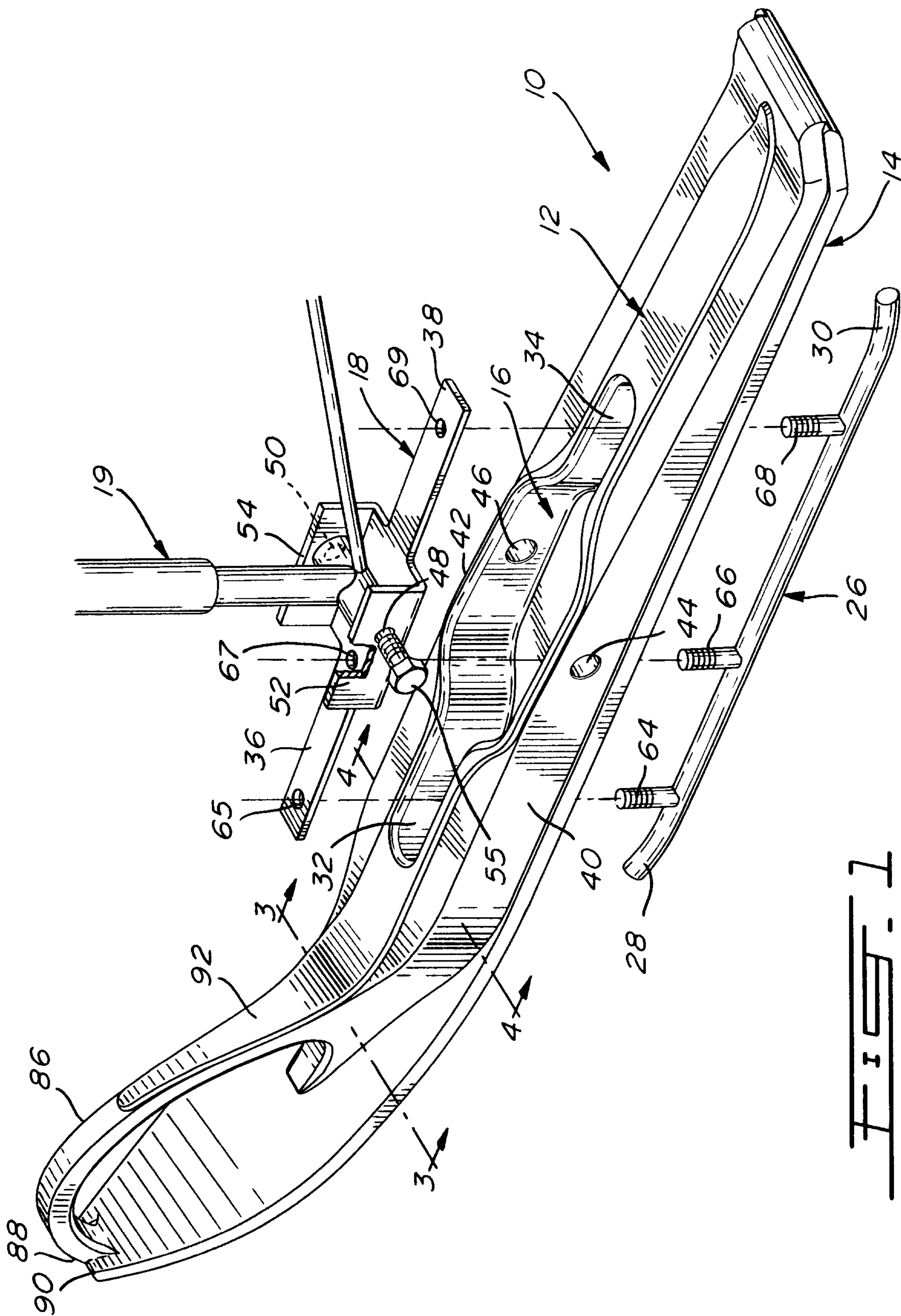

FIG. 1

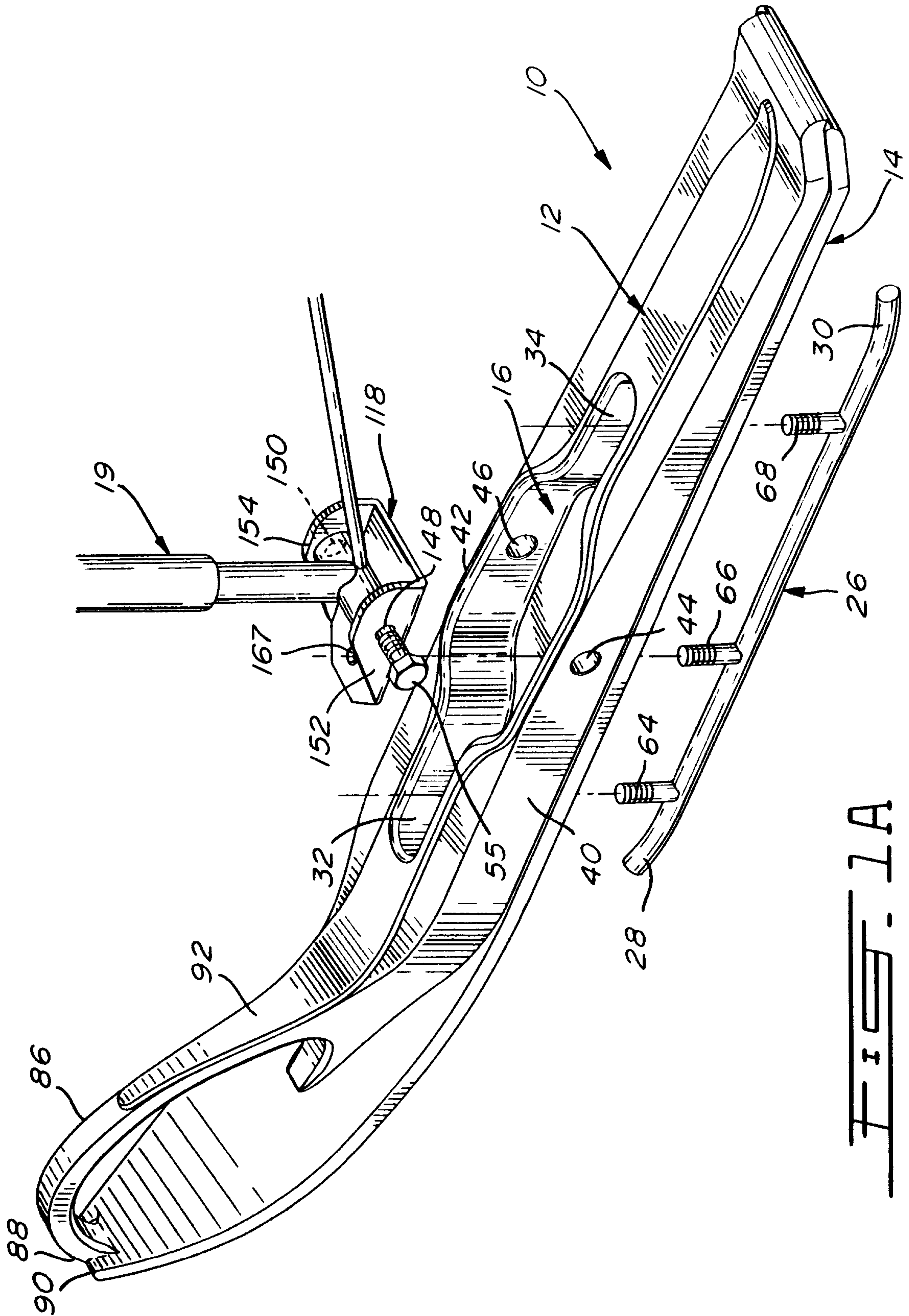

FIG. 1A

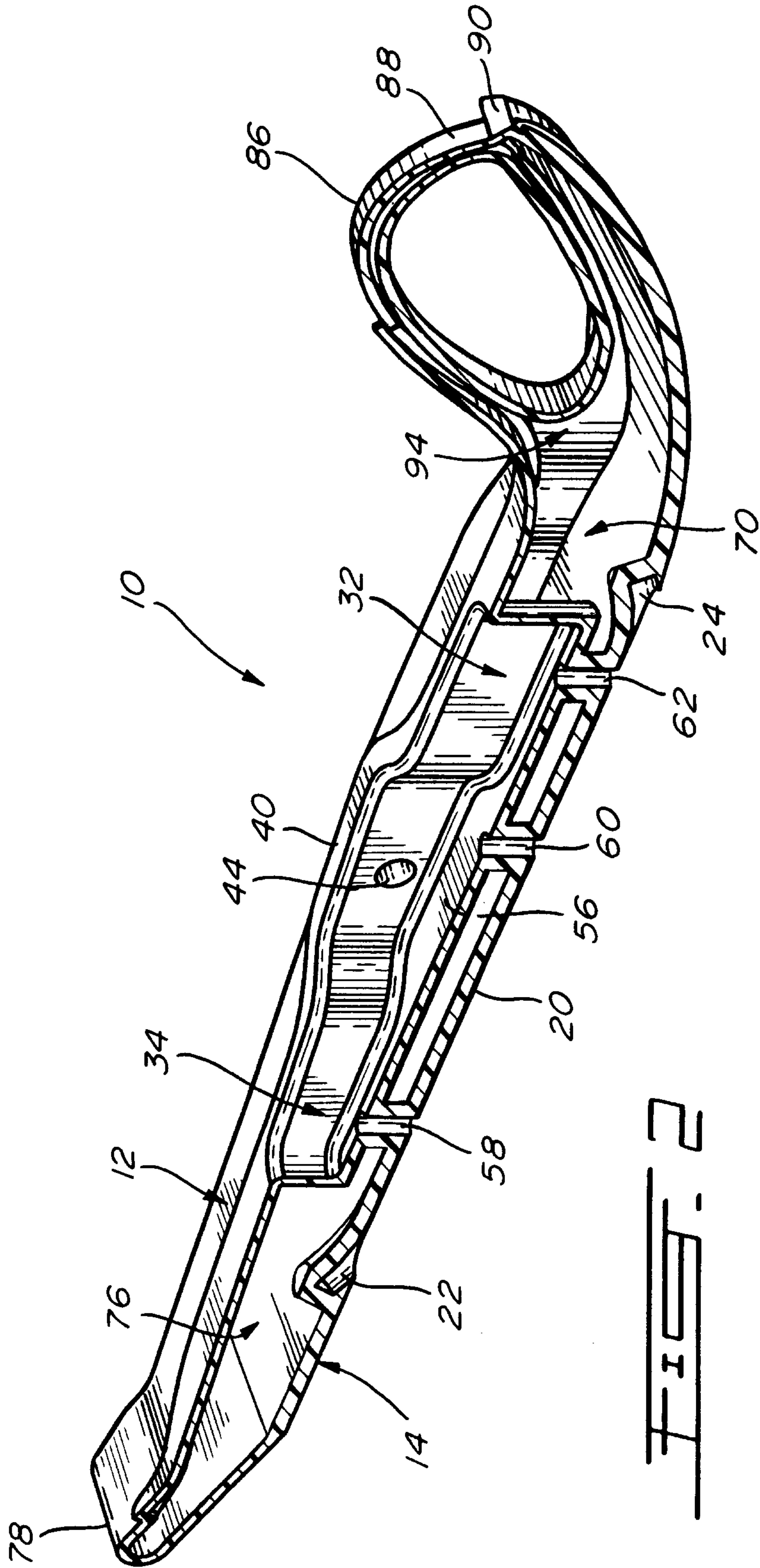

FIG. 2

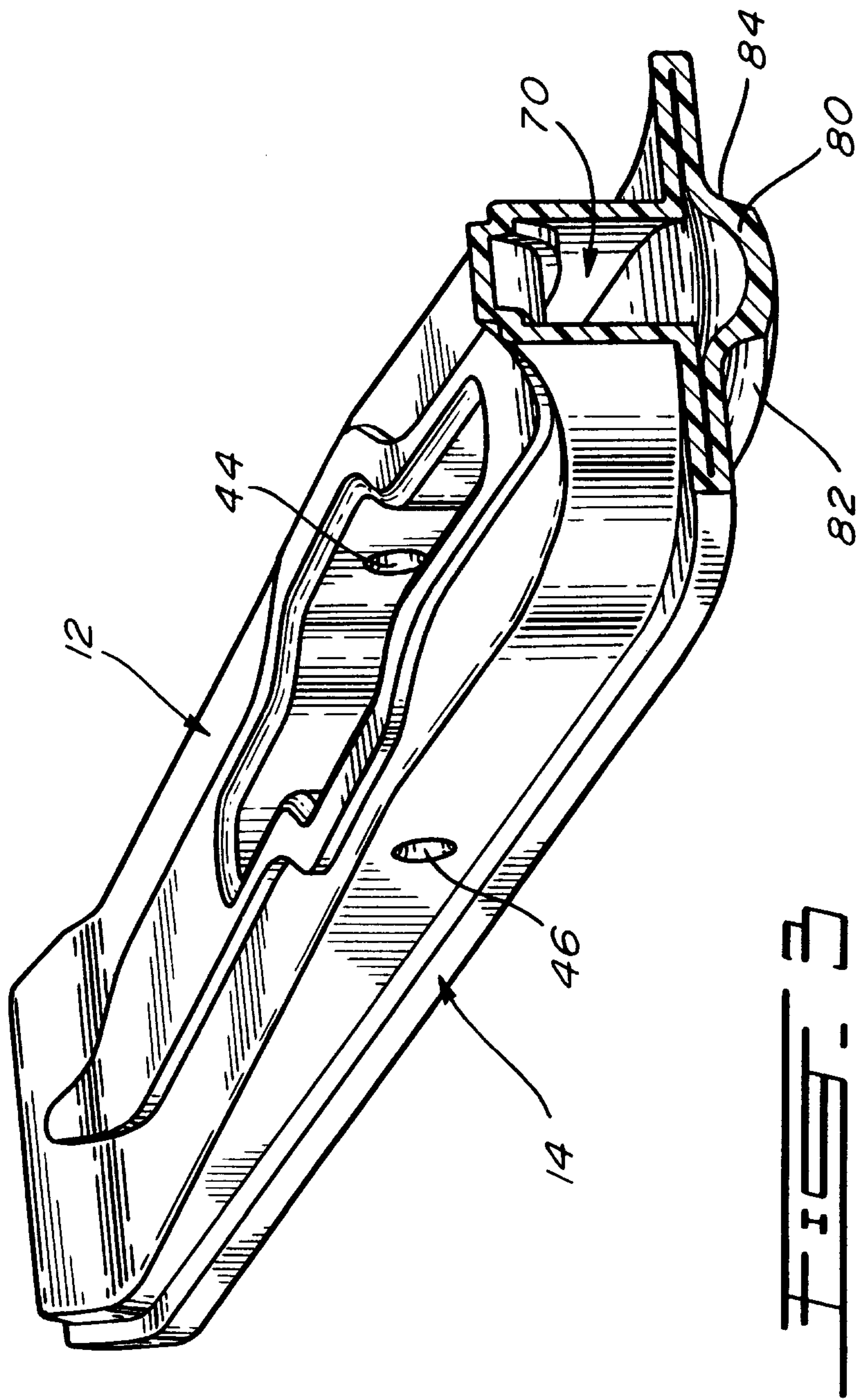

FIG. 3

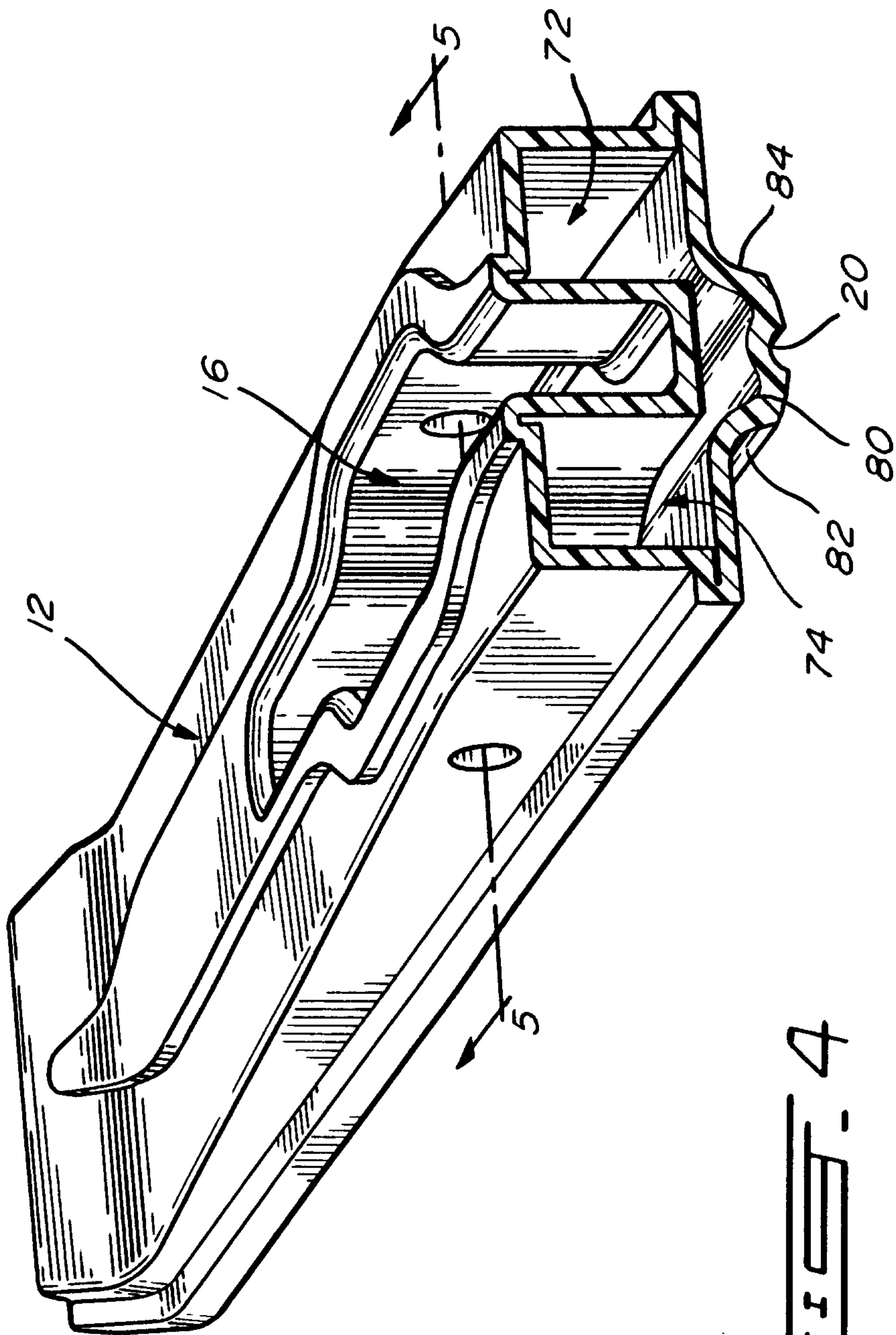

FIG. 4

2195166

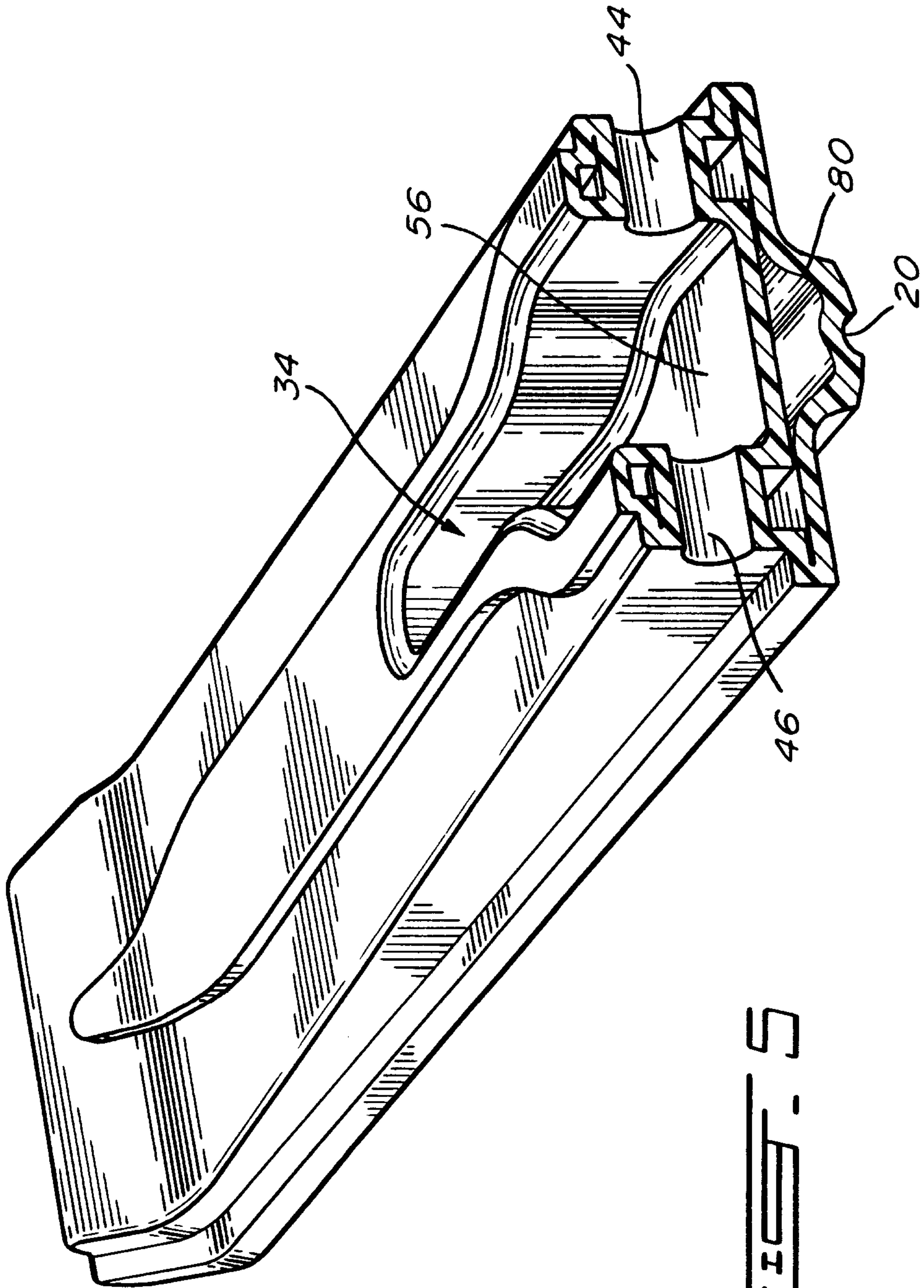

FIG. 5

