

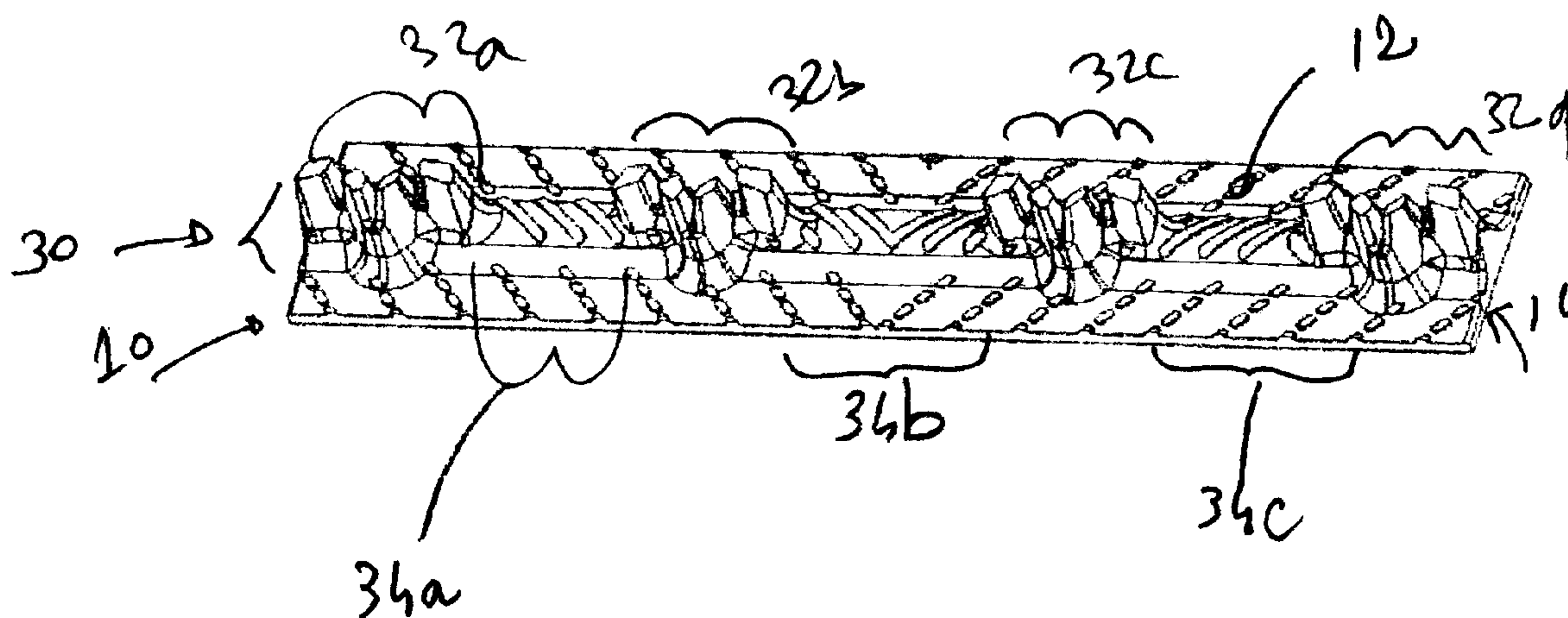

(22) Date de dépôt/Filing Date: 2004/01/16
(41) Mise à la disp. pub./Open to Public Insp.: 2005/07/16

(51) Cl.Int.⁷/Int.Cl.⁷ B62D 55/18
(71) Demandeur/Applicant:
CAMOPLAST INC., CA
(72) Inventeur/Inventor:
DANDURAND, JULES, CA
(74) Agent: GOUDREAU GAGE DUBUC

(54) Titre : CHENILLE A TRACTION PUISSANTE
(54) Title: HIGH TRACTION TRACK



(57) Abrégé/Abstract:

A snowmobile drive track including an endless body having a ground engaging outer side provided with traction lugs, wherein the traction lugs display an angled outer edge for an increased penetration into the ground and a reduced production of noise.

ABSTRACT OF THE DISCLOSURE

A snowmobile drive track including an endless body having a ground engaging outer side provided with traction lugs, wherein the traction lugs display an angled outer edge for an increased penetration into the ground and a reduced production of noise.

TITLE OF THE INVENTION

High traction track

FIELD OF THE INVENTION

[0001] The present invention relates to a snowmobile drive track. More specifically, the present invention is concerned with a high traction track for snowmobiles.

BACKGROUND OF THE INVENTION

[0002] Snowmobile tracks or tracked recreational vehicles and ATV tracks are formed of an assembly of a molded rubber base having, embedded therein, one or more layers or reinforcing fabric and a series of bars that extend crosswise of the track in central and lateral portions thereof. These crossbar portions display a series of raised profiles, each defining a ground engaging projection or traction lug which provides traction and control to the track.

[0003] Efforts have been made to provide traction lugs allowing an increased traction of the track, and also to decrease the noise they generate at certain rotational speeds of the endless track.

[0004] There is still a need in the art for high traction tracks.

BRIEF DESCRIPTION OF THE DRAWINGS

[0005] In the appended drawings:

[0006] Figure 1 is a perspective view of a portion of a track in accordance with the present invention;

[0007] Figure 2 is side view of the track of Figure 1; and

[0008] Figure 3 is a side view of a column of a lug of the track of Figure 1.

DESCRIPTION OF EMBODIMENTS OF THE INVENTION

[0009] Referring to Figures 1 and 2, there is shown, in part, an endless track, generally denoted 10, for propelling a snowmobile over snow, ice, or other similar ground structure. The mounting of this track to a snowmobile is well known and needs not be detailed. The track has a ground engaging outer side 12 and an inner side 14 that receives and supports, on a lower run thereof, a suspension which may consist of a wheel assembly or a slide rail assembly, both of which are also well known in the art.

[0010] The track 10 defines a plurality of crossbar receiving areas 30 that extend through a central, a lateral and a suspension bearing portions of the track. Such a crossbar receiving areas 30 displays an arrangement of profile regions 32 and profile-free regions 34. Such an arrangement of profiles and profile-free regions defines a tread pattern, which may be repeated on successive crossbar receiving areas.

[0011] The profile regions 32a-32d bear outward extending traction lugs, which are made of a series of columns for example, in the embodiment illustrated herein.

[0012] Each lug 40, or each column thereof, features a multi-angle outward edge 44, as may be seen in Figure 3, instead of a flat surface. The orientation of each lug 40 or column may be randomly selected, not only longitudinally with respect to a base line 46 of the side 12, but also transversally thereto.

[0013] People in the art will appreciate that such a configuration allows for the contact between the track and the ground to be driven upon to occur gradually, as each angled mini surface of a lug comes to grip therewith, thereby allowing an increased traction through an increased penetration in the ground, such as snow.

[0014] Moreover, it is found that this configuration results in a reduced production of noise, due the contact between the track and the ground occurring gradually.

[0015] Although the present invention has been described hereinabove by way of embodiments thereof, it can be modified, without departing from the nature and teachings of the subject invention as described herein.

4

CLAIMS

1. A high traction track as described herein.

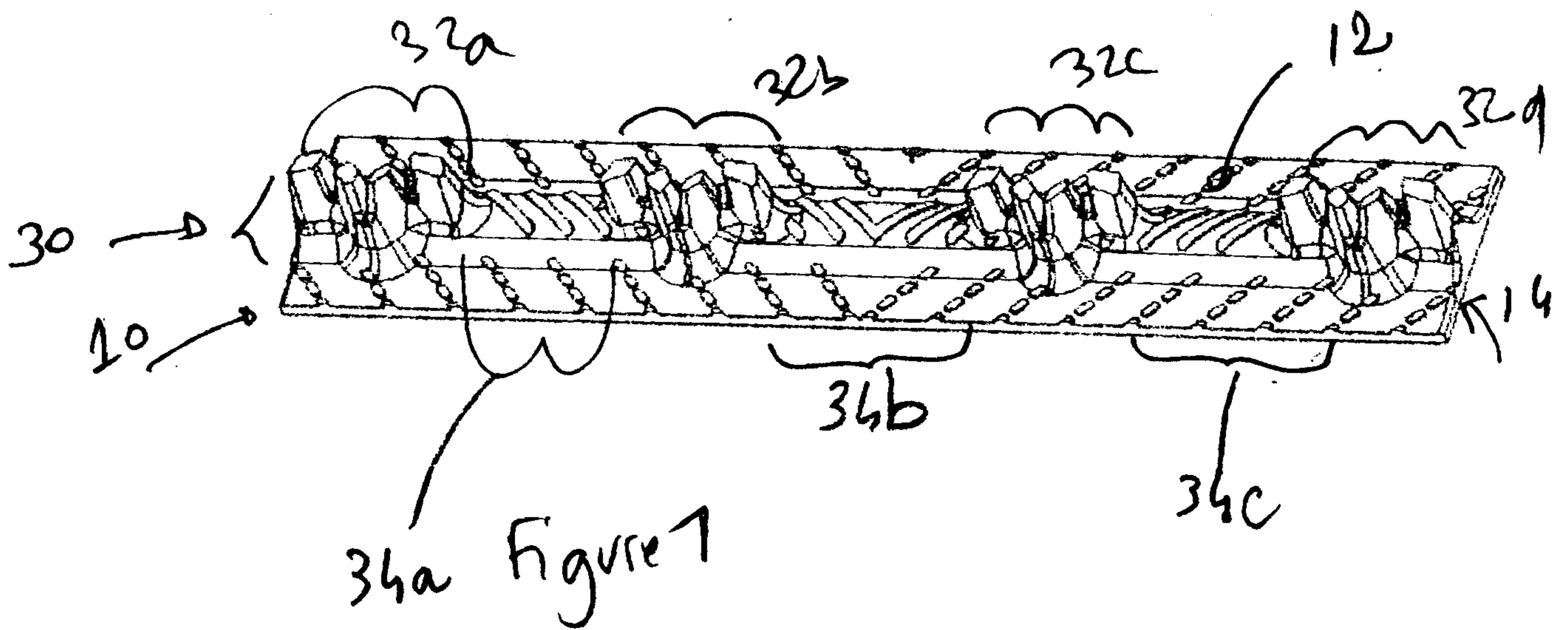

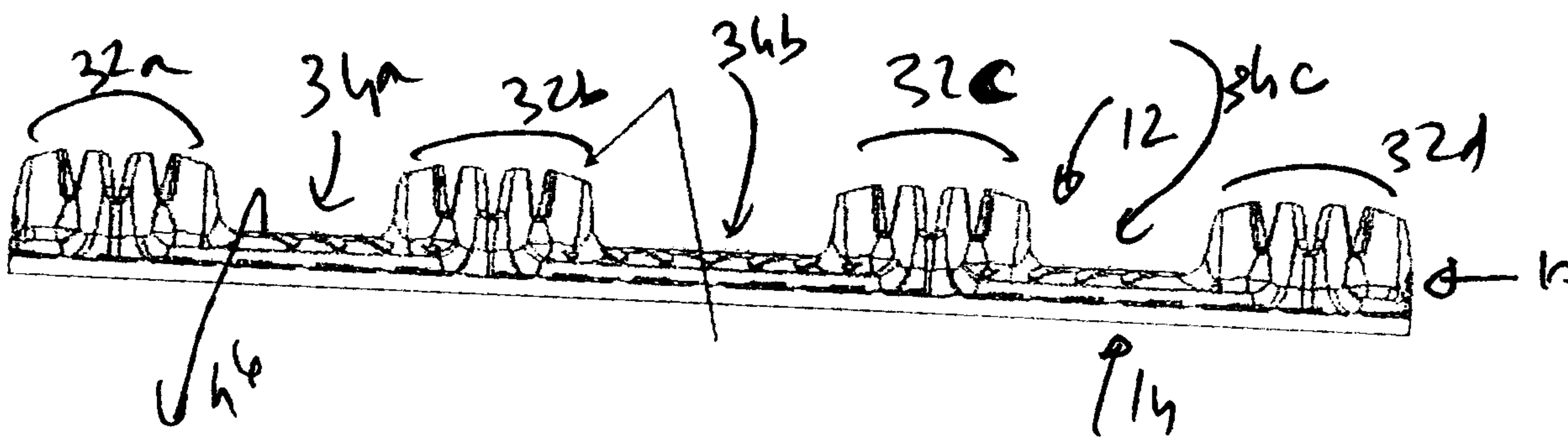

Figure 2

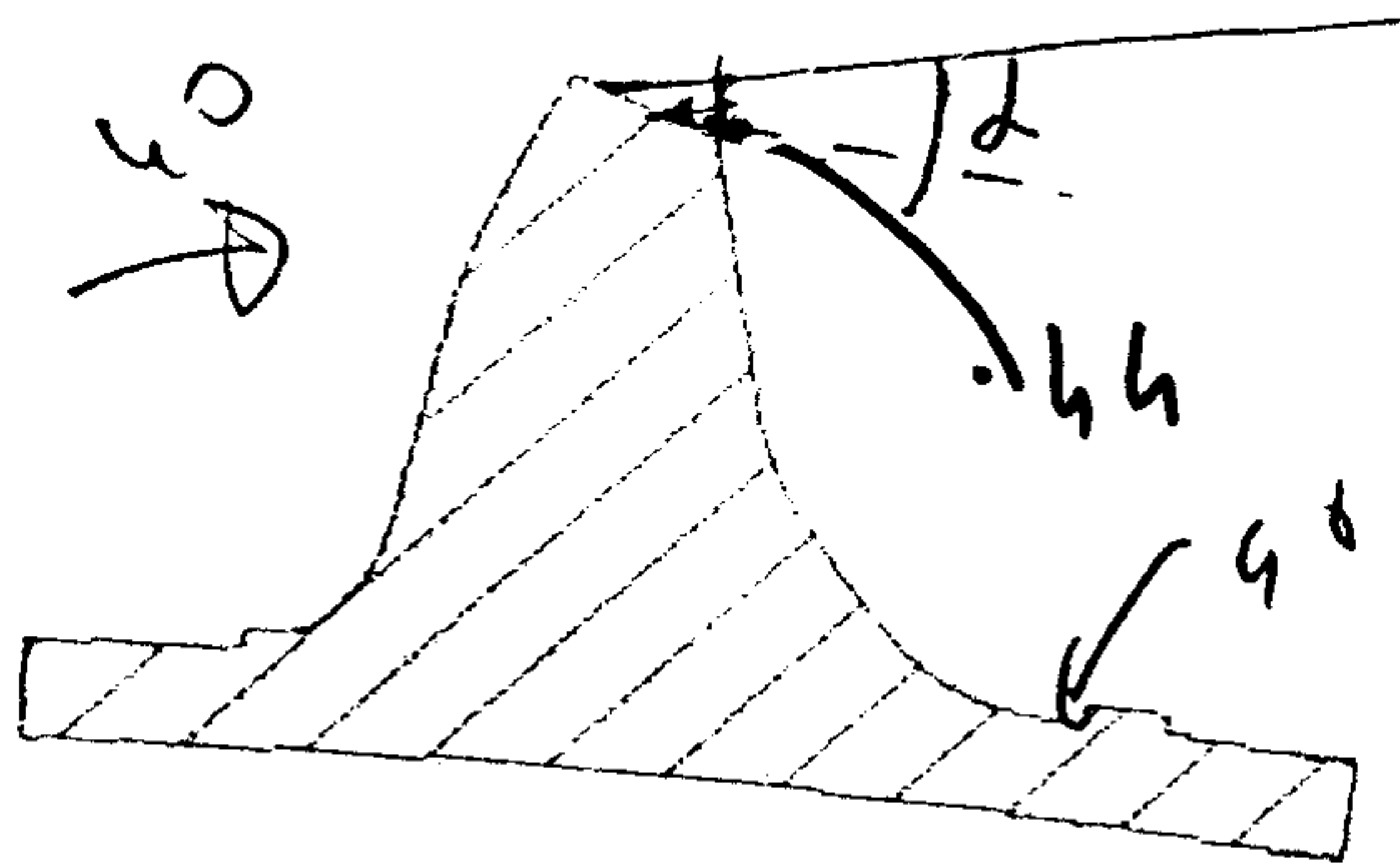

figure 3

