

(19)



(11)

EP 4 429 934 B1

(12)

EUROPEAN PATENT SPECIFICATION

(45) Date of publication and mention of the grant of the patent:
15.10.2025 Bulletin 2025/42

(51) International Patent Classification (IPC):
B62B 17/04 (2006.01) B62B 13/06 (2006.01)

(21) Application number: **22813628.9**

(52) Cooperative Patent Classification (CPC):
B62B 13/06; B62B 17/04

(22) Date of filing: **04.11.2022**

(86) International application number:
PCT/FI2022/050727

(87) International publication number:
WO 2023/079215 (11.05.2023 Gazette 2023/19)

(54) **FRONT SUSPENSION FOR AN ELECTRIC SNOWMOBILE**

VORDERRADAUFHÄNGUNG FÜR EIN ELEKTRISCHES SCHNEEMOBIL

SUSPENSION AVANT POUR MOTONEIGE ÉLECTRIQUE

(84) Designated Contracting States:
AL AT BE BG CH CY CZ DE DK EE ES FI FR GB GR HR HU IE IS IT LI LT LU LV MC ME MK MT NL NO PL PT RO RS SE SI SK SM TR

- **AUTIONIEMI, Matti**
96100 Rovaniemi (FI)
- **NISKANEN, Jori-Jaakko**
96190 Rovaniemi (FI)

(30) Priority: **08.11.2021 FI 20216150**

(74) Representative: **Berggren Oy**
P.O. Box 16
Eteläinen Rautatiekatu 10A
00101 Helsinki (FI)

(43) Date of publication of application:
18.09.2024 Bulletin 2024/38

(73) Proprietor: **Aurora Powertrains Oy**
96100 Rovaniemi (FI)

(56) References cited:
EP-A1- 1 798 081 US-A- 5 503 242
US-A1- 2017 305 500 US-B1- 9 327 789

(72) Inventors:
• **HAAVIKKO, Olli**
97220 Sinettä (FI)

EP 4 429 934 B1

Note: Within nine months of the publication of the mention of the grant of the European patent in the European Patent Bulletin, any person may give notice to the European Patent Office of opposition to that patent, in accordance with the Implementing Regulations. Notice of opposition shall not be deemed to have been filed until the opposition fee has been paid. (Art. 99(1) European Patent Convention).

Description

Technical field

[0001] The present invention relates to snowmobiles and especially electrically driven snowmobiles. In more detail, the present invention relates to front suspension structures of the electrically driven snowmobiles.

Background

[0002] A snowmobile is a vehicle for winter transport even in rural forest-dominating terrains and also for recreational activities when there is enough snow present for the vehicle. Traditionally snowmobiles have been using internal combustion engines as their power source, which makes sure that the travelling range is long enough even in rural and remote areas. This is also a safety matter.

[0003] Snowmobiles have a rather large rolling resistance, which correlates strongly to their relatively large consumption of power. Therefore, traditional snowmobiles with internal combustion engines have consumed rather large amount of fuel / 100 km. This becomes a safety issue in the wilderness, as there thus emerges a need for larger fuel tanks (or well-planned locations for refueling), which would further affect the drivability through excess weight on the vehicle. Thus, there has been some research to get rid of the power systems revolving around internal combustion engines; also because of the environmental reasons and trends.

[0004] Electrically driven snowmobiles have already been presented, e.g. in patent application publication FI 20175471, but the concept is pretty new and applied quite marginally currently in the snowmobile industry. However, the interest towards designing environmentally friendly and also quieter options for transport in the wilderness has been large, and in the future, these aspects most likely will become even more relevant for the customers and manufacturers.

[0005] The snowmobile is constructed around and within a specifically designed frame. Such a frame has many practical requirements, such as robustness, endurance against (almost continuous) shocks and impacts, and endurance also in winter conditions. Still, a certain lightness is good in order to have good maneuverability for the driver, and on the other hand, the location or height of the driver (i.e. the driver seat height) affects this as well, and also the centre of gravity is usually desired to be locating in a quite low position.

[0006] A prior art snowmobile from the early 2000's involves a profile-structured upper part of the frame, a so-called "pyramid structure", which also enables a stiffer solution compared to the earlier ones. The pyramid structure comprises a first A-shaped element giving support towards/from the front part of the frame, a second A-shaped element giving support towards/from the middle part of the frame, and a third A-shaped element giving

support towards/from the rear part of the frame. The shock absorbers of the skis are attached from their upper ends to the lower part of the front-most A-shaped element. The impulse-typed forces hitting the skis and propagating towards and along the shock absorbers, will transfer via the front-most A-shaped element towards the top of the pyramid structure. From there, the forces will distribute via the central and rear A-shaped elements to the lower part of the frame.

[0007] As FI 20175471 discloses, the drive system of a new electric snowmobile or a converted electric snowmobile (from the one applying internal combustion engine) may comprise a primary driving axis, a gear mechanism, a drive axle, and an endless drive track rotating in contact with the snow below. The reference comprises an electric motor, which is placed within the frame, where the connection of the motor can be made via a connecting adapter. The connecting adapter comprises intrinsic flow channels designed for a cooling air or liquid, in order to direct excessive heat away from the electric motor.

[0008] US 2008/0173491 ("Fecteau") discloses a front suspension for a snowmobile. This is a double A-arm structure, comprising an upper A-arm, a lower A-arm and a spindle connecting these two A-arms to the respective ski. The connection of these A-arms to the spindle defines a caster angle. The upper and lower A-arms are connected to a front portion of a frame so that the caster angle will decrease when the front suspension is compressed during driving in rough terrain. Fecteau's suspension travel distance vertically is defined to be preferably approximately between 20 ... 30 cm (between 8 ... 12 inches). Fecteau is all about an internal combustion engine driven snowmobile, and there are no mentions whatsoever towards electric motors or battery compartments as the snowmobile's power source.

[0009] CA 2478003 ("Väisänen") discloses a front suspension for a snowmobile as well. This structure comprises a lower A-arm assembly and an upper suspension arm for connecting each front ski to the chassis of the snowmobile. The purpose of the lower A-arm assembly is to restrain the front ski from moving backward or in a lateral direction. The upper suspension arm is designed to connect to the top of a spindle which ensures that the spindle (i.e. element 34) will remain substantially vertical when the front ski encounters a bump. A shock absorber assembly (i.e. element 26) comprises a spring structure and it is aligned in a slightly tilted angle from the vertical direction as Figure 6 in a top plan view illustrates. Väisänen is all about an internal combustion engine driven snowmobile (see par. [0003], line 3), and there are no mentions whatsoever towards electric motors or battery compartments as the snowmobile's power source.

[0010] EP 1798081 ("Tonoli") discloses a vehicle with tilting suspension system. This tilting action happens when the surface underneath the skis are on a different level or if the surface plane is not exactly horizontal. Shock absorbers are also part of the structure of the vehicle. Four A-arms connect the skis to the rest of the

frame.

[0011] US 9,327,789 ("Vezina") discloses a leaning vehicle, which has very good leaning properties as Fig. 22 illustrates. The arms connecting the skis to the other parts of the frame are not all straight rods. Furthermore, the upper connection points ("340") of the two shock absorbers onto the frame are not the same as Fig. 20 for instance shows.

[0012] US 5,503,242 ("Jeffers") discloses a propeller driven snow buggy. Rather narrowly shaped A-arms are used, and their central axes for all four A-arms (14, 16) are parallel. The connection point of each rod of the A-arms to the frame is on the side edge of the vehicle. There is no endless belt, or a roller tunnel, as this vehicle works with propels.

[0013] US 2017/0305500 ("Vigen") discloses a spindle and suspension system for recreational vehicles, such as snowmobiles. The structure connecting the skis to the rest of the frame is made of rods which mostly have parallelly directed sections. The front section of each ski forms a loop-shaped design. Shock absorbers and the endless belt are part of the concept in a rather traditional fashion. The scope focuses especially on the spindle and the suspension system but also on the whole vehicle.

[0014] The prior art has several problems relating to front shock absorbers and their connecting points within the frame. As the prior art involves internal combustion engines, and additional parts required because of that technique, there are more restrictions in the freedom of the design for the snowmobiles. This means less available space, or otherwise the aerodynamical properties would suffer. This space-related deficiency is present currently by looking at the available distance for the shock absorbers e.g. in Fig. 7 of Väisänen. Because the main front body of the chassis reaches to the very front (see Figures 1 and 4 of Väisänen; also Fig. 1 of Fecteau), there is a rather small distance available vertically for the front shock absorbers. Therefore, the effective length of the shock absorber during maximum compression is rather short in prior art.

[0015] Also in prior art applying an internal combustion engine, the lower A-support rod and its more rear connection point to the frame, needs to be connected quite in front because the front part of the chassis is filled with parts and technique required there. Therefore, the currently placed rear connection points of the lower A-support rods are not optimal, when concerning strength or endurance optimisation of the frame structure concerning electric snowmobiles. The connection points locate usually 15-25 cm in front of the location where the front end of the roller tunnel (i.e. involving the endless drive track) locates, when looking the situation from the top side. This location of the rear connection points for the lower A-shaped rods results in a snowmobile frame which would be less resistant to all types of possible external forces, and it would even result in a snowmobile, whose frame would not tolerate certain external forces and

impulses during longer usage periods as well as it should, or as well as it is expected in this field. Thus, this design characteristic is intolerable in electric snowmobiles, if nothing is done to the earlier design.

[0016] Because of the restrictions for the lower A-support rods i.e. for the lower suspension A-arms, the prior art design involves different geometries between the upper and the lower suspension A-arms. This is not optimal for proper shock absorbance properties of the snowmobile.

[0017] In other words, the forces directed to the frame and chassis are relatively large, if the so-called spindle or the spindle arm (like the vertical element 34 of Väisänen; or element 110 in Fecteau) is relatively short, as is the case in Fecteau and Väisänen, and also in the rest of the traditional snowmobile solutions. And when staying within the internal combustion engines based solutions, the redesign is extremely hard. Besides the engine itself, there are also various gas exchange systems (pipes and sound reduction arrangements, for instance), and the variable ratio transmission system, which are rather large in their size, and they thus create notable restrictions when trying to redesign the frame structure and the shock absorbers of the traditional snowmobile. There are also protective metal and plastic structures around the variable ratio transmission system and around the gas exchange systems, which take their own space. An electric snowmobile is free from these volumetric constraints.

[0018] Currently, there has not been presented an efficient, suitable and advantageous design involving shock absorbers, which would have been designed and optimized especially for electrically driven snowmobiles. This is the main problem in the prior art.

35 Summary

[0019] The present invention is defined in claim 1 and introduces an electric snowmobile (1) with efficient shock absorbance properties, wherein the electric snowmobile (1) comprises a frame (9), comprising a front part (8) of the frame, which front part (8) of the frame comprises two upper suspension A-arms (5) and two lower suspension A-arms (6). Preferred embodiments are defined in the dependent claims.

[0020] In the electric snowmobile (1) the upper and the lower suspension A-arms (5, 6) locate substantially on top of one another with a mutual distance, with mutually parallel mirroring angles of the A-arms (5, 6), for each pair of upper and lower suspension A-arms (5, 6) for each of the skis, and the electric snowmobile (1) further comprising front shock absorbers (4), whose top connection points locate at the same location essentially on a top of an essentially pyramid-shaped structure of the front part (8) of the frame (9).

[0021] In an embodiment of the present invention, the front part (8) of the frame (9) comprises a spindle (7) per each ski, which spindle (7) is a relatively long vertical element connected to each of the skis, and where the

upper and lower suspension A-arms (5, 6) are fixed to the spindle (7) in their top location of the A-shapes.

[0022] In an embodiment of the present invention,

- the upper left suspension A-arm (5) is fixed to the top of the left spindle (7), the lower left suspension A-arm (6) is fixed to the left spindle (7) so that the mutual distance is larger than the distance from the lower left suspension A-arm's (6) fixation point to a bottom surface of the left ski, and
- the upper right suspension A-arm (5) is fixed to the top of the right spindle (7), the lower right suspension A-arm (6) is fixed to the right spindle (7) so that the mutual distance is larger than the distance from the lower right suspension A-arm's (6) fixation point to a bottom surface of the right ski.

[0023] As defined in claim 1, a rear connection point (13) for the lower suspension A-arm (6) in both the left and right sides locates at or right next to the longitudinal side edge (12) of the roller tunnel, and further, the rear connection point (13) for the lower suspension A-arm (6) in both the left and right sides locates at or close to the lateral vertical plane along the front end (11) of the roller tunnel.

[0024] In an embodiment of the present invention, the frame (9) is configured so that:

- determining four end points including the two outer ends in each of the upper and lower suspension A-arms (5, 6) in the left side of the snowmobile (1),
- designing the locations of the four end points so that they define together corners of a rectangle,
- determining further four end points including the two outer ends in each of the upper and lower suspension A-arms (5, 6) in the right side of the snowmobile (1),
- designing the locations of the further four end points so that they define together corners of another rectangle.

[0025] In an embodiment of the present invention, the snowmobile (1) is configured to obtain a constant or essentially constant camber angle (α) in relation to a vertically locating plane (s) across the whole compression or movement range of the front shock absorbers (4), where the plane (s) locates along the longitudinal central line of the snowmobile (1).

[0026] In an embodiment of the present invention, the snowmobile (1) is configured to obtain a constant or essentially constant caster angle (β) in relation to a lateral vertical plane (r) across the whole compression or movement range of the front shock absorbers (4), where the plane (r) locates across the area of the snowmobile (1) where the skis locate.

[0027] In an embodiment of the present invention, the electric snowmobile (1) comprises:

- an encapsulating body (2), comprising a part having a hexahedronally shaped inner surface;
- a driver's seat (3) directly installed on top of a central horizontal part of the encapsulating body (2);
- a battery package in the hexahedronally shaped space defined by the part of the encapsulating body (2); and
- one or more vibration isolators (10) configured between the battery package and the encapsulating body (2), for diminishing the effects from outer shocks towards the battery package.

Brief description of the drawings

15 **[0028]**

Figure 1 illustrates an electric snowmobile with a multifunctional frame structure according to an embodiment of the present invention,

20

Figure 2 illustrates the encapsulating body and vibration isolators in more detail,

25

Figure 3 illustrates a front part of the frame of the multifunctional frame structure in more detail,

30

Figure 4 illustrates a front part of the frame of the multifunctional frame structure also in more detail, highlighting various elements of the front part,

35

Figure 5 illustrates certain dimensional features concerning the front end of the roller tunnel and the rear connection point for the lower suspension A-arm, in the present invention,

40

Figure 6 illustrates a direct side view from the electric snowmobile, in an embodiment of the present invention,

45

Figure 7 illustrates the compression action made possible by the front shock absorbers, as a front view of the electric snowmobile, and

Figure 8 illustrates the compression action made possible by the front shock absorbers, as a side view of the electric snowmobile.

Detailed description

50

[0029] The present invention presents a front suspension structure especially suitable for electric snowmobiles. By this we mean physical parts and their mutual connections and design features within the electric snowmobile which relate to mitigating effects of shocks and bumps.

55

[0030] When concerning the electric power transmission and different physical parts and functional entities within a snowmobile, a main problem is the small avail-

able space i.e. volume. With internal combustion engines driven snowmobiles, there have been strong restrictions in designing and placing different parts and connection points within the frame in an appropriate manner. For instance, this has led to the front shock absorbing characteristics being not optimal. And for electrically driven snowmobiles, the redesigning work has not really taken place, at least not until now. The present invention redesigns some parts of the electric snowmobile by benefiting from some free space, which is now vacated from some internal combustion engine-based technical parts. Many advantages are made possible with the redesigned solution; see them later.

[0031] One main characteristic and trend in this century for the snowmobiles is that created snowmobile designs have enabled the user, i.e. the driver, to sit on the snowmobile like on a motorbike. This is thus more convenient for the driver also during longer rides, as it brings clear improvements in riding ergonomics. This "better-posture" feature was presented for the snowmobiles in the early 2000s. Such a design is now the prevailing solution across various different manufacturers of snowmobiles.

[0032] The main purpose in the present invention is to design an electric snowmobile, which has excellent front shock absorbers, and which thus mitigates external bumps and shocks very efficiently.

[0033] Next we discuss the main features and details of the present invention by referring to embodiments shown in Figures 1-8, and going through them one by one.

[0034] Figure 1 illustrates an electric snowmobile 1 with a multifunctional frame structure according to an embodiment of the present invention. This drawing illustrates the vehicle as a whole, and in a rather general level.

[0035] The electric snowmobile 1 comprises an encapsulating body 2 which is a longitudinally placed element. The encapsulating body 2 may also be considered as a cover-like element protecting the electric elements and parts and also power transmission parts within the electric snowmobile 1. Furthermore, the encapsulating body 2 may be made from a metal sheet, which is shaped through folded and twisted parts so that the encapsulating body 2 forms a certain volumetric area meant for the battery package and for other elements such as power transmission elements and other electrical parts, e.g. connecting cabling. In an embodiment, not all the required elements need to locate within the volume defined by the encapsulating body 2, but for instance the battery package and the electric motor may locate within the volume defined by the outer surface of the encapsulating body 2. The encapsulating body 2 may be open from below so that the encapsulating body 2 comprises a "roof-part" and "side-walls-part", bent and formed from a planar metal sheet and possibly with connecting rods or protrusions, to form a structure which may be placed on top of the battery package. Simultaneously, the top surface of the encapsulating body 2 may form a platform, base or surface for the driver's seat 3 to be installed. The driver's

seat 3 may comprise foamed plastic, set and attached between a top layer of leather and the top surface of the central part of the encapsulating body 2. Thus, the encapsulating body 2 forms a direct base for the seat 3 of the driver.

[0036] The encapsulating body 2 may be manufactured from metal, or from some hard but lighter material which has good endurance against impulse-type of forces and twisting forces, in an embodiment. In another possible embodiment, the encapsulating body 2 is manufactured from metal, or as a composite structure involving metals and/or plastic, or from material capable to bear the forces directed towards the frame 9 and the encapsulating body 2. The encapsulating body 2 may be manufactured as a singular element, or from several separate parts which are attachable together in some way. The snowmobile 1 is prone to experience sudden and also possibly rather large forces, which usually have a force vector having mainly a vertical element, such as when the snowmobile 1 experiences a bump when riding onto an edge of the pothole on the terrain. However, the forces may also have a major horizontal component, when the snowmobile 1 hits a tilted edge of a pothole directing the snowmobile instantly more to left or to right, or when simply the driving action of the user makes a sharp turn for the snowmobile 1. In these varyingly directed external forces, the encapsulating body 2 needs to maintain all the internal elements such as the battery package well in its place, no matter the "quality" of the terrain where the driving takes place. Elastic elements or otherwise vibration-suppressing elements can be placed between the lower surface or the inner side surface of the encapsulating body 2 and the battery package right under or adjacent to it. Thus, the contact between the battery package and the inner surface of the encapsulating body 2 can be made sufficiently good and lasting, no matter the impulse-type of forces present during the driving. Also, any impulse experienced by the elastic or vibration suppressing elements will greatly be absorbed in these intermediate softening elements, reducing strain experienced on the outer walls and surfaces of the battery modules within the battery package.

[0037] Comparing to the prior art, the encapsulating body 2 now acts as a support structure which fully replaces the profile-structured pyramid solution with three A-shaped elements (as in prior art). The functions and characteristics enabled by the encapsulating body 2 fully replace the characteristics made possible by the pyramid-solution, and furthermore, the present invention provides an optimized solution for electrically driven snowmobiles, concerning volumetric consumption within the snowmobile's outer housing by different functional entities and structural features. Also in case of constant bumps and impulses experienced by the electric snowmobile 1 during normal driving, the invented structure involving the encapsulating body 2 is well suited to absorb and direct the forces so that the inner parts, such as the battery package, are not physically harmed, or e.g.

electrically disconnected, during driving in the harsh conditions. The use of the encapsulating body 2 thus provides advantages over the profile-structured prior art solution.

[0038] As an alternative or added functional element concerning shock reductions, there may be specific vibration isolators 10 between the battery package and the frame 9 but these are discussed later in connection with Figure 2. There may be one or more (e.g. three) vibration isolators 10 installed in the snowmobile 1, for diminishing the effects of vibration onto the battery package. In case of three vibration isolators, the electric snowmobile 1 comprises three locations between the battery package and the frame 9 where the vibration isolators 10 have been placed, for enabling twisting forces onto the frame 9 without creating twisting forces towards the battery package.

[0039] Below the encapsulating body 2, there is an endless drive track, which functions as "a driving mat" and as a direct interface between the vehicle itself and the snow surface on the terrain. The power from the electric motor is converted to a rotating movement of the endless drive track.

[0040] In the front side of the frame, there are two steerable front skis, which are connected to the front right and front left side of the frame structure. The steering given by the driver via the handle bar of the electric snowmobile transfers to the turning movement of the front skis.

[0041] As this is an electric snowmobile, there is no need for any internal combustion engine, or any other part which the internal combustion engine specifically requires. As a main advantage and as a major "green" result, there is no exhaust pipe and thus no harmful emissions to the environment, nor any loud motor sounds created by the internal combustion engine. These aspects make the driving experience very pleasant to the driver.

[0042] Figure 2 illustrates the encapsulating body and vibration isolators of the electric snowmobile in more detail, in an embodiment of the present invention. A major part of the frame 9 is visible and shown from the point of view from the top left of the snowmobile structure. The longer element placed in a longitudinal direction which has a horizontally aligned part in the central area, is the encapsulating body 2, which is also visible partly in Figure 1. In this embodiment of the present invention, at least one vibration isolator 10 is placed between the battery package (not shown in Figure 2) and the frame 9, for diminishing the effects of vibration onto the battery package. Furthermore, the electric snowmobile comprises three locations between the battery package and the frame 9 where the vibration isolators 10 have been placed, for enabling twisting forces onto the frame 9 without creating twisting forces towards the battery package. One exemplary location of a vibration isolator 10 is shown in Figure 2.

[0043] Otherwise, concerning the front part 8 of the

frame 9, this embodiment may be implemented similarly as shown in Figure 1 already, and in following Figures 3, 4, 7 and 8. The tail end part of the frame 9 can be designed as shown in Figure 2; this design is also visible in Figure 1.

The illustrated shape however may be varied to some other beneficial shape if desired e.g. for aerodynamical reasons.

[0044] The rest of the elements, especially concerning the front part 8 of the frame 9, are discussed in connection with the following Figures in more detail.

[0045] Figure 3 illustrates a front part 8 of the frame 9 in the multifunctional frame structure of the snowmobile 1 in more detail.

[0046] Figure 3 shows a general structure of the front part 8 of the frame 9, as separated from the rest of the electric vehicle. Front skis make the contact to the snow, and the front skis are connected by mainly vertically aligned rods, i.e. by a left and right spindle 7 to two A-shaped rod structures (i.e. A-arms 5, 6). Two front shock absorbers can be seen as the two thicker rod-shaped elements in a tilted alignment angle near the handle bar in the top of the device. A rear connection point 13 for lower suspension A-arm is marked in Figure 3. This is the element whose location may now be especially changed compared to the prior art solutions (= the internal combustion engine -based snowmobiles). By location, it is especially meant the longitudinal placement of the rear connection point 13 within the frame 9 of the electric snowmobile 1 in view of the front end of the roller tunnel 11; see also Figures 4, 5 and 6 for further views of the arrangement, and concerning some of the referred elements. The rest of the connecting rods (like the ones forming the A-arms 5, 6) and their mutual arrangement within the multifunctional frame structure are explained in connection with Figure 4.

[0047] Figure 4 illustrates the front part of the frame in the multifunctional frame structure of the snowmobile also in more detail, but now highlighting various elements of the front part. Two front shock absorbers 4 can be seen as the two thicker rod-shaped elements in a tilted alignment angle near the handle bar in the top of the vehicle structure. Front skis are the lowermost elements making the contact to the snow, and the front skis are connected by mainly vertically aligned rods, i.e. by a left and right spindle 7 to two A-shaped rod structures (i.e. the lower and upper suspension A-arms 6, 5). The spindle 7 may also be called as a ski leg. The lower suspension A-arms 6 are placed substantially along a horizontal direction. The top point of the A-shape is connected to either the left or right spindle 7 (which locates substantially vertically, sticking up from either the left or right front ski). One branch of the lower left A-shaped element (i.e. half of the respective A-arm 6) is connected to one branch of the lower right A-shaped element (i.e. "mirroring" half of the respective A-arm 6) and the rest of the frame 9, near or at the central longitudinal axis of the vehicle. The connection point can be seen in Fig. 4 as the low central connection point (i.e. a first common connection point),

where five rods depart from nearly the same connection point, in an embodiment. In a further embodiment, there can be five rods connected together directly, or via shaped forms/elements in connection with rods, or via some intermediate connection elements or attachment tools (screws etc.) connecting the lower suspension A-arms 6 firmly to the rest of the frame 9.

[0048] In an embodiment, both branches (of the element 6) starting from the A-shaped top location within either on the left or right spindle 7, will connect to the outer surface of the encapsulating body 2 in the branch's outer end. This can be seen especially in Fig. 1. This connection makes the structure more robust and enduring.

[0049] The top ends of the left and right spindle 7 are where the upper suspension A-arms 5 are connected. The alignment of these A-shaped elements are principally the same as for the lower suspension A-arms 6. Thus, summarizing this structure, in the left hand side there are two A-shaped elements right on top of one another in a similar angular position, and the same applies for the right-hand side as well. Also the upper suspension A-arms 5 will connect together via one of their branches (see Fig. 4), in a second common connection point. Concerning this central axial line in a longitudinal direction of the vehicle, the mutual connection points (i.e. the first and second common connection points) of the lower and upper suspension A-arms 6, 5 will locate along this central axial line, in different heights. As a different physical element, a steering column is connected directly to the handle bar of the electric snowmobile 1.

[0050] There are two front shock absorbers 4 in an embodiment, which are connected in their lower ends to a respective intermediate element, which in turn are connected to a respective upper suspension A-arm 5. Furthermore, the two front shock absorbers 4 are further attached right below the handle bar from their upper ends, where the attachment point near the handle bar locates thus in a vertically higher position than the two intermediate elements. The attachment points of the front shock absorbers 4 are selected so that the alignment of the front shock absorbers 4 forms a tilted and symmetric arrangement, as Fig. 4 illustrates. This structure enables good shock absorption capabilities in case of impulse-like forces and shocks experienced by the electric snowmobile in a bumpy terrain.

[0051] The handle bar in the top of the vehicle thus experiences dampened impulses and mitigated shocks during the driving, and the vertical distance from the handle bar's level of the electric snowmobile to the level of the front skis will oscillate between certain limit values, based on experienced pits and potholes, and other hits created by the surrounding terrain during driving.

[0052] Controlling electric cabling or wirings are not visible in Figure 4.

[0053] The illustrated frame structure creates many advantages. It is light, and enables an improved riding ergonomics for the driver because of the frame's outer

design. It is also robust and enduring during harsh outdoor environments, involving not only bumpy conditions, but also very cold conditions. There is good dampening characteristics for outside forces and impulses, making the driving more pleasurable for the driver. The design offers a driving position, which resembles a driving position made possible by current motorbikes. Also, the space which has been occupied by various parts required in the internal combustion engine -based snowmobiles, are now vacated in the electric snowmobile solution, and this free space is now well used in redesigning some shapes and alignment angles of the various features of the frame structure. Therefore, it can be said that the presented design has been really optimized for the electric snowmobile, and maybe for the first time during the development history of electrically driven snowmobiles.

[0054] Figure 5 illustrates certain dimensional features concerning the front end of the roller tunnel 11 and the rear connection point 13 for the lower suspension A-arm 6, in the present invention. Now it is possible to design the frame 9 and the A-arms 5, 6 so that rear connection point 13 for lower suspension A-arm 6 is obtained more towards the rear of the snowmobile frame 9. The solution applied here for the electric snowmobile 1 can be seen in Fig. 5. In prior art discussed in the background, the connection points locate usually 15-25 cm in front of the location where the front end of the roller tunnel 11 (i.e. involving the endless drive track) locates, when looking the situation from the top side of the snowmobile 1. However, in the present invention, the rear connection points 13 for the lower suspension A-arms 6, may be placed close or very close to the front end of the roller tunnel 11; meaning the same as "close or very close to the lateral vertical plane along the line 11 in Fig. 5". This lateral, vertical plane is marked right at the front end of the roller tunnel 11. The prior art's rear connection points locate along the thin dashed line, while the present invention's rear connection points 13 locate along or near the thick horizontal (= the direction in this figure) intact line i.e. line 11. The rear connection point 13 can be seen in the figure near the intersection of the thick intact lines; applying to both connection points 13, respectively. The difference in the longitudinal placement (between prior art and the invention) is marked as "t"; shown in Fig. 5 between the horizontal intact and dashed lines. Indeed, because the snowmobile 1 according to the present invention now has more free space right in front of the roller tunnel (also laterally), the rear connection point 13 (where the more rear half (i.e. the lower locating rod in the point of view of this figure) of the A-arm intersects with a thicker dashed line) will locate right next to the lower corner of the roller tunnel. This optimal rear connection point 13 thus locates at or right next or adjacent to the longitudinal side edge 12 of the roller tunnel (see the longitudinally directed two thick intact lines in Fig. 5; the symmetrically drawn vertically aligned lines in Figure 5). Also, this location of rear connection point 13 is at or close to the longitudinal level shown as line 11, i.e. the front end

of the roller tunnel 11 (as also mentioned earlier). The tilted thick dashed lines on top of the part of the frame 9 depict the structural design of the frame 9 so that the impacts through the lower suspension A-arms 6 to frame 9 are partly carried by the triangular forming of the frame 9 consisting of the tilted thick lines and the thick intact line. The A-arms 5, 6 and the pyramid-shape structure (shown especially in Figures 3-4) make it possible that the impulse-type of forces distribute more smoothly towards the lower base of the frame 9, and this also happens because the front shock absorbers 4 are made lengthier than in prior art; this characteristic is illustrated especially in Figures 3-4 and 7-8. In summary, Figure 5 shows one of the most optimal locations, where the rear connection point 13 (or actually two of them) is desired to be placed, in order to enable proper shock absorbing properties and also long-term endurance of the vehicle in case of driving the snowmobile 1 in rough terrain.

[0055] Figure 6 illustrates a direct side view from the electric snowmobile 1, in an embodiment of the present invention. The front skis, the lower suspension A-arm, the front shock absorber, the spindle and the handle bar can especially be seen in the left hand (i.e. front) side of the frame of the electric snowmobile 1. Some covering structures and an encapsulating body can be also seen, where the driver's seat may be attached on top of the horizontal section of the encapsulating body. The central volume within the encapsulating body is meant for the battery package, and when applying "pouch cells"-based battery modules, the battery package will accommodate a hexahedronal space within the volume determined by the outer surfaces of the encapsulating body.

[0056] The tail end part also may also define a planar area between the bottom surface of the battery package and the endless drive track locating within the roller tunnel. The endless drive track usually involves protrusional shapes in order to make better contact with the snow during the riding in various different terrains.

[0057] An important design feature of the present invention is illustrated in Figure 6; namely the mutual positioning of the lower and upper suspension A-arms 6, 5. As shown with 90 degrees angles between different lines connecting four crucial connection points, the design thus involves the upper suspension A-arm 5 directly on top of the lower suspension A-arm 6. In other words, the upper and lower suspension A-arms have the same geometry, and alignment angles, i.e. thus locating directly as one on top of the other. Furthermore, the plane defined by the lower suspension A-arm 6 is parallel with the plane defined by the upper suspension A-arm 5. This parallelness will maintain all the time with any compression length activated with the front shock absorbers during driving. This has also the advantage that the driving posture will maintain pretty much the same, or at least as stable as possible, during bumpy driving, because the caster and camber angles (we define these later in more detail) of the snowmobile will remain practically the same all the time, no matter how much and how long the front

shock absorbers are in a compressed state during the driving.

[0058] From these design features, it becomes clear that the four relevant "node" locations within the snowmobile's frame structure are indeed connected by imaginative lines, which form four 90 degrees angles between one another, as Figure 6 shows.

[0059] The front shock absorbers 4, and the upper and lower suspension A-arms 5, 6 in the compressed situation in three different compression magnitudes are exemplified next in Figures 7 and 8. Also the camber and the caster angles of the snowmobile 1 are discussed in more detail.

[0060] Figure 7 illustrates the compression action made possible by the front shock absorbers 4, as a front view of the electric snowmobile 1. In this embodiment, the two front shock absorbers 4 are connected to the frame 9 so that the upper ends of both front shock absorbers 4 are supported by the top location of the pyramid-shaped structure in the front side of the frame 9. This can be seen in Fig. 7, where the top ends of the front shock absorbers 4 are connected in practice to the same support point within the frame structure; i.e. right below the handle bar. This support point locates along the longitudinal centre line of the snowmobile 1, marked with dashed-dotted line "s" in Figure 7. Naturally, also the handle bar locates symmetrically in view of the longitudinal centre line, to create a balanced snowmobile 1. A steering column is the axial element extending right below from the support point and the handle bar, right along the marking "s".

[0061] Now Figure 7 illustrates three different snowmobile positions (i.e. intrinsically within its own frame), where the amount of compression within the front shock absorbers 4 varies in three different ways. These positions can be seen in Figure 7 as examples, by a first neutral position, by a second half-compressed position and by a third fully-compressed position.

[0062] In the present embodiment, the upper suspension A-arm 5 has the same geometry as the lower suspension A-arm 6. Furthermore, the mirroring axis of the branches within the upper suspension A-arm 5 is parallel with the mirroring axis of the branches within the lower suspension A-arm 6. The upper and lower suspension A-arms 5, 6 locate in practice directly on top or approximately on top of one another, with parallel mirroring axis directions. Furthermore, both A-arms 5, 6 locate at the same distance from the vertically locating plane where the plane locates along the longitudinal central line of the snowmobile 1 (the vertical plane dividing the vehicle in symmetrical halves). In an embodiment, these positional characteristics of the upper and lower suspension A-arms 5, 6 apply in all compression magnitudes of the front shock absorbers 4, exemplified by three positions of the front part of the frame 9, as shown in Figures 7 and 8.

[0063] The above mentioned positional characteristics make it possible to obtain a constant or essentially constant camber angle (α) in relation to the above defined

vertical plane, across the whole compression or movement range of the front shock absorbers 4 (the top part of the frame moving along the axis "s"; with "moving" we mean an "oscillating" movement downwards and upwards in view of the level of the front skis).

[0064] Figure 8 illustrates the compression action made possible by the front shock absorbers 4, as a side view of the electric snowmobile 1. This describes the same action and functionality as Figure 7, but from a different angle.

[0065] Also Figure 8 illustrates three different snowmobile positions (i.e. intrinsically within its own frame), where the amount of compression within the front shock absorbers 4 varies in three different ways. These positions can be seen also in Figure 8 as examples, by a first neutral position, by a second half-compressed position and by a third fully-compressed position.

[0066] Also the caster angle (β) shown in Figure 8 may be kept as constant or as essentially constant in relation to a lateral vertical plane across the snowmobile 1 (shown as a vertical plane or line "r" across the area where the skis locate); this also applies across the whole compression or movement range of the front shock absorbers 4 (three positions also shown in Figure 8, as an example).

[0067] As can be seen from Figures 7-8, the upper suspension A-arm 5 locates in greater distance from the lower suspension A-arm 6, than in prior art solutions. This enables the front shock absorber's 4 length to be greater, which make it possible to obtain a greater compression range. This makes the shock absorbance properties better in very varying terrains and environments. The greater mutual distance between A-arms 5, 6 also make it possible to design a longer spindle 7. With a long spindle 7, the upper suspension A-arm 5 and the frame 9 will experience smaller impulses and forces than in prior art solutions applying a short spindle. A longer spindle or longer front shock absorbers are not possible in prior art solutions applying an internal combustion engine, because those engines, the required variable ratio transmission system and the gas exchange systems (e.g. pipes for exhaust gases) require large spaces which in the present invention is indeed used by the presented support structures at least partly. Therefore, the present technique in the traditional internal combustion engine-based snowmobiles does not allow the A-arms, other supporting elements and the shock absorbers to be designed in the way, which we have disclosed in connection with the present invention above, across its various embodiments.

[0068] The advantage of the functional efficiency in the front shock absorbers 4 because of the bigger space in the electric snowmobile's design, is that the bigger space enables using a longer structure in the front shock absorbers 4 together with the upper and lower suspension A-arms 5, 6. This structure creates very efficient shock absorbance properties in case of severe bumps faced along the driving of the snowmobile 1 in hard (i.e. varying) terrain. In prior art, the possible length of the front shock

absorbers is much shorter because there is restricted space in the area where the front shock absorbers must be placed. Therefore, the shock absorbance properties in prior art snowmobiles are notably poorer.

5 **[0069]** Proper materials suitable for the encapsulating body 2 and for the various rods of the support structure, and for the suspension A-arms 5, 6, for the spindle 7, and also for the front shock absorbers 4 (concerning the solid parts forming the pipe-like parts) applied in the frame 9
10 comprise aluminium, steel, stainless steel, carbon fiber, and composite materials in general. One or several from these materials may be selected when manufacturing the frame structure of the snowmobile 1. These materials act also as an electromagnetic interference (i.e. EMI) protection
15 means for the electric snowmobile 1.

[0070] The present invention may vary within the scope of the claims.

20 Claims

1. An electric snowmobile (1) with efficient shock absorbance properties, wherein the electric snowmobile (1) comprises:

25 - two skis at a front side of the electric snowmobile (1);
- an endless drive track, and a roller tunnel for the endless drive track;
30 - a camber angle (α) and a caster angle (β) as intrinsic parameters of the electric snowmobile (1);
- a frame (9), comprising a front part (8) of the frame, which front part (8) of the frame comprises:

35 - two upper suspension A-arms (5) and two lower suspension A-arms (6), wherein
- the upper and the lower suspension A-arms (5, 6) locate substantially on top of one another with a mutual distance, with mutually parallel mirroring angles of the A-arms (5, 6), for each pair of upper and lower suspension A-arms (5, 6) for each of the skis, and the electric snowmobile (1) further comprising
45 - front shock absorbers (4), whose top connection points locate adjacently at the same location, and essentially on a top of an essentially pyramid-shaped structure of the front part (8) of the frame (9), **characterized in that**

50 - a rear connection point (13) for the lower suspension A-arm (6) in both the left and right sides locates at or right next to a longitudinal side edge (12) of the roller tunnel, and further, the rear connection point (13) for the lower suspension

- A-arm (6) in both the left and right sides locates at or close to a lateral vertical plane along a front end (11) of the roller tunnel; and
 - the frame (9) comprising a triangular forming so that impacts through the lower suspension A-arms (6) to the frame (9) are partly carried by the triangular forming of the frame (9).
2. The electric snowmobile according to claim 1, **characterized in that** the front part (8) of the frame (9) comprises a spindle (7) per each ski, which spindle (7) is a relatively long vertical element connected to each of the skis, and where each A-arm (5, 6) is fixed to the spindle (7) in a location where two rods forming an A-arm (5, 6) are connected to one another, and the upper and lower suspension A-arms (5, 6) are attached to different heights along the spindle (7), respectively for both spindles (7).
3. The electric snowmobile according to claim 1, **characterized in that**
- the upper left suspension A-arm (5) is fixed to the top of the left spindle (7), the lower left suspension A-arm (6) is fixed to the left spindle (7) so that the mutual distance is larger than the distance from the lower left suspension A-arm's (6) fixation point with the left spindle (7) to a bottom surface of the left ski, and
 - the upper right suspension A-arm (5) is fixed to the top of the right spindle (7), the lower right suspension A-arm (6) is fixed to the right spindle (7) so that the mutual distance is larger than the distance from the lower right suspension A-arm's (6) fixation point with the right spindle (7) to a bottom surface of the right ski.
4. The electric snowmobile according to claim 1, **characterized in that** the frame (9) is configured so that:
- determining four end points including the two outer ends in each of the upper and lower suspension A-arms (5, 6) in the left side of the snowmobile (1),
 - designing the locations of the four end points so that they define together corners of a rectangle,
 - determining further four end points including the two outer ends in each of the upper and lower suspension A-arms (5, 6) in the right side of the snowmobile (1),
 - designing the locations of the further four end points so that they define together corners of another rectangle.
5. The electric snowmobile according to claim 1, **characterized in that** the snowmobile (1) is configured to obtain a constant or essentially constant camber angle (α) in relation to a longitudinally extending vertical plane (s) across the whole compression or movement range of the front shock absorbers (4), where the longitudinally extending vertical plane (s) locates along the longitudinal central line of the snowmobile (1).
6. The electric snowmobile according to claim 1, **characterized in that** the snowmobile (1) is configured to obtain a constant or essentially constant caster angle (β) in relation to a transversally extending vertical plane (r) across the whole compression or movement range of the front shock absorbers (4), where the transversally extending vertical plane (r) locates across the locations of the snowmobile (1) where the skis are attached to the respective spindle (7).
7. The electric snowmobile according to claim 1, **characterized in that** the electric snowmobile (1) comprises:
- an encapsulating body (2), comprising a part having a hexahedronally shaped inner surface;
 - a driver's seat (3) directly installed on top of a central horizontal part of the encapsulating body (2);
 - a battery package in the hexahedronally shaped space defined by the part of the encapsulating body (2); and
 - one or more vibration isolators (10) configured between the battery package and the encapsulating body (2), for diminishing the effects from outer shocks towards the battery package.
- ### Patentansprüche
1. Elektrisches Schneemobil (1) mit effizienten Stoßdämpfungseigenschaften, wobei das elektrische Schneemobil (1) Folgendes umfasst:
- zwei Skier an der Vorderseite des elektrischen Schneemobils (1);
 - eine kontinuierliche Antriebsbahn und einen Rollentunnel für die kontinuierliche Antriebsbahn;
 - einen Sturzwinkel (α) und einen Nachlaufwinkel (β) als intrinsische Parameter des elektrischen Schneemobils (1);
 - einen Rahmen (9), umfassend einen vorderen Teil (8) des Rahmens, wobei der vordere Teil (8) des Rahmens Folgendes umfasst:
 - zwei obere Aufhängungs-A-Lenker (5) und zwei untere Aufhängungs-A-Lenker (6), wobei
 - der obere und der untere Aufhängungs-A-Lenker (5, 6) im Wesentlichen mit einem gegenseitigen Abstand übereinander an-

geordnet sind, mit zueinander parallelen Spiegelwinkeln der A-Lenker (5, 6) für jedes Paar von oberen und unteren Aufhängungs-A-Lenkern (5, 6) für jeden der Skier, und das elektrische Schneemobil (1) ferner umfassend:

- vordere Stoßdämpfer (4), deren obere Verbindungspunkte sich nebeneinander an derselben Stelle befinden, und im Wesentlichen auf einer Spitze einer im Wesentlichen pyramidenförmigen Struktur des vorderen Teils (8) des Rahmens (9), **dadurch gekennzeichnet, dass**
- ein hinterer Verbindungspunkt (13) für den unteren Aufhängungs-A-Lenker (6) sowohl auf der linken als auch auf der rechten Seite an oder direkt neben einer Längsseitenkante (12) des Rolltunnels angeordnet ist, und ferner der hintere Verbindungspunkt (13) für den unteren Aufhängungs-A-Lenker (6) sowohl auf der linken als auch auf der rechten Seite an oder nahe einer seitlichen vertikalen Ebene entlang einem vorderen Ende (11) des Rolltunnels angeordnet ist; und
- der Rahmen (9) eine dreieckige Bildung umfasst, sodass Einschläge durch die unteren Aufhängungs-A-Lenker (6) auf den Rahmen (9) teilweise von der dreieckigen Bildung des Rahmens (9) getragen werden.

2. Elektrisches Schneemobil nach Anspruch 1, **dadurch gekennzeichnet, dass** der vordere Teil (8) des Rahmens (9) eine Spindel (7) für jeden Ski umfasst, wobei die Spindel (7) ein relativ langes vertikales Element ist, das mit jedem der Skier verbunden ist, und wobei jeder A-Lenker (5, 6) an der Spindel (7) an einer Stelle befestigt ist, an der zwei Stangen, die einen A-Arm (5, 6) bilden, miteinander verbunden sind, und der obere und der untere Aufhängungs-A-Arm (5, 6) in unterschiedlichen Höhen entlang der Spindel (7) jeweils für beide Spindeln (7) angebracht sind.

3. Elektrisches Schneemobil nach Anspruch 1, **dadurch gekennzeichnet, dass**

- der obere linke Aufhängungs-A-Lenker (5) an der Oberseite der linken Spindel (7) befestigt ist, der untere linke Aufhängungs-A-Lenker (6) an der linken Spindel (7) befestigt ist, sodass der gegenseitige Abstand größer ist als der Abstand vom Befestigungspunkt des unteren linken Aufhängungs-A-Lenkens (6) mit der linken Spindel

(7) zu einer unteren Oberfläche des linken Skis, und

- der obere rechte Aufhängungs-A-Lenker (5) an der Oberseite der rechten Spindel (7) befestigt ist, der untere rechte Aufhängungs-A-Lenker (6) an der rechten Spindel (7) befestigt ist, sodass der gegenseitige Abstand größer ist als der Abstand vom Befestigungspunkt des unteren rechten Aufhängungs-A-Lenkens (6) mit der rechten Spindel (7) zu einer unteren Oberfläche des rechten Skis.

4. Elektrisches Schneemobil nach Anspruch 1, **dadurch gekennzeichnet, dass** der Rahmen (9) konfiguriert ist zum:

- Bestimmen von vier Endpunkten, einschließlich der beiden äußeren Enden in jedem der oberen und unteren Aufhängungs-A-Lenker (5, 6) auf der linken Seite des Schneemobils (1),
- Gestalten der Stellen der vier Endpunkte so, dass sie gemeinsam die Ecken eines Rechtecks definieren,
- Bestimmen von vier weiteren Endpunkten, einschließlich der beiden äußeren Enden in jedem der oberen und unteren Aufhängungs-A-Lenker (5, 6) auf der rechten Seite des Schneemobils (1),
- Gestalten der Positionen der weiteren vier Endpunkte, sodass sie gemeinsam die Ecken eines weiteren Rechtecks definieren.

5. Elektrisches Schneemobil nach Anspruch 1, **dadurch gekennzeichnet, dass** das Schneemobil (1) konfiguriert ist, um einen konstanten oder im Wesentlichen konstanten Sturzwinkel (α) in Bezug auf eine sich in Längsrichtung erstreckende vertikale Ebene (s) über den gesamten Einfederungs- oder Bewegungsbereich der vorderen Stoßdämpfer (4) zu erhalten, wobei sich die sich in Längsrichtung erstreckende vertikale Ebene (s) entlang der Längsmittellinie des Schneemobils (1) befindet.

6. Elektrisches Schneemobil nach Anspruch 1, **dadurch gekennzeichnet, dass** das Schneemobil (1) konfiguriert ist, um einen konstanten oder im Wesentlichen konstanten Nachlaufwinkel (β) in Bezug auf eine sich transversal erstreckende vertikale Ebene (r) über den gesamten Einfederungs- oder Bewegungsbereich der vorderen Stoßdämpfer (4) zu erhalten, wobei sich die sich transversal erstreckende vertikale Ebene (r) über die Stellen des Schneemobils (1) befindet, an denen die Skier an der jeweiligen Spindel (7) befestigt sind.

7. Elektrisches Schneemobil nach Anspruch 1, **dadurch gekennzeichnet, dass** das elektrische Schneemobil (1) Folgendes umfasst:

- einen Einkapselungskörper (2), umfassend einen Teil mit einer hexaedrisch geformten inneren Oberfläche;
- einen Fahrersitz (3), der direkt auf einem mittleren horizontalen Teil des Einkapselungskörpers (2) angebracht ist;
- eine Batteriepackung in dem hexaedrisch geformten Raum, der durch den Teil des Einkapselungskörpers (2) definiert ist; und
- einen oder mehrere Schwingungsisolatoren (10), die zwischen der Batteriepackung und dem Einkapselungskörper (2) angeordnet sind, um die Auswirkungen von äußeren Stößen auf die Batteriepackung zu verringern.

Revendications

1. Motoneige électrique (1) dotée de propriétés d'absorption des chocs efficaces, dans laquelle la motoneige électrique (1) comprend :

- deux skis à l'avant de la motoneige électrique (1) ;
- une piste d'entraînement sans fin et un tunnel à rouleaux pour la piste d'entraînement sans fin ;
- un angle de carrossage (α) et un angle de chasse (β) comme paramètres intrinsèques de la motoneige électrique (1) ;
- un cadre (9), comprenant une partie avant (8) du cadre, laquelle partie avant (8) du cadre comprend :

- deux bras triangulaires de suspension supérieurs (5) et deux bras triangulaires de suspension inférieurs (6), dans laquelle
- les bras triangulaires de suspension supérieur et inférieur (5, 6) sont situés sensiblement l'un au-dessus de l'autre avec une distance mutuelle, avec des angles de miroir mutuellement parallèles des bras triangulaires (5, 6), pour chaque paire de bras de suspension triangulaires supérieur et inférieur (5, 6) pour chacun des skis, et la motoneige électrique (1) comprenant également
- des amortisseurs avant (4), dont les points de connexion supérieurs sont situés de manière adjacente au même endroit, et essentiellement sur le sommet d'une structure essentiellement pyramidale de la partie avant (8) du cadre (9), **caractérisée en ce que**
- un point de connexion arrière (13) pour le bras triangulaire de suspension inférieur (6) des côtés gauche et droit se situe au niveau ou juste à côté d'un bord latéral longitudinal (12) du tunnel à rouleaux, et également, le point de connexion arrière (13) pour le bras

triangulaire de suspension inférieur (6) des côtés gauche et droit se situe au niveau ou à proximité d'un plan vertical latéral le long d'une extrémité avant (11) du tunnel à rouleaux ; et

- le cadre (9) comprenant une forme triangulaire de sorte que les impacts à travers les bras triangulaires de suspension inférieurs (6) sur le cadre (9) sont en partie supportés par la forme triangulaire du cadre (9).

2. Motoneige électrique selon la revendication 1, **caractérisée en ce que** la partie avant (8) du cadre (9) comprend un axe (7) pour chaque ski, lequel axe (7) est un élément vertical relativement long relié à chacun des skis, et où chaque bras triangulaire (5, 6) est fixé à l'axe (7) dans un emplacement où deux tiges formant un bras triangulaire (5, 6) sont reliées l'une à l'autre, et les bras triangulaires de suspension supérieur et inférieur (5, 6) sont fixés à différentes hauteurs le long de l'axe (7), respectivement pour les deux axes (7).

3. Motoneige électrique selon la revendication 1, **caractérisée en ce que**

- le bras triangulaire de suspension supérieur gauche (5) est fixé au sommet de l'axe gauche (7), le bras triangulaire de suspension inférieur gauche (6) est fixé à l'axe gauche (7) de sorte que la distance mutuelle soit supérieure à la distance entre le point de fixation du bras triangulaire de suspension inférieur gauche (6) avec l'axe gauche (7) et une surface inférieure du ski gauche, et
- le bras triangulaire de suspension supérieur droit (5) est fixé au sommet de l'axe droit (7), le bras triangulaire de suspension inférieur droit (6) est fixé à l'axe droit (7) de sorte que la distance mutuelle soit supérieure à la distance entre le point de fixation du bras triangulaire de suspension inférieur droit (6) avec l'axe droit (7) et une surface inférieure du ski droit.

4. Motoneige électrique selon la revendication 1, **caractérisée en ce que** le cadre (9) est configuré de telle sorte que :

- la détermination de quatre points d'extrémité comportant les deux extrémités extérieures de chacun des bras triangulaires de suspension supérieur et inférieur (5, 6) du côté gauche de la motoneige (1),
- la conception des emplacements des quatre points d'extrémité de manière à ce qu'ils définissent ensemble les coins d'un rectangle,
- la détermination de quatre points d'extrémité

- supplémentaires comportant les deux extrémités extérieures de chacun des bras triangulaires de suspension supérieur et inférieur (5, 6) du côté droit de la motoneige (1),
- la conception des emplacements des quatre points d'extrémité supplémentaires de manière à ce qu'ils définissent ensemble les coins d'un autre rectangle.
- 5
5. Motoneige électrique selon la revendication 1, **caractérisée en ce que** la motoneige (1) est configurée pour obtenir un angle de carrossage constant ou essentiellement constant (α) par rapport à un plan vertical se prolongeant longitudinalement (s) sur toute la plage de compression ou de mouvement des amortisseurs avant (4), où le plan vertical se prolongeant longitudinalement (s) se situe le long de la ligne centrale longitudinale de la motoneige (1).
- 10
- 15
- 20
- 25
- 30
6. Motoneige électrique selon la revendication 1, **caractérisée en ce que** la motoneige (1) est configurée pour obtenir un angle de chasse constant ou essentiellement constant (β) par rapport à un plan vertical se prolongeant transversalement (r) sur toute la plage de compression ou de mouvement des amortisseurs avant (4), où le plan vertical se prolongeant transversalement (r) se situe sur les emplacements de la motoneige (1) où les skis sont fixés à l'axe respectif (7).
- 35
- 40
- 45
- 50
- 55
7. Motoneige électrique selon la revendication 1, **caractérisée en ce que** la motoneige électrique (1) comprend :
- un corps d'encapsulation (2), comprenant une partie ayant une surface intérieure de forme hexaédrique ;
 - un siège conducteur (3) installé directement sur une partie horizontale centrale du corps d'encapsulation (2) ;
 - un boîtier de batterie dans l'espace de forme hexaédrique défini par la partie du corps d'encapsulation (2) ; et
 - un ou plusieurs isolateurs de vibrations (10) configurés entre le boîtier de batterie et le corps d'encapsulation (2), pour diminuer les effets des chocs extérieurs sur le boîtier de batterie.

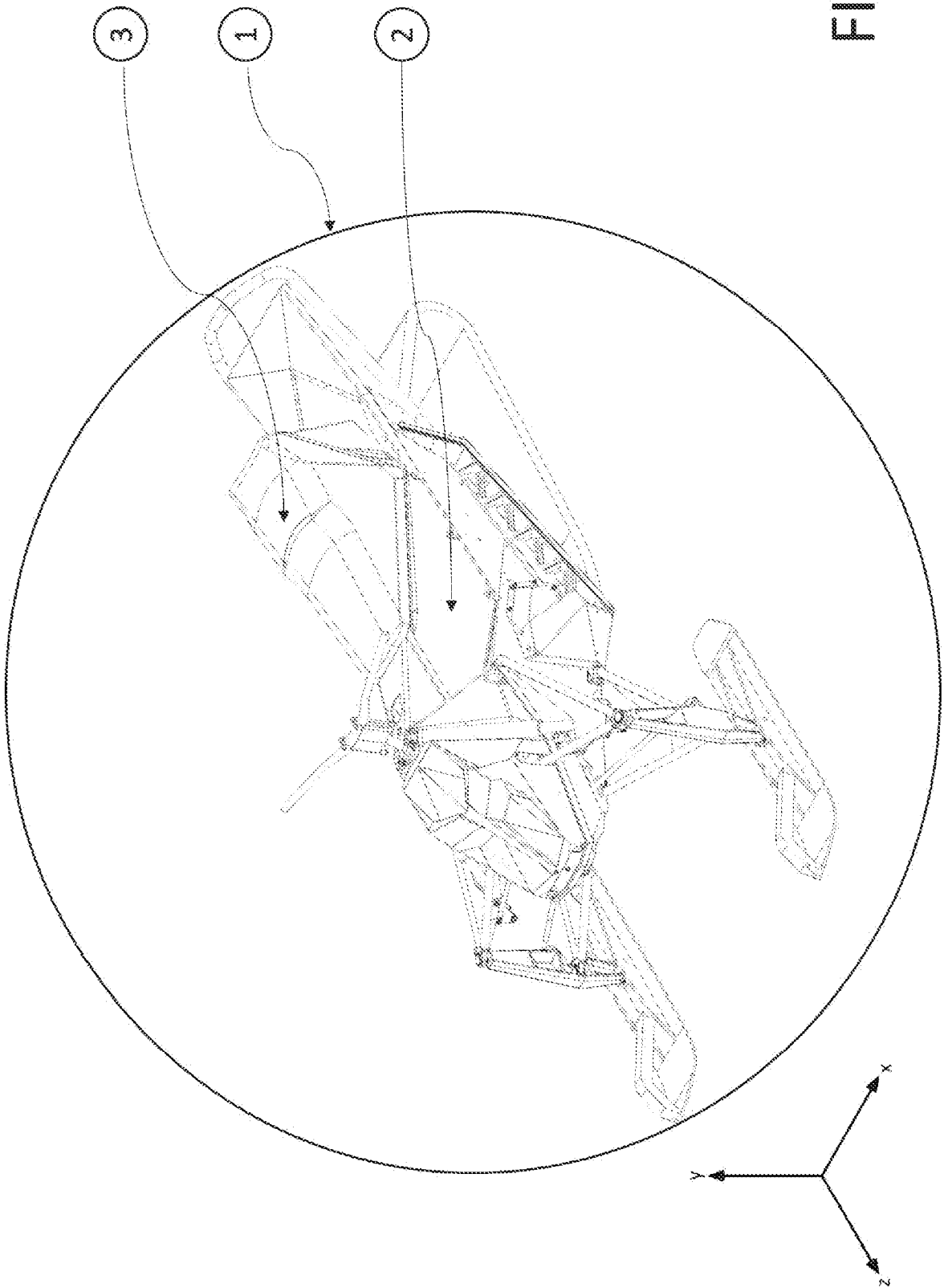

FIG. 1

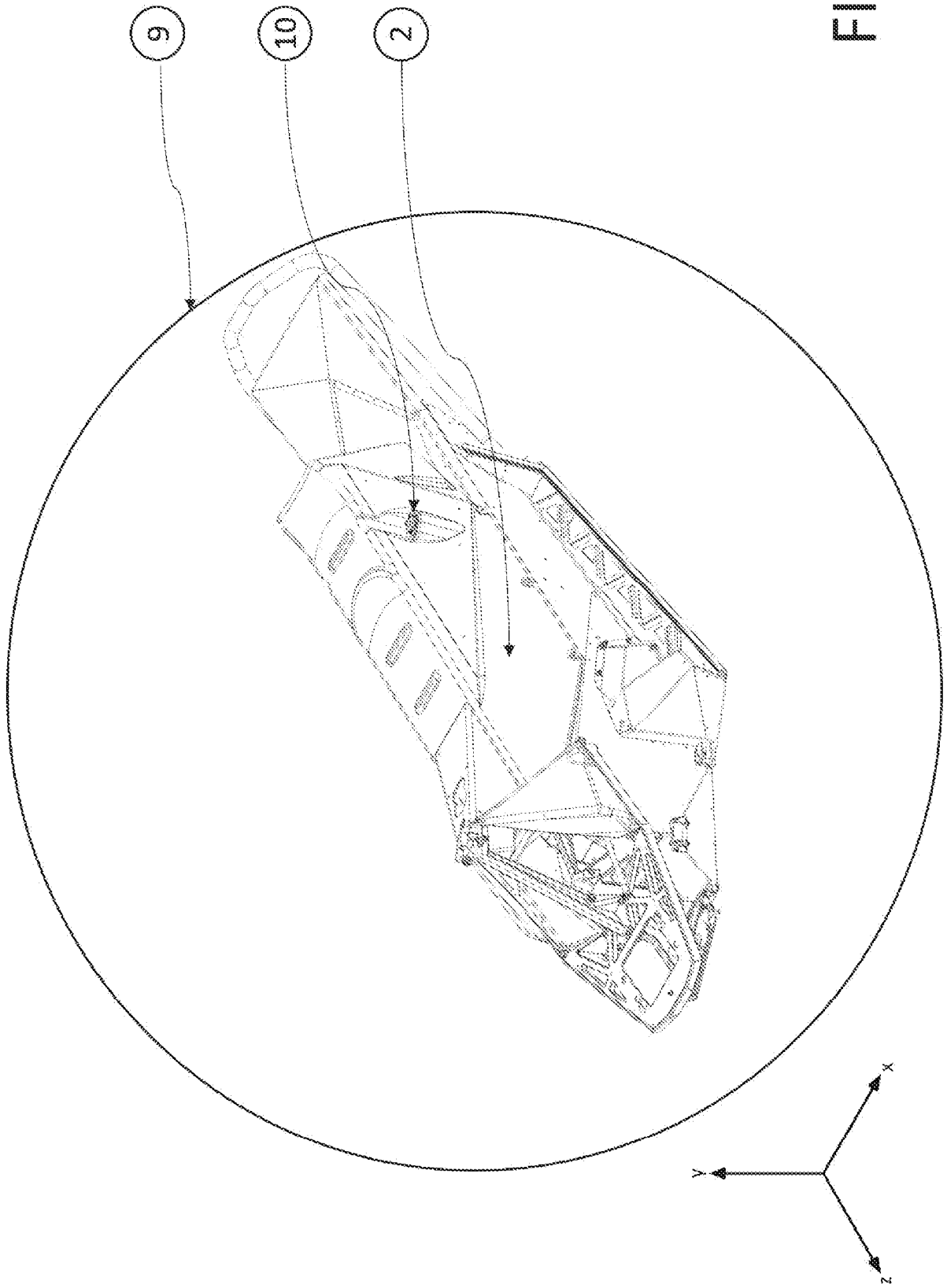

FIG. 2

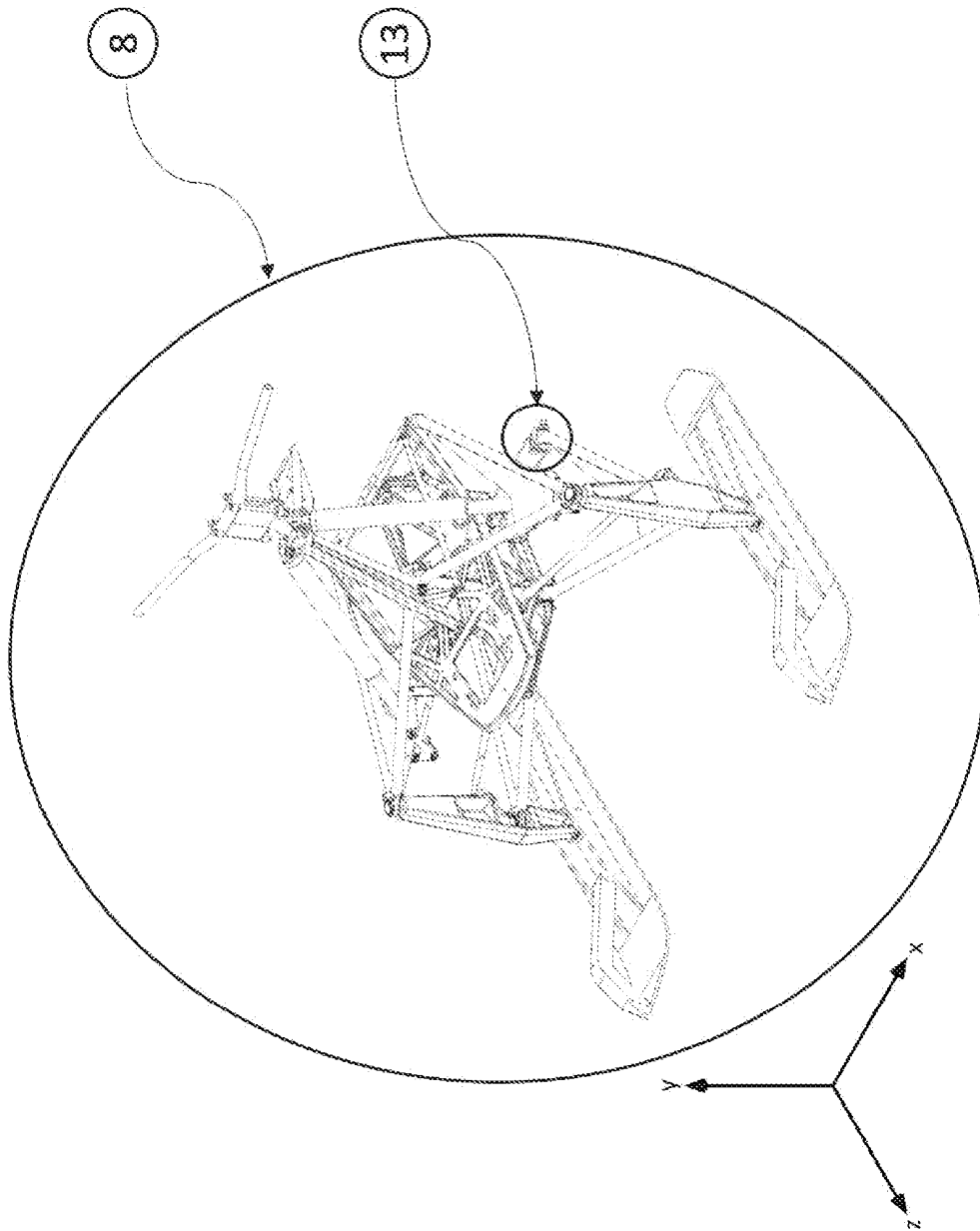

FIG. 3

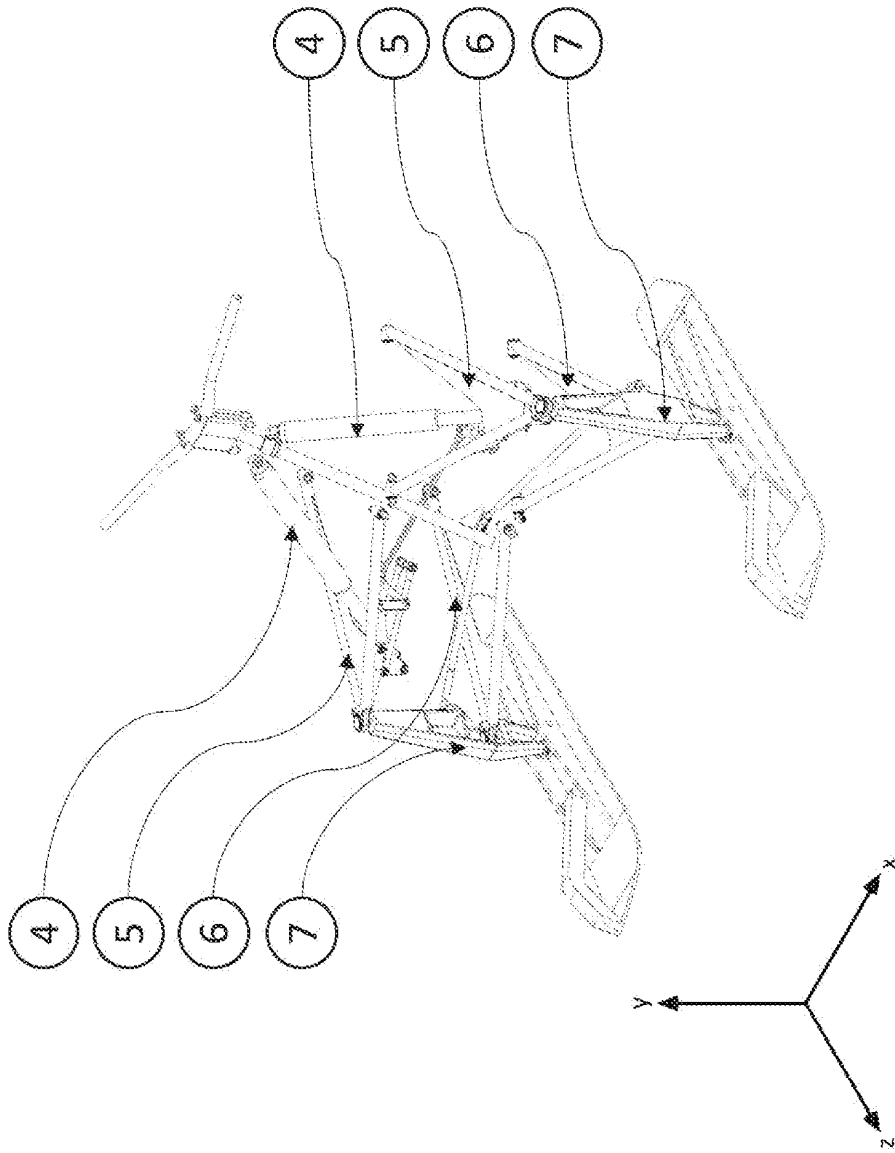

FIG. 4

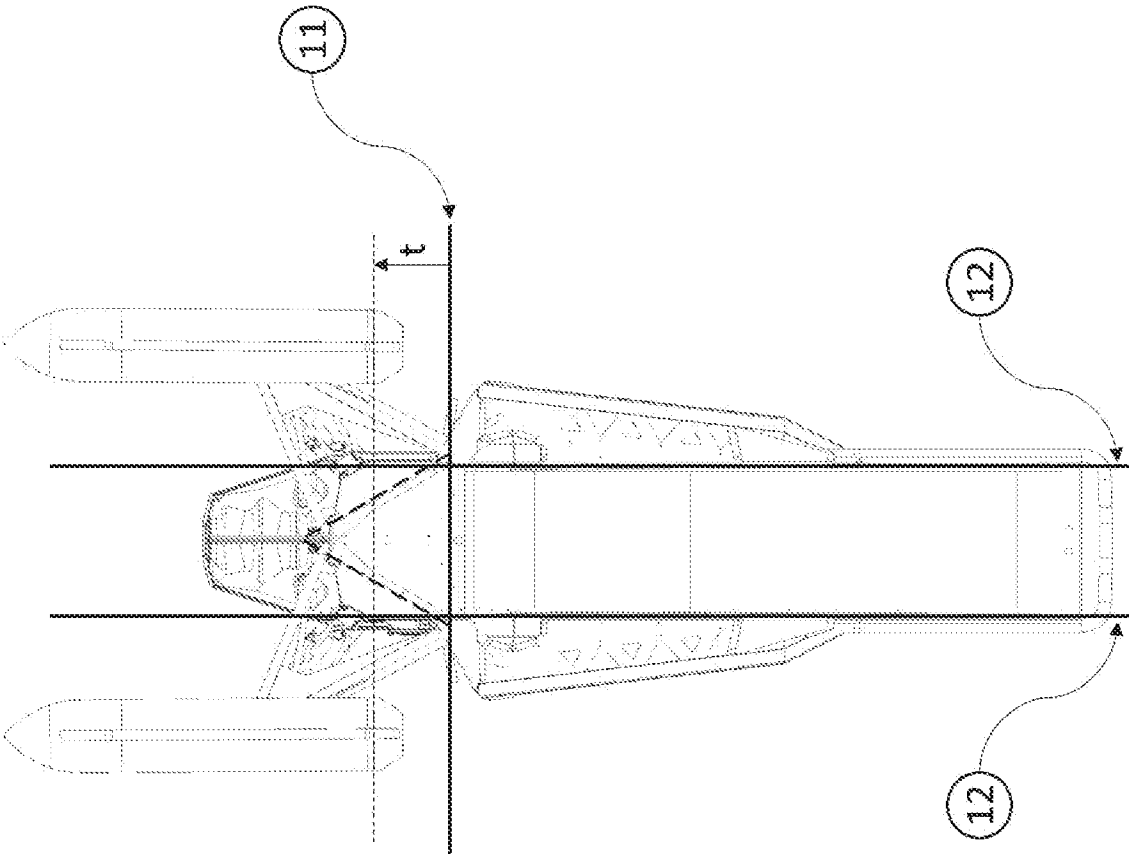
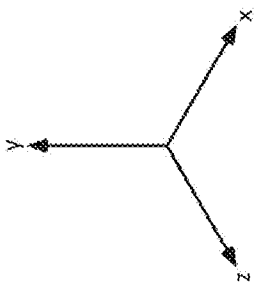

FIG. 5



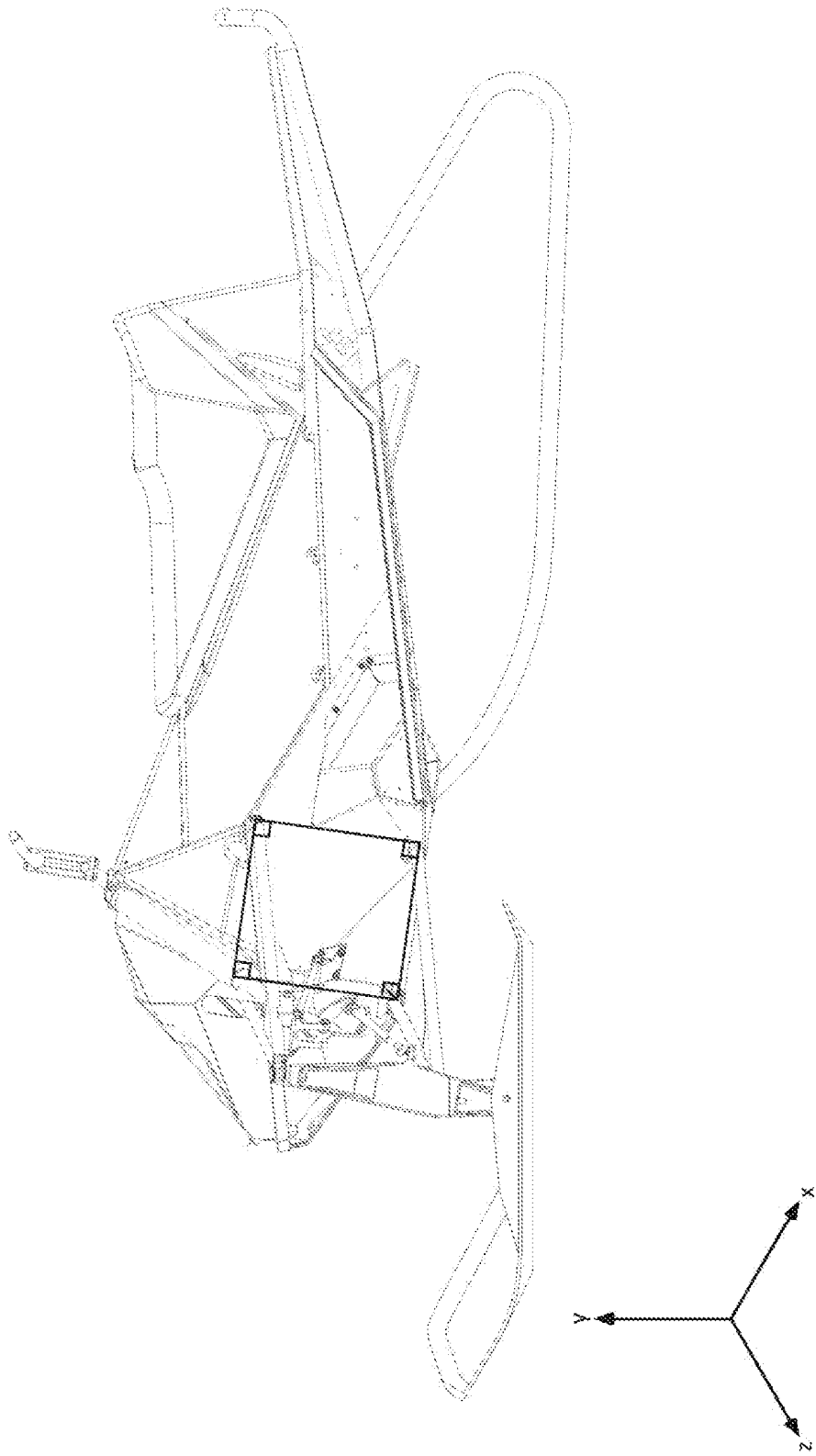

FIG. 6

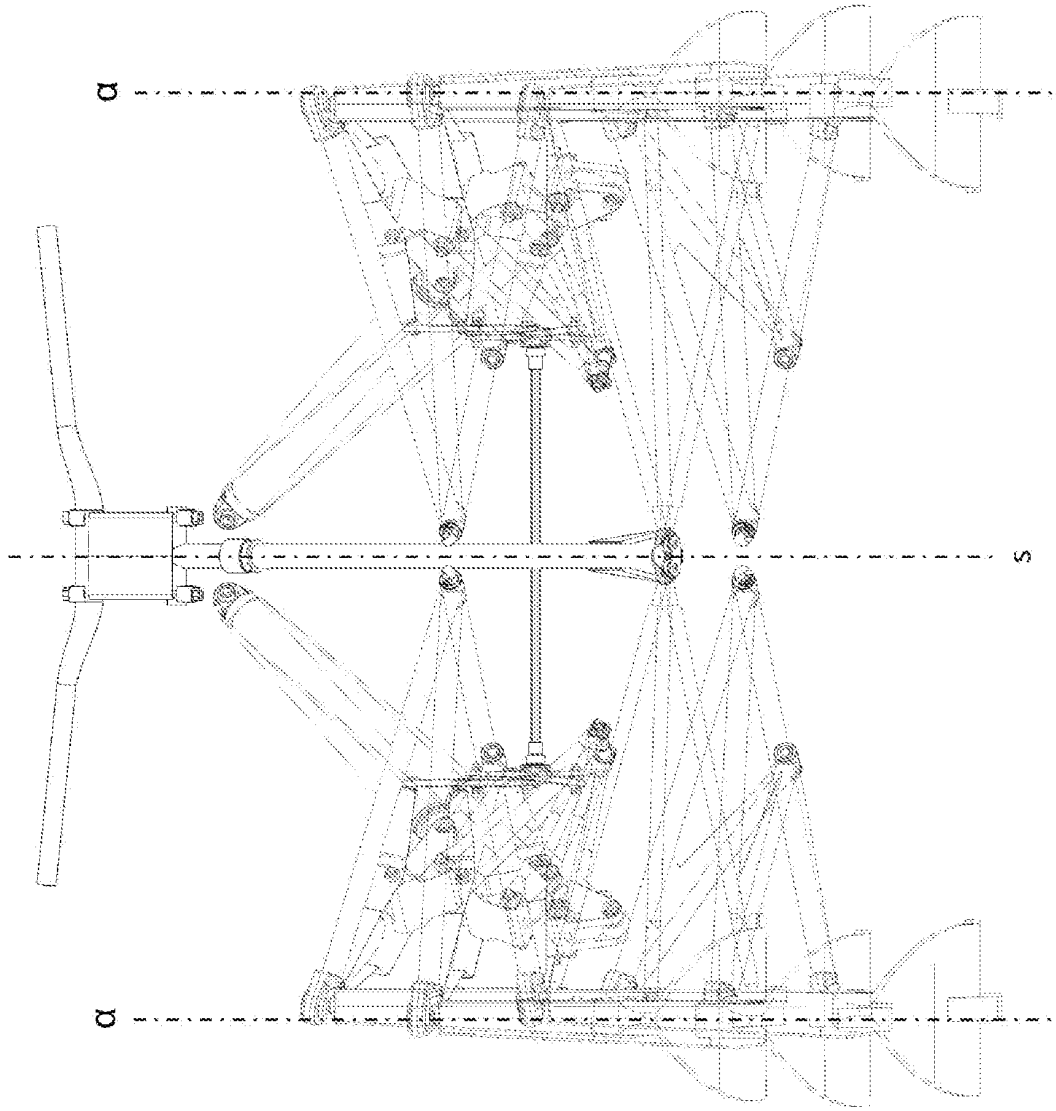
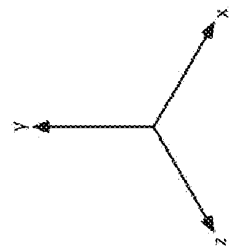

FIG. 7



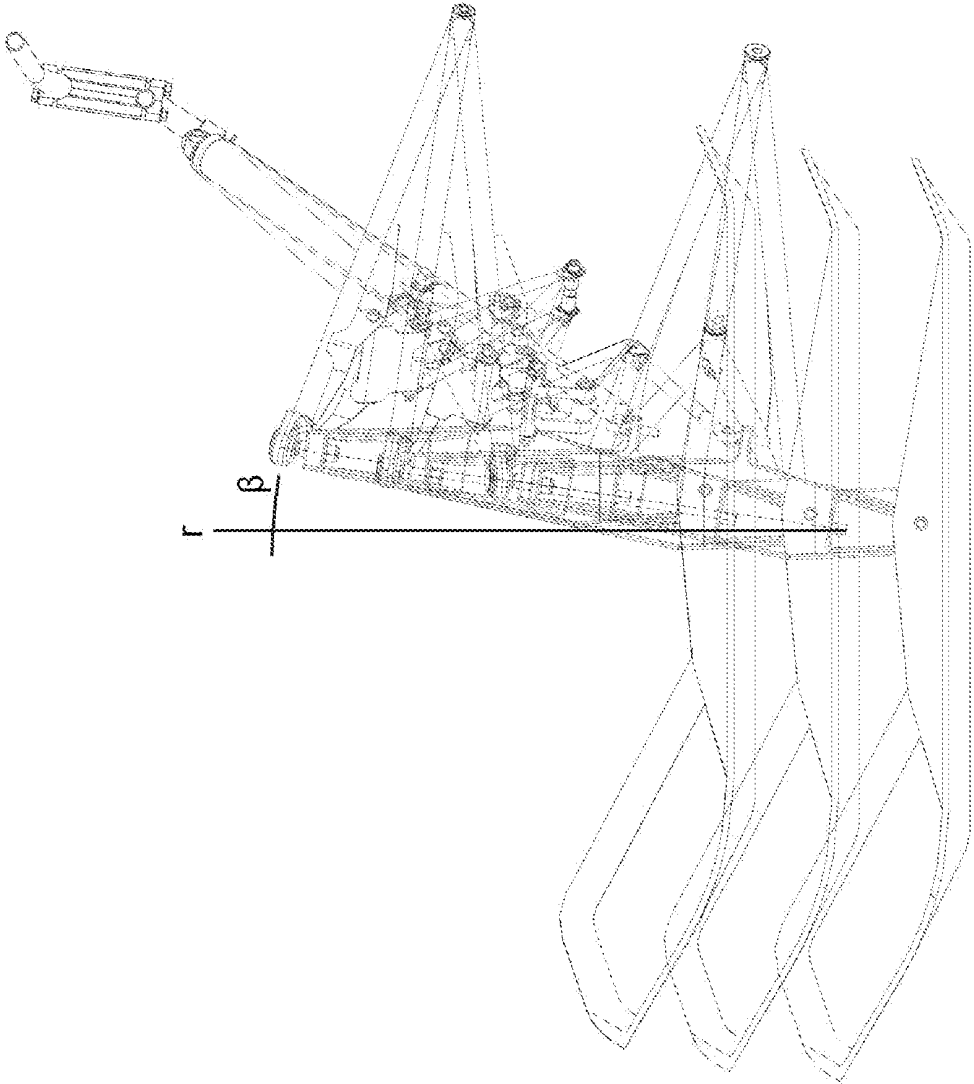
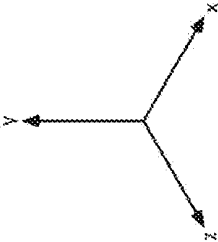

FIG. 8



REFERENCES CITED IN THE DESCRIPTION

This list of references cited by the applicant is for the reader's convenience only. It does not form part of the European patent document. Even though great care has been taken in compiling the references, errors or omissions cannot be excluded and the EPO disclaims all liability in this regard.

Patent documents cited in the description

- FI 20175471 [0004] [0007]
- US 20080173491 A, Fecteau [0008]
- CA 2478003, Väisänen [0009]
- EP 1798081 A, Tonoli [0010]
- US 9327789 B, Vezina [0011]
- US 5503242 A, Jeffers [0012]
- US 20170305500 A, Vigen [0013]