



US010196102B2

(12) **United States Patent**  
**Pattyn**

(10) **Patent No.:** **US 10,196,102 B2**

(45) **Date of Patent:** **\*Feb. 5, 2019**

(54) **SNOWMOBILE TRACK STUD SUPPORT**

(56) **References Cited**

(71) Applicant: **Liberty Products, Inc.**, Ravenna, MI (US)

U.S. PATENT DOCUMENTS

(72) Inventor: **Ronald C. Pattyn**, Ravenna, MI (US)

D157,905 S	3/1950	Risk	
3,973,808 A	8/1976	Janssen et al.	
4,070,071 A *	1/1978	Caravito	B60C 11/02 305/180

(73) Assignee: **Liberty Products, Inc.**, Ravenna, MI (US)

5,234,266 A	8/1993	Musselman et al.	
5,273,351 A	12/1993	Rubel	
5,299,860 A	4/1994	Anderson	
5,685,621 A	11/1997	Nugent	
5,690,398 A	11/1997	Pribyl	
5,707,123 A	1/1998	Grob	
5,716,112 A	2/1998	Staszak	
5,897,177 A	4/1999	Bergstrom	
5,921,642 A	7/1999	Tschida	
6,109,705 A	8/2000	Courtemanche	
6,203,126 B1	3/2001	Harguth	

(\* ) Notice: Subject to any disclaimer, the term of this patent is extended or adjusted under 35 U.S.C. 154(b) by 0 days.

This patent is subject to a terminal disclaimer.

(21) Appl. No.: **15/004,057**

(22) Filed: **Jan. 22, 2016**

(65) **Prior Publication Data**  
US 2016/0137241 A1 May 19, 2016

OTHER PUBLICATIONS

U.S. Appl. No. 61/339,904, filed Mar. 11, 2010 (17 Pages).

*Primary Examiner* — Kip T Kotter

(74) *Attorney, Agent, or Firm* — Price Heneveld LLP

**Related U.S. Application Data**

(63) Continuation of application No. 13/593,320, filed on Aug. 23, 2012, now Pat. No. 9,242,685.

(60) Provisional application No. 61/527,483, filed on Aug. 25, 2011.

(51) **Int. Cl.**  
**B62D 55/28** (2006.01)  
**B62M 27/02** (2006.01)

(57) **ABSTRACT**

A snowmobile track stud support includes a base configured to be coupled to a track of a snowmobile. A first boss extends from the base. The first boss includes a distal end having a boss aperture within which a stud can be disposed. A second boss extends from the base. The second boss includes a distal end with a boss aperture within which a stud can be disposed. A support flange extends from at least one of the first and second bosses and is disposed between the first and second bosses. The support flange includes a peak that projects away from the base. The distance from the peak to the base is greater than the distance from the distal end of the first boss to the base.

(52) **U.S. Cl.**  
CPC ..... **B62D 55/286** (2013.01); **B62D 55/28** (2013.01); **B62M 2027/027** (2013.01)

(58) **Field of Classification Search**  
CPC ..... B62D 55/26; B62D 55/28; B62D 55/286  
See application file for complete search history.

**17 Claims, 22 Drawing Sheets**

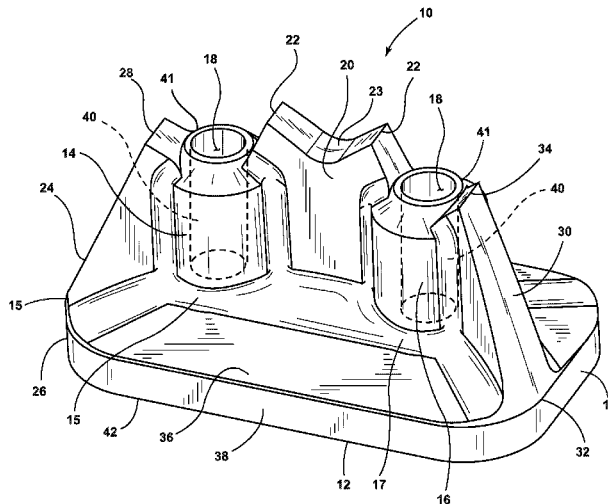

(56)

**References Cited**

U.S. PATENT DOCUMENTS

6,213,573	B1	4/2001	Nakayama	
6,296,330	B1	10/2001	Hall	
6,609,772	B2	8/2003	Musselman et al.	
7,377,601	B2	5/2008	Katoh et al.	
7,380,628	B2	6/2008	Bedard	
7,712,846	B2	5/2010	Schindler et al.	
7,845,741	B2	12/2010	Musselman	
9,004,618	B1	4/2015	Delisle et al.	
9,096,284	B2	8/2015	Meulemans	
9,242,685	B2*	1/2016	Pattyn .....	B62D 55/286
2004/0108772	A1*	6/2004	Pribyl .....	B62D 55/24 305/178
2005/0168068	A1	8/2005	Courtemanche et al.	
2006/0273660	A1	12/2006	Dandurand et al.	
2007/0052292	A1	3/2007	Musselman	
2012/0299372	A1	11/2012	Kruger	

\* cited by examiner

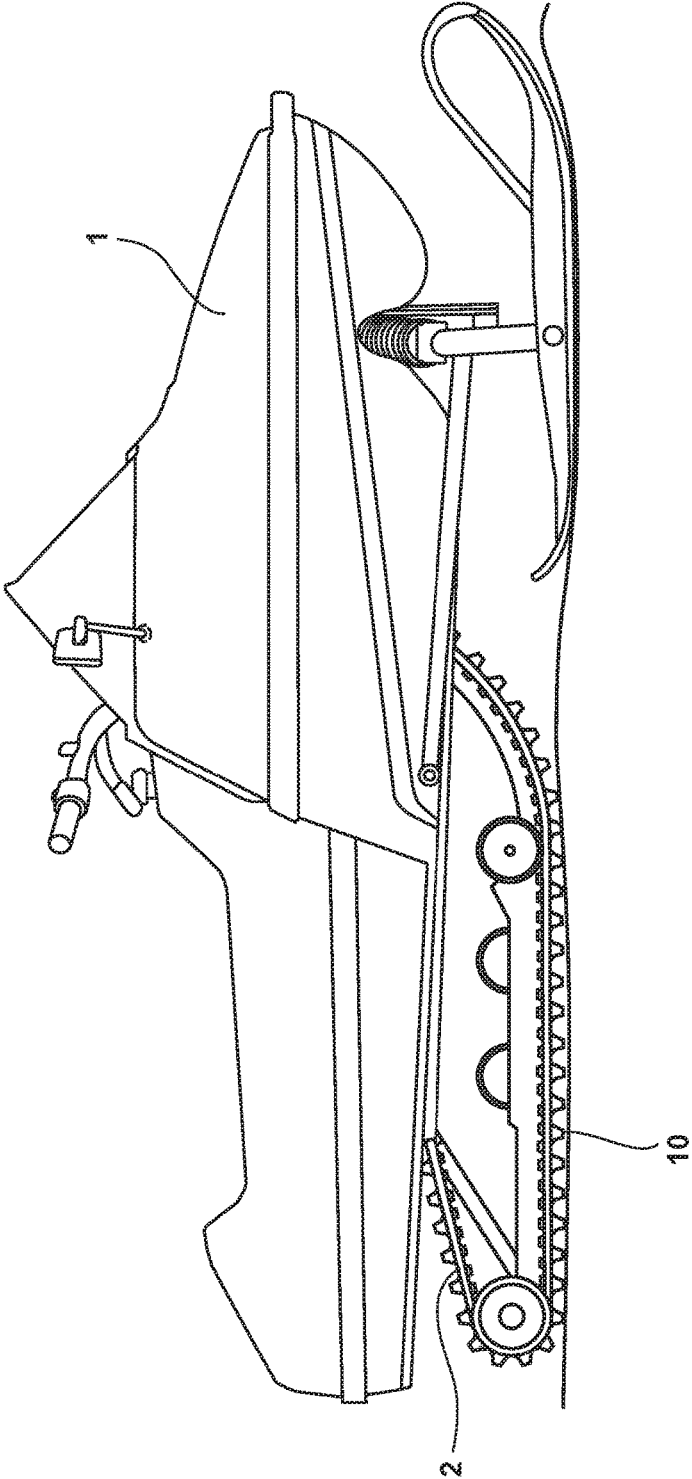

FIG. 1

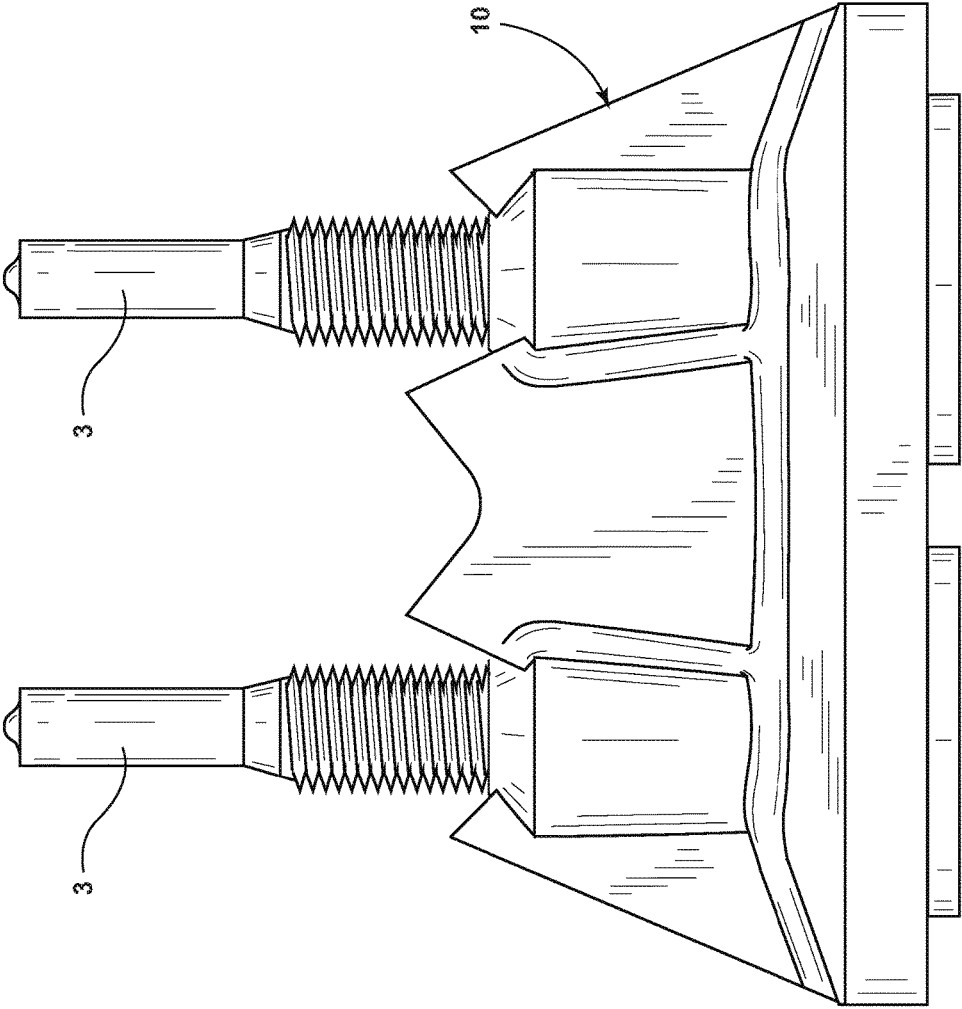

FIG. 2

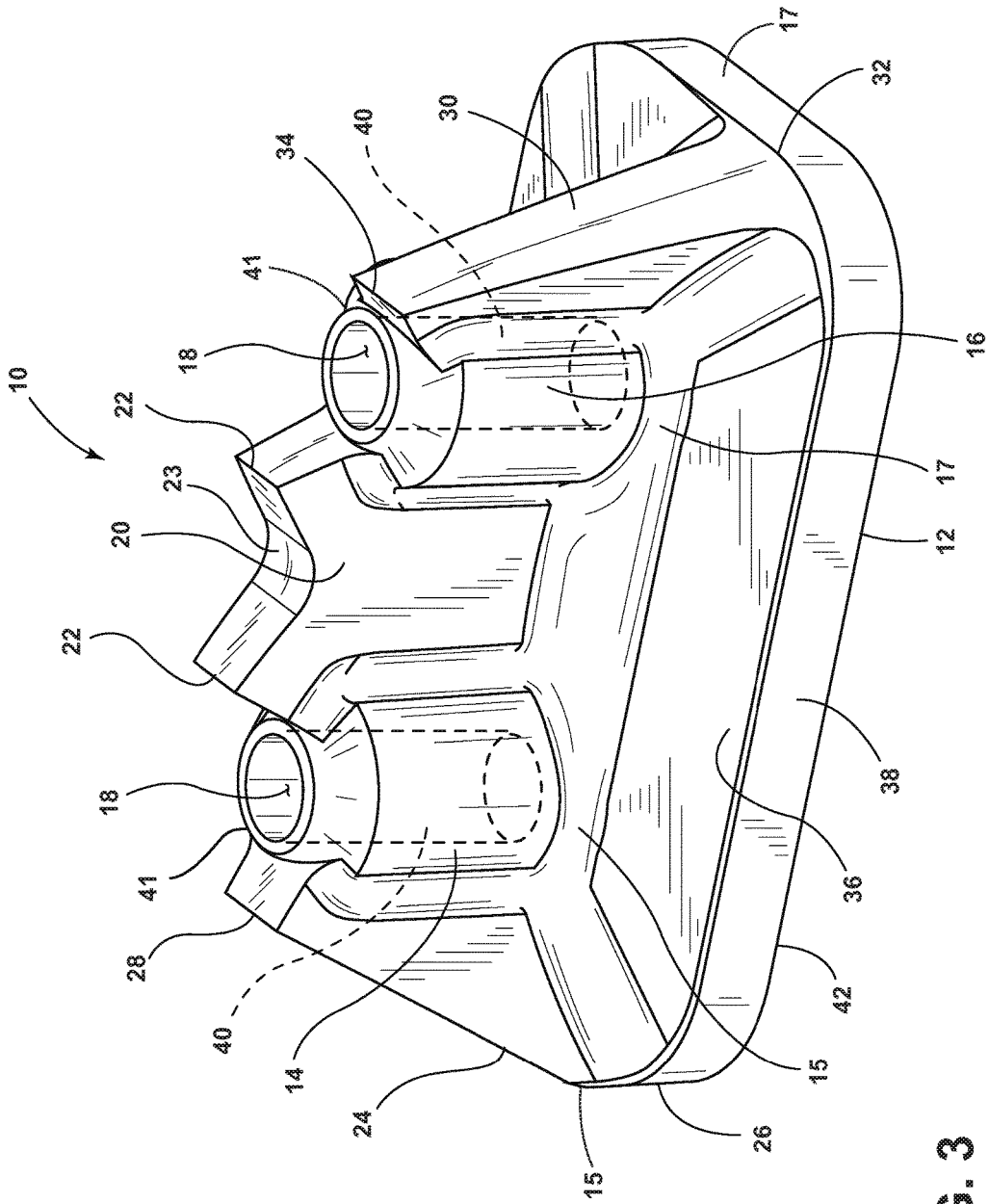

FIG. 3

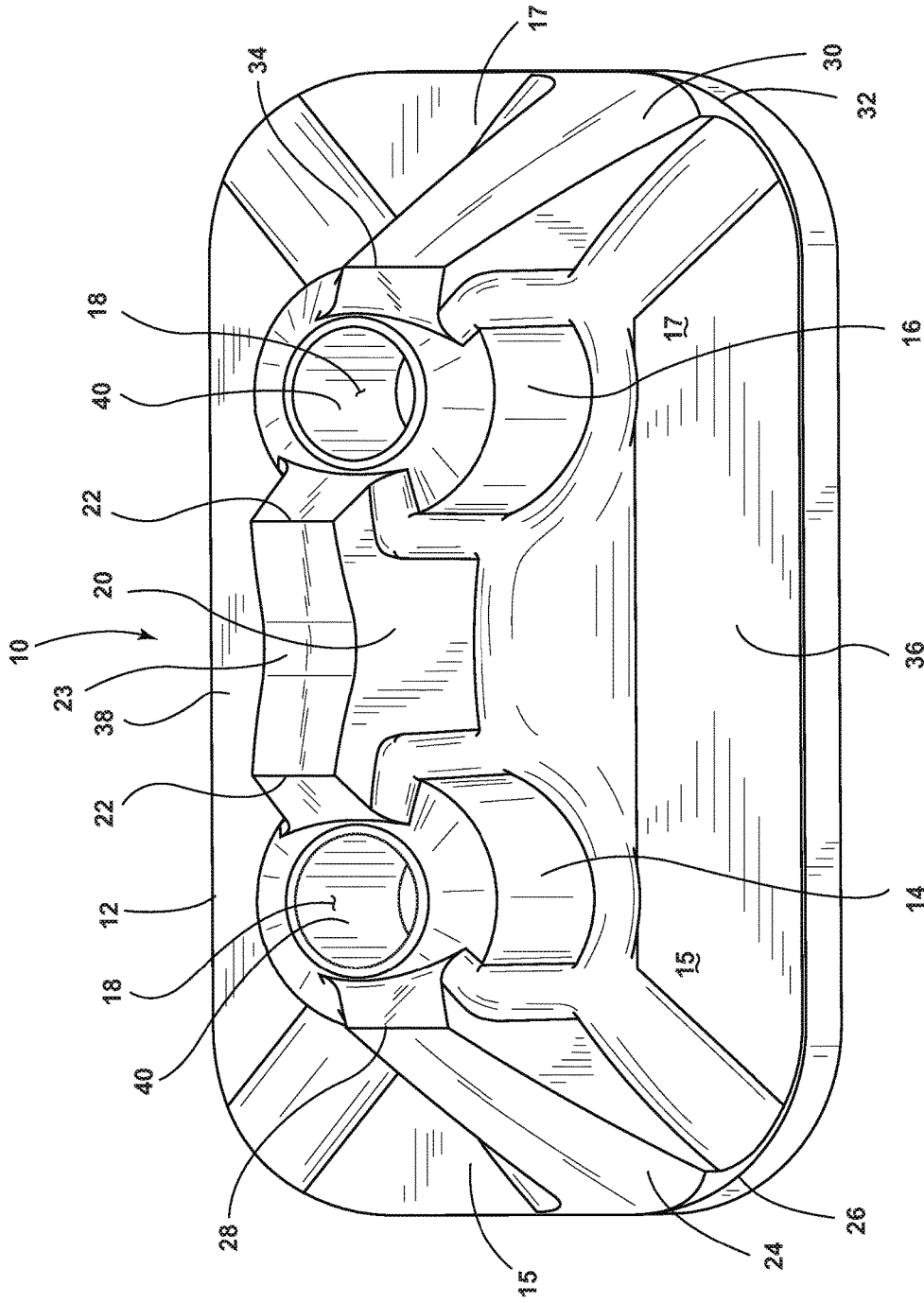

FIG. 4

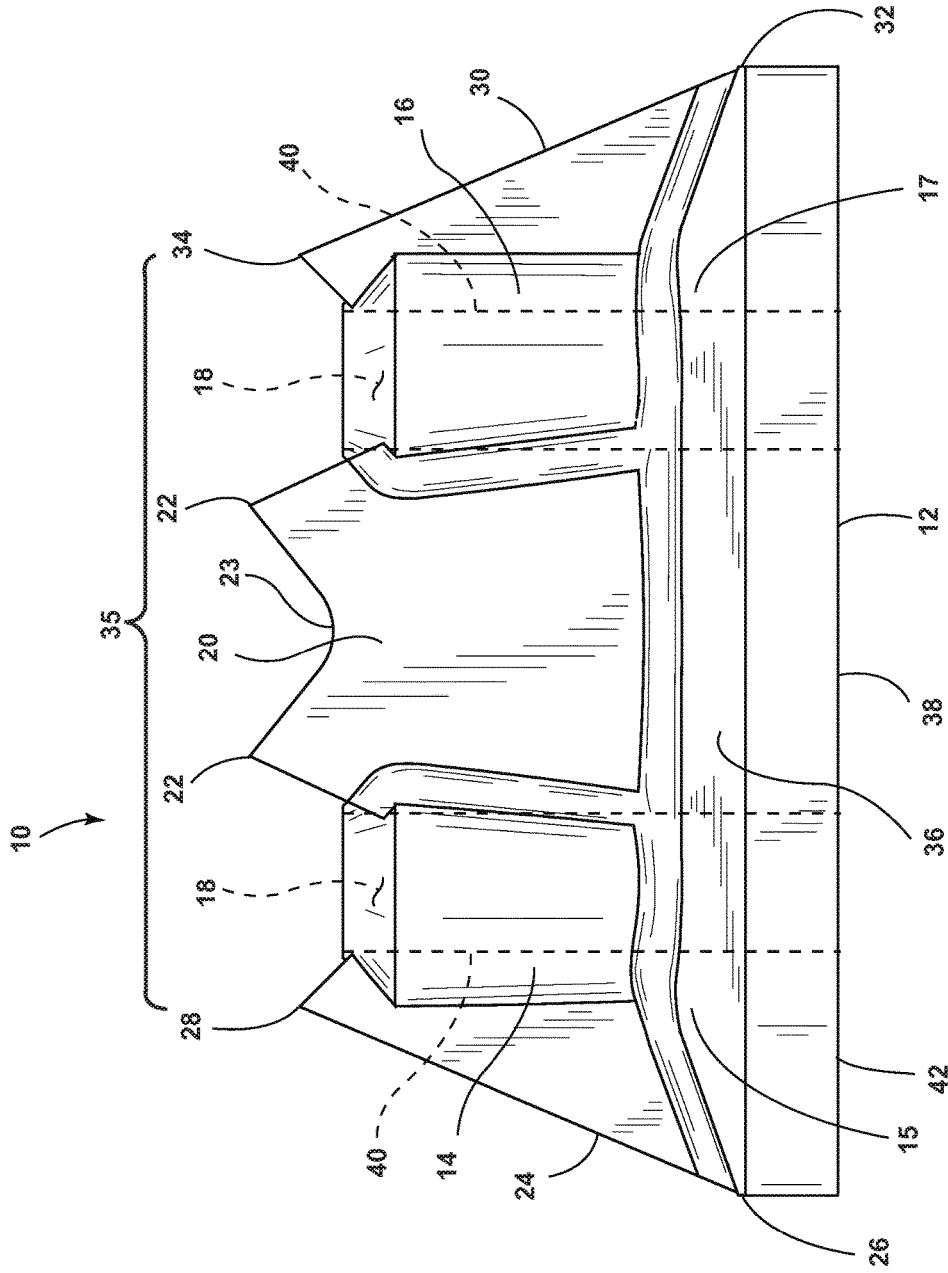

FIG. 5

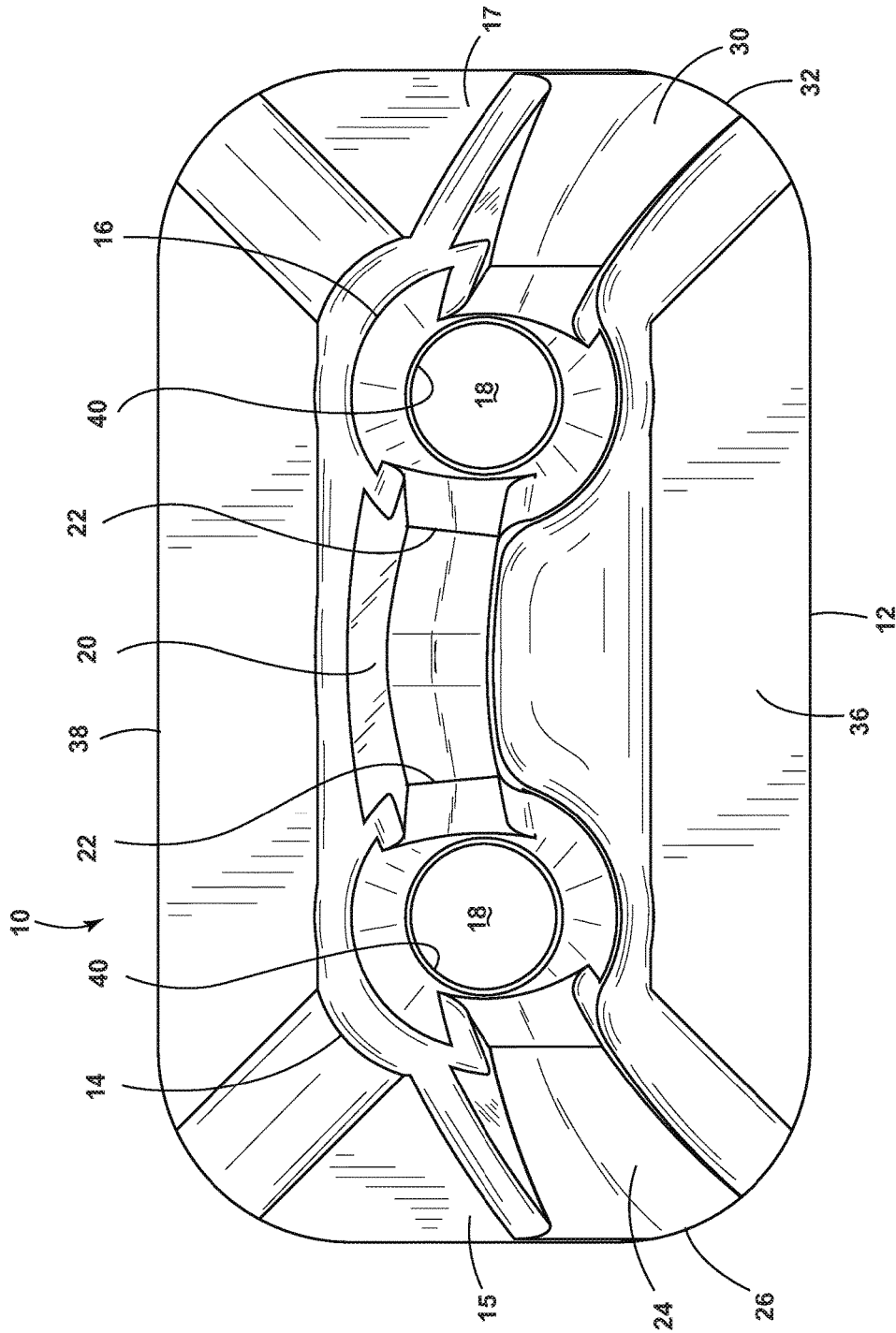

FIG. 6

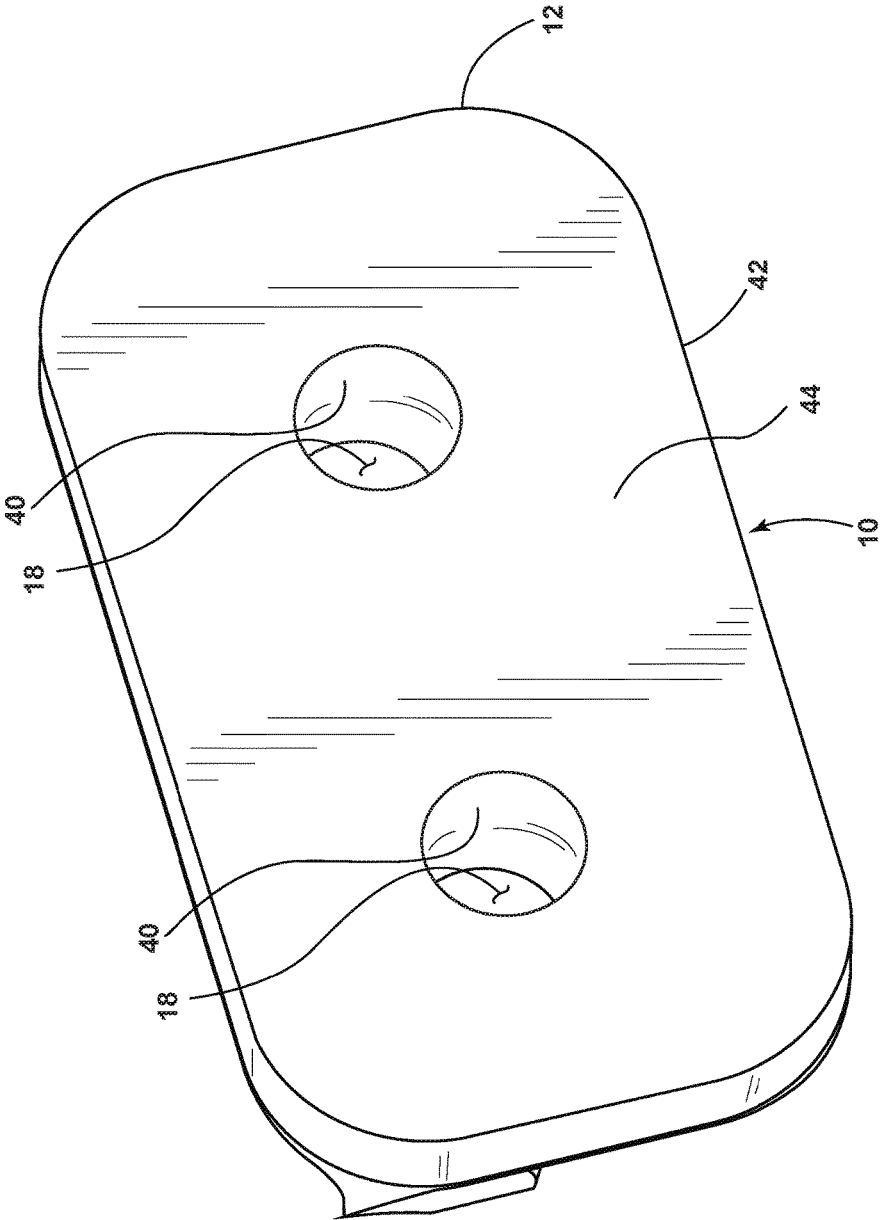

FIG. 7

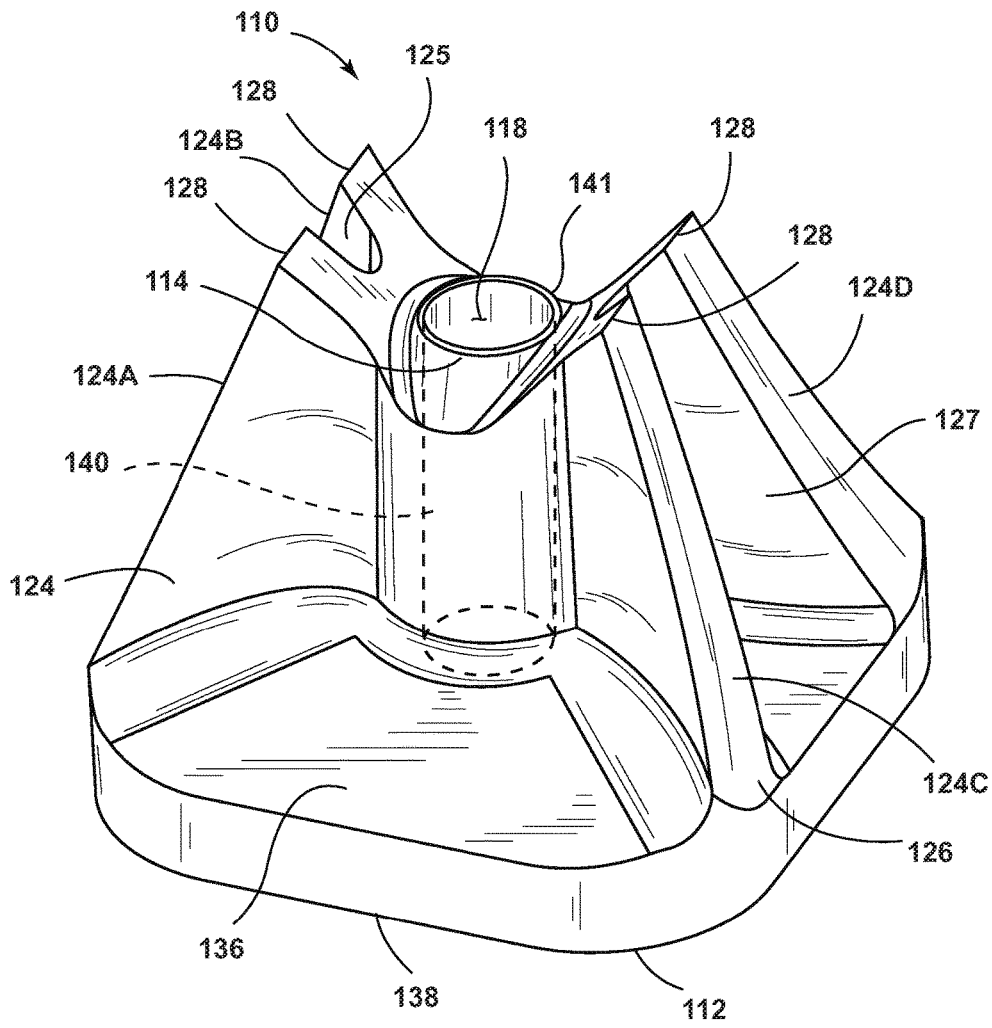

FIG. 8

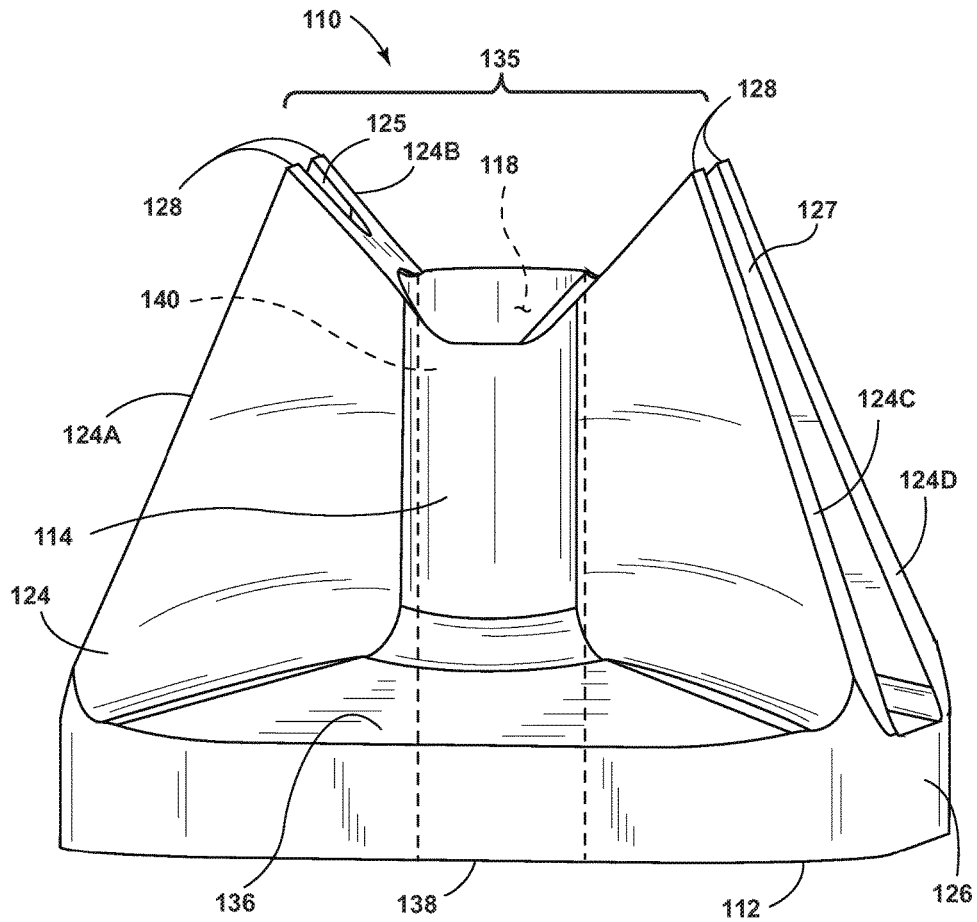

FIG. 9



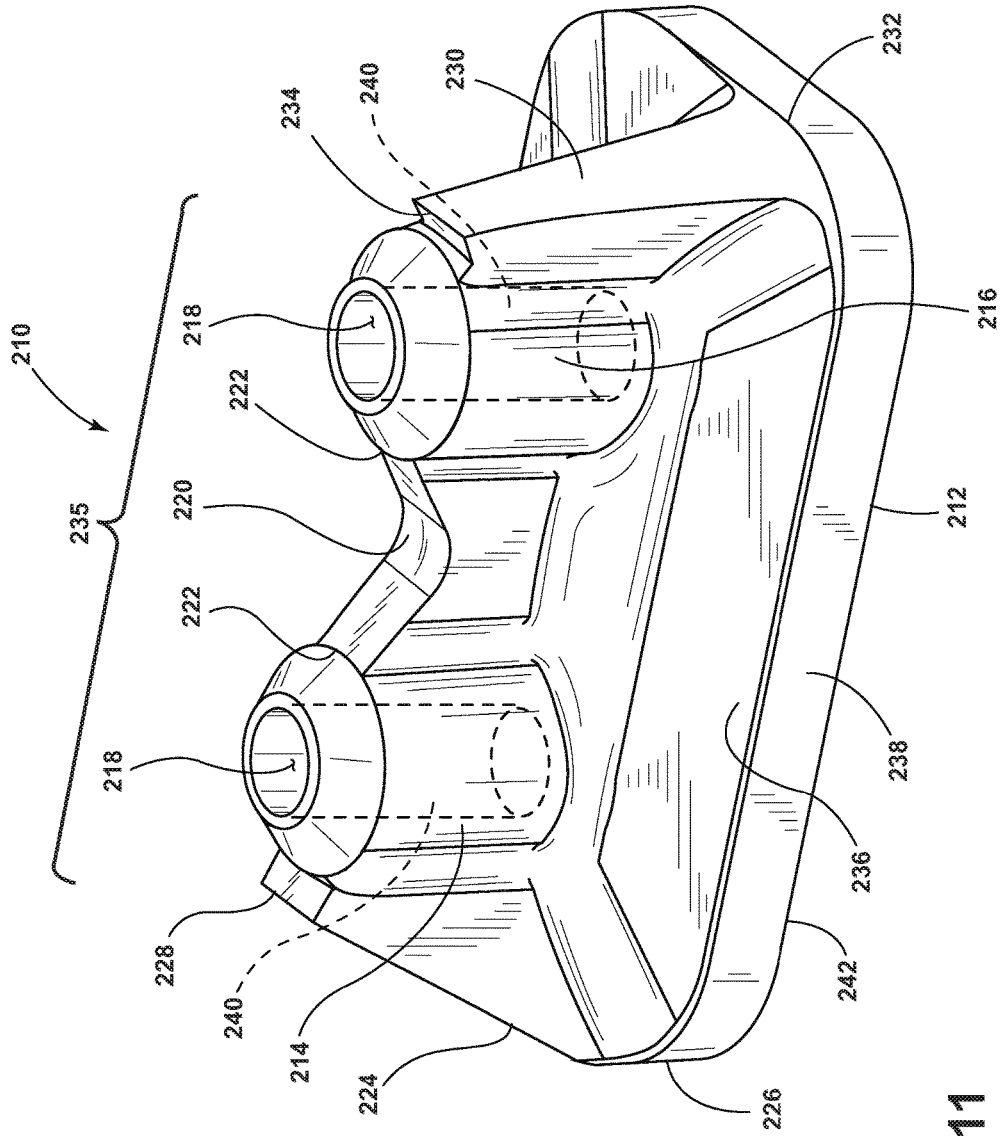

FIG. 11



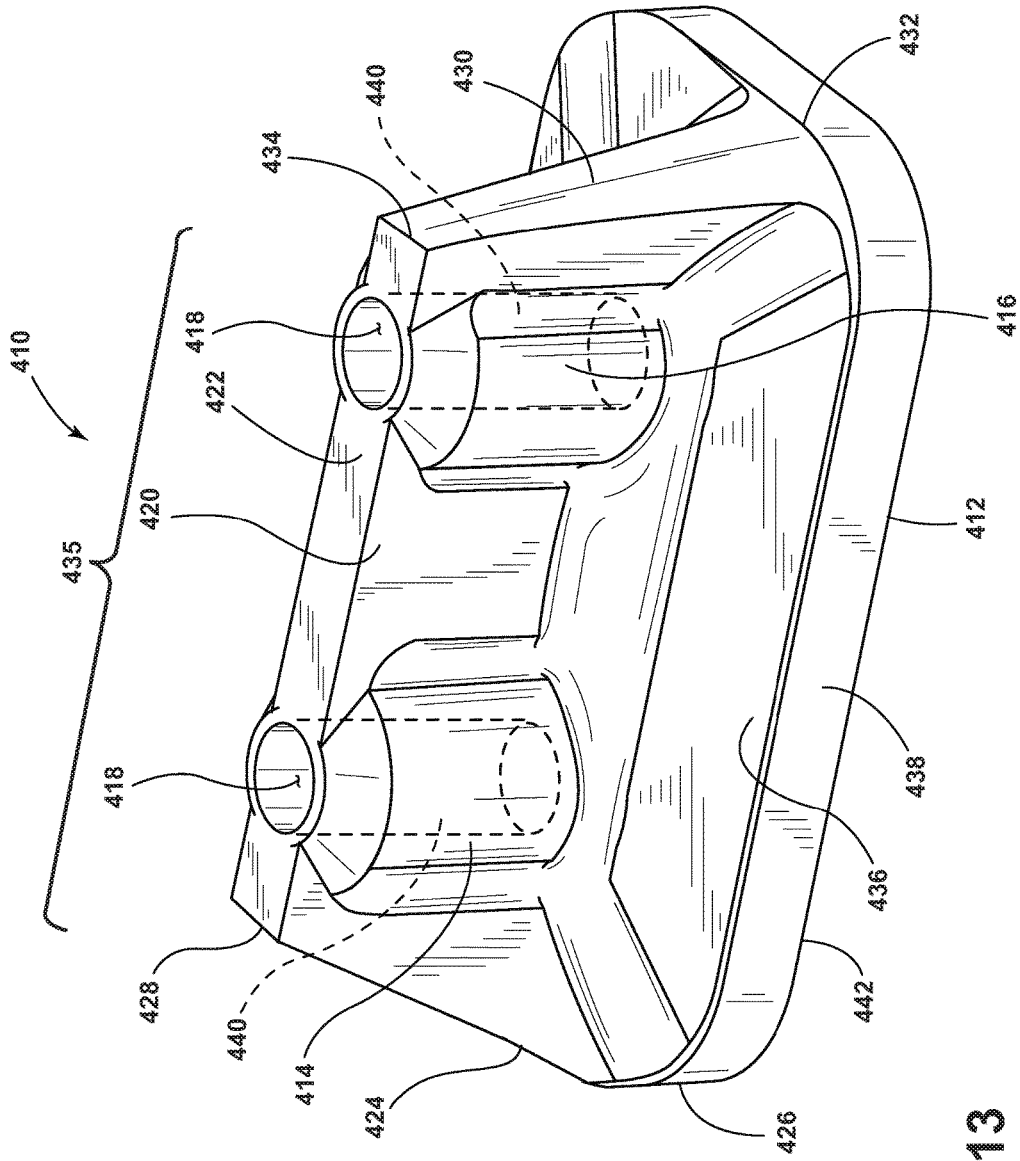

FIG. 13

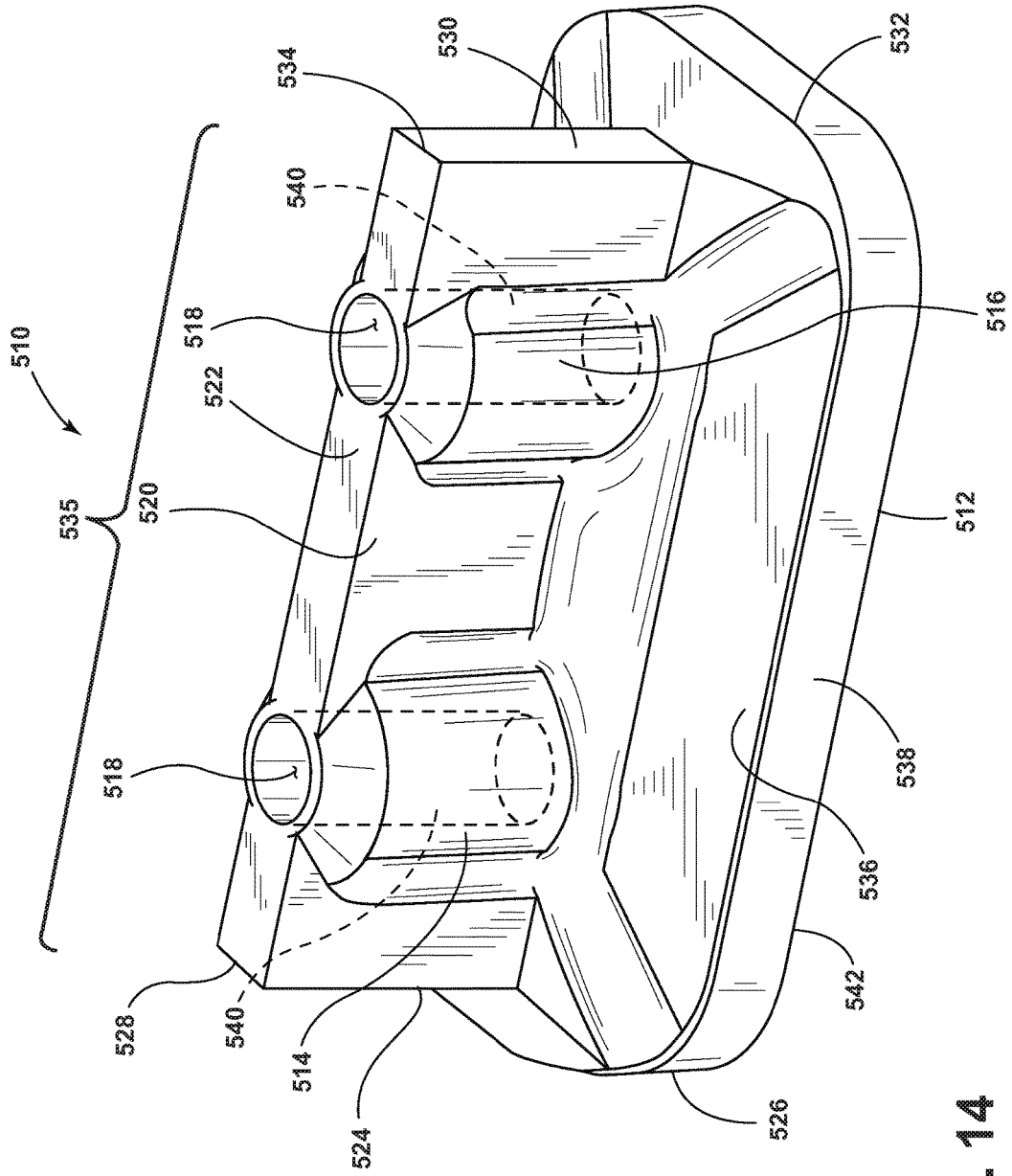

FIG. 14

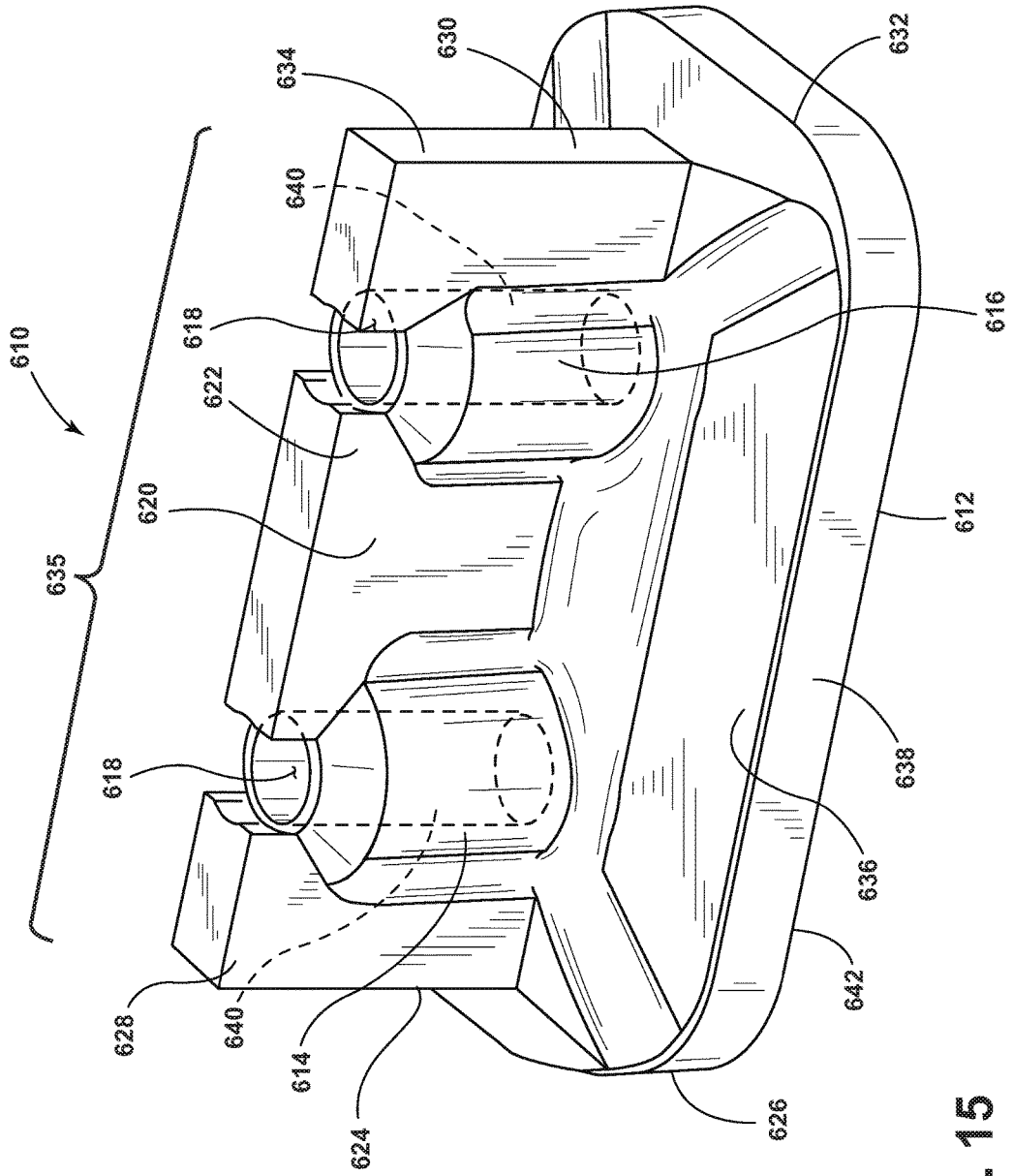

FIG. 15



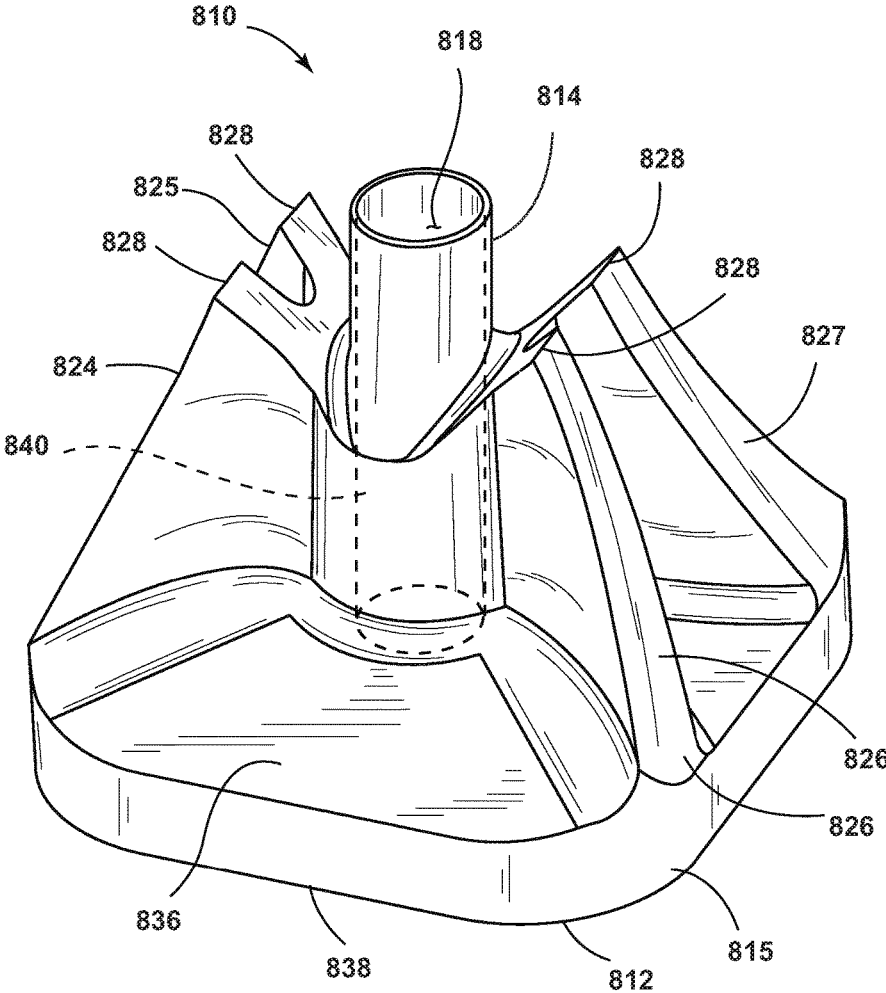

FIG. 17

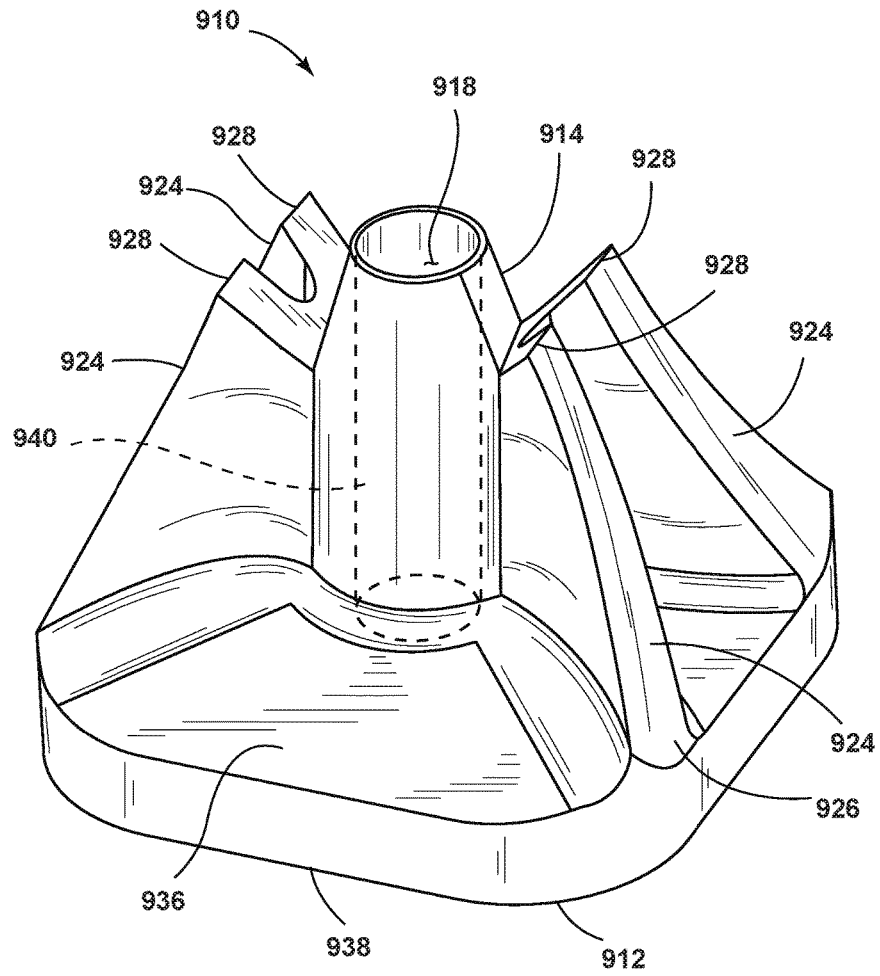

FIG. 18

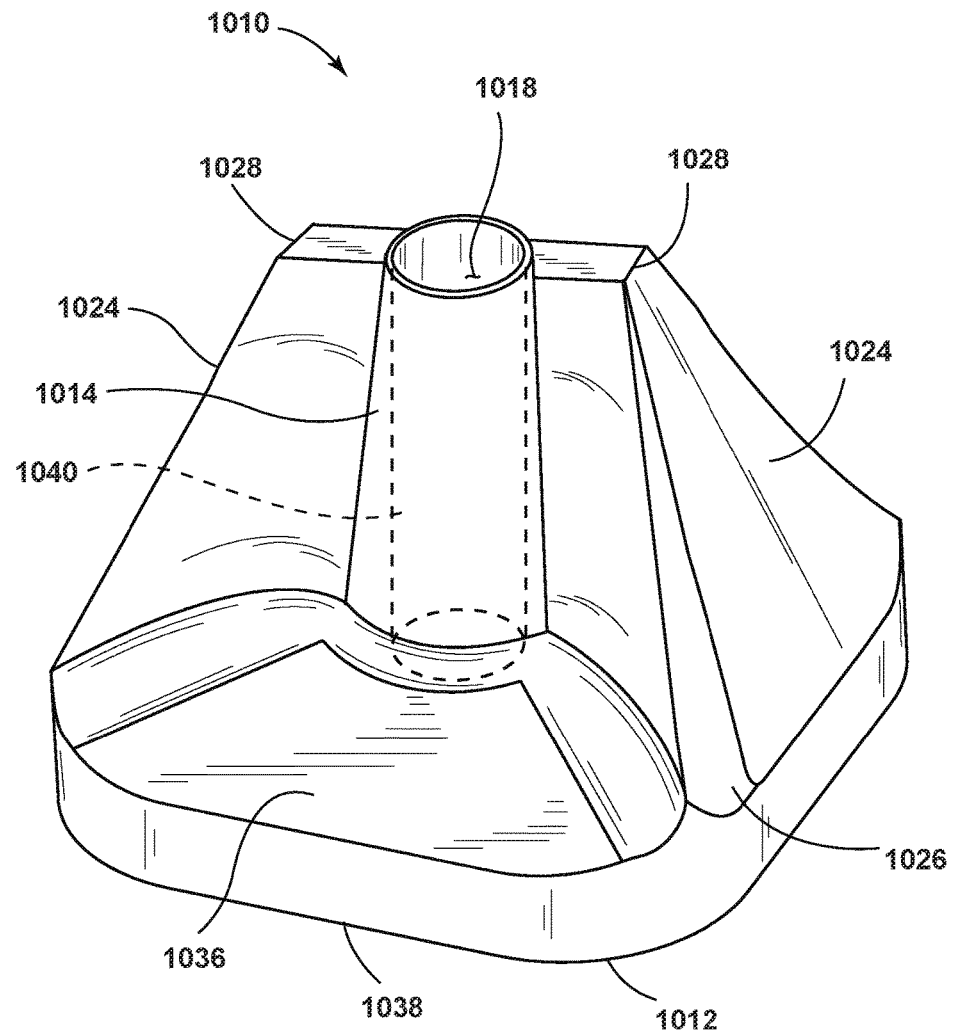

FIG. 19

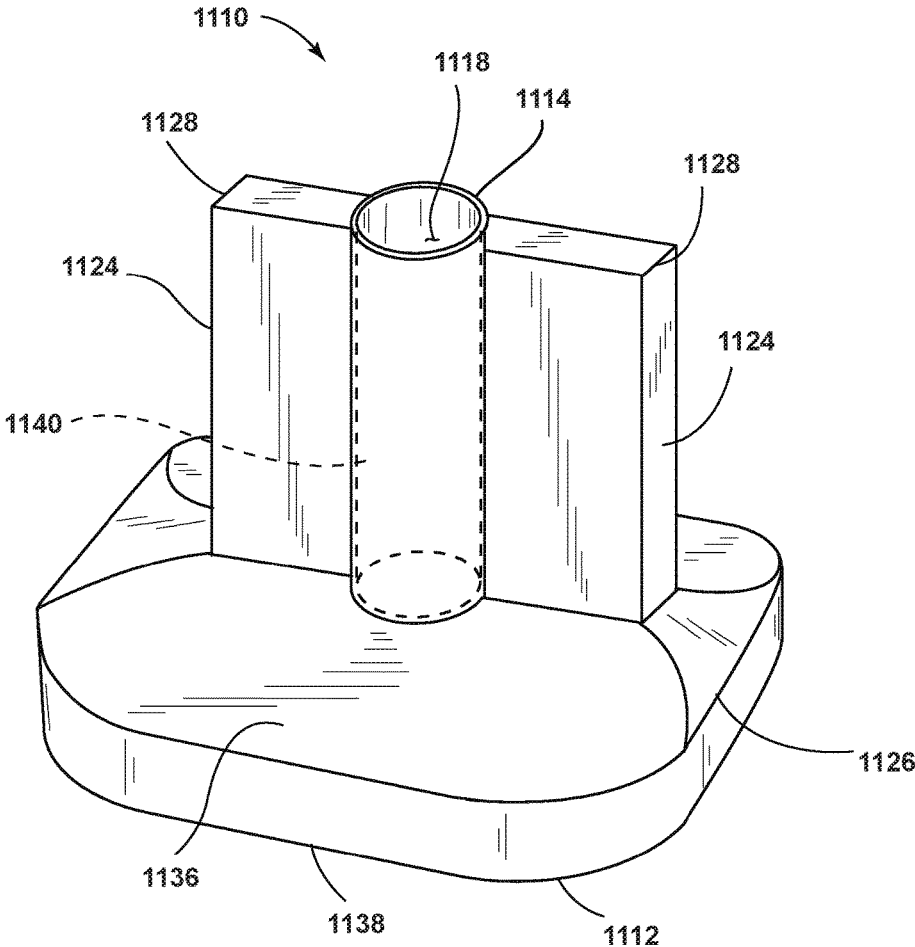

FIG. 20

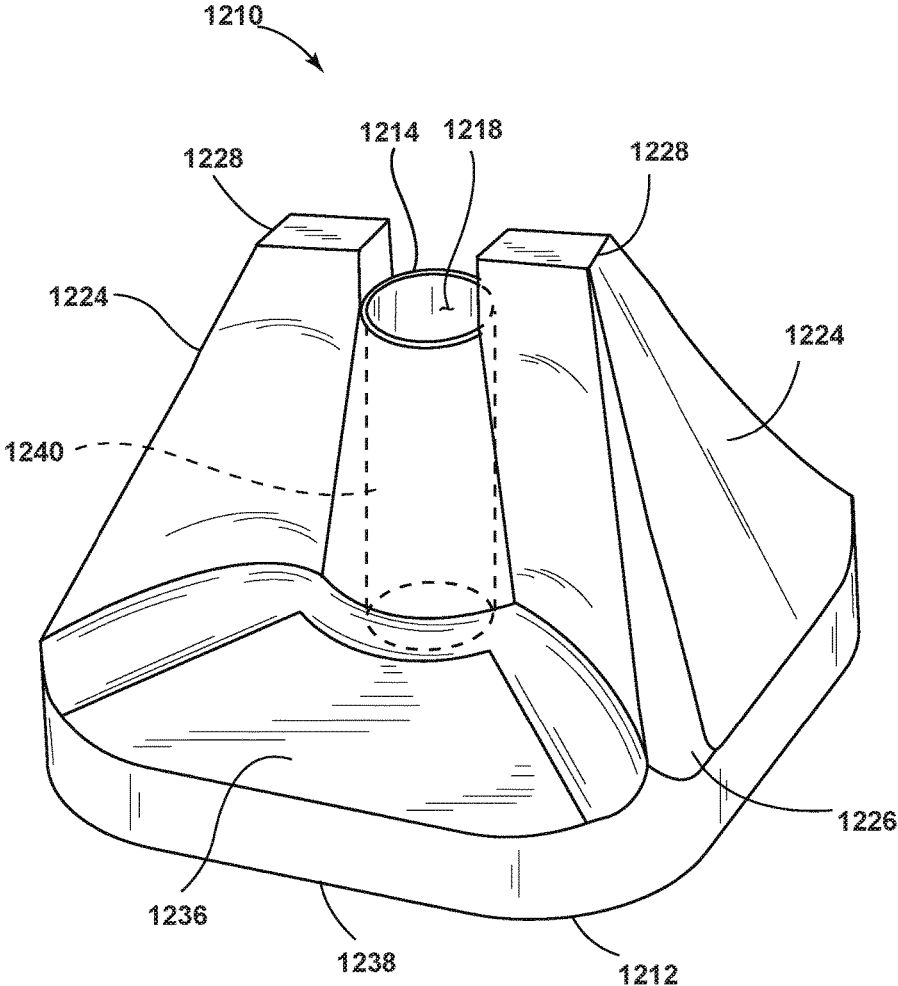

FIG. 21

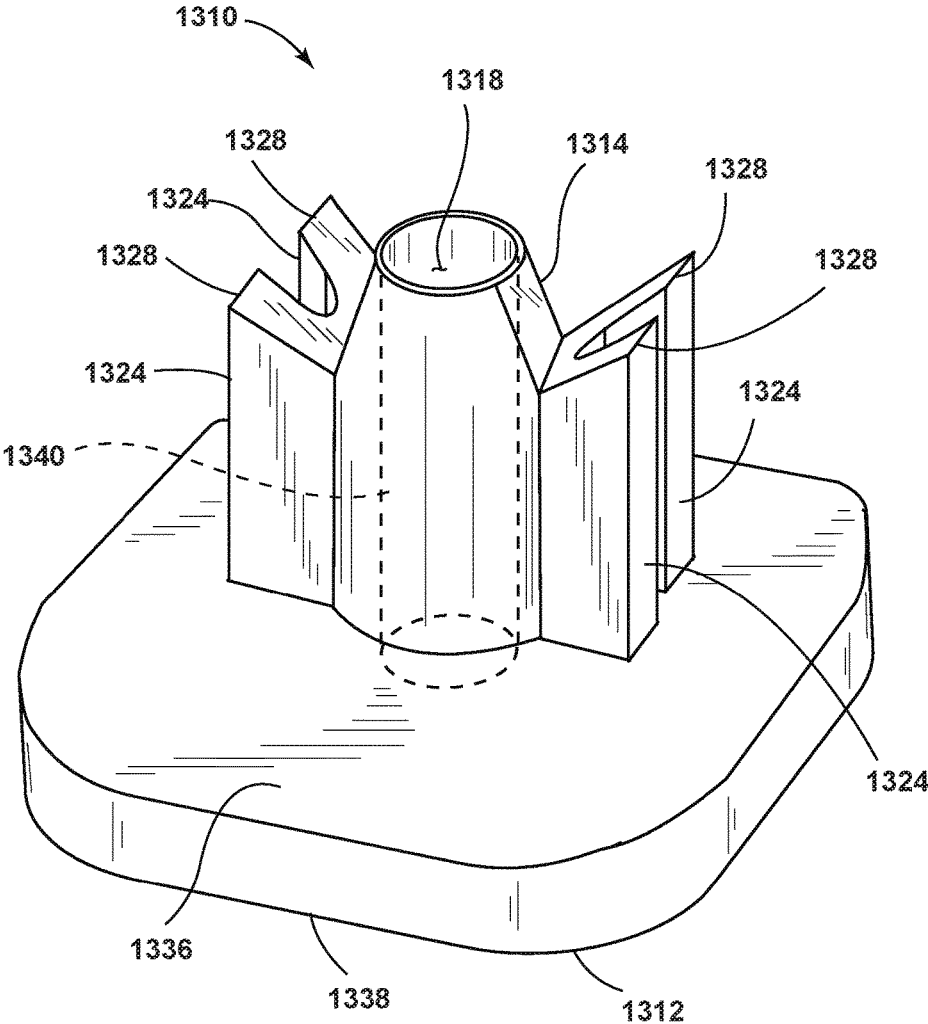

FIG. 22

1

**SNOWMOBILE TRACK STUD SUPPORT****CROSS-REFERENCE TO RELATED APPLICATIONS**

This application is a continuation of and claims priority to U.S. patent application Ser. No. 13/593,320, filed on Aug. 23, 2012, entitled "SNOWMOBILE TRACK STUD SUPPORT," now U.S. Pat. No. 9,242,685, which claims priority to and the benefit under 35 U.S.C. § 119(e) of U.S. Provisional Patent Application No. 61/527,483, filed on Aug. 25, 2011, entitled "SNOWMOBILE TRACK STUD SUPPORT," the entire disclosures of which are hereby incorporated herein by reference.

**BACKGROUND OF THE DISCLOSURE**

Typically, studs are affixed to the flexible track of a snowmobile to provide added traction. A stud is ordinarily a metal nail or pin which penetrates the snow or ice for the purpose of enhancing the vehicle's traction, thereby increasing its speed and performance. The stud is mounted through the track and through the backer plate to help stabilize the stud and to prevent the stud from pulling through the track. A mechanical fastener, such as a nut, is then used to secure the stud and backer plate to the track.

**SUMMARY OF THE PRESENT DISCLOSURE**

One aspect of the present disclosure includes a snowmobile track stud support. A base is configured to be coupled to a track of a snowmobile. A first boss extends from the base. The first boss includes a distal end having a boss aperture within which a stud can be disposed. A second boss extends from the base. The second boss includes a distal end with a boss aperture within which a stud can be disposed. A support flange extends from at least one of the first and second bosses and is disposed between the first and second bosses. The support flange includes a peak that projects away from the base. The distance from the peak to the base is greater than the distance from the distal end of the first boss to the base.

Another aspect of the present disclosure includes a snowmobile track stud support. A base is configured to be coupled to a snowmobile track. First and second bosses extend from the base. Each boss includes a distal end with a boss aperture. The first and second support flanges generally define an arcuate web configured to increase traction of the snowmobile track.

According to another aspect of the present disclosure includes a multi-piece snowmobile track stud support having a base member. A traction portion is disposed proximate the base member. The traction portion includes first and second bosses. Each boss includes a boss aperture within which a stud can be disposed. A central support flange extends between the first and second bosses. The first boss, the second boss, and the central support flange together define a web.

These and other aspects, objects, and features of the present disclosure will be understood and appreciated by those skilled in the art upon studying the following specification, claims, and appended drawings.

**BRIEF DESCRIPTION OF THE DRAWINGS**

FIG. 1 is a side view of a snowmobile having a track and a stud support of the present disclosure;

2

FIG. 2 is a side view of a stud support of the present disclosure having two studs assembled thereto;

FIG. 3 is a perspective view of a first embodiment of a stud support of the present disclosure;

FIG. 4 is a top perspective view of the stud support of FIG. 3;

FIG. 5 is a side view of the stud support of FIG. 3;

FIG. 6 is a top view of the stud support of FIG. 3;

FIG. 7 is a bottom perspective view of the stud support of FIG. 3;

FIG. 8 is a perspective view of a second embodiment of a stud support of the present disclosure;

FIG. 9 is a side view of the stud support of FIG. 8;

FIG. 10 is a top view of the stud support of FIG. 8;

FIG. 11 is a perspective view of another embodiment of a stud support of the present disclosure;

FIG. 12 is a perspective view of another embodiment of a stud support of the present disclosure;

FIG. 13 is a perspective view of another embodiment of a stud support of the present disclosure;

FIG. 14 is a perspective view of another embodiment of a stud support of the present disclosure;

FIG. 15 is a perspective view of another embodiment of a stud support of the present disclosure;

FIG. 16 is a perspective view of another embodiment of a stud support of the present disclosure;

FIG. 17 is a perspective view of another embodiment of a stud support of the present disclosure;

FIG. 18 is a perspective view of another embodiment of a stud support of the present disclosure;

FIG. 19 is a perspective view of another embodiment of a stud support of the present disclosure;

FIG. 20 is a perspective view of another embodiment of a stud support of the present disclosure;

FIG. 21 is a perspective view of another embodiment of a stud support of the present disclosure; and

FIG. 22 is a perspective view of another embodiment of a stud support of the present disclosure.

**DETAILED DESCRIPTION OF EMBODIMENTS**

For purposes of description herein, the terms "upper," "lower," "right," "left," "rear," "front," "vertical," "horizontal," and derivatives thereof shall relate to the disclosure as oriented in FIG. 3. However, it is to be understood that the disclosure may assume various alternative orientations, except where expressly specified to the contrary. It is also to be understood that the specific devices and processes illustrated in the attached drawings, and described in the following specification are simply exemplary embodiments of the inventive concepts defined in the appended claims. Hence, specific dimensions and other physical characteristics relating to the embodiments disclosed herein are not to be considered as limiting, unless the claims expressly state otherwise.

Referring to the embodiment illustrated in FIGS. 1 and 2, the reference numeral 10 generally designates a stud support designed for use with a stud 3 removably connected with a flexible track 2 of a snowmobile 1. The stud support 10 provides traction to the flexible track 2 such that the flexible track 2 can more efficiently move the snowmobile 1 over snow covered terrain.

Referring now to FIGS. 3-6, the stud support 10 includes a base 12 and first and second bosses 14, 16 which extend upward from the base 12. As clearly illustrated, the base 12 may be an elongate base (FIGS. 3-7) that includes a first end portion 15 and a second end portion 17. The first and second

bosses **14, 16** extend from first and second end portions **15, 17**, respectively. The first and second bosses **14, 16** may be cylindrical, octagonal, square, etc. It is contemplated that the first and second bosses **14, 16** may extend at an angle relative to the base **12**, such that studs **3** may be juxtapositioned at various angles. Each of the first and second bosses **14, 16** includes a distal end **41** with a boss aperture **18** within which the studs **3** may be disposed to secure the base **12** to the track **2** and a smooth bore **40** defined by a smooth cylindrical wall. Alternatively, the smooth bore **40** can have various cross-sections, such as oval, tri-oval, etc. Further, the smooth bore **40** may include a wall having various engagement surfaces, such as threads, textures, or the like. The boss aperture **18** may be replaced with a capped or overmolded member positioned over the smooth bore **40**. Further, the first and second bosses **14, 16** are spaced from one another a predetermined distance, creating a valley therebetween, and may be beveled or chamfered at the distal end **41** thereof.

A central support flange **20** is disposed between the first and second bosses **14, 16**. The central support flange **20** is in the form of a simple wall or rib and includes at least one peak **22** formed in the distal end **41** thereof. In the illustrated embodiment, the central support flange **20** includes first and second peaks **22** with the valley **23** extending therebetween. The height of the central support flange **20** is configured to be greater than the height of the first and second bosses **14, 16**, such that the peak **22** extends above the first and second bosses **14, 16**. Further, the central support flange **20** may be slightly arcuate in horizontal cross-section. In the illustrated embodiment, the stud support **10** is shown as having two peaks **22**. The arcuate construction of the central support flange **20** helps catch snow or ice, thereby providing better traction and speed to the snowmobile **1**.

A first side flange **24** extends from the first boss **14** and is positioned generally opposite the central support flange **20**, across the diameter of the first boss **14**. The first side flange **24** tapers inwardly from a first edge **26** of the base **12** to a first peak **28** adjacent the first boss **14**. Further, the first side flange **24** tapers downwardly from the first peak **28** to the boss aperture **18** disposed in the first boss **14**. The height of the first peak **28** is configured to be greater than the height of the first boss **14**, such that the first peak **28** extends above the first boss **14**.

A second side flange **30** is basically a mirror image of the first side flange **24** and tapers inwardly from a second edge **32** of the base **12** to a second peak **34** adjacent the second boss **16**. The second side flange **30** tapers downwardly from the second peak **34** to the boss aperture **18** disposed in the second boss **16**.

Additionally, in the illustrated embodiment of FIGS. 3-7, the first and second side flanges **24, 30** are slightly arcuate in horizontal cross-section, and the thicknesses of the first and second side flanges **24, 30** proximate the base **12** are greater than the thickness at the first and second peaks **28, 34**. It is also contemplated that the first boss **14**, support flange **20**, and second boss **16** may be arranged in an arcuate configuration across the base **12**.

In the example illustrated in FIGS. 3-7, the two peaks **22** of the central support flange **20** have a height greater than that of the first and second peaks **28, 34** of the first and second side flanges **24, 30**. Alternatively, the height of the two peaks **22**, the first peak **28**, and the second peak **34** may be equal. Further, the height of the two peaks **22**, the first peak **28**, and the second peak **34** may be less than the height of the first and second bosses **14, 16**. Together, the central support flange **20**, the first side flange **24**, and the second

side flange **30** define an arcuate web **35**, which enables the stud support **10** to provide additional traction for the snowmobile **1** (FIG. 1). It is contemplated that the central support flange **20** and the first and second side flanges **24, 30** can define a linearly extending web **35** across the base **12** of the stud support **10**. Further, multiple parallel or non-parallel webs **35** may extend across the base **12**. The central support flange **20** and the first and second side flanges **24, 30** provide lateral support to the base **12**, thereby preventing deflection of the base **12** during use. Accordingly, the studs **3** generally maintain a consistent orientation relative to the base **12**, thereby increasing their effectiveness and durability. Furthermore, there may be any number of bosses operably connected with the base **12**. The upper surface of the base **12** defines a tapered top wall **36** that tapers downwardly from a center portion **38** thereof to the first and second edges **26, 32**.

Referring now to FIG. 7, the lower surface of the base **12** defines a bottom wall **42**, which includes a recessed portion **44**. The recessed portion **44** is configured to maintain a relatively consistent thickness throughout the base **12** and add strength and rigidity.

Referring again to FIGS. 1 and 2, to assemble the stud support **10** to a snowmobile track **2**, a stud **3** is inserted through the backside of the track **2** and is fit into one of the first or second bosses **14, 16**. The stud **3** may be press fit, threaded, or otherwise secured inside the first and second bosses **14, 16**. The bore **40** of each of the first and second bosses **14, 16** is configured for receiving the stud **3**. The assembly process is repeated for the remaining boss.

The stud support **10** can be made of a hard plastic material, such as nylon, aluminum, carbon fiber, steel, composite, or any other suitable, lightweight, yet strong material. Further, the stud support **10** can be formed of a one piece or a multiple piece construction. The stud support **10** provides a lightweight and strong solution for supporting a traction stud **3**. Additionally, as noted above, the multiple peaks **22, 28**, and **34** provide additional traction for the snowmobile **1**.

Referring to FIGS. 8-10, a second embodiment of a single stud support **110** is designed for use with the stud **3** (FIG. 2) on the snowmobile track **2** (FIG. 2). The single stud support **110** comprises a base **112** and a boss **114**, which extends up from the base **112**. The boss **114** includes a boss aperture **118** and a bore **140**. Further, the boss **114** may be beveled or chamfered at a distal end **141** thereof.

The single stud support **110** includes a plurality of support flanges **124** (a first support flange **124A**, a second support flange **124B**, a third support flange **124C**, and a fourth support flange **124D**) which extend from the boss **114**. Each support flange **124** tapers inwardly from an edge **126** of the base **112** to a peak **128** adjacent the boss **114**. The height of the peak **128** is configured to be greater than the height of the boss **114**, such that the peaks **128** extend above the boss **114**. However, it is also contemplated that the peaks **128** could terminate at the same distance from the base **112** as the boss **114**. Additionally, the support flanges **124** may be slightly arcuate in horizontal cross-section, and the thicknesses of the support flanges **124** proximate the base **112** are greater than the thickness at the peaks **128**. A first channel **125** is defined between the first support flange **124A** and the second support flange **124B**, which taper downwardly away from the central boss **114** to a rounded peripheral edge **115** of the base **112**. A second channel **127** is defined between the third support flange **124C** and the fourth support flange **124D**, which taper downwardly away from the central boss **114**.

In the illustrated example, the single stud support **110** is shown having four unequally spaced support flanges **124**. In this configuration, the support flanges **124** are positioned in pairs on substantially opposite sides of the boss **114**. Other configurations are feasible, however, such as having the four support flanges **124** evenly spaced around the boss **114**. Together, the support flanges **124** define an arcuate web **135**, which enables the single stud support **110** to provide additional traction for the snowmobile **1**.

The single stud support **110** includes a tapered top wall **136**, a center portion **138**, a bottom wall **142**, and a recessed portion and is assembled to the snowmobile track **2** (FIG. 2) as described above. The flanges disclosed in detail above may take on a variety of shapes and constructions. For example, the flanges may have a square, rectangular, rounded, or other geometrical design conducive to increasing traction and stability.

Referring now to FIGS. 11-21, alternate embodiments of the stud support are illustrated. The subsequent embodiments are similar to the first embodiments **10** and **110**. Therefore, like parts will be identified with like numerals increased by 100, with it being understood that the description of the like parts of the first embodiments applies to the later embodiments, unless otherwise noted. In one embodiment, illustrated in FIG. 11, a height of the web **235** is less than a height of the first and second bosses **214**, **216**. In the embodiment illustrated in FIG. 12, the height of the web **335** is substantially equal to the height of the first and second bosses **314**, **316**. Additionally, the center peaks **322** have a height substantially equal to the height of the first and second peaks **328** and **334**. The embodiment illustrated in FIG. 13 also has a web **435** with a height substantially equal to the height of the first and second peaks **428** and **434**, but the web **435** has a substantially flat upper surface, instead of peaks.

Referring now to the embodiments illustrated in FIGS. 14 and 15, the stud supports **510** and **610** are shown having generally linear webs **535** and **635**, respectively; and each web **535**, **635** has a substantially flat upper surface, as opposed to peaks. The web **535** includes substantially vertical first and second side flanges **524** and **530**, and the height of the web **535** is substantially equal to the height of the first and second bosses **514**, **516**. Alternatively, the web **635** has a height greater than the height of the first and second bosses **614**, **616**. Similarly, the stud support **710**, illustrated in FIG. 16, includes multiple peaks **728**, **722**, and **734**, which form the web **735**; however, the web **735** is linear, not arcuate, as in the embodiment shown in FIG. 6, for example.

Referring now to FIGS. 17-22, alternate embodiments of the single stud support are illustrated. In the single stud support shown in FIG. 17, the support flanges **824** includes peaks **824** that have a height less than a height of the boss **814**. As clearly illustrated, the first and second support flanges **824**, **825** may be arcuate and may taper downwardly away from the central boss **814** to a rounded peripheral edge **815** of the base **812**. The first and second support flanges **824**, **825** may define a first channel **821** therebetween that extends downwardly from the central boss to the rounded peripheral edge. In addition, the third and fourth support flanges **826**, **827** may be arcuate and may taper downwardly away from the central boss **814** to the rounded peripheral edge **815** of the base **812**. The third and fourth support flanges **826**, **827** may define a second channel **823** therebetween that extends downwardly from the central boss **814** to the rounded peripheral edge **815**. Similarly, in the embodiment illustrated in FIG. 18, the peaks **924** have a height substantially equal to the height of the boss **914**. Alternately,

the support flanges **924** in the embodiment illustrated in FIG. 19 have a substantially flat upper surface, as opposed to peaks.

Referring to FIG. 20, the illustrated embodiment includes support flanges **1024** which have substantially flat upper surfaces and substantially vertical side edges. Also, the height of the support flanges **1024** is approximately equal to the height of the boss **1114**. The embodiment illustrated in FIG. 21 includes support flanges **1224** which have a substantially flat upper surface, and a height that is greater than the height of the boss **1214**. Lastly, in another embodiment, the support flanges **1324** include peaks **1328**, which are substantially equal in height to the height of the boss **1314**, and the side edges of the support flanges **1324** are substantially vertical.

It will be understood by one having ordinary skill in the art that the embodiments illustrated in the figures are examples of the stud supports, and that various combinations of the elements discussed herein could be made.

It will be understood by one having ordinary skill in the art that construction of the described disclosure and other components is not limited to any specific material. Other exemplary embodiments of the disclosure disclosed herein may be formed from a wide variety of materials, unless described otherwise herein.

For purposes of this disclosure, the term "coupled" (in all of its forms, couple, coupling, coupled, etc.) generally means the joining of two components (electrical or mechanical) directly or indirectly to one another. Such joining may be stationary in nature or movable in nature. Such joining may be achieved with the two components (electrical or mechanical) and any additional intermediate members being integrally formed as a single unitary body with one another or with the two components. Such joining may be permanent in nature or may be removable or releasable in nature unless otherwise stated.

It is also important to note that the construction and arrangement of the elements of the disclosure as shown in the exemplary embodiments is illustrative only. Although only a few embodiments of the present innovations have been described in detail in this disclosure, those skilled in the art who review this disclosure will readily appreciate that many modifications are possible (e.g., variations in sizes, dimensions, structures, shapes and proportions of the various elements, values of parameters, mounting arrangements, use of materials, colors, orientations, etc.) without materially departing from the novel teachings and advantages of the subject matter recited. For example, elements shown as integrally formed may be constructed of multiple parts or elements shown as multiple parts may be integrally formed, the operation of the interfaces may be reversed or otherwise varied, the length or width of the structures and/or members or connector or other elements of the system may be varied, the nature or number of adjustment positions provided between the elements may be varied. It should be noted that the elements and/or assemblies of the system may be constructed from any of a wide variety of materials that provide sufficient strength or durability, in any of a wide variety of colors, textures, and combinations. Accordingly, all such modifications are intended to be included within the scope of the present innovations. Other substitutions, modifications, changes, and omissions may be made in the design, operating conditions, and arrangement of the desired and other exemplary embodiments without departing from the spirit of the present innovations.

It will be understood that any described processes or steps within described processes may be combined with other

disclosed processes or steps to form structures within the scope of the present disclosure. The exemplary structures and processes disclosed herein are for illustrative purposes and are not to be construed as limiting.

It is also to be understood that variations and modifications can be made on the aforementioned structures and methods without departing from the concepts of the present disclosure, and further it is to be understood that such concepts are intended to be covered by the following claims unless these claims by their language expressly state otherwise.

What is claimed is:

1. A snowmobile track stud support comprising:
  - an elongate base configured to be removably coupled to a track of a snowmobile;
  - a first boss extending from the base, the first boss including a distal end that is tapered and which includes a boss aperture within which a first stud can be disposed to secure the base to the track;
  - a second boss extending from the base, the second boss including a distal end that is tapered and which includes a boss aperture within which a second stud can be disposed to secure the base to the track;
  - a support flange extending from and disposed between the first and second bosses, the support flange including a first peak extending upward from the first boss and a second peak extending upward from the second boss, wherein the distance from each peak to the base is greater than the distance from the distal end of the first boss to the base, and wherein the first boss, the support flange, and the second boss are arranged in an arcuate configuration across the base; and
  - a valley that extends between the first boss and the second boss.
2. The snowmobile track stud support of claim 1, wherein the first boss extends at a first angle relative to the base and the second boss extends at a second angle relative to the base.
3. The snowmobile track stud support of claim 1, wherein each peak is tapered.
4. A snowmobile track stud support comprising:
  - an elongate base configured to be removably coupled to a snowmobile track, the elongate base including a first end portion and a second end portion;
  - a first boss disposed at the first end portion and a second boss disposed at the second end portion, each boss including a distal end with a boss aperture;
  - a central support flange extending between the first and second bosses and including first and second peaks that extends past the distal end of the first and second bosses, wherein a valley is defined between the first and second peaks the valley extending from the first peak to the second peak; and
 wherein the central support flange generally defines an arcuate web configured to increase traction of the snowmobile track.
5. The snowmobile track stud support of claim 4, wherein a width of the base is greater than a width of at least one of the first and second bosses.

6. The snowmobile track stud support of claim 4, wherein a height of the central support flange is substantially equal to a height of at least one of the first and second bosses.
7. The snowmobile track stud support of claim 4, wherein a traction stud extends through the base adjacent the central support flange.
8. The snowmobile track stud support of claim 4, wherein the central support flange includes a generally arcuate construction.
9. The snowmobile track stud support of claim 4, wherein the track stud support is constructed from aluminum.
10. A multi-piece snowmobile track stud support comprising:
  - a base member; and
  - a traction portion proximate the base member, the traction portion comprising:
    - first and second bosses, each boss including a boss aperture that receives a stud that secures the base member to a snowmobile track; and
    - a central support flange extending between the first and second bosses wherein the central support flange defines a valley extending between the first boss and the second boss; and
 wherein the first boss, the second boss, and the central support flange together define an arcuate web.
11. The multi-piece snowmobile track stud support of claim 10, wherein a width of the base member is greater than a width of at least one of the first and second bosses.
12. The multi-piece snowmobile track stud support of claim 10, wherein a height of the central support flange is substantially equal to a height of at least one of the first and second bosses.
13. The multi-piece snowmobile track stud support of claim 10, wherein the central support flange includes a generally planar construction.
14. The multi-piece snowmobile track stud support of claim 10, wherein the base member and the central support flange are operably coupled together by the stud.
15. The multi-piece snowmobile track stud support of claim 10, wherein the central support flange includes a generally arcuate construction.
16. The multi-piece snowmobile track stud support of claim 10, wherein the track stud support is constructed from aluminum.
17. A snowmobile track stud support comprising:
  - a base including a rounded peripheral edge;
  - a central boss defining a boss aperture configured to receive a stud therethrough;
  - first and second arcuate support flanges tapering downwardly away from the central boss and to the rounded peripheral edge of the base defining a first channel therebetween that extends downwardly from the central boss to the rounded peripheral edge; and
  - third and fourth arcuate support flanges tapering downwardly away from the central boss and to the rounded peripheral edge of the base defining a second channel therebetween that extends downwardly from the central boss to the rounded peripheral edge.

\* \* \* \* \*