



(19) **United States**

(12) **Patent Application Publication**

**Eck et al.**

(10) **Pub. No.: US 2019/0040942 A1**

(43) **Pub. Date: Feb. 7, 2019**

(54) **LAUNCH ASSIST MECHANISM FOR A CONTINUOUSLY VARIABLE TRANSMISSION**

(52) **U.S. Cl.**  
CPC ..... *F16H 55/563* (2013.01); *F16H 61/66236* (2013.01); *F16H 61/662* (2013.01); *F16H 59/24* (2013.01); *F16H 2061/66213* (2013.01); *F16H 2312/02* (2013.01); *F16H 9/18* (2013.01)

(71) Applicant: **TEAM Industries, Inc.**, Bagley, MN (US)

(72) Inventors: **Brian George Eck**, Bagley, MN (US); **Brandon R. Bonham**, Bagley, MN (US)

(57) **ABSTRACT**

(73) Assignee: **TEAM Industries, Inc.**, Bagley, MN (US)

(21) Appl. No.: **16/057,404**

(22) Filed: **Aug. 7, 2018**

**Related U.S. Application Data**

(60) Provisional application No. 62/542,005, filed on Aug. 7, 2017.

**Publication Classification**

(51) **Int. Cl.**  
*F16H 55/56* (2006.01)  
*F16H 61/662* (2006.01)  
*F16H 9/18* (2006.01)

A primary clutch of a continuously variable transmission with a launch mechanism is provided. The primary clutch includes a central post, a fixed sheave assembly, a movable sheave assembly and a locking mechanism. The central post is configured to receive rotational torque from a motor. The fixed sheave assembly is statically mounted on the central post. The movable sheave assembly is mounted on the central post. The movable sheave assembly includes a movable sheave system that is configured to move axially on the central post towards the fixed sheave assembly as RPM of the primary clutch increase. The locking mechanism is configured and arranged to selectively prevent movement of the movable sheave system independent of the RPM of the primary clutch.

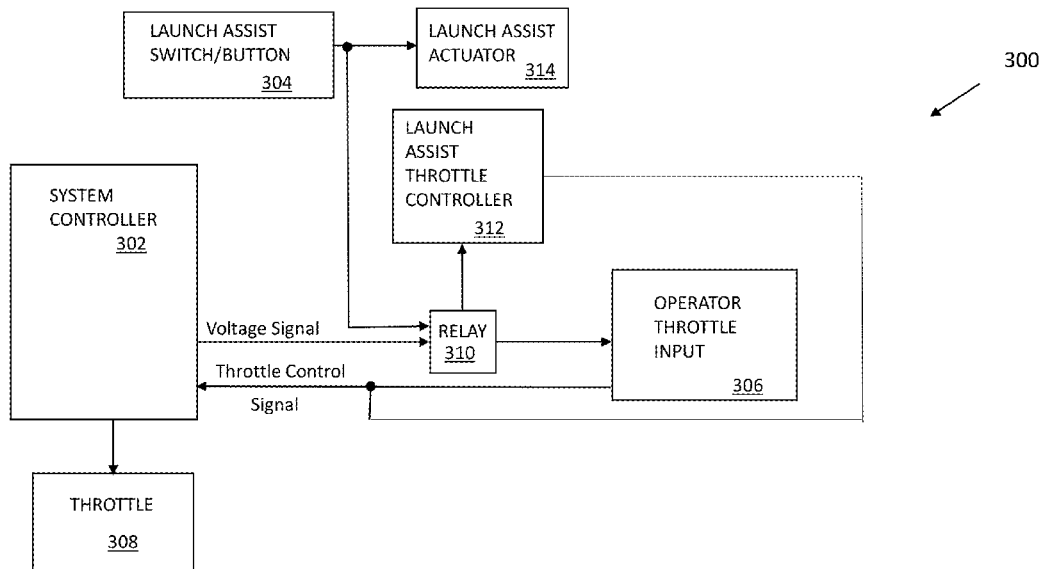

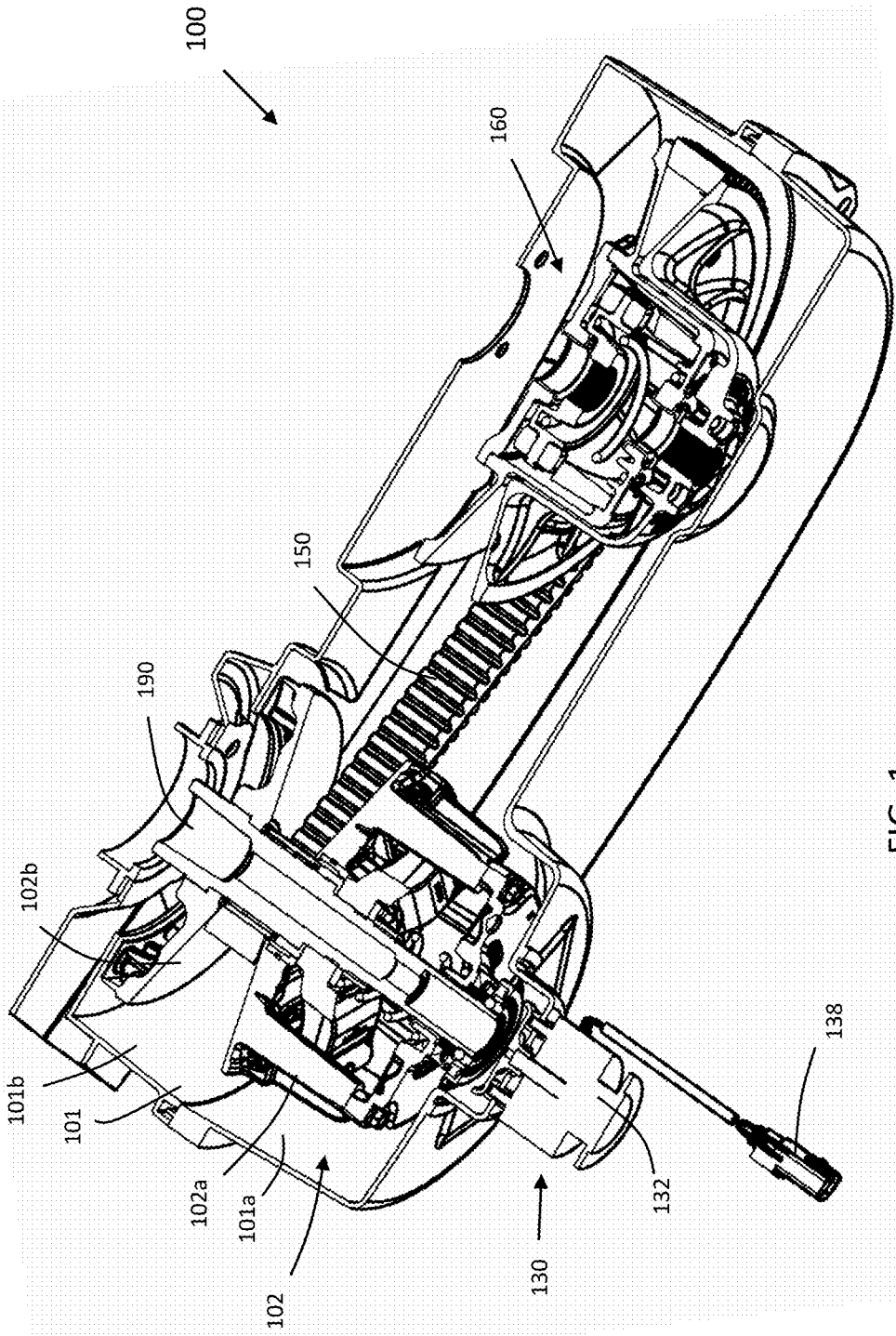

FIG. 1

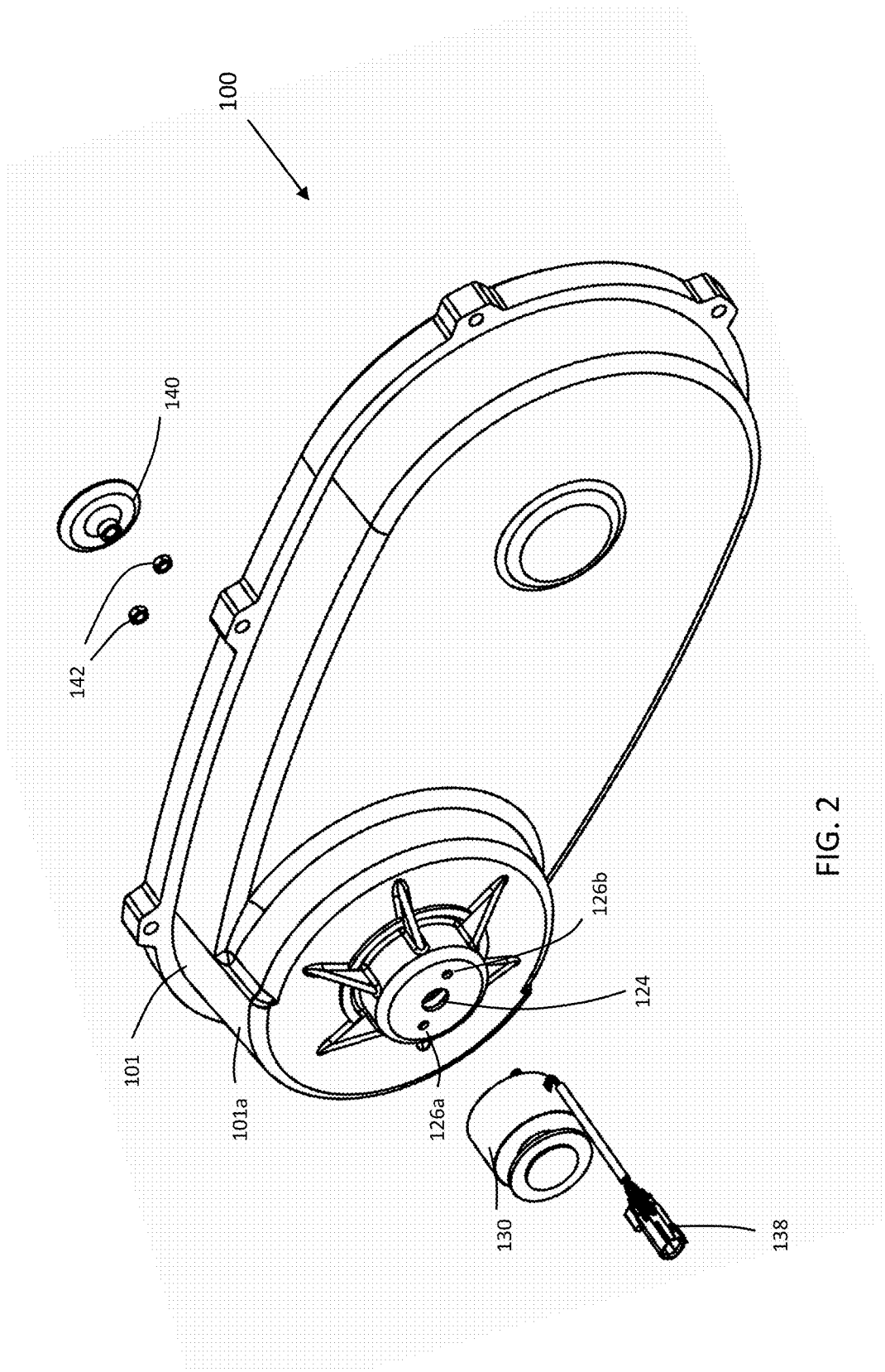

FIG. 2

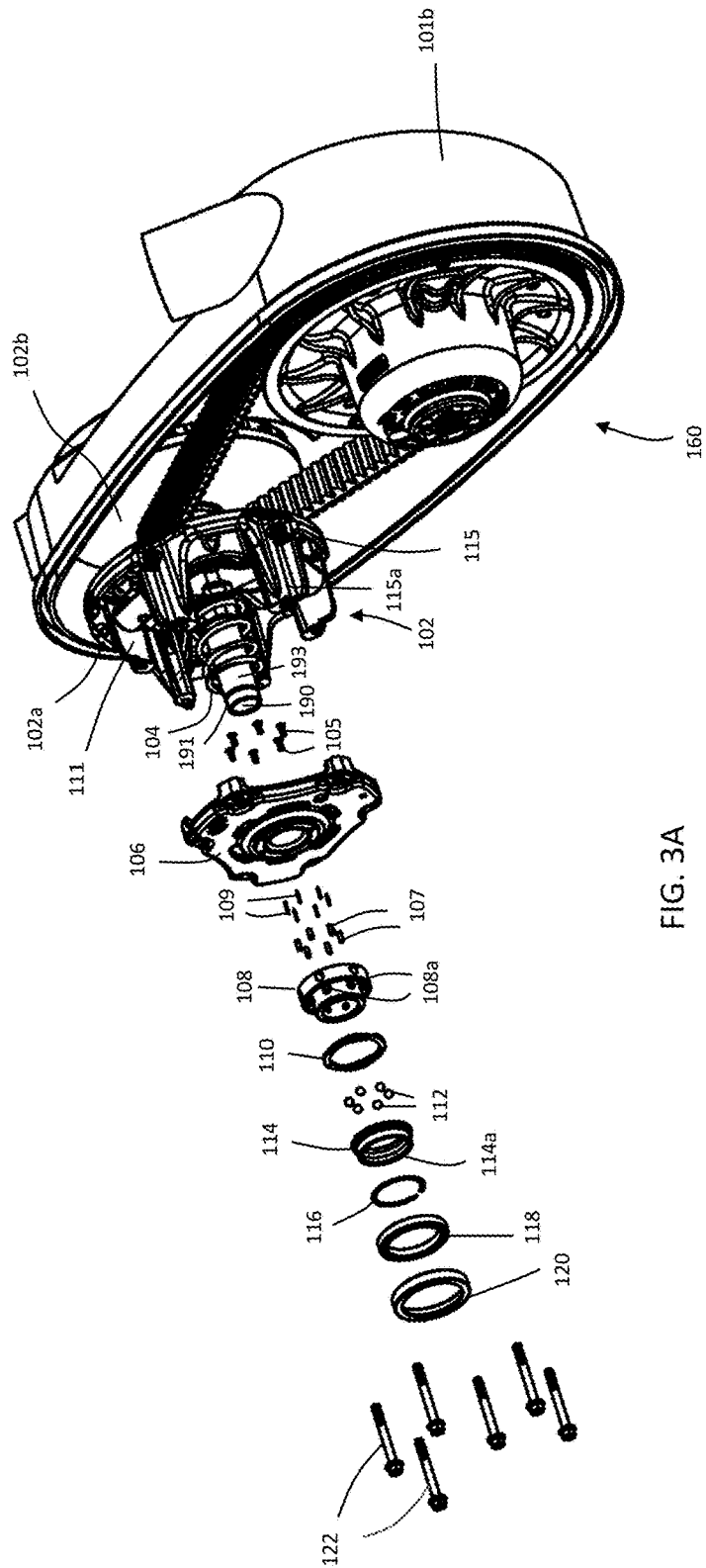

FIG. 3A

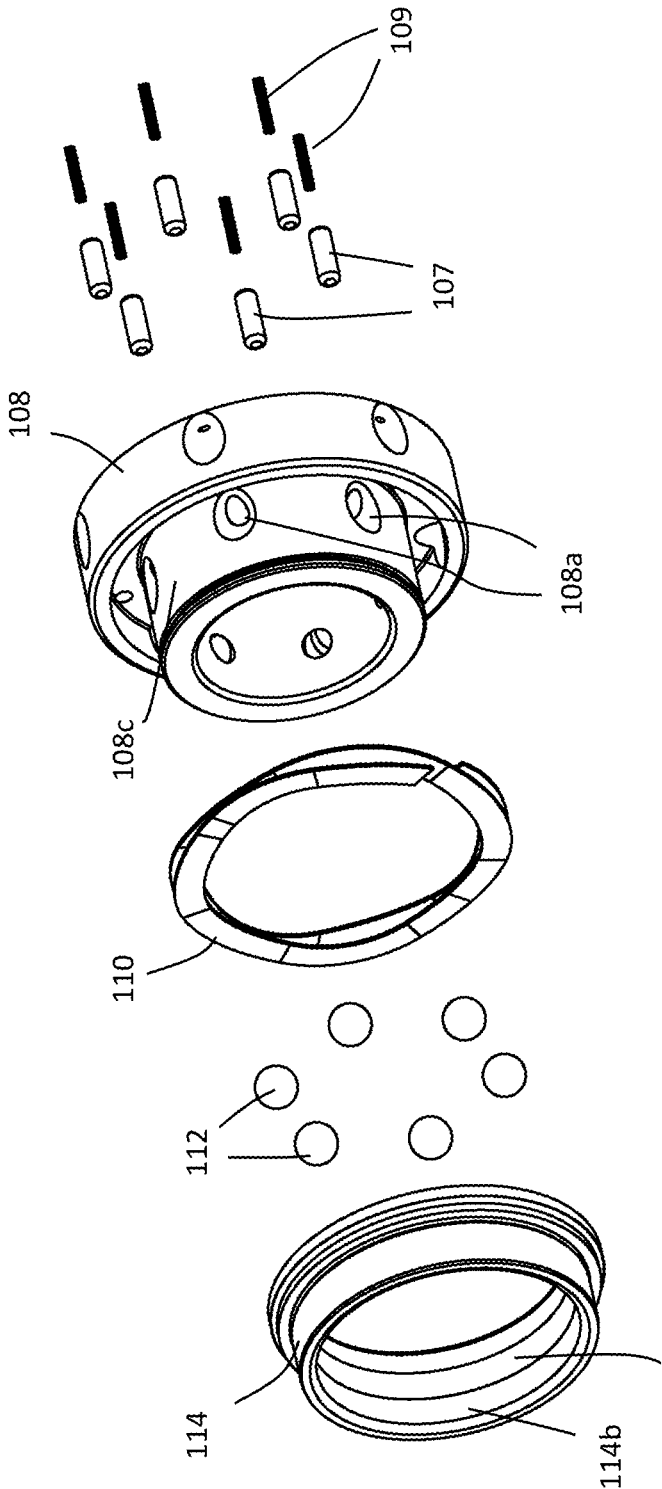

FIG. 3B

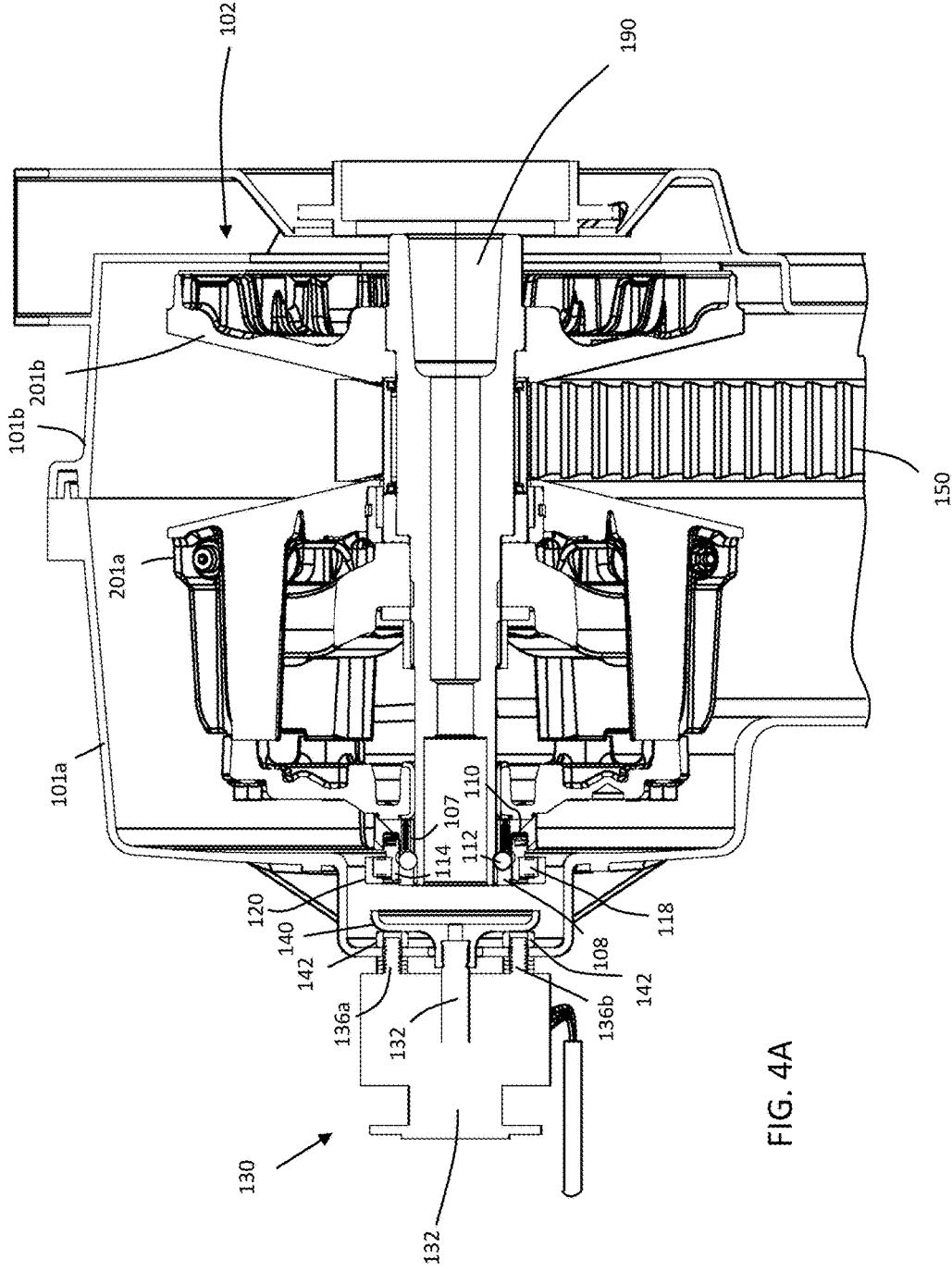

FIG. 4A

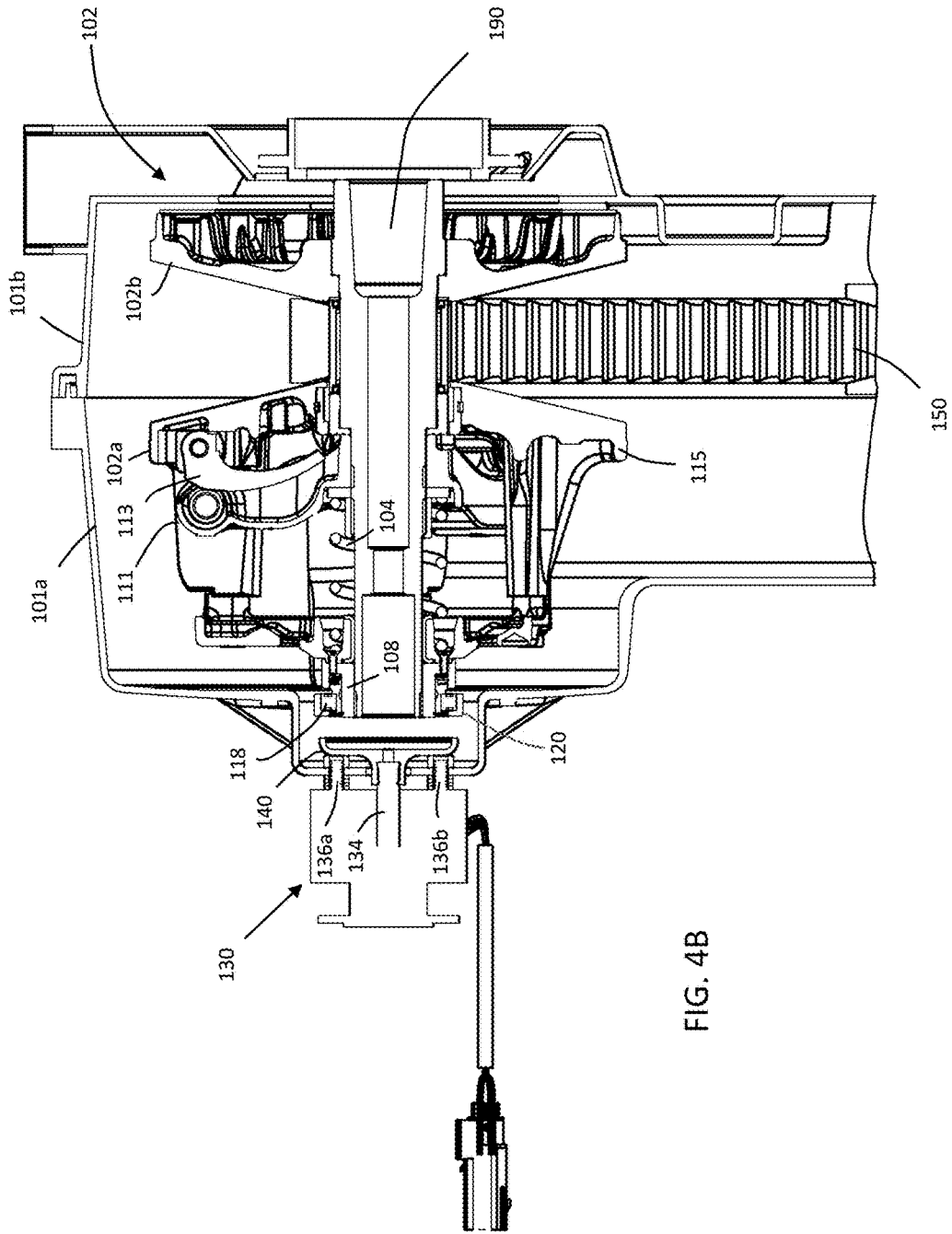

FIG. 4B

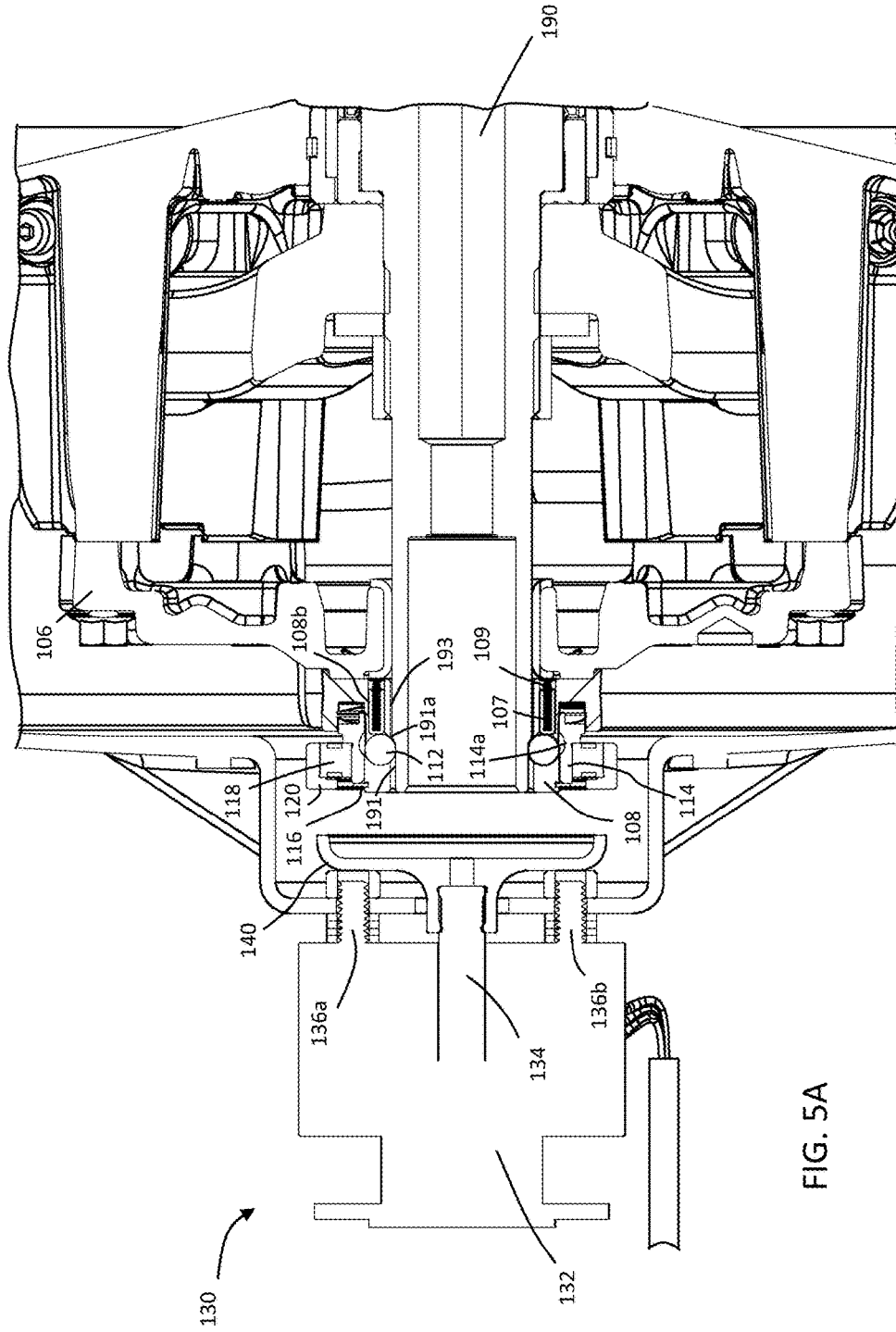

FIG. 5A

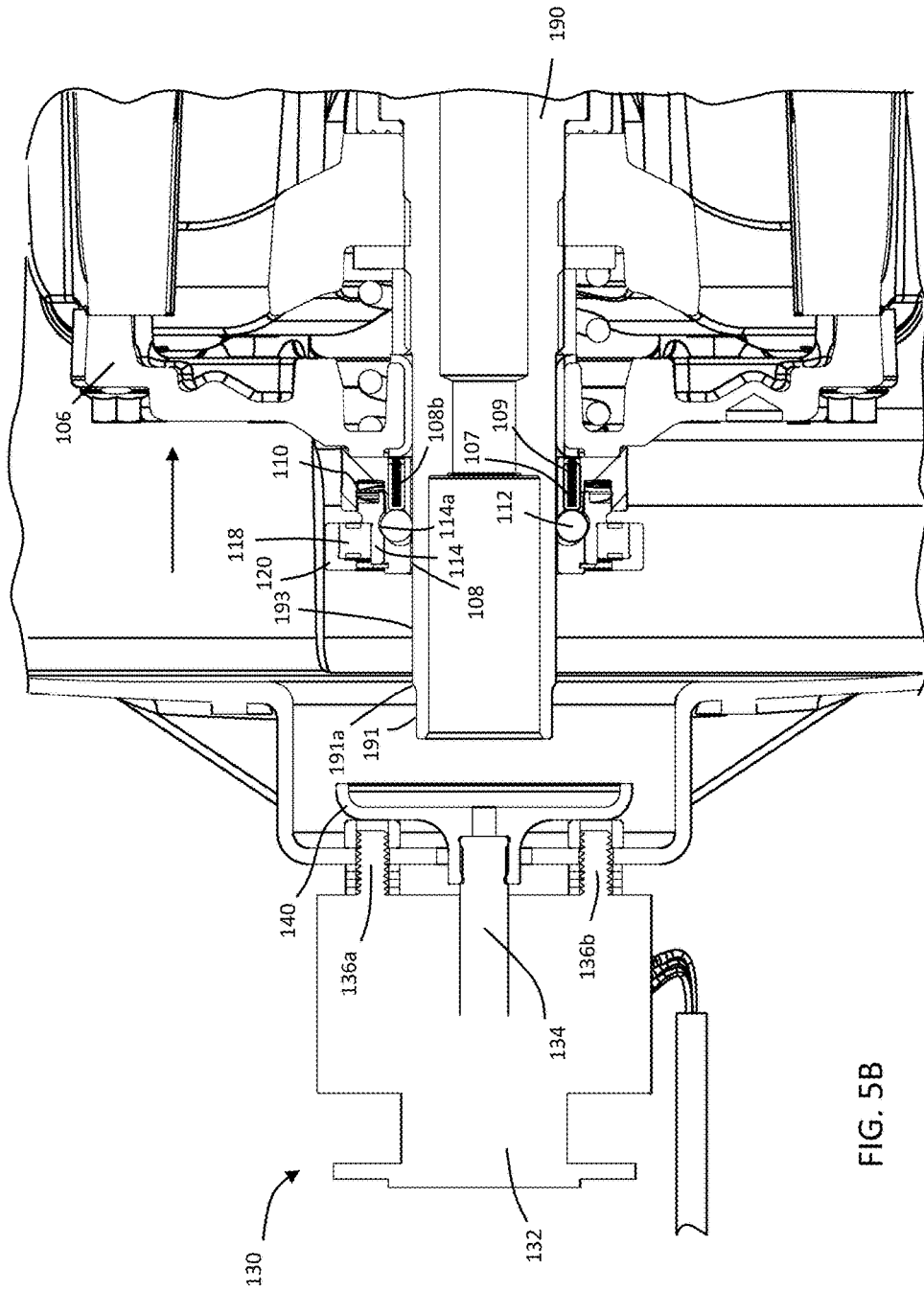

FIG. 5B

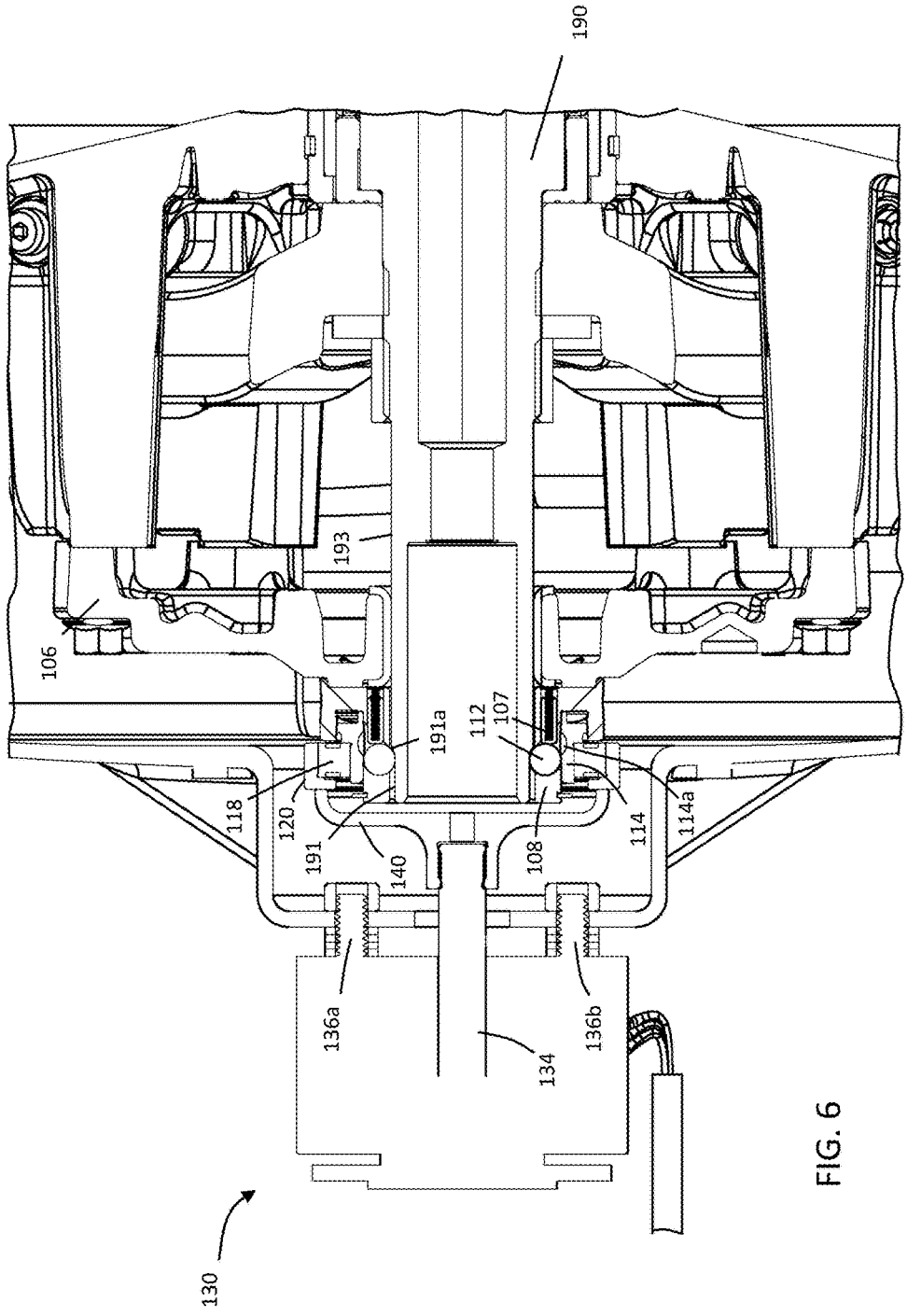

FIG. 6

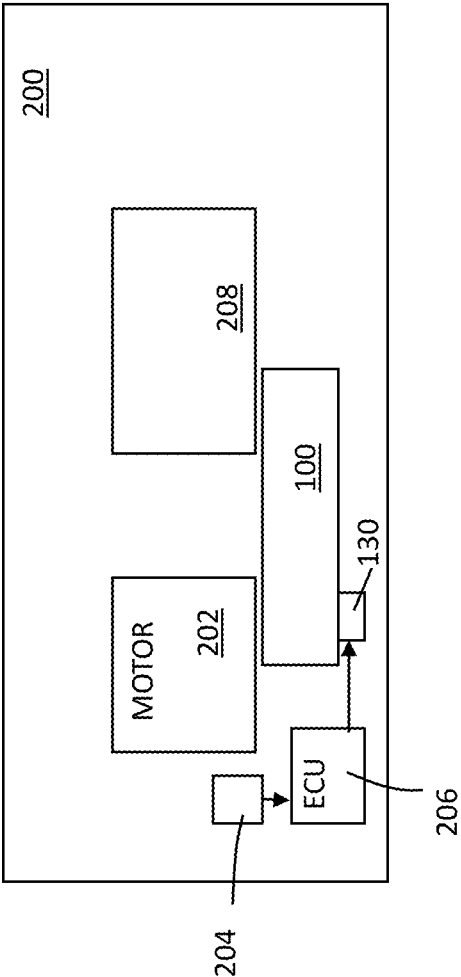

FIG. 7

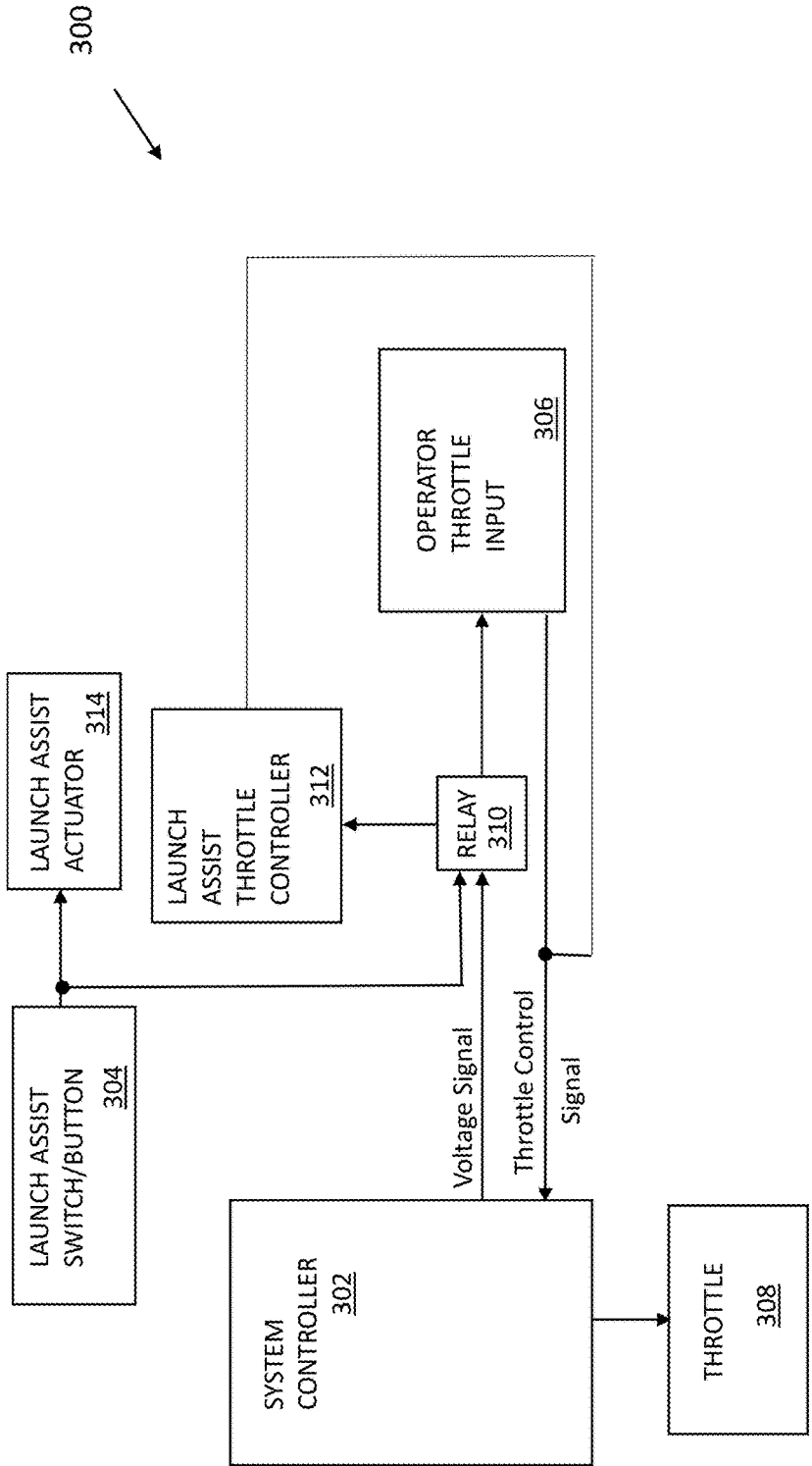

FIG. 8

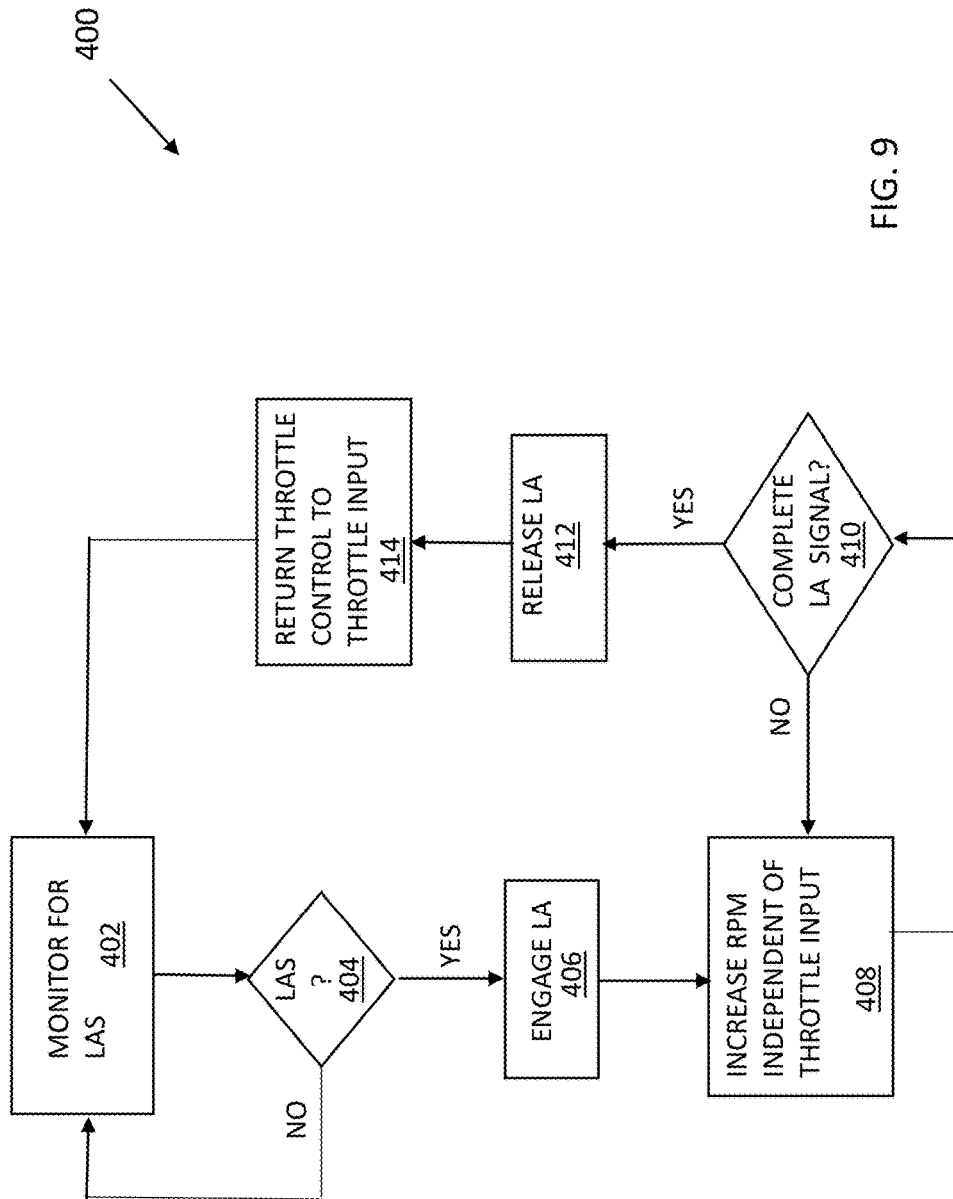

FIG. 9

## LAUNCH ASSIST MECHANISM FOR A CONTINUOUSLY VARIABLE TRANSMISSION

### CROSS-REFERENCE TO RELATED APPLICATIONS

[0001] This Application claims priority to U.S. Provisional Application Ser. No. 62/542,005, entitled "Launch Assist Mechanism for a CVT," filed on Aug. 7, 2017, which is incorporated in its entirety herein by reference.

### BACKGROUND

[0002] In a Continuously Variable Transmission (CVT) a belt transfers rotational torque from a drive clutch (primary clutch) to a driven clutch (secondary clutch). The primary clutch is typically in rotational communication with a crankshaft of an engine. The secondary clutch provides torque to at least a drive train of a vehicle. As the engine's revolutions per minute (RPMs) increase, a movable sheave that makes up part of the primary clutch moves towards a fixed sheave of the primary clutch pinching the belt to transfer rotational torque to the secondary clutch. Moreover, as the moveable sheave comes closer still to the fixed sheave, the belt moves away from a rotational axis of the primary clutch. This movement of the belt away from the rotational axis at least in part changes the gear ratio of the CVT. Hence a consistent RPM launch profile is provided in a typical CVT that is based at least in part on the RPM of the primary clutch and the operating characteristics of flyweights and a main biasing member.

### SUMMARY

[0003] The present invention will be understood by reading and studying the following specification. The following summary is made by way of example and not by way of limitation. It is merely provided to aid the reader in understanding some of the aspects of the subject matter described. Embodiments provides a launch assist mechanism for a CVT that allows a vehicle operator to selectively override when a primary clutch engages (pinches) the belt to launch the vehicle at a desired RPM.

[0004] In one example embodiment, a primary clutch of a continuously variable transmission with a launch assist mechanism is provided. The primary clutch includes a central post, a fixed sheave assembly, a movable sheave assembly and a locking mechanism. The central post is configured to receive rotational torque from a motor. The fixed sheave assembly is statically mounted on the central post. The movable sheave assembly is mounted on the central post. The movable sheave assembly includes a movable sheave system that is configured to move axially on the central post towards the fixed sheave assembly as RPM of the primary clutch increase. The locking mechanism is configured and arranged to selectively prevent movement of the movable sheave system independent of the RPM of the primary clutch.

[0005] In another example, another primary clutch of a continuously variable transmission with a launch assist mechanism provided. The primary clutch includes a central post, a fixed sheave assembly and a movable sheave assembly. The central post is configured to receive rotational torque from a motor. The fixed sheave assembly is statically mounted on the central post. The movable sheave assembly

is mounted on the central post. The movable sheave assembly includes a spider, a movable base, a primary clutch cover, a main biasing member and at least one flyweight. The spider is statically mounted to the central post. The primary clutch cover is coupled to the movable base. The main biasing member is positioned to assert a main biasing force to distance the primary clutch cover from the spider. Moreover, the least one flyweight forms a flyweight-main biasing member configuration to selectively move at least portion of the movable sheave assembly axially on the central post. The at least one flyweight pivotally coupled to the movable base. The at least one flyweight configured and arranged to engage the spider as RPM of the primary clutch increases to assert a force that counters the main biasing force of the main biasing member to move the primary clutch cover and movable base axially towards the fixed sheave assembly along the central post. Further a locking mechanism is included that is configured and arranged to selectively prevent movement of the primary clutch cover and movable base independent of the flyweight-main biasing member configuration.

[0006] In yet another example, a vehicle with a launch assist mechanism is provided. The vehicle includes an engine to generate torque, a continuously variable transmission and drive train. The continuously variable transmission includes a primary clutch and a secondary clutch. The secondary clutch is rotationally coupled to the primary clutch via endless looped belt. The primary clutch includes a central post, a fixed sheave assembly, a movable sheave assembly and a locking mechanism. The central post is configured to receive rotational torque from the motor. The fixed sheave assembly is statically mounted on the central post. The movable sheave assembly is mounted on the central post. The movable sheave assembly includes a movable sheave system that is configured to move axially on the central post towards the fixed sheave assembly as RPM of the primary clutch increases. The locking mechanism is configured and arranged to selectively prevent movement of the movable sheave system independent of RPM of the primary clutch. The drive train is coupled to the secondary clutch.

[0007] In still further an embodiment, a method of operating a continuously variable transmission (CVT) with a launch assist mechanism is provided. The method includes receiving a launch assist signal; engaging a locking mechanism configured and arranged to selectively prevent movement of a movable sheave system independent of an RPM of a primary clutch of the CVT; increasing the RPM of the primary clutch independent of an operator throttle control; and upon receiving a complete launch assist signal, releasing the locking mechanism and returning throttle control to the operator.

### BRIEF DESCRIPTION OF THE DRAWINGS

[0008] The present invention can be more easily understood and further advantages and uses thereof will be more readily apparent, when considered in view of the detailed description and the following figures in which:

[0009] FIG. 1 illustrates a cross-sectional top perspective view of a CVT with launch assist according to one exemplary embodiment;

[0010] FIG. 2 illustrates a side perspective of a first housing section of a housing and an actuator according to one exemplary embodiment;

[0011] FIG. 3A illustrates a partial exploded side view of a movable sheave assembly of a primary clutch according to one exemplary embodiment;

[0012] FIG. 3B is a close up side perspective view of part of the components of the launch assist mechanism of according to one exemplary embodiment;

[0013] FIG. 4A illustrates a cross-sectional side perspective view of the primary clutch and actuator according to one exemplary embodiment;

[0014] FIG. 4B illustrates another cross-sectional side perspective view of the primary clutch and actuator according to one exemplary embodiment;

[0015] FIG. 5A illustrates a cross-sectional side perspective view of the primary clutch and actuator with a launch assist disabled and the primary clutch at idle according to one exemplary embodiment;

[0016] FIG. 5B illustrates a cross-sectional side perspective view of the primary clutch and actuator with a launch assist disabled and the primary clutch rotating at a revolutions per minute that moved the movable sheave assembly towards the fixed sheave assembly according to one exemplary embodiment;

[0017] FIG. 6 illustrates a cross-sectional side perspective view of the primary clutch and actuator with the launch assist enabled according to one exemplary embodiment;

[0018] FIG. 7 illustrates a block diagram of a vehicle according to one exemplary embodiment;

[0019] FIG. 8 illustrates a block diagram of a throttle control system according to one exemplary embodiment; and

[0020] FIG. 9 illustrates a throttle control flow diagram according to one exemplary embodiment.

[0021] In accordance with common practice, the various described features are not drawn to scale but are drawn to emphasize specific features relevant to the subject matter described. Reference characters denote like elements throughout Figures and text.

#### DETAILED DESCRIPTION

[0022] In the following detailed description, reference is made to the accompanying drawings, which form a part hereof, and in which is shown by way of illustration specific embodiments in which the inventions may be practiced. These embodiments are described in sufficient detail to enable those skilled in the art to practice the invention, and it is to be understood that other embodiments may be utilized and that changes may be made without departing from the spirit and scope of the present invention. The following detailed description is, therefore, not to be taken in a limiting sense, and the scope of the present invention is defined only by the claims and equivalents thereof.

[0023] Embodiments of the present invention provide a launch assist mechanism for a CVT that allows of the operator to selectively determine when the drive clutch engages the belt independent of the revolutions per minute (RPM) of the engine. In particular, in embodiments, the operator of a vehicle has the ability to have a higher engagement RPM on a CVT system above the original stock engagement RPM when so desired. This can be applied to any vehicle with a CVT system such as, but not limited to, an ATV, UTV, snowmobile, motor vehicle to name a few. During normal usage, the vehicle will maintain the original stock engagement RPM. In embodiments, the operator may choose to temporarily override the original stock engage-

ment in place of a higher engagement RPM. An example where a higher engagement RPM may be beneficial is during high performance situations when aggressive acceleration is desired. In an example embodiment, a momentary switch is mounted on the steering wheel or handle bars of the vehicle. In other embodiments, the momentary switch is positioned in other locations the operator can reach during operation of the vehicle. Further in embodiments, when the switch is depressed and held, a solenoid or electric actuator mounted to the outer CVT enclosure applies a side force to the end of the primary clutch creating a mechanical lock between the primary clutch cover and a primary clutch post. This allows the engine to increase in RPM without clutch engagement occurring. Once the desired engagement RPM is achieved, the button is released. When the button is released, the side force is removed and the clutch is allowed to unlock and engage the belt, thus propelling the vehicle forward with great thrust. Embodiments alleviate negative performance effects of the original stock engagement RPM while still allowing it to remain intact as it is vital for slow speed vehicle operation and maneuvering. Moreover embodiments still allows for easy servicing and maintenance of the CVT system as well.

[0024] Referring to FIG. 1, a cross-sectional top perspective view of a CVT with launch assist 100 is illustrated. The CVT with launch assist 100 includes housing 101 that houses a primary clutch 102 and a secondary clutch 160. A belt 150 conveys rotation of the primary clutch 102 to the secondary clutch 160. The housing 101 in this embodiment includes a first housing section 101a and a second housing section 101b that are selectively coupled together. The primary clutch 102 is mounted on a central post 190. The central post 190 is rotationally coupled to a crankshaft of an engine (not shown). The primary clutch 102 includes a movable sheave assembly 102a and a fixed sheave assembly 102b. Also illustrated in FIG. 1, is an actuator 130. The actuator 130 in this example embodiment is an electrically actuated actuator 130 including a signal connection port 138 that would be in communication with a switch (not shown) as discussed above.

[0025] FIG. 2 illustrates the first housing section 101a of the housing 101 and the actuator 130. The first housing section 101a of the housing 101 includes a pair of spaced actuator connection passages 126a and 126b upon which threaded attaching posts 136a and 136b (best seen in FIG. 4) of an actuator body 132 of the actuator 130 pass through. The threaded attaching posts are secured to the first housing section 101a via securing nuts 142. The first housing section 101a also includes an activation passage 124 as illustrated in FIG. 2. An activation rod 134 (best seen in FIG. 4) of the actuator 130 passes through the activation passage 124 of the first housing section 101a. Also illustrated in FIG. 2 is a push cup 140 which is acted upon via the activation rod 134 as further discussed in detail below.

[0026] FIG. 3A illustrates a partial exploded view of the movable sheave assembly 102a. The movable sheave assembly 102a includes a main biasing member 104 which is a spring in an embodiment that is received around the central post 190. The movable sheave assembly 102a also includes a primary clutch cover 106, a spider 111 and flyweights 113 (best seen in FIG. 4B). The main biasing member 104 is positioned between the primary clutch cover 106 and the spider 111 to bias the primary clutch cover 106 a select distance from the spider 111. The primary clutch

cover **106** is connected to towers **115a** of a movable base **115** of the movable sheave assembly **102a** that form part of a movable sheave system. The flyweights **113** are pivotally coupled to a movable base **115**. As the primary clutch **102** rotates, a centrifugal force causes the flyweights **113** to pivot out asserting a force on the spider **111**. As the centrifugal force increases, the force by the flyweights **113** on the spider **111** increases therein countering a biasing force of the main biasing member **104**. Since, the spider **111** is axially locked to the central post **190**, the flyweights **113** axially move the movable base **115** along an axis of the central post **190** towards the fixed sheave assembly **102b**. This flyweight-main biasing member configuration moves the movable sheave system of the movable sheave assembly **102a** axially on the center post **190** based on the RPM of the movable sheave assembly **102a**. Other configurations that selectively move the movable sheave assembly **102a** on the center post **190** based on the RPM of the moveable sheave assembly **102a** may be used in other embodiments.

[0027] Referring back to FIG. 3A, the movable sheave assembly **102a** in the embodiment shown, further includes a lock collar **108** that is fastened to the primary clutch cover **106** via fasteners **105**. The lock collar **108** includes ball pockets **108a** which receives locking balls **112**. In one embodiment, the passages through the lock collar **108** that form the ball pockets are not perpendicular to the rotational axis of the primary clutch **102** to aid in operations of the locking balls, lock collar **108** and slide collar **114** as discussed below. The lock collar **108** in an embodiment further includes a plurality of detent passages **108b** (best illustrated in FIG. 5B) that each receive a detent bullet **107** and associated compression spring **109**. The detent bullet-compression spring arrangements provide a retaining force on the locking balls **112** to prevent them from becoming dislodged from their associated ball pockets **108a** under centrifugal force. The lock collar **108** is received around the central post **190** as best illustrated in FIG. 4B. The central post **190** has a first post portion **191** that has a first outer diameter and second post portion **193** that has a second outer diameter. The second outer diameter is larger than the first outer diameter of the first post portion **191**. A ramped step **191a** transitions between the first post portion **191** and the second post portion **193**. This is best illustrated in FIG. 5A.

[0028] The movable sheave assembly **102a** further includes the slide collar **114** with an inner ball retaining groove **114a**. The slide collar **114** is slidably positioned over a portion of the lock collar **108** such that a portion of the locking balls **112** may be received within the inner ball retaining groove **114a** of the slide collar **114**. A return biasing member **110**, which is a wave spring in one embodiment, is positioned between a portion of the lock collar **108** and the slide collar **114** to assert a bias force that positions the inner ball retaining groove **114a** of the slide collar **114** to receive a portion of locking balls **112** under normal operations as discussed below. This is best illustrated in FIG. 5B.

[0029] A retaining clip **116** received in a retaining groove on the lock collar **108** is used to retain the slide collar **114** on the lock collar **108**. A bearing **118** is mounted on a portion of the slide collar **108**. Moreover, a portion of the bearing abuts a step portion of the slide collar **108** such that when the bearing moves axially, the slide collar **114** moves axially. A thrust cap **120** is positioned to engage the bearing **118**. Also illustrated in FIG. 3A are fasteners **122** that couple the

primary clutch cover **106** to the towers **115a** of the movable base **115** of the movable sheave assembly **102a**. Hence, the movable base **115**, the primary clutch cover **106** and the lock collar **108** are all coupled together and all axially move together on the central post **190**.

[0030] FIG. 3B illustrates a close up side perspective view of part of the components of the launch assist mechanism. In particular, FIG. 3B illustrates the slide collar **114**, the locking balls **112**, the return biasing member **110**, the lock collar **108**, the detent bullets **107** and the compression springs **109**. As illustrated, slide collar **114** includes an interior surface **114b** in which the inner ball retaining groove **114a** is formed. As further illustrated, the lock collar **108** includes a plurality of spaced ball pockets **108a**. The ball pockets **108a** in this embodiment are not perpendicular to an axis of rotation of the primary clutch **102**. Further, the ball pockets **108a** extend all the way through surfaces of the lock collar **108** such that portions of the locking balls can extend beyond the surfaces of the lock collar **108** to respectfully engage the central post **190** and the interior surface **114b** of the slide collar **114** as described below. The return biasing member **110** is received around a first outer surface portion **108c** of the lock collar **108** an up against a seat portion formed by the lock collar **108**. The locking balls **112** are inserted in the respective ball pockets **108a** of the lock collar **108**. The slide collar **114** is then positioned on the lock collar **108** so that the interior **114b** of the slide collar **114** slidably engages the first outer surface **108c** of the lock collar **108**. Further each compression springs **109** is received in a cavity (not shown) of an associated detent bullets **107**. The detent-compression spring arrangement is received in detent passages **108b** (best illustrated in FIG. 5B) as discussed above.

[0031] FIGS. 4A and 4B illustrate different cross-sectional assembled side views of the movable sheave assembly **102a** and the actuator **130**. In particular, FIG. 4A illustrates the lock collar-locking ball arrangement and FIG. 4B illustrates the flyweight-spider arrangement. FIG. 5A illustrates a close up cross-sectional side view of the movable sheave assembly **102a** and the actuator **130** in a launch assist disabled configuration while the primary clutch **102** is at idle. In this configuration, a first portion of the locking balls **112** engage an interior surface of the slide collar **114** proximate the interior groove **114a** of the slide collar **114**. A second portion of the locking balls **112** engage the first post portion **191** and ramped step **191a** of the central post **190**. FIG. 5B illustrates a cross-sectional side perspective view of the primary clutch and actuator with a launch assist disabled and the primary clutch **102** rotating at a RPM that moved the movable sheave system of the movable sheave assembly **102a** towards the fixed sheave assembly **102b**. As illustrated, in this configuration the first portion of the locking balls **112** are received within the interior groove **114a** of the slide collar **114** and the second portion engages the second post portion **193**. This configuration allows the locking balls **112** to move up the ramped step **191a** to engage the second post portion **193** of the central post **190** as the movable sheave system that includes the primary clutch cover **106** and movable base **115** of the movable sheave assembly **102a** move axially along the center post **190** as described above with the flyweights **113** countering the bias force of the main bias member **104** during increased centrifugal force.

[0032] FIG. 6 illustrates a close up cross-sectional side view of the movable sheave assembly **102a** and the actuator **130** in a launch assist configuration. As discussed above, the

launch configuration occurs via activation of a switch or button by the operator of the vehicle. Activation of the actuator **130** causes the activation rod **134** that is attached to the push cap **140**, to axially contact and move the thrust cap **120**. This in turn axially moves the bearing **118** and the slide collar **114** towards the primary clutch cover **106**. As the slide collar **114** moves axially, the locking balls **112** are forced away from the **114a** inner ball retaining groove **114a** of the slide collar **114**. The force of the inner surface of the slide collar on the first portion of the locking balls **112** forcing the second portion of the locking balls into the first post portion **191** and ramped step **191a** holds the movable sheave system of the movable sheave assembly **102a** in place when the locking mechanism is activated. This prevents the lock collar **108** from axially moving in relation to the central post **190**. Since, the lock collar **108** is attached to the primary clutch cover **106** via fasteners **105**, the primary clutch cover **106** and movable base **115** are prevented from moving towards the fixed sheave assembly **102b** even though the flyweights are asserting a force on the spider **111**. Hence, as long as the actuator **130** is activated, an increase in RPMs of the movable sheave assembly **102a** will not cause the moveable sheave assembly **102a** to move towards the fixed sheave assembly **102b** and hence the belt **150** will not be engaged (pinched) to transfer torque to the secondary clutch **160**.

**[0033]** Once the desired RPM is reached, the operator disables the launch assistant causing the actuator to retract the activation rod **134**. This allows the return biasing member **110** to move the slide collar **114** so that the locking balls **112** align with the inner ball retaining groove **114a** of the slide collar **114**. This reduces the pressure on the second portion of the locking balls **112** allowing the locking balls **112** to move up the ramped step **191a** while the lock collar **108** moves axially on the central post **190** in response to a force created by the flyweight-spider configuration. As discussed above, the flyweights **113** on the spider **111** causes the movable sheave assembly **102a** to move towards the fixed sheave assembly **102b** to engage the belt **150**. Hence, the belt can be engaged at a desired RPM as directed by the operator in embodiments.

**[0034]** In embodiments, the primary clutch **102** is locked from shifting during RPM increase until a desired moment is created by a force of the actuator **130**. Although the actuator **103** described above and illustrated in the Figures is an electrical actuator, any type of actuator system can be used including, but not limited to, an electronic solenoid, a hydraulic master/slave piston arrangement and a manual mechanism with the use of a push or pull cable or other like systems. The physical location of the above mentioned devices may be mounted to either an outer or inner CVT housing or surrounding panels of the vehicle to eliminate the need to attach directly to the spinning CVT components. In other embodiments, they are attached directly to the spinning CVT components.

**[0035]** One method for setting a maximum RPM limiter for the launch control system is by utilizing an electrical signal from the actuator or other switch indication methods, etc. and incorporating it into a vehicle Electronic Control Unit (ECU) to determine a desired maximum RPM limit. For example, FIG. 7, illustrates a block diagram of vehicle **200** with such a system. In particular, the vehicle **200** includes a motor **202** that supplies torque to the CVT **100**. The CVT **100** is in rotational communication with a drive-

train **208** of the vehicle **200**. The drivetrain **208** may include, but is not limited to, a further transmission system, one or more drive shafts, one or more differentials, one or more wheels, one or more tracks, etc. The vehicle **200** in this example embodiment further includes an ECU **206** that is in communication with a switch **204**. The ECU **206** is further in communication with the actuator **130**. As discussed above, in an embodiment the ECU **206** may control the actuator **130** to limit an RPMs of the CVT **100**.

**[0036]** In addition, in some embodiments that incorporate different vehicle operating modes, such as, sport mode, stock mode, etc., the ECU **206** of the vehicle **200** may utilize the stock clutch engagement RPM when a stock mode is selected. However, when another mode, such as sport mode is selected, the ECU may automatically employ a higher clutch engagement RPM by activating the launch assist mechanism **130** described above. Hence in this embodiment, the ECU monitors the position of the switch and controls the activation of the activator **130** of the locking mechanism according to a selected switch mode position.

**[0037]** Further another embodiment, an outer groove on the central post **190** may be used instead of the first post portion **191** and ramped step **191a** configuration. Moreover, the position of the outer groove or the first post portion **191** and **191a** may be placed at different locations on the outer parameter of the central post **190** to lock the CVT into a fixed ratio for other purposes such as for better vehicle fuel mileage, lower operating noise, etc.

**[0038]** FIG. 8 illustrates a block diagram of a throttle control system **300** according to one exemplary embodiment. This example embodiment include a system controller **302** and a launch assist throttle controller **312**. The system controller **302** may be an electronic control module (ECM), an electronic control unit (ECU) or the like. In general, each of the system controller **302** and the launch assist throttle controller **312** may include any one or more of a processor, microprocessor, a digital signal processor (DSP), an application specific integrated circuit (ASIC), a field program gate array (FPGA), or equivalent discrete or integrated logic circuitry. In some example embodiments, controller may include multiple components, such as any combination of one or more microprocessors, one or more controllers, one or more DSPs, one or more ASICs, one or more FPGAs, as well as other discrete or integrated logic circuitry. The functions attributed to the controller herein may be embodied as software, firmware, hardware or any combination thereof. The system controller **302** may be part of a system controller (such as the ECU) or a component controller. Each controller **302** and **312** may include memory with computer-readable operating instructions that, when executed by the respective controller **302** or **312** provides functions of the throttle control. The computer readable instructions may be encoded within the memory. The memory may comprise computer readable storage media including any volatile, nonvolatile, magnetic, optical, or electrical media, such as, but not limited to, a random access memory (RAM), read-only memory (ROM), non-volatile RAM (NVRAM), electrically-erasable programmable ROM (EEPROM), flash memory, or any other storage medium.

**[0039]** The system controller **302** in this example embodiment provides a select voltage to an operator throttle input **306**. The operator throttle input **306** may be a pedal, lever, turn-able grip or any other type of operator input that adjusts the RPM of the vehicle. In normal operation, the operator

throttle input **306** outputs a throttle control signal back to the system controller **320**. The throttle control signal is based on an effect of the position of the operator throttle input on the voltage provided by the system controller **302** in this embodiment. The system controller **302**, in this normal operation would control the throttle **308** accordingly.

**[0040]** In the embodiment of FIG. **8**, when the launch assist switch/button **304** is depressed the launch assist actuator **130** is activated as discussed above. Activation of the launch assist switch/button **304** (or generally a launch assist activation member **304**) in this embodiment, also activates (trips) relay **310**. When activated, the relay redirects the voltage signal from the system controller **302** to the launch assist throttle controller **312**. The launch assist throttle controller **312** then provides the throttle control signal back to the system controller **302** to control the throttle **308** (or throttle body **308**). Hence, when the relay **310** is activated, the operator throttle input **306** has no effect on the operation of the throttle **308**. The launch assist throttle controller **312** provides a desired throttle control signal for an application. For example, it may be desirable to place the RPM at 100 percent or even above a normal maximum RPM. In embodiment, the operator may select the desired throttle control signal for launch assist. In one embodiment, the launch assist throttle controller **312** is a simple variator that simply takes the voltage signal from the system controller **320** and adjusts it to generate the throttle control signal of a select voltage. The variator **312** may include a dial to selectively adjust the voltage in the throttle control signal.

**[0041]** Once the launch assist switch or button is released or deactivated, the relay **310** returns the routing of the voltage signal from the system controller **302** to the operator throttle input **306** while the launch assist mechanism is applied to launch the vehicle. Hence, normal operations of the operator throttle input **306** is reestablished upon the release or deactivation of the launch assist switch/button **304**. Although, only one communication link for each of the voltage signal and the throttle control signal are shown in FIG. **8**, a pair of communication links for each signal may be used for redundancy purposes.

**[0042]** An example of a throttle control flow diagram **400** is illustrated in FIG. **9**. The throttle control flow diagram **400** is used in an example embodiment to control the RPM provided by the motor **202**. The throttle control flow diagram **400** of FIG. **9** is provided as a series of sequential steps. The sequence of steps may occur in a different order in other embodiments. Hence, embodiments are not limited to sequence provided in FIG. **9**.

**[0043]** The process of the a throttle control flow diagram **400** of FIG. **9** begins at step **(402)** where the controller **402** monitors for a launch assist signal (LAS) that is generated by the activation of the launch assist switch/button **304** by the operator of the vehicle. If no LAS is detected at step **(404)**, the controller **302** continues monitoring at step **(402)**. If an LAS is detected at step **(404)**, the launch assist (LA) is engaged at step **(406)**. As discussed above, the LA assist implements the locking mechanism to selectively prevent movement of the movable sheave system independent of the RPM the primary clutch **102** is experiencing. The RPM provided by the motor **202** is then increased independent of the throttle input provided by the operator at step **(408)**. It step **(410)** it is determined if a complete launch assist signal has been received. In one embodiment, this signal is generated once the switch/button **304** is switched/released. If it

is determined a complete launch assist signal has not been received (i.e. the switch/button **304** is still activated) at step **(410)**, the RPM continue to increase at step **(408)**. Embodiments employ a governor that will limit the maximum RPM to a select value. Once the RPM has reached 100 percent of the maximum select value (or another select value), the RPM will not increase any farther.

**[0044]** Once it is determined a complete launch assist signal is received (i.e. the switch/button **304** is no longer activated) at step **(410)**, the LA is released at step **(412)** and the throttle control is returned to the throttle input provided by the operator at step **(414)**. The process then continues at step **(402)** monitoring for another LAS signal.

**[0045]** Hence, in the example embodiment of FIG. **9**, a method is provided to increase the RPM independent of the operators throttle position during launch assist operations to ensure a benefit of the launch assist. For example, if the launch assist mechanism is activated while the throttle is held by the operator at only 30 percent of the maximum RPM allowed, the benefit of the launch assist will not be fully realized. Independently of operator throttle position (the operator throttle input) the method increases the RPM to a select value. Since, the operator throttle input is disconnected during the launch assist, even if the operator manipulates the operator throttle input to 100 percent it will have no effect on the RPM. As discussed, the system increases the RPM to a select value independent of the operator throttle position during launch assist so the full benefit of the launch assist mechanism is realized when the switch/button is released (i.e. deactivated).

#### Example Embodiments

**[0046]** Example 1 is a primary clutch of a continuously variable transmission with a launch assist mechanism. The primary clutch includes a central post, a fixed sheave assembly, a movable sheave assembly and a locking mechanism. The central post is configured to receive rotational torque from a motor. The fixed sheave assembly is statically mounted on the central post. The movable sheave assembly is mounted on the central post. The movable sheave assembly includes a movable sheave system that is configured to move axially on the central post towards the fixed sheave assembly as RPM of the primary clutch increase. The locking mechanism is configured and arranged to selectively prevent movement of the movable sheave system independent of the RPM of the primary clutch.

**[0047]** Example 2, includes the primary clutch of Example 1, wherein the movable sheave assembly includes a spider statically mounted to the central post and the movable sheave system of the movable sheave assembly includes a movable base, a primary clutch cover, a main biasing member and at least one flyweight. The primary clutch cover is coupled to the movable base. The main biasing member is positioned to assert a main biasing force to distance the primary clutch cover from the spider. The at least one flyweight an main biasing member forming a flyweight-main biasing member configuration to selectively move at least portion of the movable sheave assembly axially on the central post. The at least one flyweight is pivotally coupled to the movable base. The at least one flyweight is configured and arranged to engage the spider as the RPM of the primary clutch increase to assert a force that counters the main biasing force of the main biasing member to move the

primary clutch cover and movable base axially towards the fixed sheave assembly along the central post.

**[0048]** Example 3 includes the primary clutch of any of the Examples 1-2, wherein the locking mechanism further includes a locking collar, a plurality of locking balls, a slide collar and an actuator. The lock collar is mounted around a portion of the central post. The lock collar has a plurality of ball pockets. Each locking ball is received in an associated ball pocket of the plurality of ball pockets of the lock collar. The slide collar is received around a portion of the lock collar. The slide collar has an inner ball retaining groove. Each locking ball of the plurality of locking balls has a first portion selectively received within the inner retaining groove. The actuator is configured to axially move the slide collar when activated to force the first portion of each locking ball out of the inner retaining groove of the slide collar and force a second portion of each locking ball into at least a ramped step on an outer surface of the central post to selectively prevent axial movement of the lock collar in relation to the central post.

**[0049]** Example 4 includes the primary clutch of Example 3, wherein the locking mechanism further includes a return biasing member positioned to bias the slide collar so the first portion of each locking ball is received within the inner retaining groove of the slide collar when the actuator is not activated and the movable sheave system is moving axially on the center post.

**[0050]** Example 5 includes the primary clutch of any of the Examples 3-4, wherein the locking mechanism further includes a bearing, a thrust cap and a push cap. The bearing engages a portion of the slide collar. The thrust cap engages a portion of the bearing. The push cap engages an activation rod of the actuator. The thrust cap is further configured to engage the thrust cap when the actuator is activated.

**[0051]** Example 6 includes the primary clutch of any of the Examples 1-5, wherein the locking mechanism further includes a user activated switch to selectively activate the locking mechanism.

**[0052]** Example 7 includes the primary clutch of any of the Examples 1-6, wherein the locking mechanism further includes a vehicle electronic unit configured to at least one of set a maximum RPM launch control for the locking mechanism and control activation of the locking mechanism according to a selected switch mode position.

**[0053]** Example 8 is a primary clutch of a continuously variable transmission with a launch assist mechanism. The primary clutch includes a central post, a fixed sheave assembly and a movable sheave assembly. The central post is configured to receive rotational torque from a motor. The fixed sheave assembly is statically mounted on the central post. The movable sheave assembly is mounted on the central post. The movable sheave assembly includes a spider, a movable base, a primary clutch cover, a main biasing member and at least one flyweight. The spider is statically mounted to the central post. The primary clutch cover is coupled to the movable base. The main biasing member is positioned to assert a main biasing force to distance the primary clutch cover from the spider. Moreover, the least one flyweight forms a flyweight-main biasing member configuration to selectively move at least portion of the movable sheave assembly axially on the central post. The at least one flyweight pivotally coupled to the movable base. The at least one flyweight configured and arranged to engage the spider as RPM of the primary clutch increases to

assert a force that counters the main biasing force of the main biasing member to move the primary clutch cover and movable base axially towards the fixed sheave assembly along the central post. Further a locking mechanism is included that is configured and arranged to selectively prevent movement of the primary clutch cover and movable base independent of the flyweight-main biasing member configuration.

**[0054]** Example 9 includes the primary clutch of Example 8, wherein the locking mechanism further includes a lock collar, a plurality of locking balls, a slide collar and an actuator. The lock collar is mounted around a portion of the central post. The lock collar has a plurality of ball pockets. Each locking ball is received in an associated ball pocket of the plurality of ball pockets of the lock collar. The slide collar is received around a portion of the lock collar. The slide collar has an inner ball retaining groove. Each locking ball of the plurality of locking balls have a first portion that is selectively received within the inner retaining groove. The actuator is configured to axially move the slide collar when activated to force the first portion of each locking ball out of the inner retaining groove of the slide collar and force a second portion of each locking ball into at least a ramped step on an outer surface of the central post to selectively prevent axial movement of the lock collar in relation to the central post.

**[0055]** Example 10 includes the primary clutch the Example 9, wherein the locking mechanism further includes a return biasing member positioned to bias the slide collar so the first portion of each locking ball is received within the inner retaining groove of the slide collar when the actuator is not activated.

**[0056]** Example 11 includes the primary clutch of any of the Examples 9-10, wherein the locking mechanism further includes a bearing, a thrust cap and a push cap. The bearing engages a portion of the slide collar. The thrust cap engages a portion of the bearing. The push cap engages an activation rod of the actuator. The thrust cap is further configured to engage the thrust cap when the actuator is activated.

**[0057]** Example 12 includes the primary clutch of any of the Examples 8-11, wherein the locking mechanism further includes a user activated switch to selectively activate the locking mechanism.

**[0058]** Example 13 includes the primary clutch of any of the Examples 8-12, wherein the locking mechanism further includes a vehicle electronic unit configured to at least one of set a maximum RPM launch control for the locking mechanism and control activation of the locking mechanism according to a selected switch mode position.

**[0059]** Example 14 includes the primary clutch of any of the Examples 9-13, wherein the lock collar is coupled to the primary clutch cover of the movable sheave assembly.

**[0060]** Example 15 is a vehicle with a launch assist mechanism. The vehicle includes an engine to generate torque, a continuously variable transmission and drive train. The continuously variable transmission includes a primary clutch and a secondary clutch. The secondary clutch is rotationally coupled to the primary clutch via endless looped belt. The primary clutch includes a central post, a fixed sheave assembly, a movable sheave assembly and a locking mechanism. The central post is configured to receive rotational torque from the motor. The fixed sheave assembly is statically mounted on the central post. The movable sheave assembly is mounted on the central post. The movable

sheave assembly includes a movable sheave system that is configured to move axially on the central post towards the fixed sheave assembly as RPM of the primary clutch increases. The locking mechanism is configured and arranged to selectively prevent movement of the movable sheave system independent of RPM of the primary clutch. The drive train is coupled to the secondary clutch.

**[0061]** Example 16 includes the vehicle of Example 15, wherein the locking mechanism further includes a lock collar, a plurality of locking balls, a slide collar, an actuator and a return biasing member. The lock collar is mounted around a portion of the central post. The lock collar has a plurality of ball pockets. Each locking ball is received in an associated ball pocket of the plurality of ball pockets of the lock collar. The slide collar is received around a portion of the lock collar. The slide collar has an inner ball retaining groove. Each locking ball of the plurality of locking balls have a first portion that is selectively received within the inner retaining groove. The actuator is configured to axially move the slide collar when activated to force the first portion of each locking ball out of the inner retaining groove of the slide collar and force a second portion of each locking ball into at least a ramped step on an outer surface of the central post to selectively prevent axial movement of the lock collar in relation to the central post. The return biasing member is positioned to bias the slide collar so the first portion of each locking ball is received within the inner retaining groove of the slide collar when the actuator is not activated.

**[0062]** Example 17 includes the vehicle of Example 16, wherein the locking mechanism further includes a bearing, a thrust cap and a push cap. The bearing engages a portion of the slide collar. The thrust cap engages a portion of the bearing and the push cap engages an activation rod of the actuator. The thrust cap is further configured to engage the thrust cap when the actuator is activated.

**[0063]** Example 18 includes the vehicle of any of the Examples 15-17, wherein the locking mechanism further includes a user activated switch in communication with the actuator to selectively activate the actuator.

**[0064]** Example 19 includes the vehicle of any of the Examples 15-18, wherein the locking mechanism further includes a vehicle electronic unit configured to at least one of set a maximum RPM launch control for the locking mechanism and control activation of the locking mechanism according to a selected switch mode position.

**[0065]** Example 20 includes the vehicle of any of the Examples 15-19, further including a launch assist activation member, a throttle, an operator throttle input, a system controller and a launch assist. The launch assist activation member is used to selectively activate the locking mechanism. The throttle is used to control the RPM of the engine. The operator throttle input is used to provide operator input on a desired RPM of the engine. The system controller is in communication with the operator throttle input. The system controller is further configured to control operation of the throttle based at least in part on a throttle control signal from the operator throttle input. The launch assist throttle controller system is coupled to generate a substitute throttle control signal used by the system controller that is independent of the throttle control signal provided by the operator throttle input when the launch assist activation member is activated.

**[0066]** Example 21 is a method of operating a continuously variable transmission (CVT) with a launch assist

mechanism. The method includes receiving a launch assist signal; engaging a locking mechanism configured and arranged to selectively prevent movement of a movable sheave system independent of an RPM of a primary clutch of the CVT; increasing the RPM of the primary clutch independent of an operator throttle control; and upon receiving a complete launch assist signal, releasing the locking mechanism and returning throttle control to the operator.

**[0067]** Although specific embodiments have been illustrated and described herein, it will be appreciated by those of ordinary skill in the art that any arrangement, which is calculated to achieve the same purpose, may be substituted for the specific embodiment shown. This application is intended to cover any adaptations or variations of the present invention. Therefore, it is manifestly intended that this invention be limited only by the claims and the equivalents thereof.

1. A primary clutch of a continuously variable transmission with a launch assist mechanism, the primary clutch comprising:

- a central post configured to receive rotational torque from a motor;
- a fixed sheave assembly statically mounted on the central post;
- a movable sheave assembly mounted on the central post, the movable sheave assembly including a movable sheave system that is configured to move axially on the central post towards the fixed sheave assembly as revolutions per minute (RPM) of the primary clutch increases; and
- a locking mechanism configured and arranged to selectively prevent movement of the movable sheave system independent of the RPM of the primary clutch.

2. The primary clutch of claim 1, further wherein:

- the movable sheave assembly includes a spider statically mounted to the central post; and
- the movable sheave system of the movable sheave assembly includes,

- a movable base,
- a primary clutch cover coupled to the movable base,
- a main biasing member positioned to assert a main biasing force to distance the primary clutch cover from the spider, and

- at least one flyweight, the at least one flyweight and main biasing member forming a flyweight-main biasing member configuration to selectively move at least portion of the movable sheave assembly axially on the central post, the at least one flyweight pivotally coupled to the movable base, the at least one flyweight configured and arranged to engage the spider as the RPM of the primary clutch increase to assert a force that counters the main biasing force of the main biasing member to move the primary clutch cover and movable base axially towards the fixed sheave assembly along the central post.

3. The primary clutch of claim 1, wherein the locking mechanism further comprises:

- a lock collar mounted around a portion of the central post, the lock collar having a plurality of ball pockets;
- a plurality of locking balls, each locking ball received in an associated ball pocket of the plurality of ball pockets of the lock collar;
- a slide collar received around a portion of the lock collar, the slide collar having an inner ball retaining groove,

- each locking ball of the plurality of locking balls having a first portion selectively received within the inner retaining groove; and
- an actuator configured to axially move the slide collar when activated to force the first portion of each locking ball out of the inner retaining groove of the slide collar and force a second portion of each locking ball into at least a ramped step on an outer surface of the central post to selectively prevent axial movement of the lock collar in relation to the central post.
4. The primary clutch of claim 3, wherein the locking mechanism further comprises:
- a return biasing member positioned to bias the slide collar so the first portion of each locking ball is received within the inner retaining groove of the slide collar when the actuator is not activated and the movable sheave system is moving axially on the center post.
5. The primary clutch of claim 3, wherein the locking mechanism further comprises:
- a bearing engaging a portion of the slide collar;
  - a thrust cap engaging a portion of the bearing; and
  - a push cap engaging an activation rod of the actuator, the thrust cap further configured to engage the thrust cap when the actuator is activated.
6. The primary clutch of claim 1, wherein the locking mechanism further comprises:
- a user activated switch to selectively activate the locking mechanism.
7. The primary clutch of claim 1, wherein the locking mechanism further comprises:
- a vehicle electronic unit configured to at least one of set a maximum RPM launch control for the locking mechanism and control activation of the locking mechanism according to a selected switch mode position.
8. A primary clutch of a continuously variable transmission with a launch assist mechanism, the primary clutch comprising:
- a central post configured to receive rotational torque from a motor;
  - a fixed sheave assembly statically mounted on the central post;
  - a movable sheave assembly mounted on the central post, the movable sheave assembly including,
    - a spider statically mounted to the central post,
    - a movable base,
    - a primary clutch cover coupled to the movable base,
    - a main biasing member positioned to assert a main biasing force to distance the primary clutch cover from the spider, and
  - at least one flyweight forming a flyweight-main biasing member configuration to selectively move at least portion of the movable sheave assembly axially on the central post, the at least one flyweight pivotally coupled to the movable base, the at least one flyweight configured and arranged to engage the spider as revolutions per minute (RPM) of the primary clutch increases to assert a force that counters the main biasing force of the main biasing member to move the primary clutch cover and movable base axially towards the fixed sheave assembly along the central post; and
  - a locking mechanism configured and arranged to selectively prevent movement of the primary clutch cover and movable base independent of the flyweight-main biasing member configuration.
9. The primary clutch of claim 1, wherein the locking mechanism further comprises:
- a lock collar mounted around a portion of the central post, the lock collar having a plurality of ball pockets;
  - a plurality of locking balls, each locking ball received in an associated ball pocket of the plurality of ball pockets of the lock collar;
  - a slide collar received around a portion of the lock collar, the slide collar having an inner ball retaining groove, each locking ball of the plurality of locking balls having a first portion selectively received within the inner retaining groove; and
  - an actuator configured to axially move the slide collar when activated to force the first portion of each locking ball out of the inner retaining groove of the slide collar and force a second portion of each locking ball into at least a ramped step on an outer surface of the central post to selectively prevent axial movement of the lock collar in relation to the central post.
10. The primary clutch of claim 9, wherein the locking mechanism further comprises:
- a return biasing member positioned to bias the slide collar so the first portion of each locking ball is received within the inner retaining groove of the slide collar when the actuator is not activated.
11. The primary clutch of claim 9, wherein the locking mechanism further comprises:
- a bearing engaging a portion of the slide collar;
  - a thrust cap engaging a portion of the bearing; and
  - a push cap engaging an activation rod of the actuator, the thrust cap further configured to engage the thrust cap when the actuator is activated.
12. The primary clutch of claim 8, wherein the locking mechanism further comprises:
- a user activated switch to selectively activate the locking mechanism.
13. The primary clutch of claim 8, wherein the locking mechanism further comprises:
- a vehicle electronic unit configured to at least one of set a maximum RPM launch control for the locking mechanism and control activation of the locking mechanism according to a selected switch mode position.
14. The primary clutch of claim 9, wherein the lock collar is coupled to the primary clutch cover of the movable sheave assembly.
15. A vehicle with a launch assist mechanism, the vehicle comprising:
- an engine to generate torque;
  - a continuously variable transmission including a primary clutch and a secondary clutch, the secondary clutch rotationally coupled to the primary clutch via endless looped belt, the primary clutch including,
    - a central post coupled to receive rotational torque from a motor;
    - a fixed sheave assembly statically mounted on the central post,
    - a movable sheave assembly mounted on the central post, the movable sheave assembly including a movable sheave system that is configured to move axially

on the central post towards the fixed sheave assembly as revolutions per minute (RPM) of the primary clutch increases, and

a locking mechanism configured and arranged to selectively prevent movement of the movable sheave system independent of RPM of the primary clutch; and

a drive train coupled to the secondary clutch.

**16.** The vehicle of claim **15**, wherein the locking mechanism further comprises:

a lock collar mounted around a portion of the central post, the lock collar having a plurality of ball pockets;

a plurality of locking balls, each locking ball received in an associated ball pocket of the plurality of ball pockets of the lock collar;

a slide collar received around a portion of the lock collar, the slide collar having an inner ball retaining groove, each locking ball of the plurality of locking balls having a first portion selectively received within the inner retaining groove;

an actuator configured to axially move the slide collar when activated to force the first portion of each locking ball out of the inner retaining groove of the slide collar and force a second portion of each locking ball into at least a ramped step on an outer surface of the central post to selectively prevent axial movement of the lock collar in relation to the central post; and

a return biasing member positioned to bias the slide collar so the first portion of each locking ball is received within the inner retaining groove of the slide collar when the actuator is not activated.

**17.** The vehicle of claim **16**, wherein the locking mechanism further comprises:

a bearing engaging a portion of the slide collar;

a thrust cap engaging a portion of the bearing; and

a push cap engaging an activation rod of the actuator, the thrust cap further configured to engage the thrust cap when the actuator is activated.

**18.** The vehicle of claim **16**, wherein the locking mechanism further comprises:

a user activated switch in communication with the actuator to selectively activate the actuator.

**19.** The vehicle of claim **15**, wherein the locking mechanism further comprises:

a vehicle electronic unit configured to at least one of set a maximum RPM launch control for the locking mechanism and control activation of the locking mechanism according to a selected switch mode position.

**20.** The vehicle of claim **15**, further comprising:

a launch assist activation member to selectively activate the locking mechanism;

a throttle to control the RPM of the engine;

an operator throttle input to provide operator input on a desired RPM of the engine;

a system controller in communication with the operator throttle input, the system controller further configured to control operation of the throttle based at least in part on a throttle control signal from the operator throttle input; and

a launch assist throttle controller system coupled to generate a substitute throttle control signal used by the system controller that is independent of the throttle control signal provided by the operator throttle input when the launch assist activation member is activated.

**21.** A method of operating a continuously variable transmission (CVT) with a launch assist mechanism, the method comprising:

receiving a launch assist signal;

engaging a locking mechanism configured and arranged to selectively prevent movement of a movable sheave system independent of an RPM of a primary clutch of the CVT;

increasing the RPM of the primary clutch independent of an operator throttle control; and

upon receiving a complete launch assist signal, releasing the locking mechanism and returning throttle control to the operator.

\* \* \* \* \*