



(19) **United States**

(12) **Patent Application Publication**
Dandurand et al.

(10) **Pub. No.: US 2025/0136203 A1**

(43) **Pub. Date: May 1, 2025**

(54) **TRACK SYSTEM FOR TRACTION OF AN OFF-ROAD VEHICLE SUCH AS A SNOWMOBILE OR AN ALL-TERRAIN VEHICLE (ATV)**

Publication Classification

- (51) **Int. Cl.**
B62D 55/24 (2006.01)
B62D 55/04 (2006.01)
B62D 55/065 (2006.01)
B62D 55/14 (2006.01)
B62D 55/30 (2006.01)
B62M 27/02 (2006.01)
- (52) **U.S. Cl.**
 CPC *B62D 55/244* (2013.01); *B62D 55/04* (2013.01); *B62D 55/065* (2013.01); *B62D 55/14* (2013.01); *B62D 55/24* (2013.01); *B62D 55/242* (2013.01); *B62D 55/305* (2013.01); *B62M 27/02* (2013.01); *B62M 2027/027* (2013.01)

- (71) Applicant: **Camso Inc.**, Magog (CA)
- (72) Inventors: **Jules Dandurand**, Sherbrooke (CA); **Denis Courtemanche**, Val Joli (CA); **Pascal Labbé**, Sherbrooke (CA); **Linda Poulin**, Compton (CA)
- (73) Assignee: **Camso Inc.**, Magog (CA)

(21) Appl. No.: **19/010,875**

(22) Filed: **Jan. 6, 2025**

Related U.S. Application Data

- (63) Continuation of application No. 17/021,866, filed on Sep. 15, 2020, now Pat. No. 12,208,844, which is a continuation of application No. 13/689,128, filed on Nov. 29, 2012, now abandoned.
- (60) Provisional application No. 61/564,630, filed on Nov. 29, 2011.

(57) **ABSTRACT**

A track system for traction of an off-road vehicle such as a snowmobile or an all-terrain vehicle (ATV). The track system comprises a track-engaging assembly and a track disposed around the track-engaging assembly. The track system may be configured to have a reduced noise profile so as to generate less noise, enhanced track rigidity characteristics to improve its traction and floatation, and/or other features improving use and performance of the off-road vehicle.

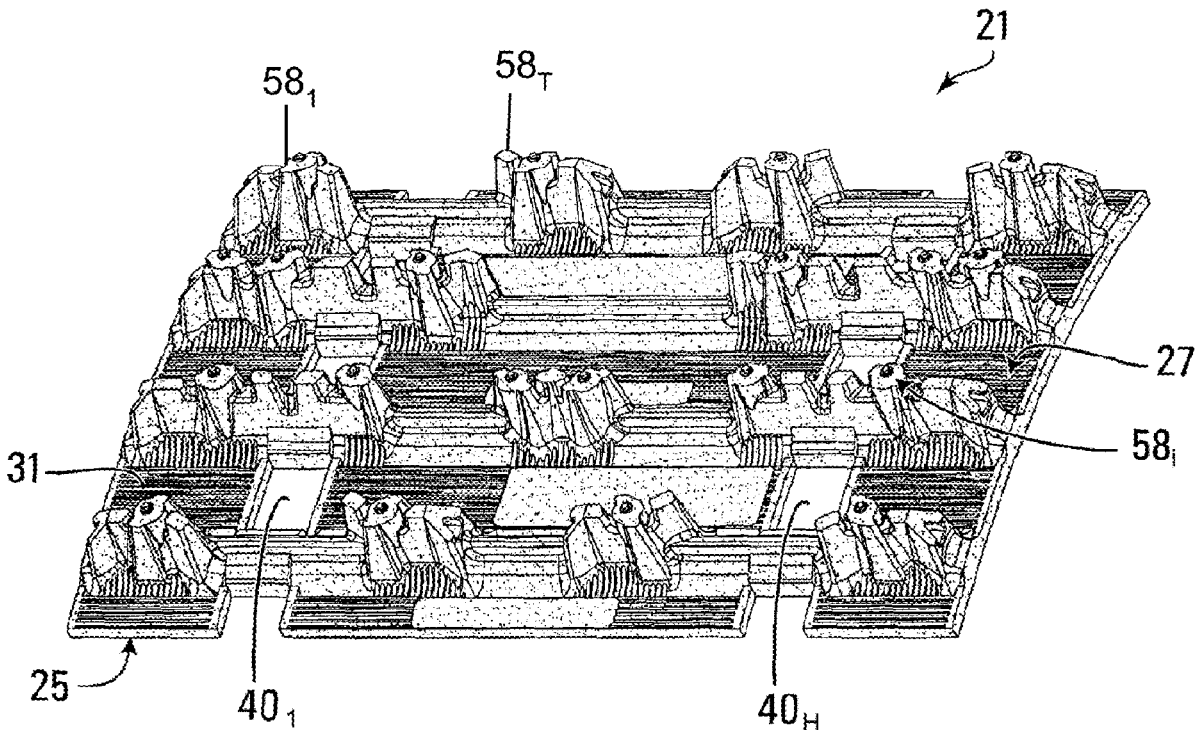

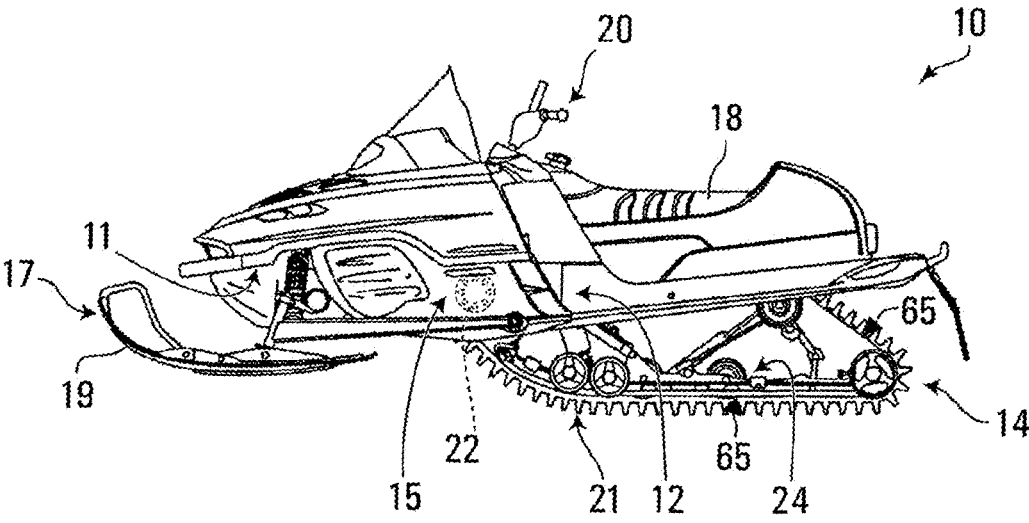

FIG. 1

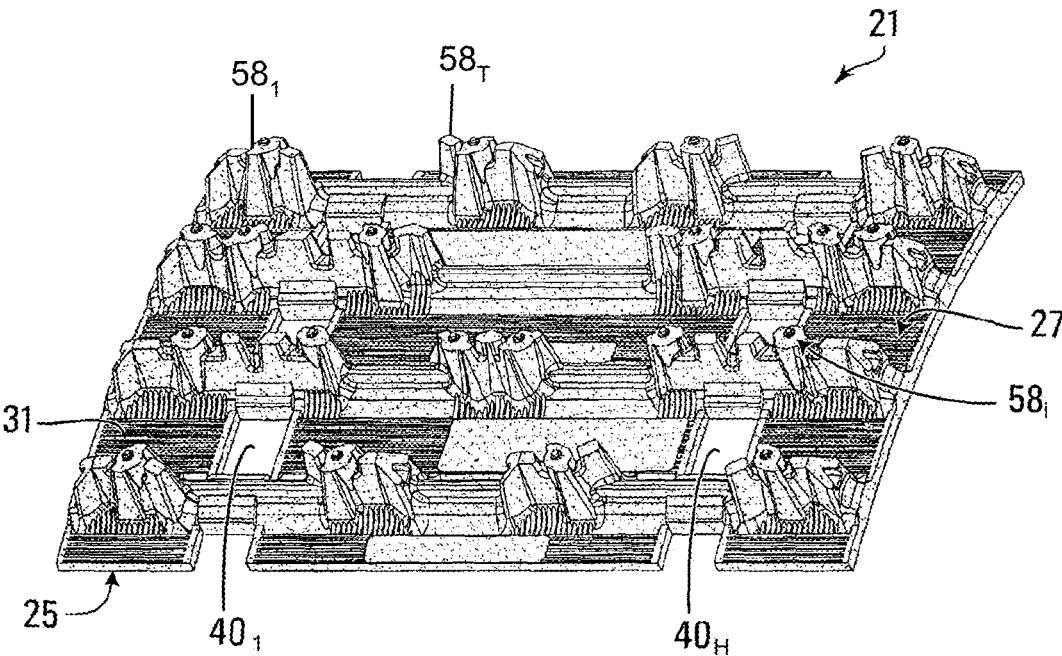

FIG. 3

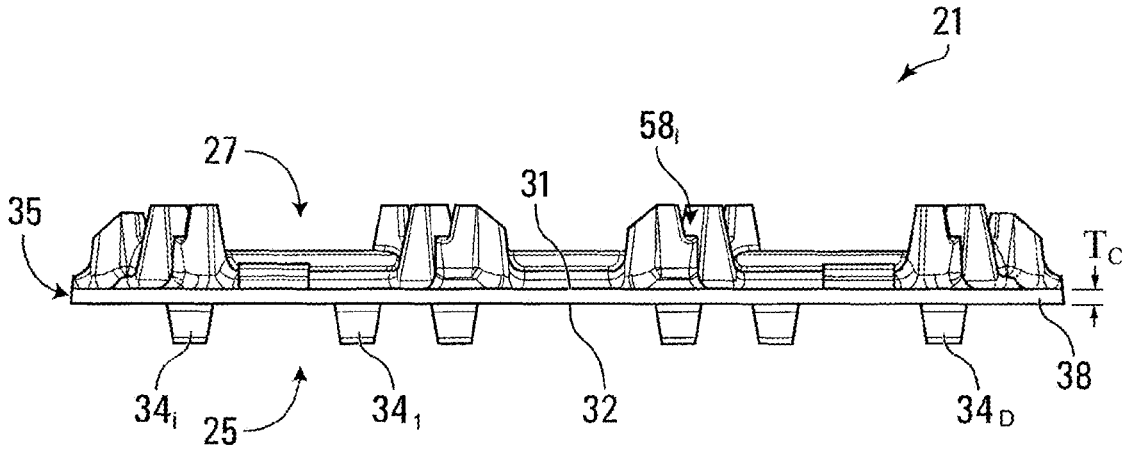

FIG. 4

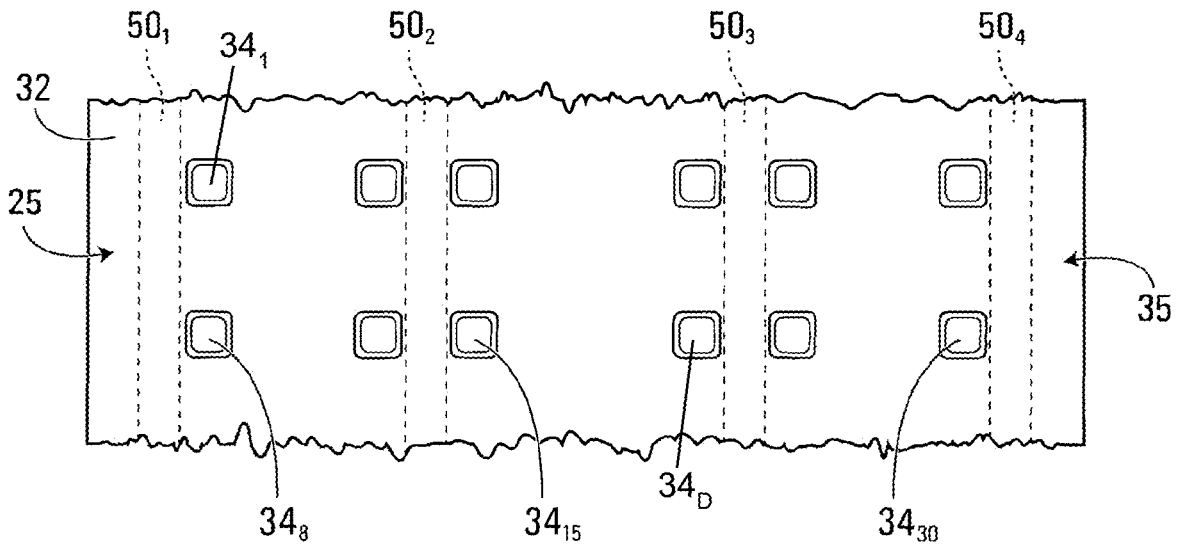

FIG. 5

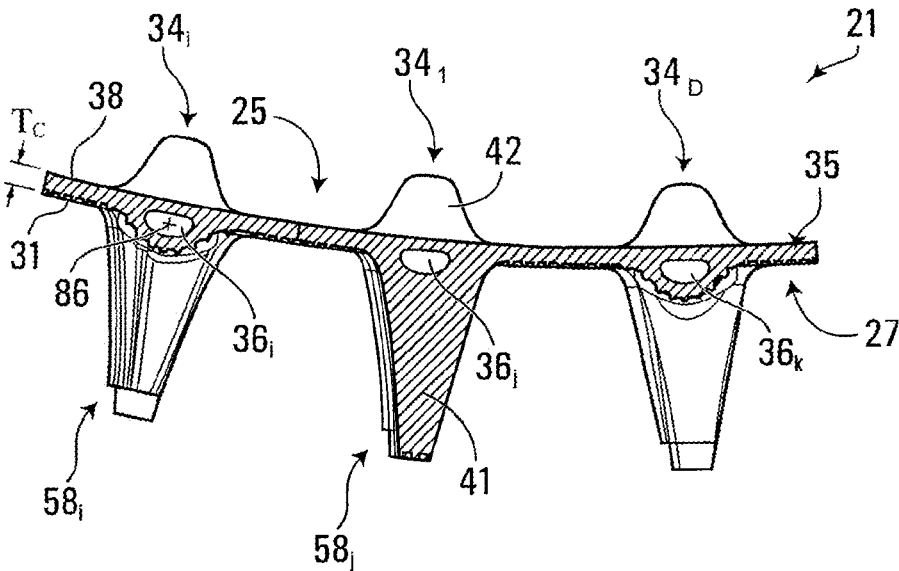

FIG. 6

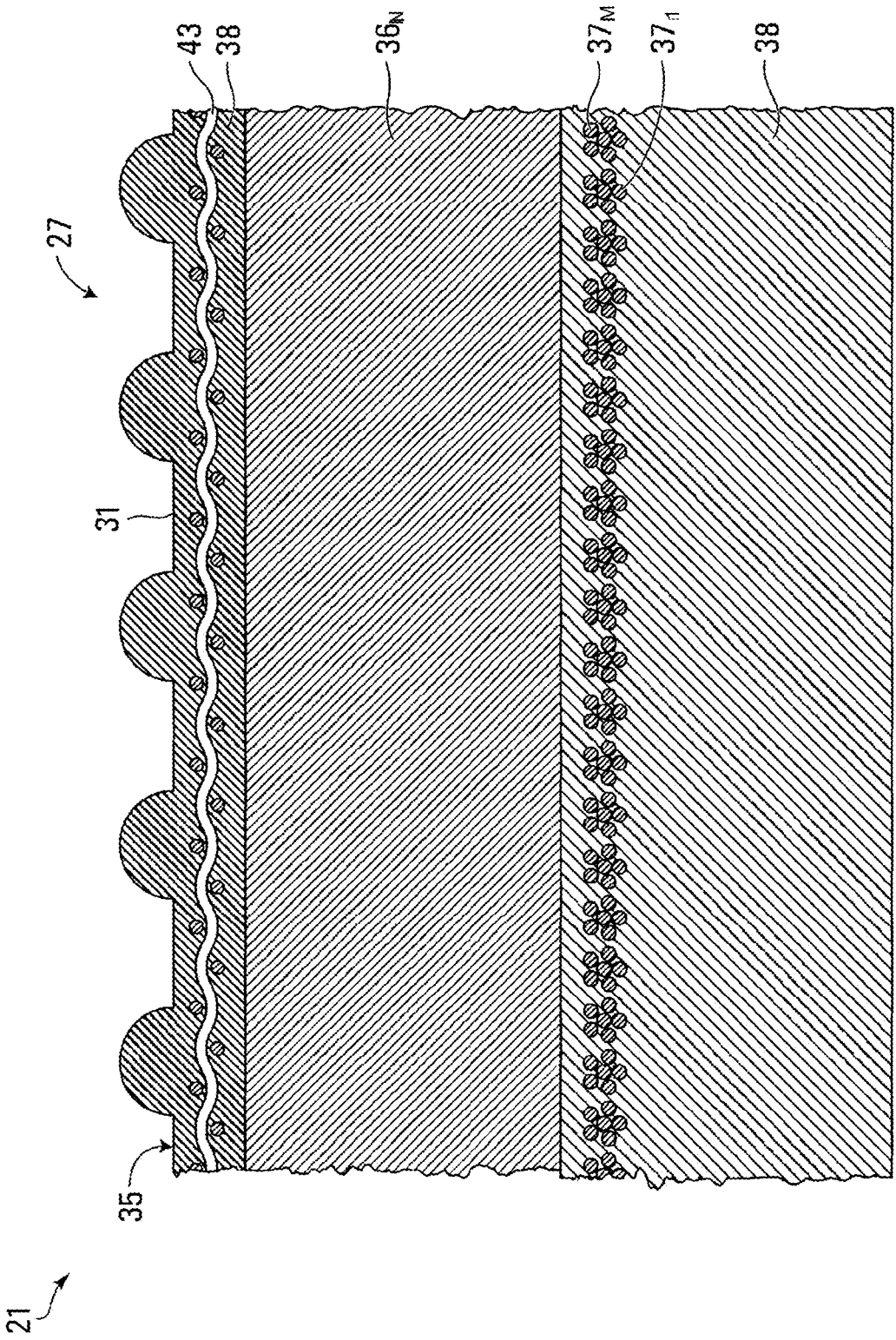

FIG. 7A

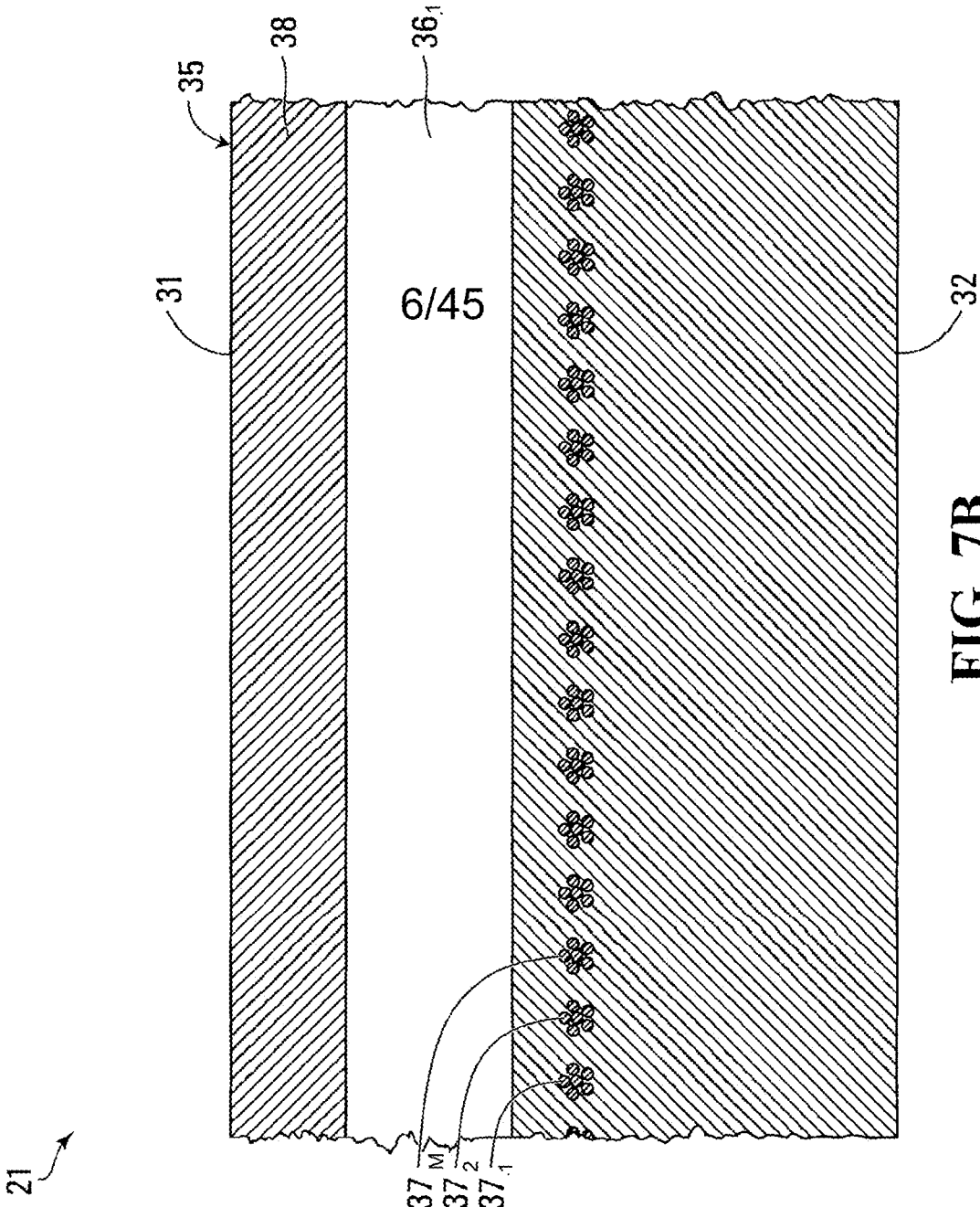

FIG. 7B

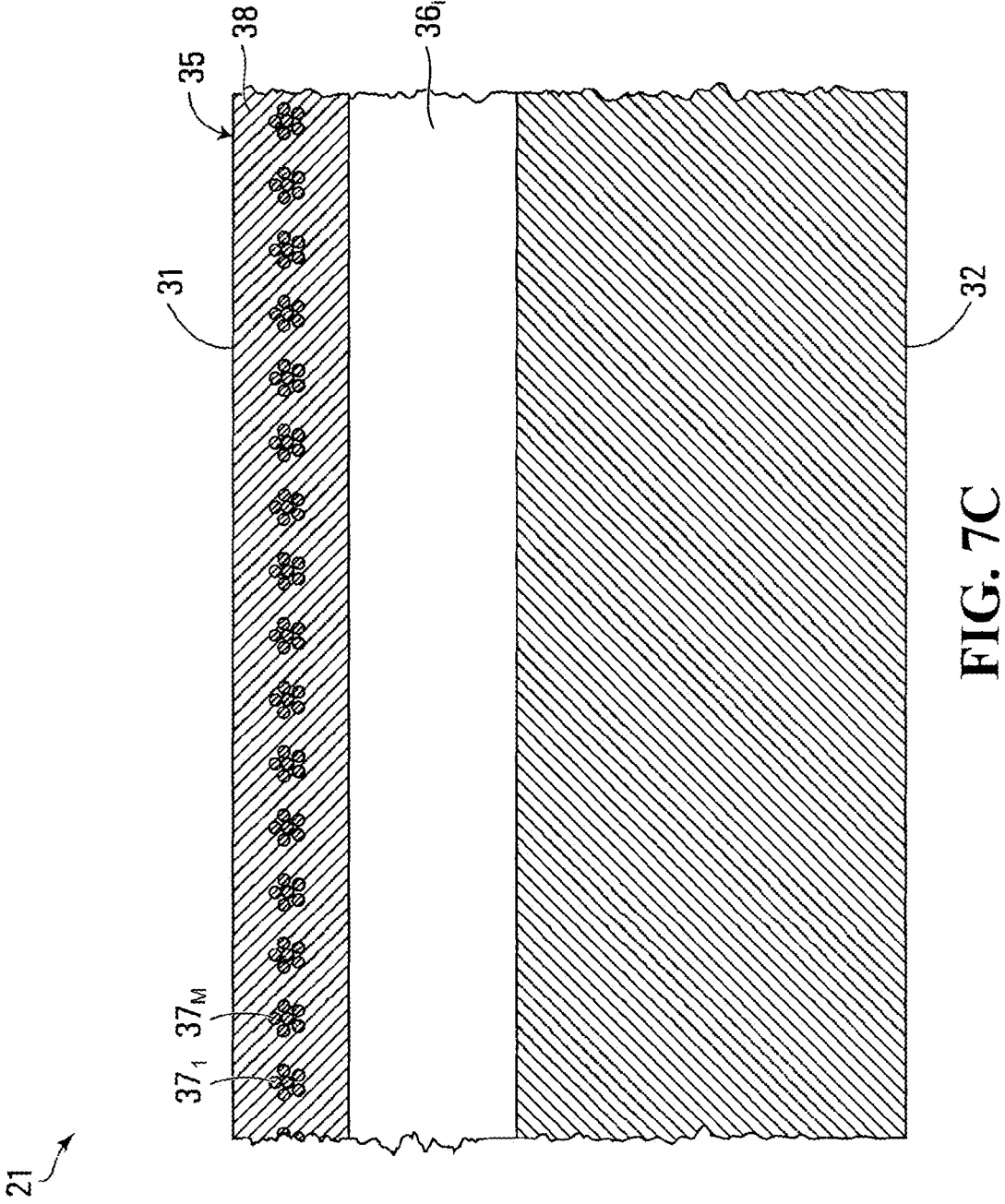

FIG. 7C

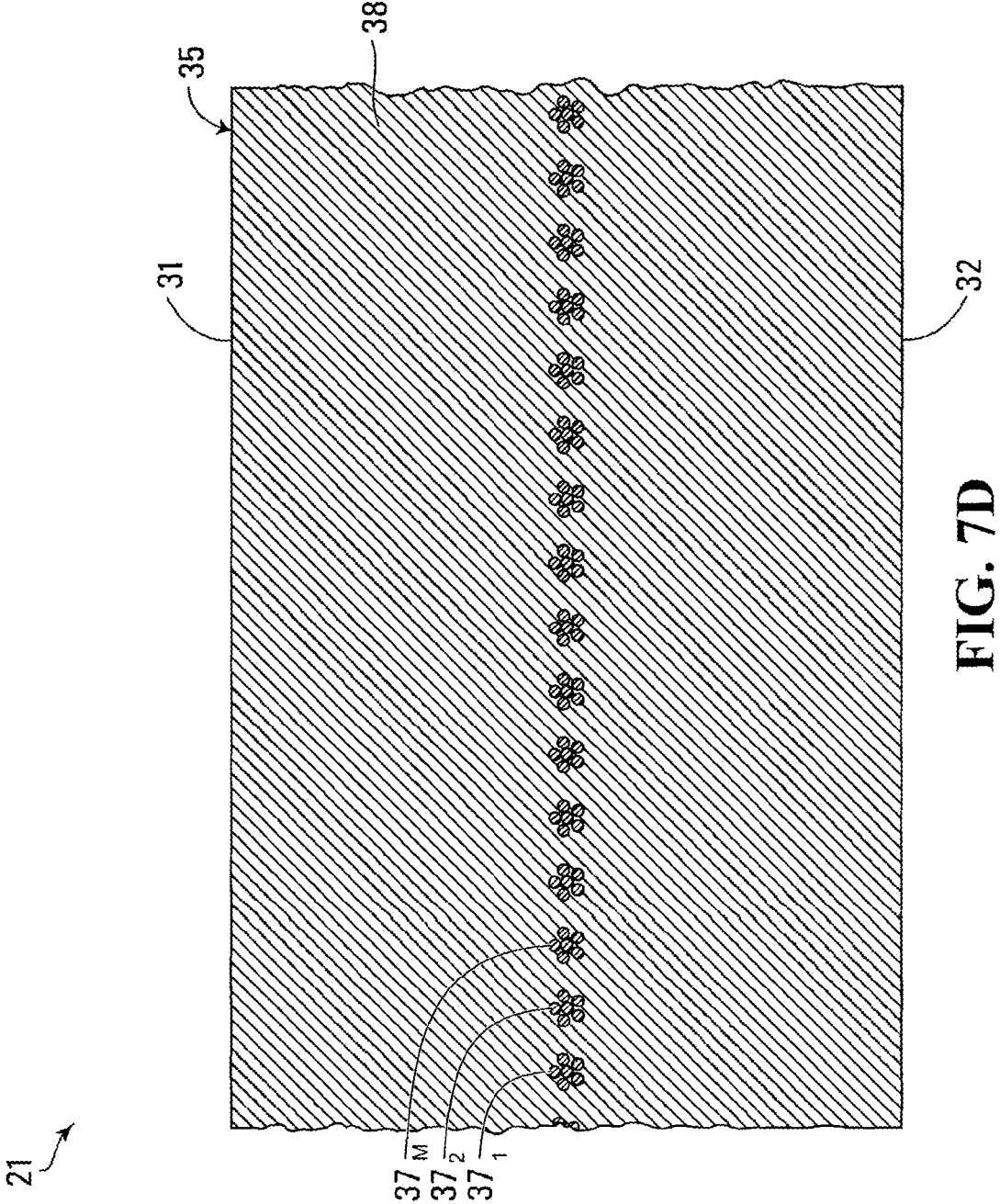

FIG. 7D

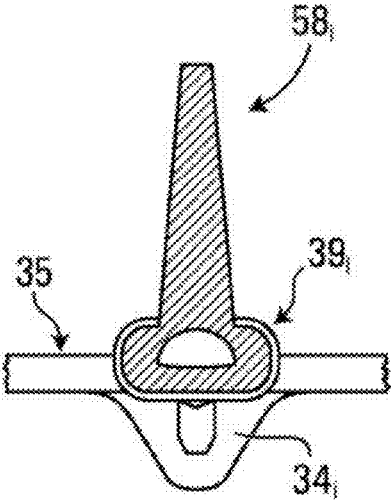

FIG. 8

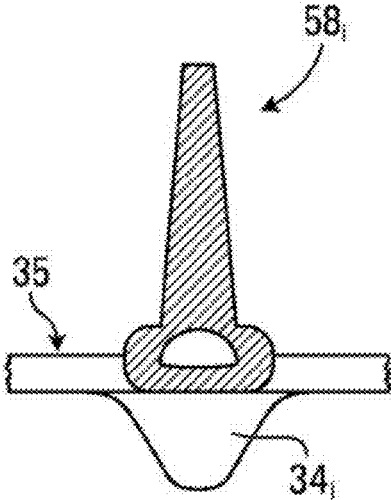

FIG. 9

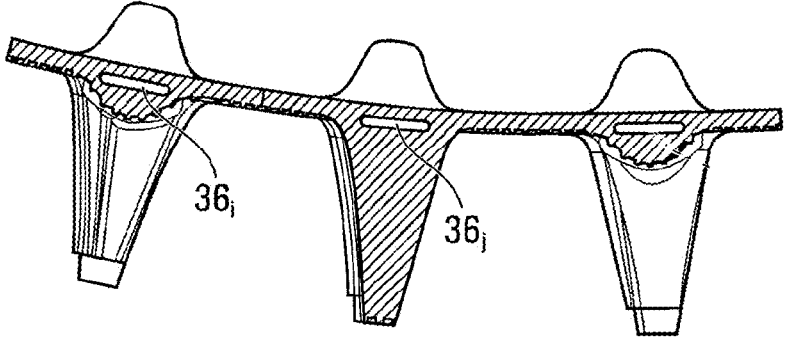

FIG. 10

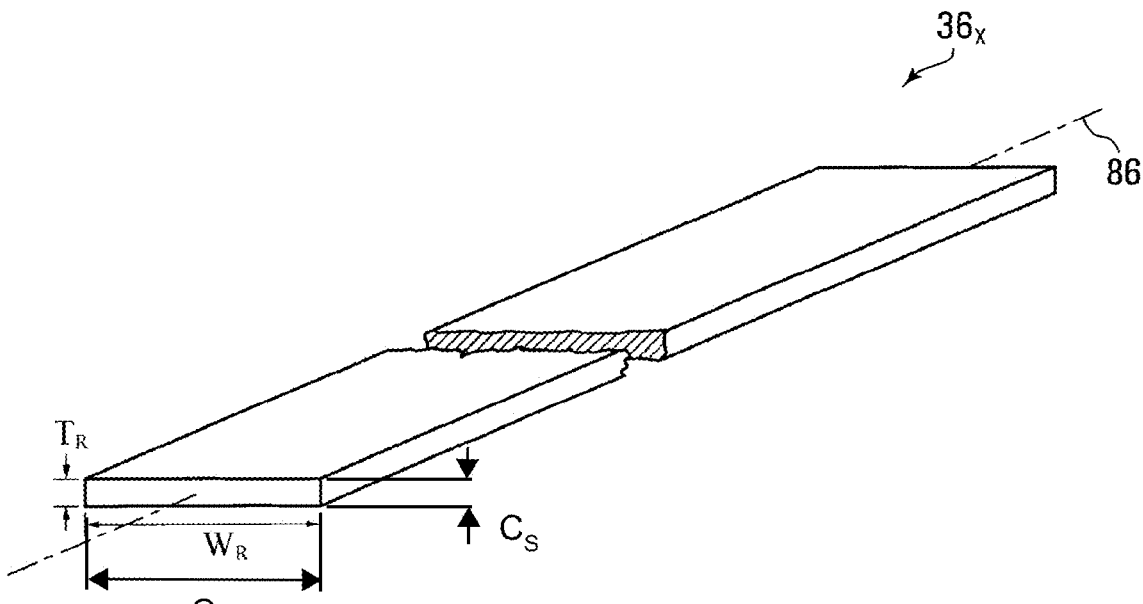

FIG. 11

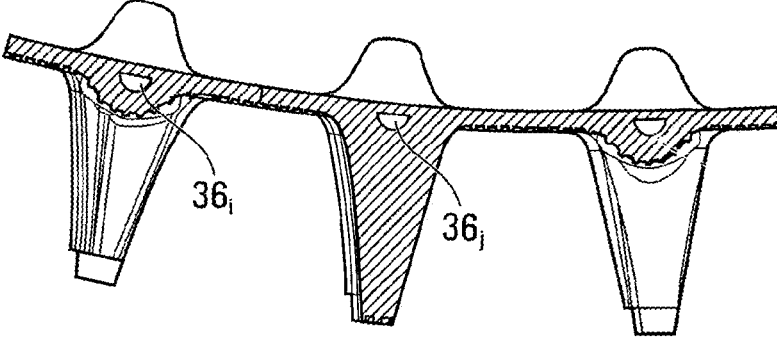

FIG. 12

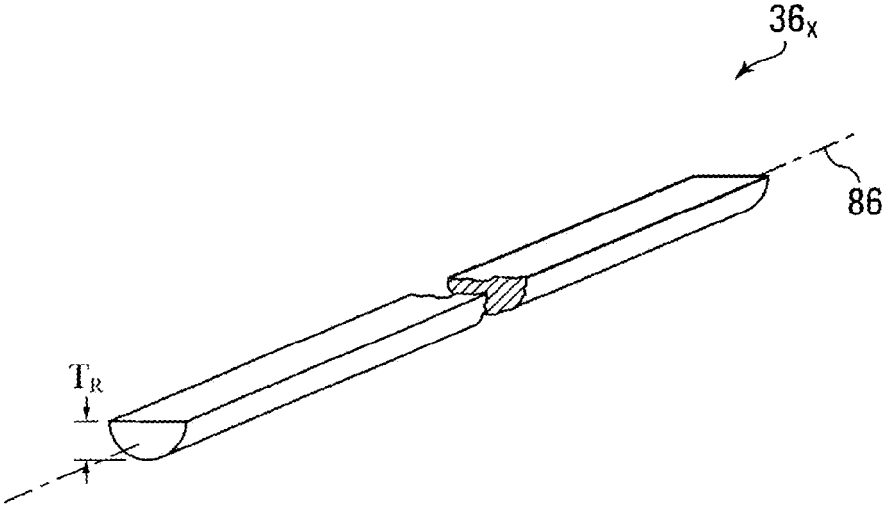

FIG. 13

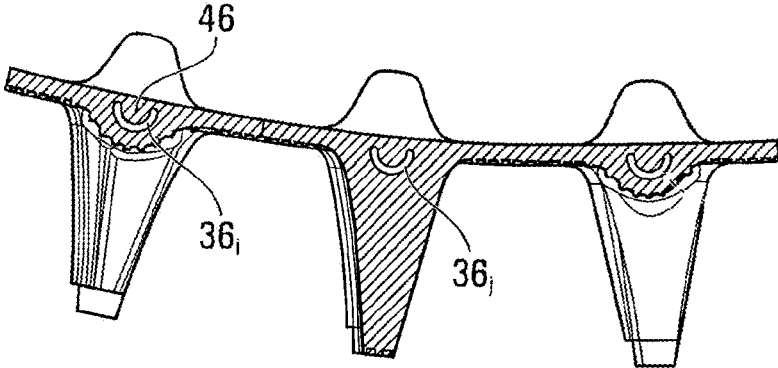

FIG. 14

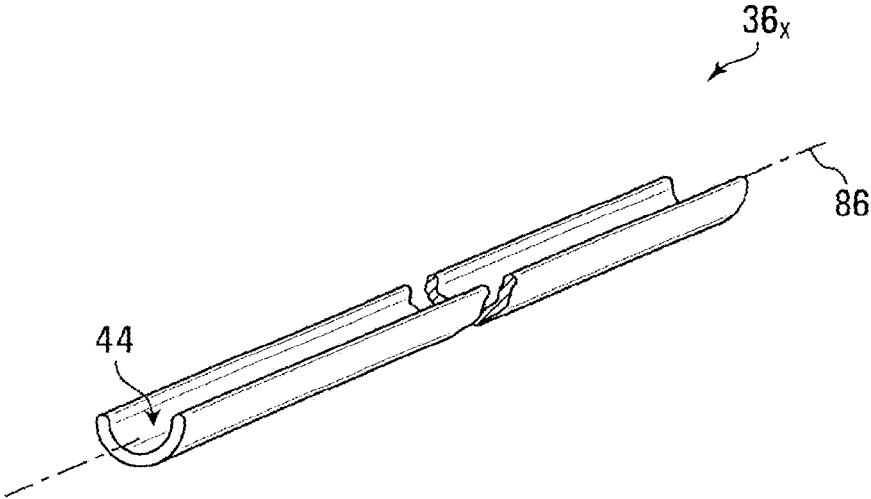

FIG. 15

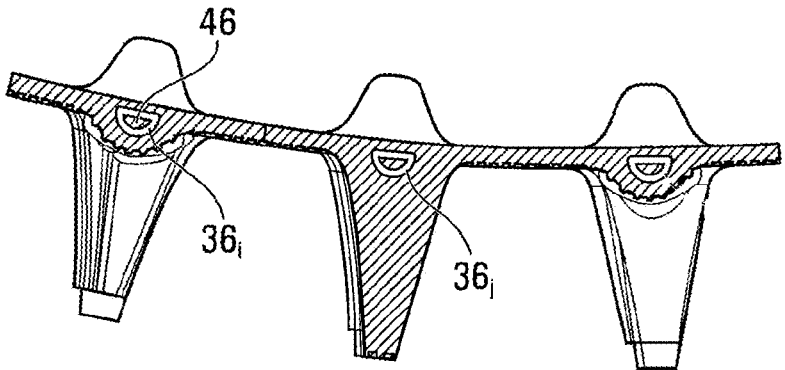

FIG. 16

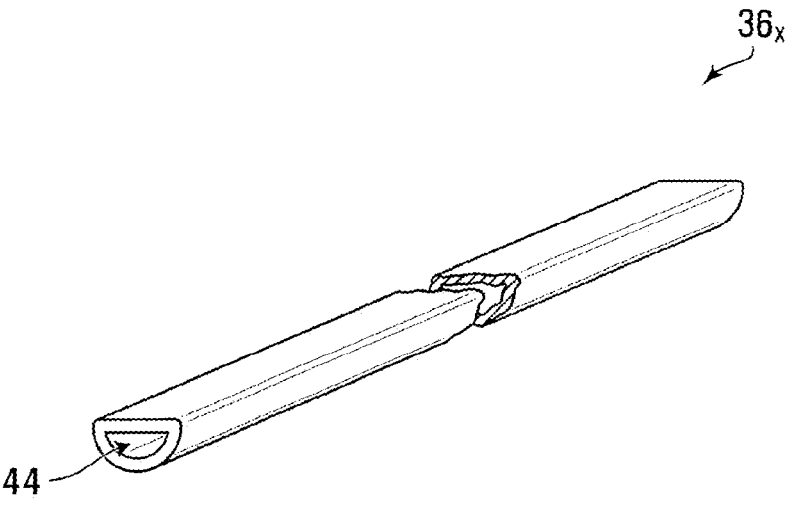

FIG. 17

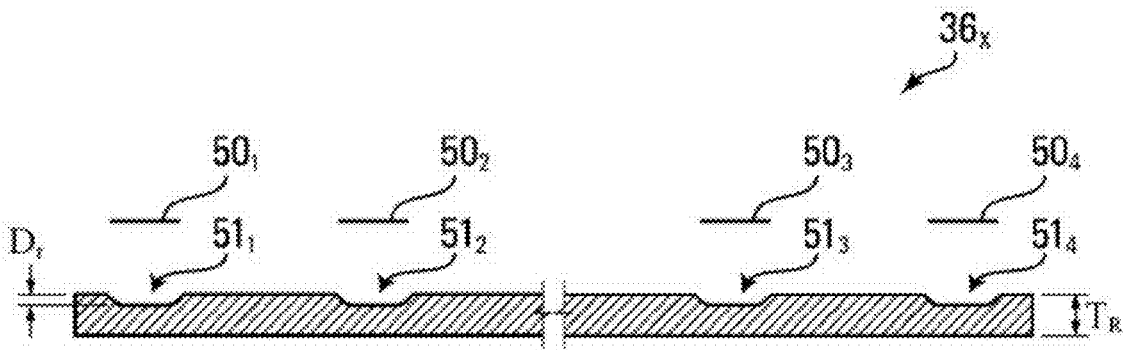

FIG. 18

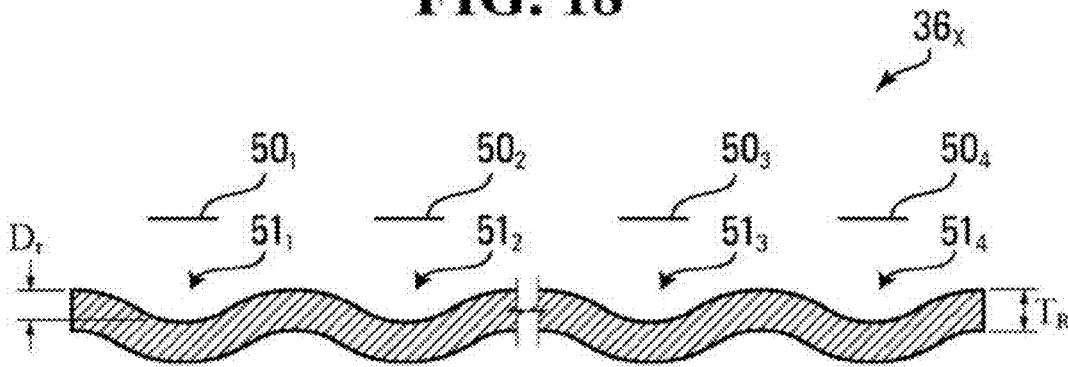

FIG. 19

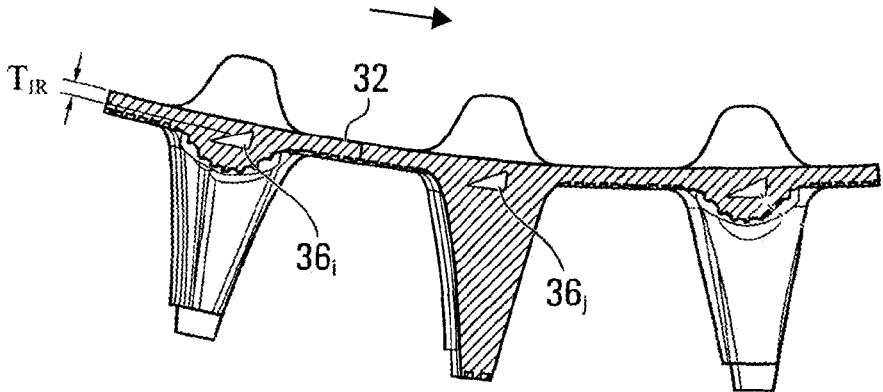

FIG. 20A

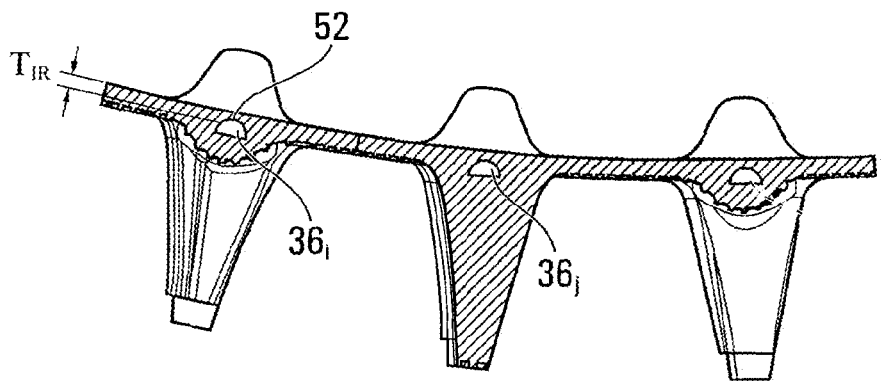

FIG. 20B

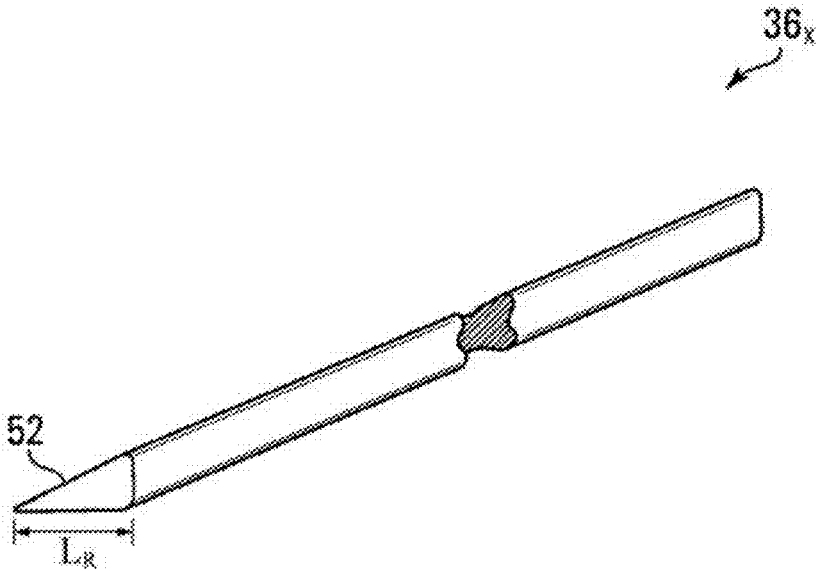

FIG. 21

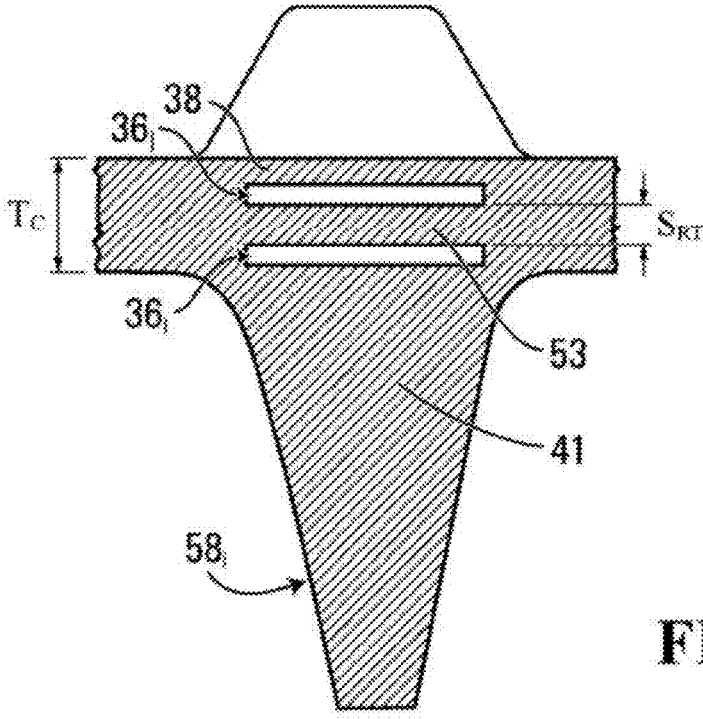

FIG. 22A

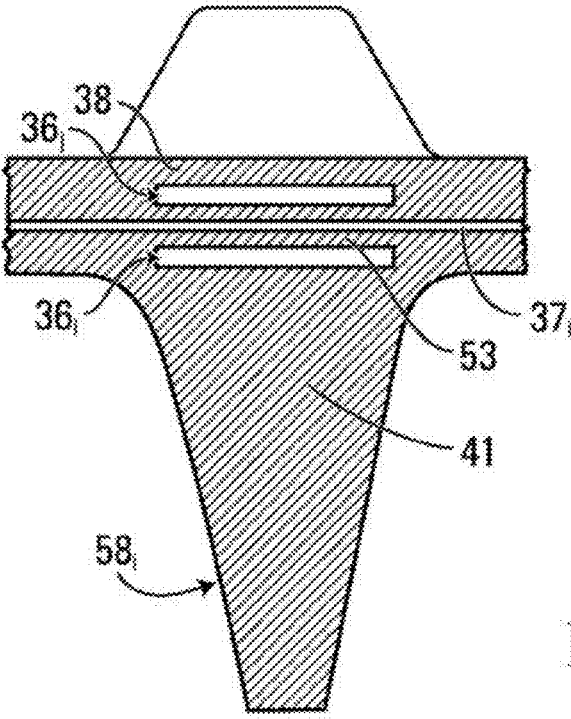

FIG. 22B

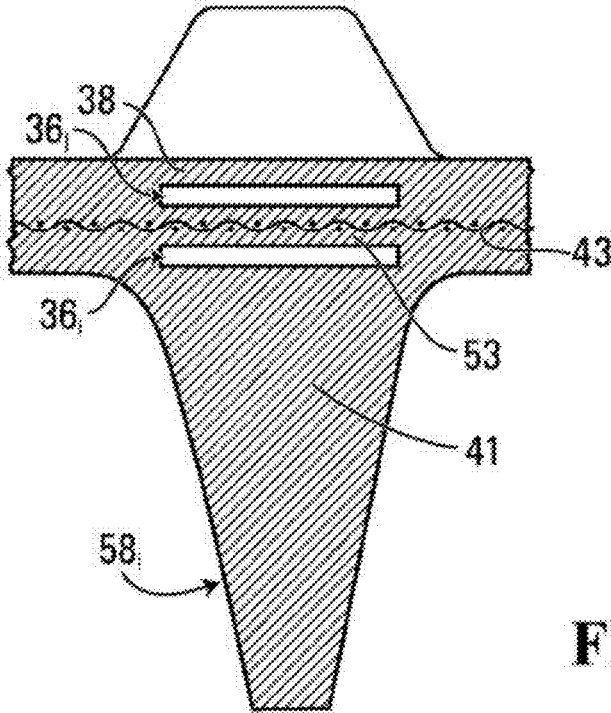

FIG. 22C

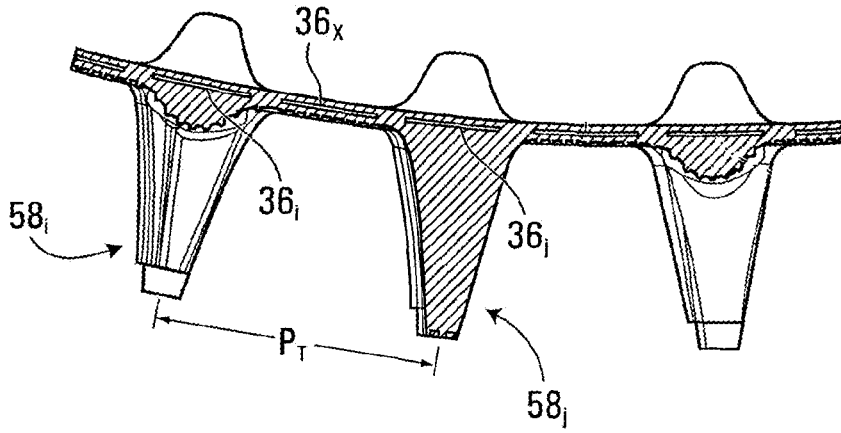

FIG. 23A

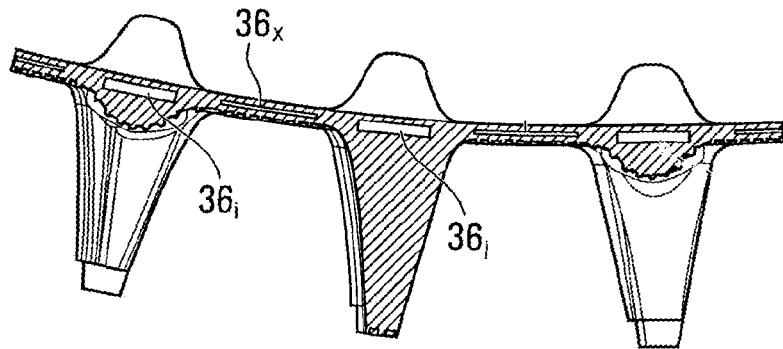

FIG. 23B

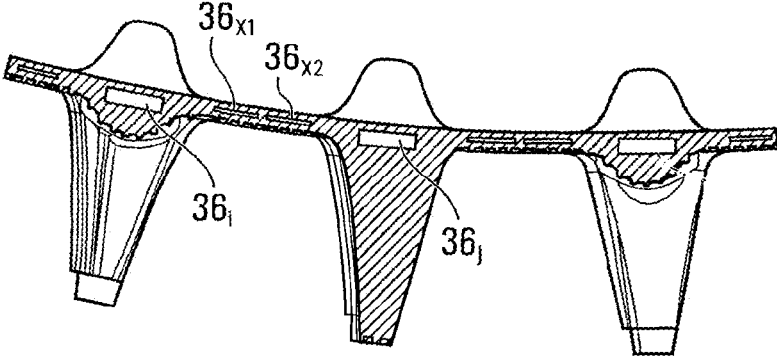

FIG. 24

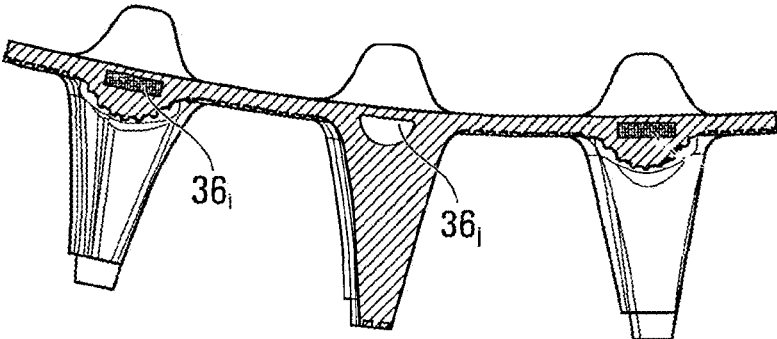

FIG. 25

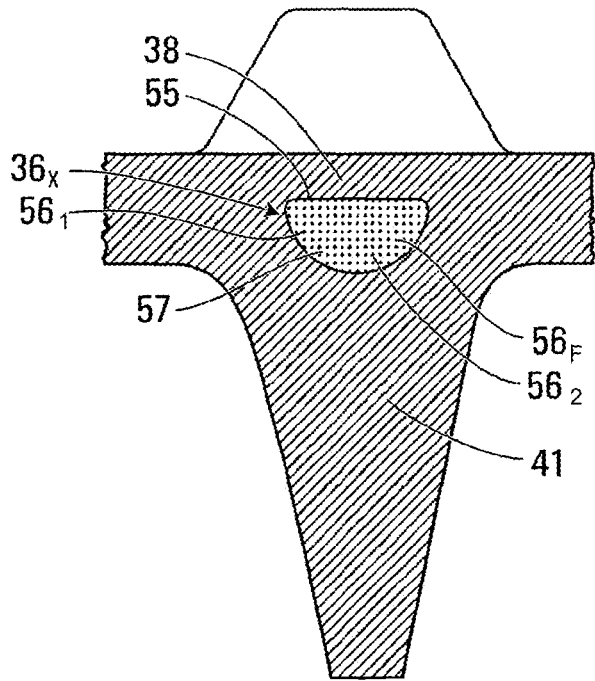

FIG. 26

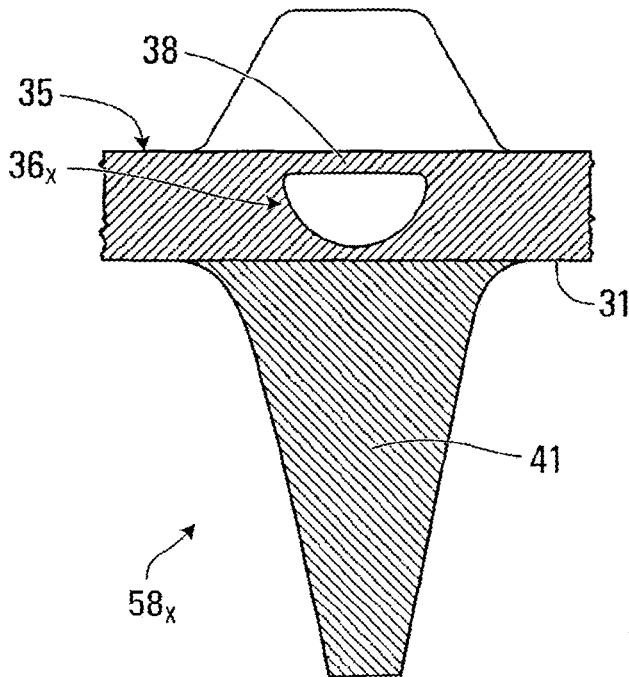

FIG. 27

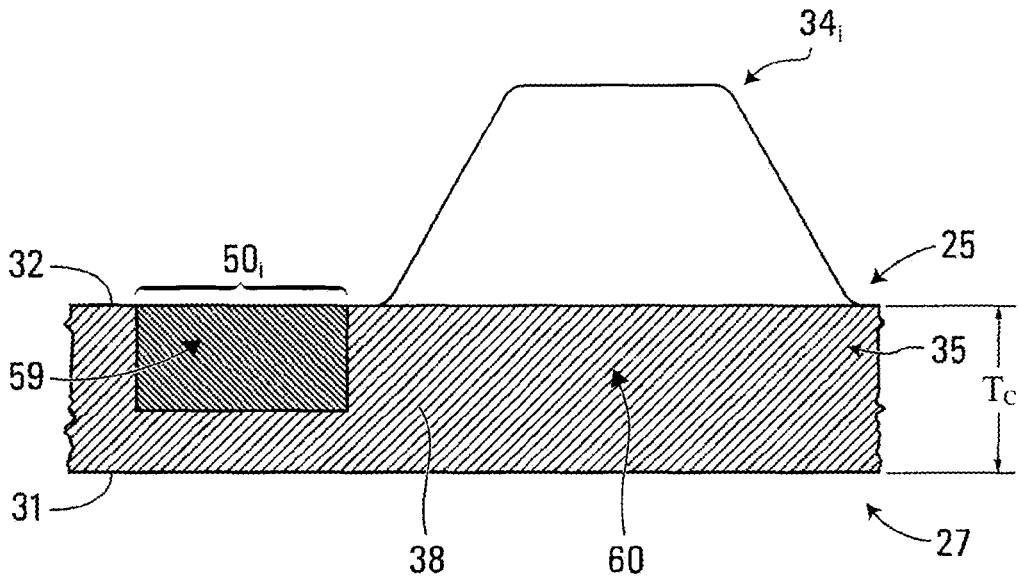

FIG. 28

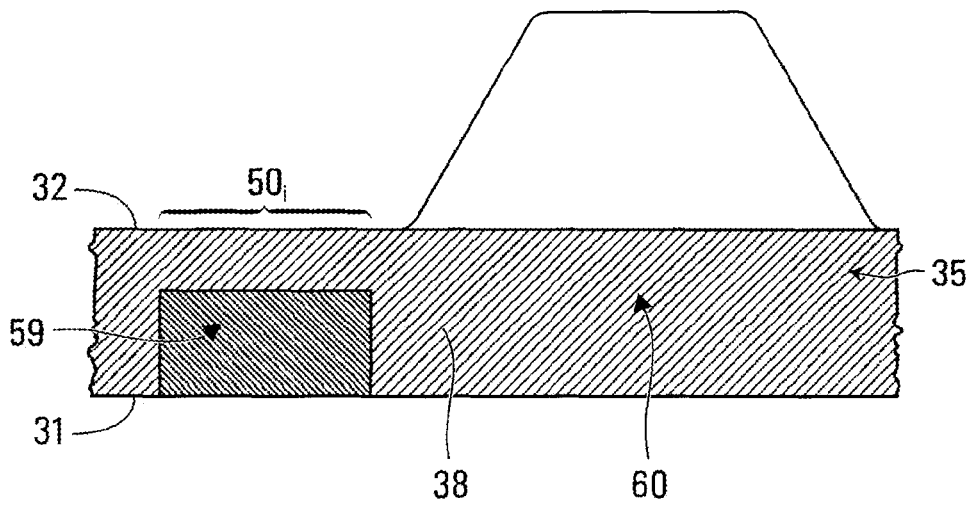

FIG. 29

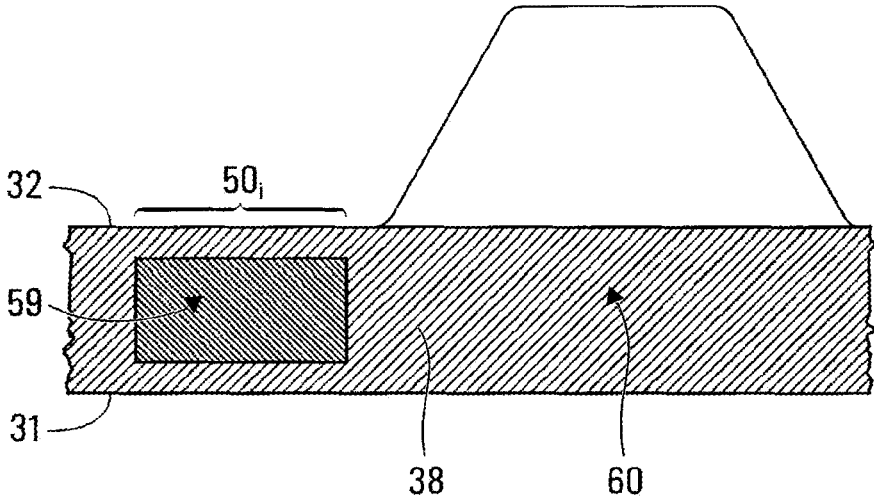

FIG. 30

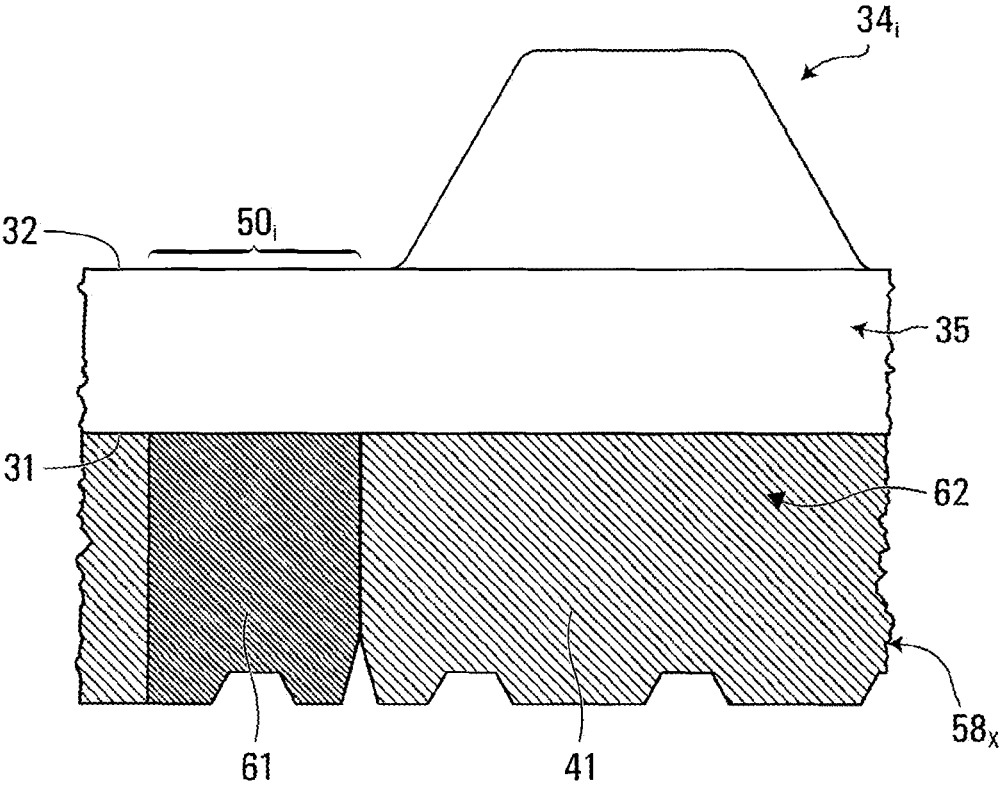

FIG. 31

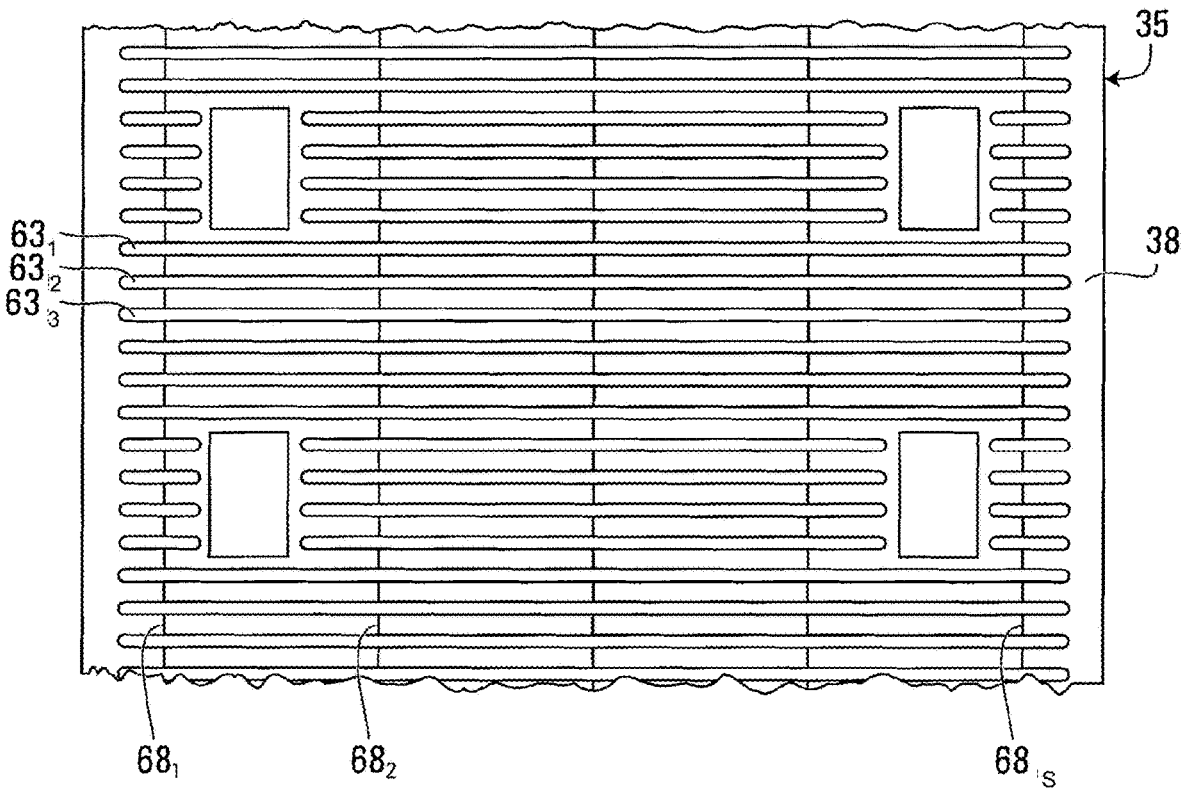

FIG. 32A

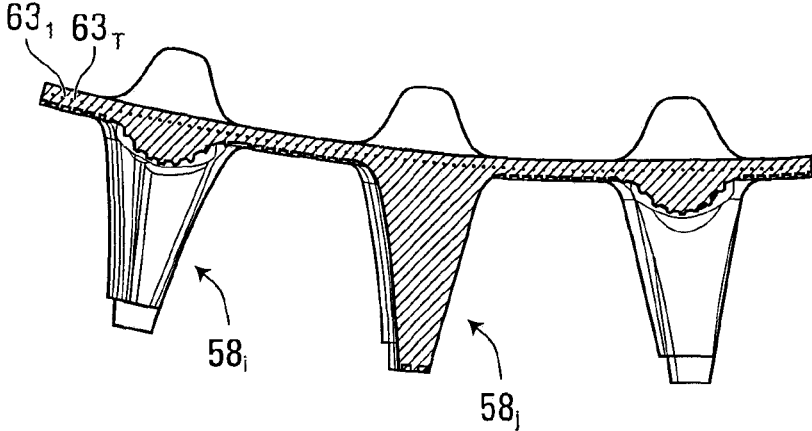

FIG. 32B

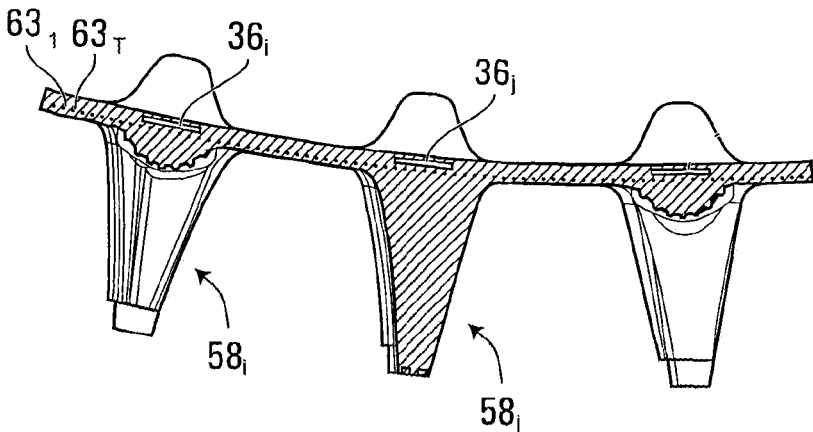

FIG. 32C

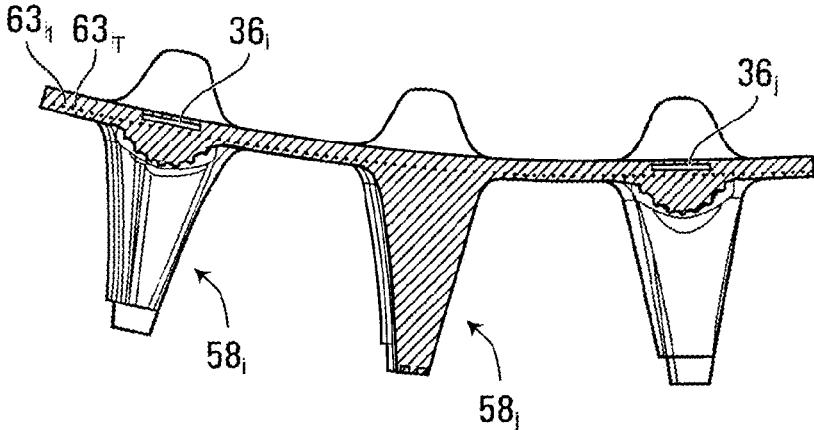

FIG. 32D

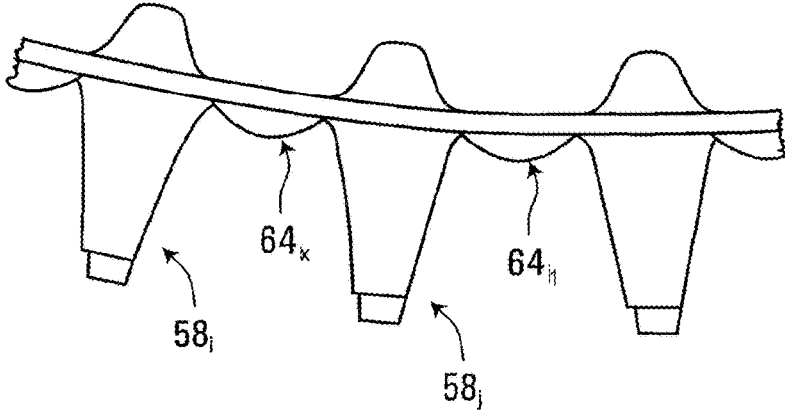

FIG. 33A

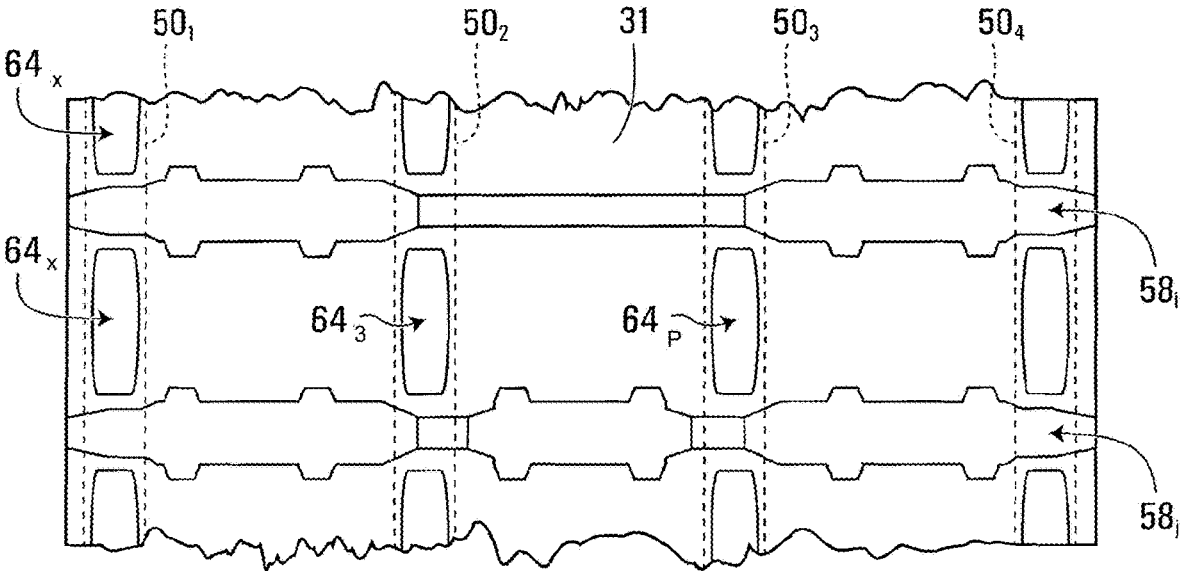

FIG. 33B

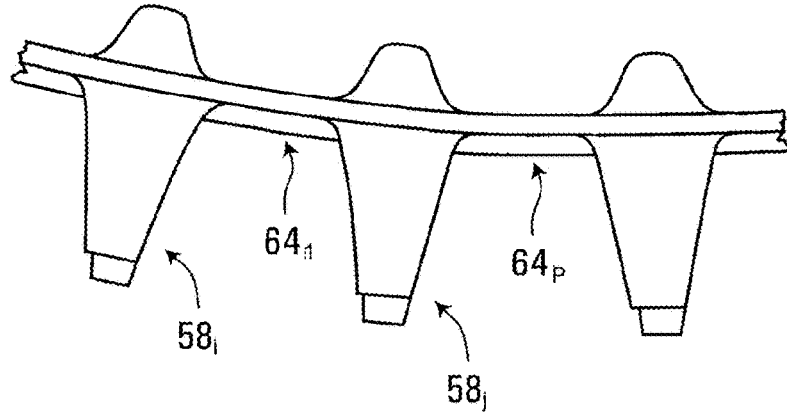

FIG. 34A

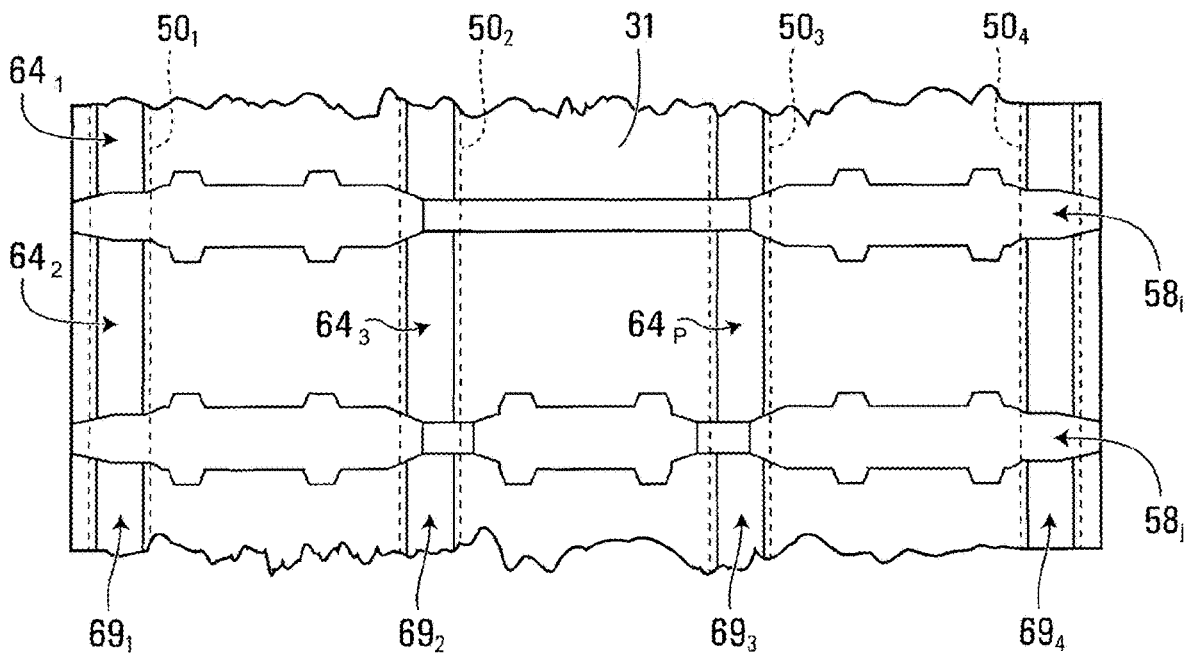

FIG. 34B

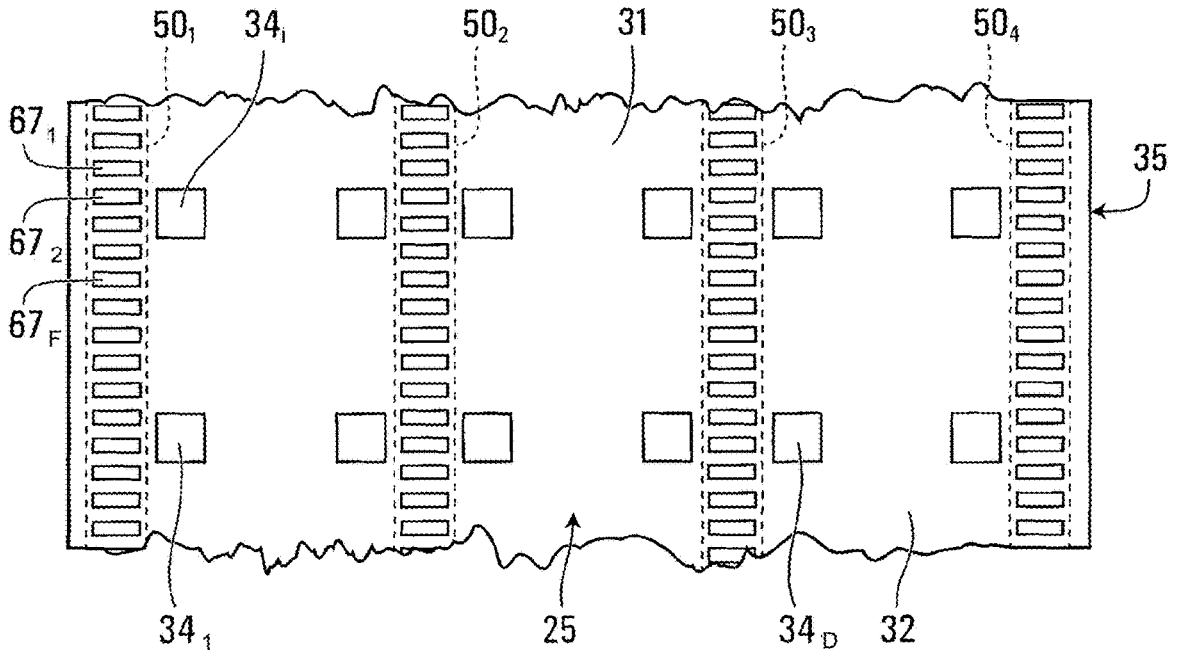

FIG. 35

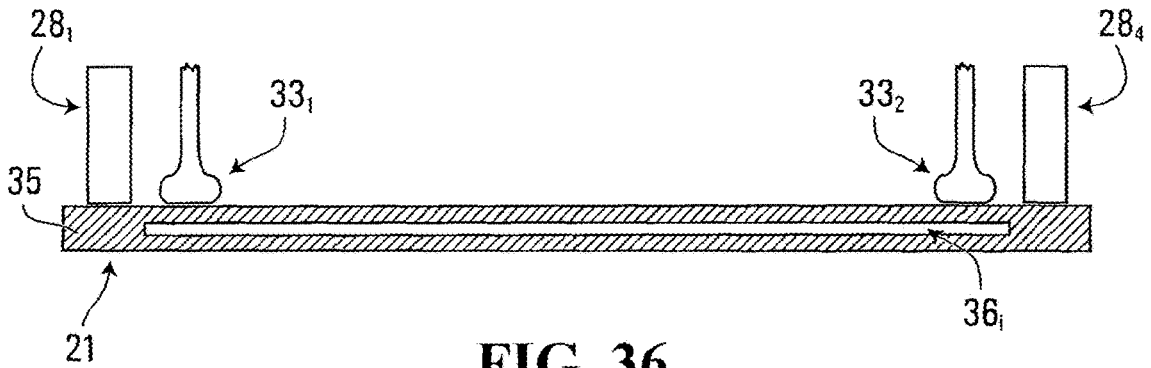

FIG. 36

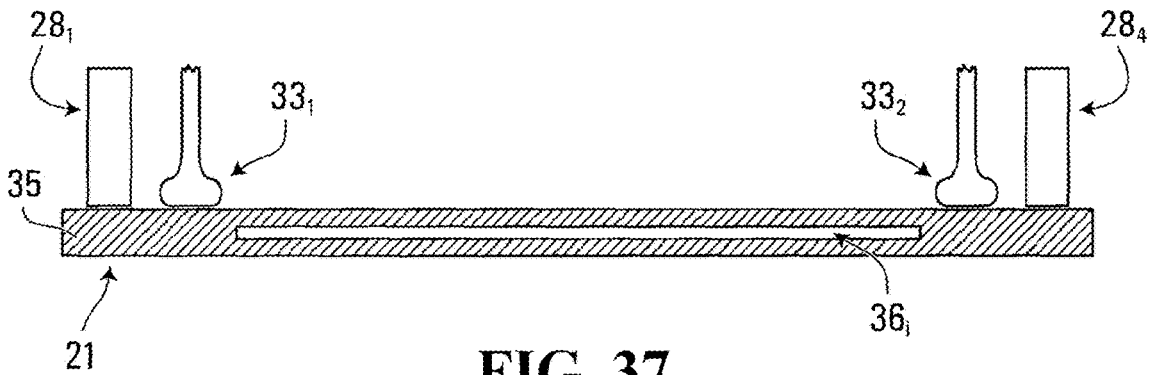

FIG. 37

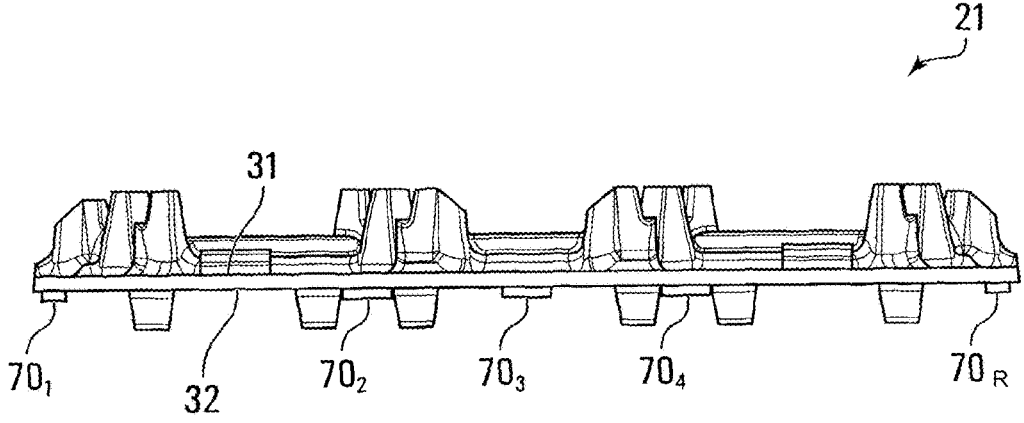

FIG. 38

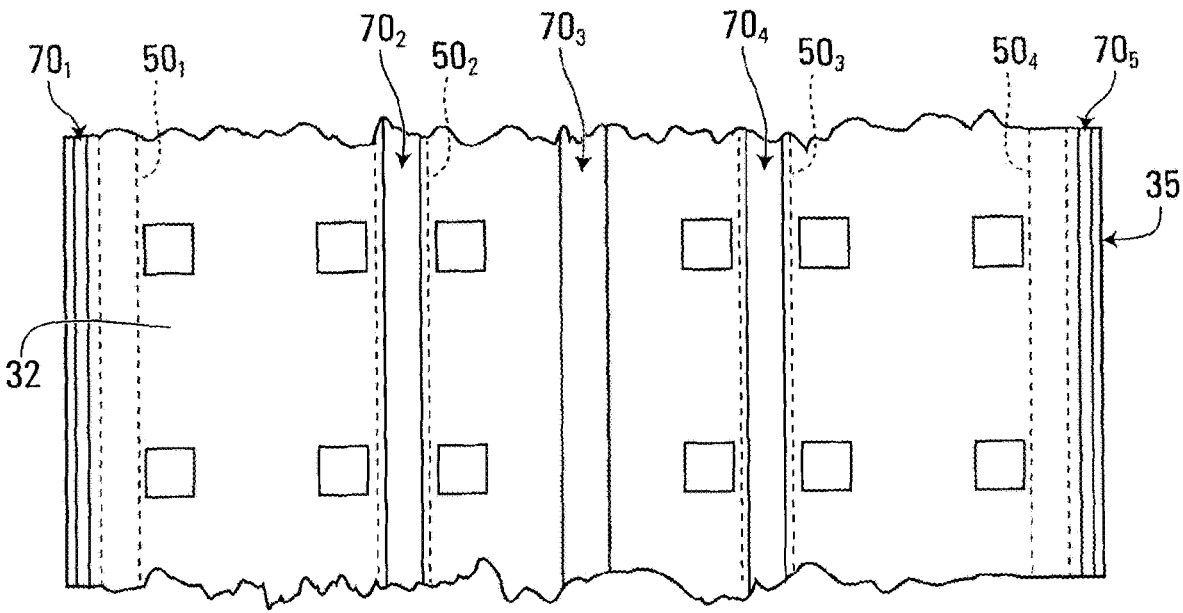

FIG. 39

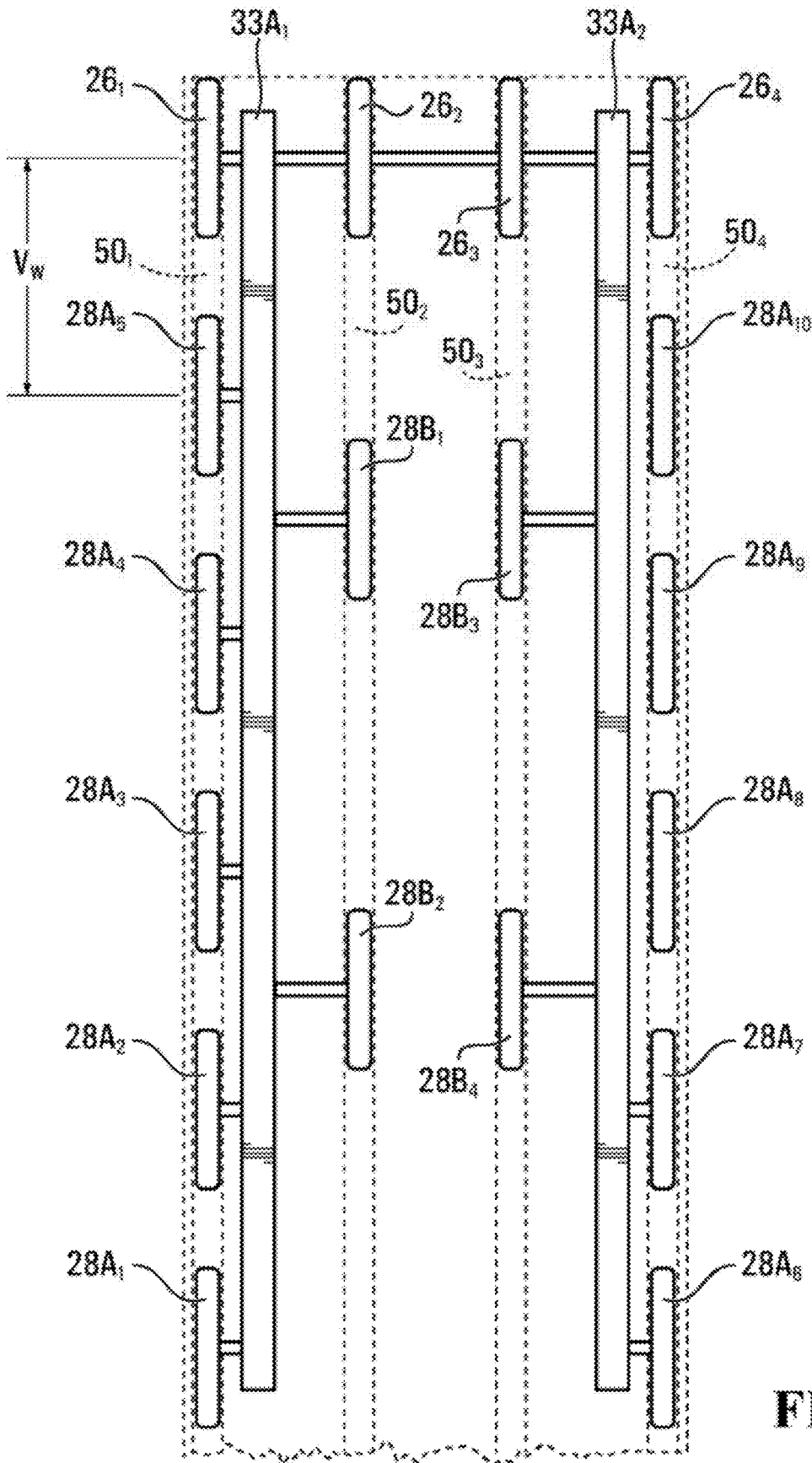

FIG. 40

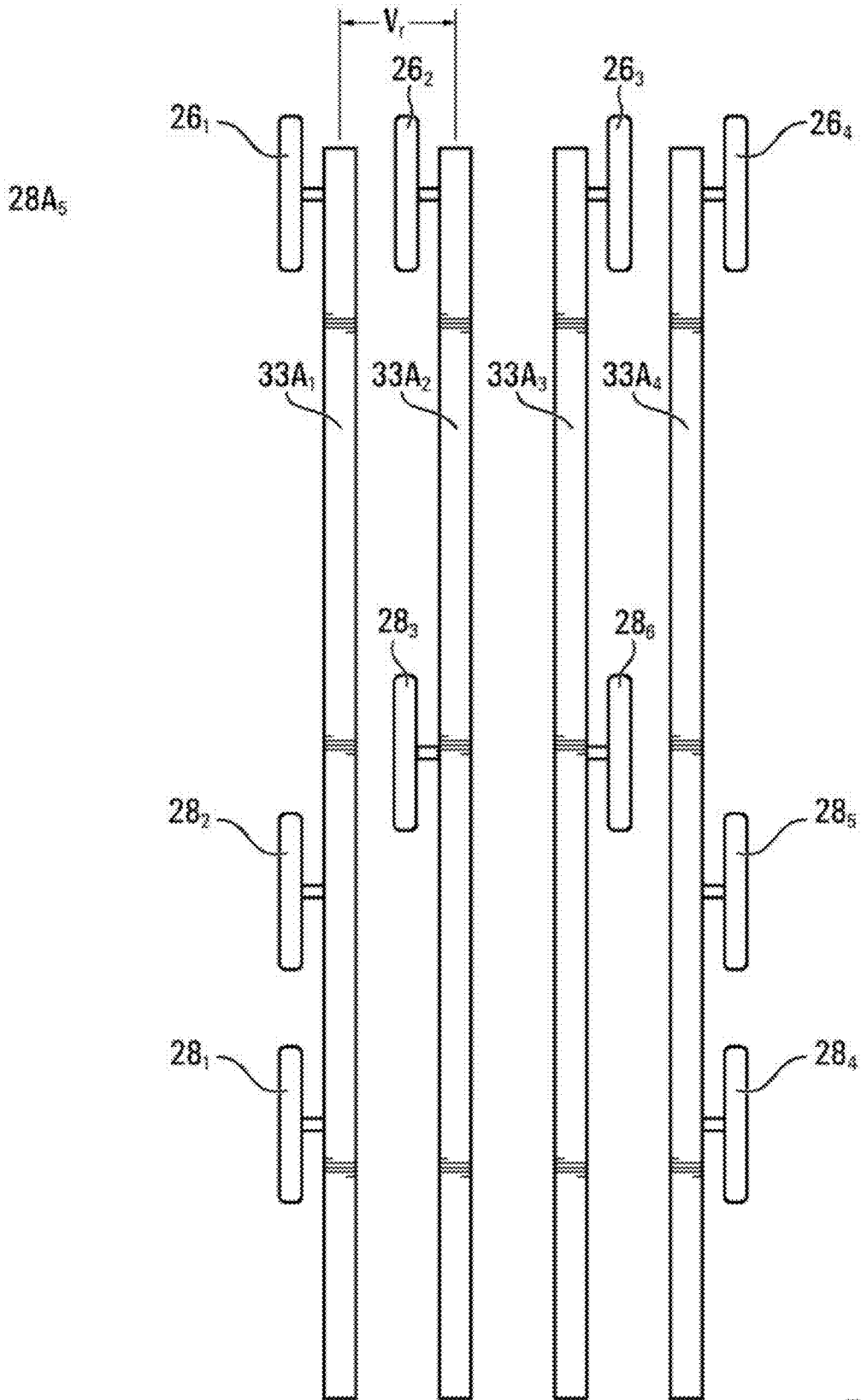

FIG. 41

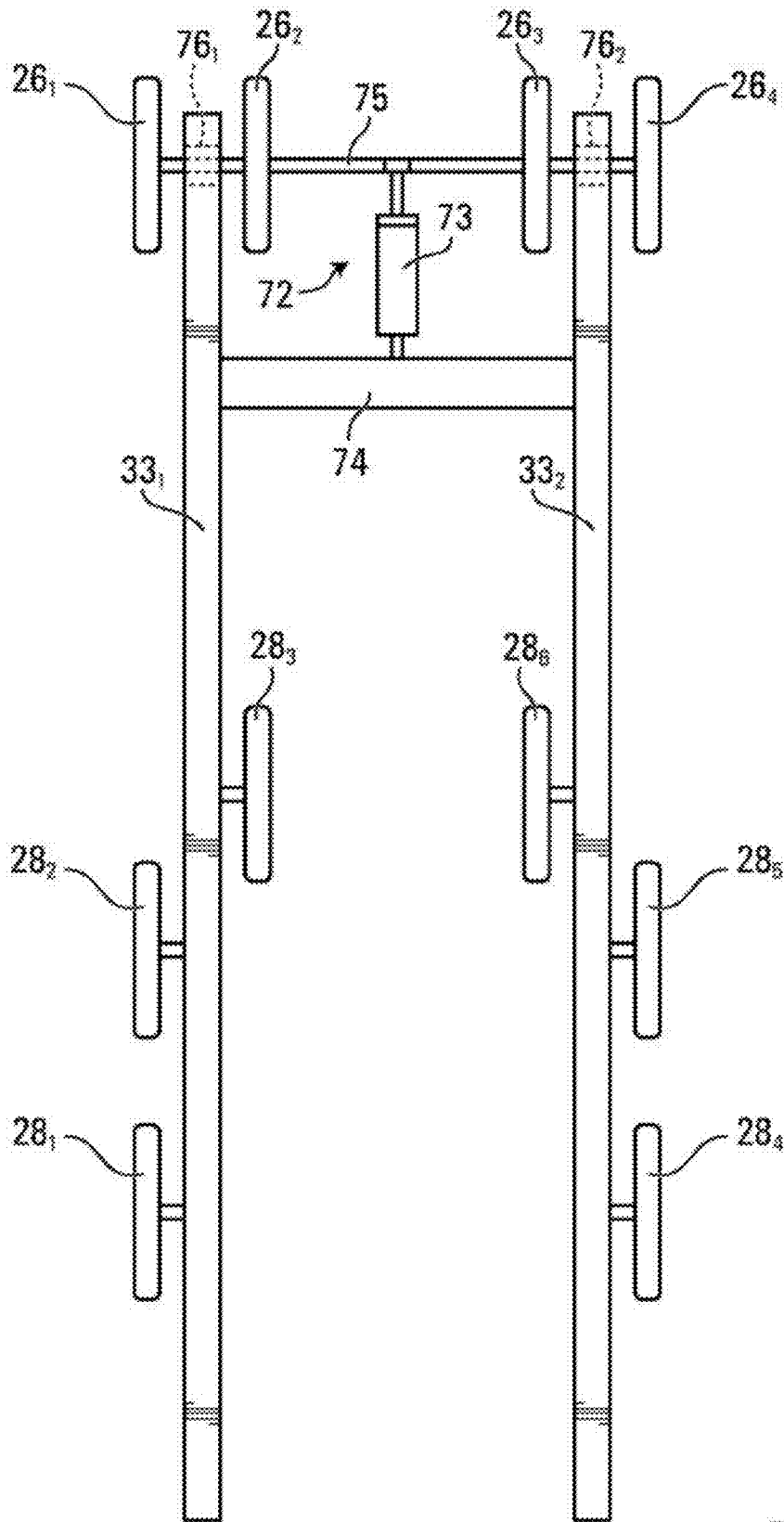

FIG. 42

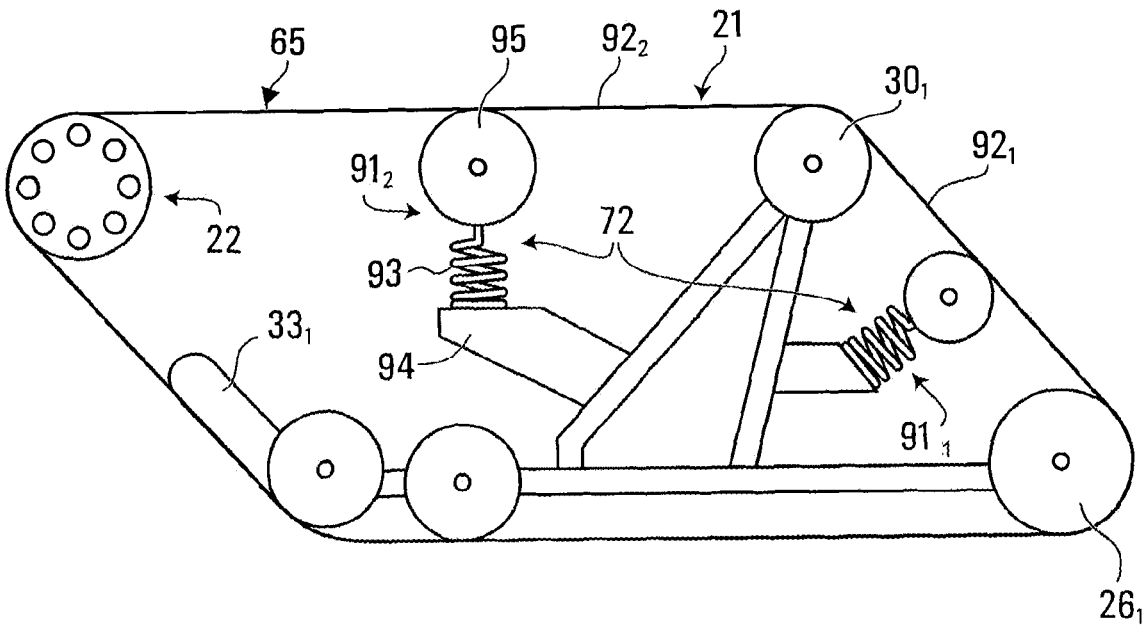

FIG. 43

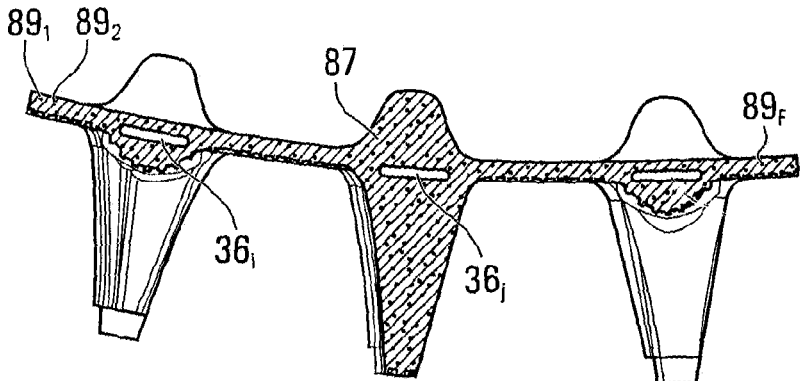

FIG. 44

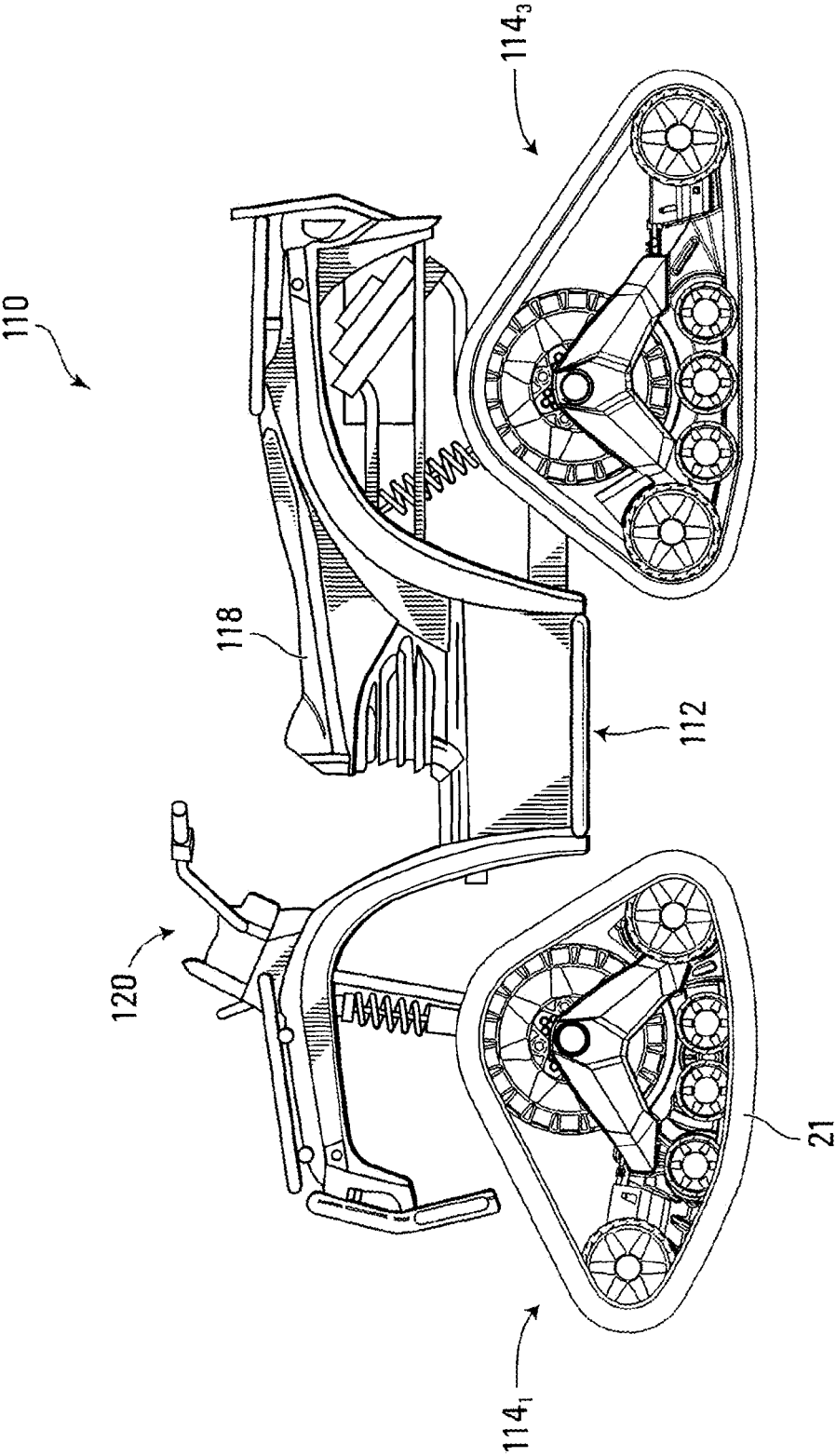

FIG. 45A

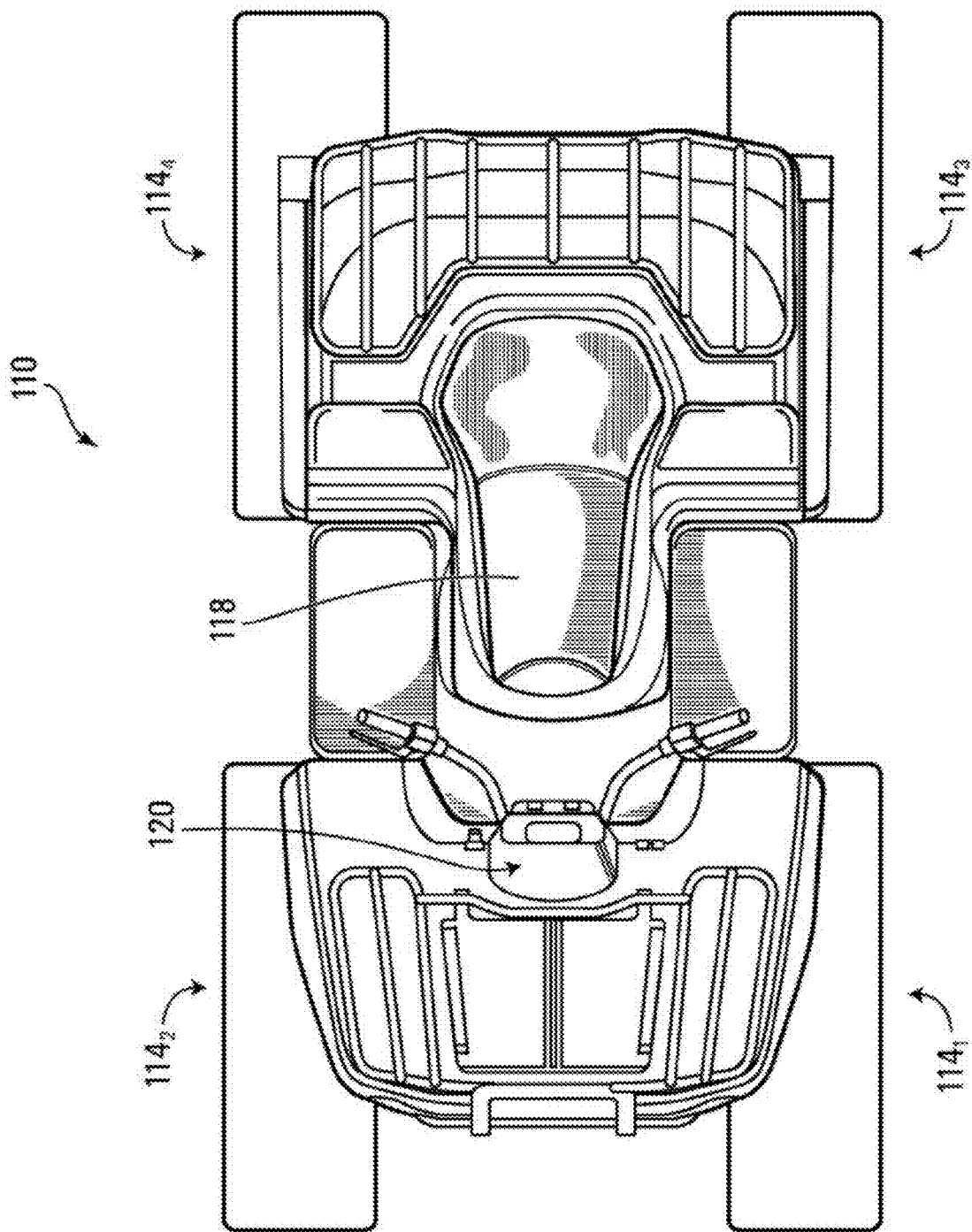

FIG. 45B

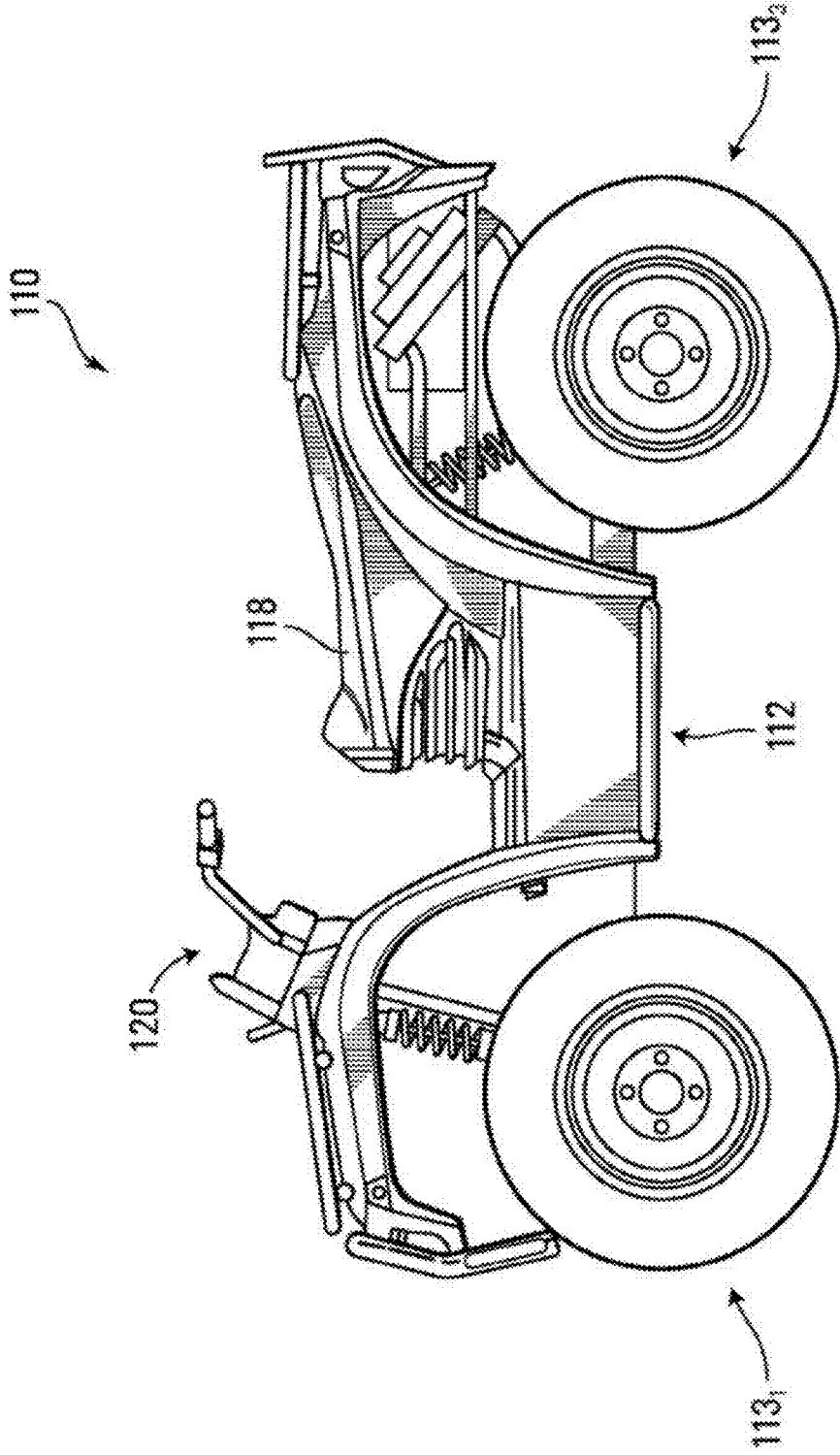

FIG. 46A

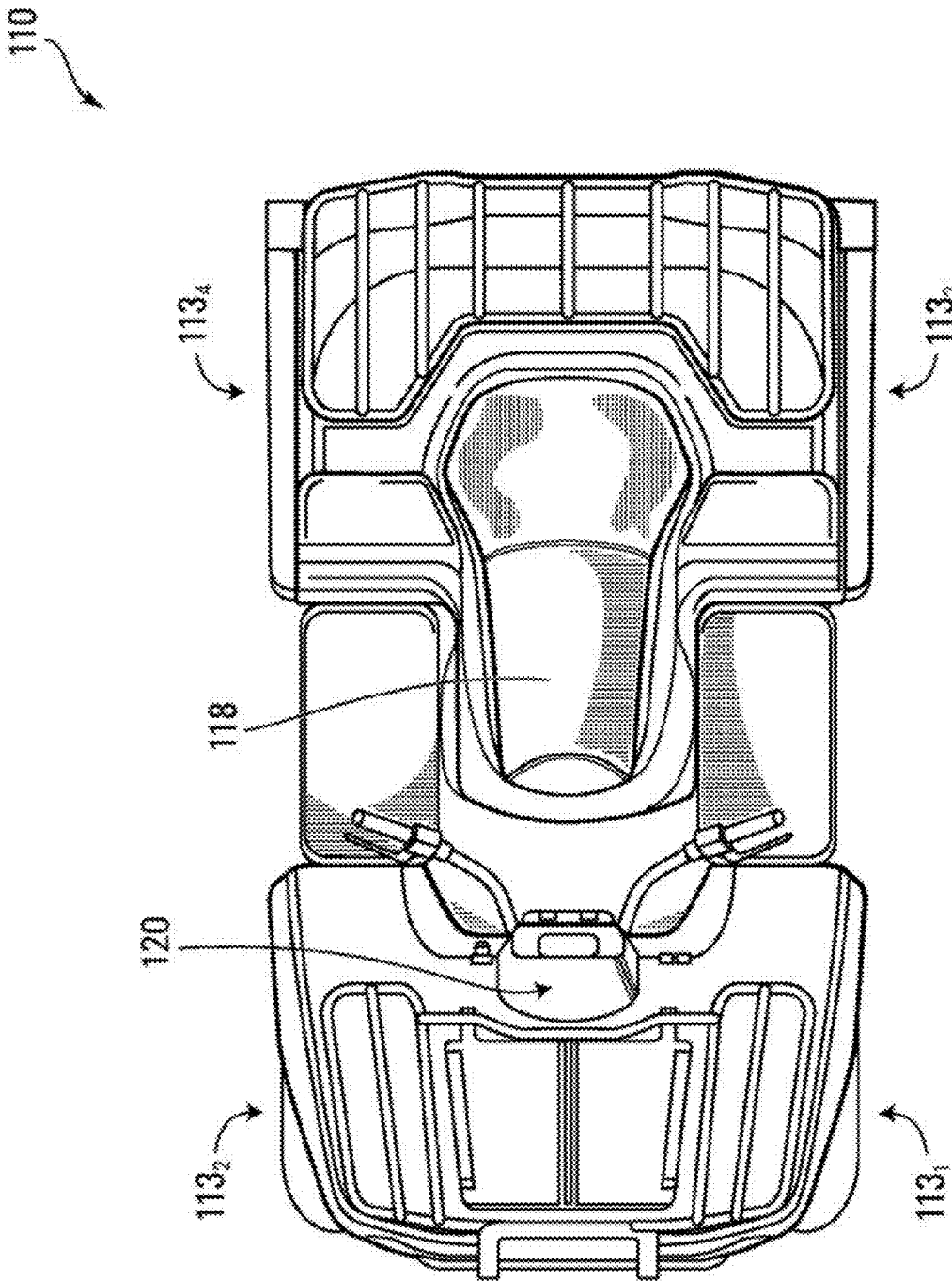

FIG. 46B

**TRACK SYSTEM FOR TRACTION OF AN
OFF-ROAD VEHICLE SUCH AS A
SNOWMOBILE OR AN ALL-TERRAIN
VEHICLE (ATV)**

CROSS-REFERENCE TO RELATED
APPLICATION

[0001] This application is a continuation application of, and claims benefit and priority to U.S. application Ser. No. 17/021,866 filed on Sep. 15, 2020; which is a continuation application of and claims benefit and priority to U.S. application Ser. No. 13/689,128 filed on Nov. 29, 2012 (now abandoned); which claims the benefit and priority of U.S. Provisional Patent Application 61/564,630 filed on Nov. 29, 2011. Each application is incorporated by reference herein.

FIELD OF THE INVENTION

[0002] The invention relates generally to off-road vehicles such as snowmobiles and all-terrain vehicles (ATV) and, more particularly, to track systems for traction of snowmobiles, ATVs and other off-road vehicles.

BACKGROUND

[0003] Snowmobiles allow efficient travel on snowy and in some cases icy grounds. A snowmobile comprises a track system which engages the ground to provide traction. The track system comprises a track-engaging assembly and an endless track that moves around the track-engaging assembly and engages the ground to generate traction. The endless track typically comprises an elastomeric body in which are embedded certain reinforcements, such as transversal stiffening rods providing transversal rigidity to the track, longitudinal cables providing tensional strength, and/or fabric layers. The track-engaging assembly comprises wheels and in some cases slide rails around which the endless track is driven.

[0004] Various considerations are important when it comes to a snowmobile's use and performance.

[0005] For example, a snowmobile generates noise, including noise generated by its track system. Various factors may contribute to the noise generated by the snowmobile's track system. For instance, in some cases: impacts between roller and/or other wheels of the track-engaging assembly and the transversal stiffening rods of the endless track; impacts between the slide rails and the transversal stiffening rods of the endless track; impacts between the slide rails and slide members (e.g., "clips") of the endless track, if any; impacts between the ground and traction projections of a ground-engaging outer side of the endless track; and contact between the endless track and drive wheels of the track-engaging assembly may contribute to the noise generated by the snowmobile's track system.

[0006] As another example, traction and floatation provided by a snowmobile's track system depend on rigidity of the track system's endless track. While longitudinal flexibility of the track is desirable in order to efficiently drive the track around the track-engaging assembly, transversal rigidity of the track is desirable in order to have a proper ground-contacting area for traction and floatation.

[0007] Similar considerations may be important for all-terrain vehicles (ATVs) equipped with track systems having endless tracks providing traction to the ATVs on the ground (e.g., an ATV equipped with two front track systems in place

of two front wheels and two rear track systems in place of two rear wheels) and/or for other types of off-road vehicles.

[0008] While certain developments have been made to improve performance of track systems of snowmobiles, ATVs and other off-road vehicles, there remains a need for improvements in such track systems.

SUMMARY OF THE INVENTION

[0009] In accordance with an aspect of the invention, there is provided a track for traction of an off-road vehicle. The track is mountable around a track-engaging assembly of the off-road vehicle. The track-engaging assembly comprises a drive wheel for driving the track. The track is elastomeric to be flexible around the track-engaging assembly. The track comprises an inner surface for facing the track-engaging assembly, a ground-engaging outer surface for engaging the ground, and a plurality of traction projections projecting from the ground-engaging outer surface.

[0010] The track also comprises a plurality of stiffening rods extending transversally to a longitudinal direction of the track. Each stiffening rod of the plurality of stiffening rods has a cross-section perpendicular to a longitudinal axis of the stiffening rod. The cross-section of the stiffening rod is elongate.

[0011] In accordance with another aspect of the invention, there is provided a track for traction of an off-road vehicle. The track is mountable around a track-engaging assembly of the off-road vehicle. The track-engaging assembly comprises a drive wheel for driving the track. The track is elastomeric to be flexible around the track-engaging assembly. The track comprises an inner surface for facing the track-engaging assembly, a ground-engaging outer surface for engaging the ground, and a plurality of traction projections projecting from the ground-engaging outer surface. The track also comprises a plurality of stiffening rods extending transversally to a longitudinal direction of the track. Each stiffening rod of the plurality of stiffening rods has a cross-section perpendicular to a longitudinal axis of the stiffening rod. The cross-section of the stiffening rod has an aspect ratio of at least 4.

[0012] In accordance with another aspect of the invention, there is provided a track for traction of an off-road vehicle. The track is mountable around a track-engaging assembly of the off-road vehicle. The track-engaging assembly comprises a drive wheel for driving the track. The track is elastomeric to be flexible around the track-engaging assembly. The track comprises an inner surface for facing the track-engaging assembly, a ground-engaging outer surface for engaging the ground, and a plurality of traction projections projecting from the ground-engaging outer surface. The track also comprises a plurality of stiffening rods extending transversally to a longitudinal direction of the track. Each stiffening rod of the plurality of stiffening rods has a cross-section perpendicular to a longitudinal axis of the stiffening rod. A ratio of (i) a thickness of the cross-section of the stiffening rod in a thickness direction of the track over (ii) a thickness of a carcass of the track from the inner surface to the ground-engaging outer surface in the thickness direction of the track is less than 0.7.

[0013] In accordance with another aspect of the invention, there is provided a track for traction of an off-road vehicle. The track is mountable around a track-engaging assembly of the off-road vehicle. The track-engaging assembly comprises a drive wheel for driving the track. The track is

elastomeric to be flexible around the track-engaging assembly. The track comprises an inner surface for facing the track-engaging assembly, a ground-engaging outer surface for engaging the ground, and a plurality of traction projections projecting from the ground-engaging outer surface. The track also comprises a plurality of stiffening rods extending transversally to a longitudinal direction of the track. Each stiffening rod of the plurality of stiffening rods has a cross-section perpendicular to a longitudinal axis of the stiffening rod. A thickness of the cross-section of the stiffening rod in a thickness direction of the track is less than 3.5 mm.

[0014] In accordance with another aspect of the invention, there is provided a track for traction of an off-road vehicle. The track is mountable around a track-engaging assembly of the off-road vehicle. The track-engaging assembly comprises a drive wheel for driving the track. The track is elastomeric to be flexible around the track-engaging assembly. The track comprises an inner surface for facing the track-engaging assembly, a ground-engaging outer surface for engaging the ground, and a plurality of traction projections projecting from the ground-engaging outer surface. The track is free of reinforcing fabric between the inner surface and the ground-engaging outer surface along at least part of a length of the track.

[0015] In accordance with another aspect of the invention, there is provided a track for traction of an off-road vehicle. The track is mountable around a track-engaging assembly of the off-road vehicle. The track-engaging assembly comprises a drive wheel for driving the track. The track is elastomeric to be flexible around the track-engaging assembly. The track comprises an inner surface for facing the track-engaging assembly, a ground-engaging outer surface for engaging the ground, and a plurality of traction projections projecting from the ground-engaging outer surface. The track is free of reinforcing fabric.

[0016] In accordance with another aspect of the invention, there is provided a track for traction of an off-road vehicle. The track is mountable around a track-engaging assembly of the off-road vehicle. The track-engaging assembly comprises a drive wheel for driving the track. The track is elastomeric to be flexible around the track-engaging assembly. The track comprises an inner surface for facing the track-engaging assembly, a ground-engaging outer surface for engaging the ground, and a plurality of traction projections projecting from the ground-engaging outer surface. A thickness of the track from the inner surface to the ground-engaging outer surface is no more than 0.25 inches. The track is free of reinforcing fabric between the inner surface and the ground-engaging outer surface along at least part of a length of the track.

[0017] In accordance with another aspect of the invention, there is provided a track for traction of an off-road vehicle. The track is mountable around a track-engaging assembly of the off-road vehicle. The track-engaging assembly comprises a drive wheel for driving the track. The track is elastomeric to be flexible around the track-engaging assembly. The track comprises an inner surface for facing the track-engaging assembly, a ground-engaging outer surface for engaging the ground, and a plurality of traction projections projecting from the ground-engaging outer surface. The track also comprises a plurality of stiffening rods

extending transversally to a longitudinal direction of the track. Each stiffening rod of the plurality of stiffening rods comprises a cavity.

[0018] In accordance with another aspect of the invention, there is provided a track for traction of an off-road vehicle. The track is mountable around a track-engaging assembly of the off-road vehicle. The track-engaging assembly comprises a drive wheel for driving the track and an idler wheel for contacting the track. The track is elastomeric to be flexible around the track-engaging assembly. The track comprises an inner surface for facing the track-engaging assembly, a ground-engaging outer surface for engaging the ground, and a plurality of traction projections projecting from the ground-engaging outer surface. The inner surface comprises an idler wheel path for the idler wheel. The track also comprises a plurality of stiffening rods extending transversally to a longitudinal direction of the track. Each stiffening rod of the plurality of stiffening rods comprises a recess aligned with the idler wheel path.

[0019] In accordance with another aspect of the invention, there is provided a track for traction of an off-road vehicle. The track is mountable around a track-engaging assembly of the off-road vehicle. The track-engaging assembly comprises a drive wheel for driving the track. The track is elastomeric to be flexible around the track-engaging assembly. The track comprises an inner surface for facing the track-engaging assembly, a ground-engaging outer surface for engaging the ground, and a plurality of traction projections projecting from the ground-engaging outer surface. The track also comprises a plurality of stiffening rods extending transversally to a longitudinal direction of the track. Each stiffening rod of the plurality of stiffening rods is shaped such that a thickness of elastomeric material between (i) the inner surface and (ii) a surface of the stiffening rod facing the inner surface varies in the longitudinal direction of the track.

[0020] In accordance with another aspect of the invention, there is provided a track for traction of an off-road vehicle. The track is mountable around a track-engaging assembly of the off-road vehicle. The track-engaging assembly comprises a drive wheel for driving the track. The track is elastomeric to be flexible around the track-engaging assembly. The track comprises an inner surface for facing the track-engaging assembly, a ground-engaging outer surface for engaging the ground, and a plurality of traction projections projecting from the ground-engaging outer surface. The track also comprises a plurality of stiffening rods extending transversally to a longitudinal direction of the track. Each stiffening rod of the plurality of stiffening rods is dimensioned such that the stiffening rod does not extend beneath laterally-outmost track-contacting devices of the track-engaging assembly.

[0021] In accordance with another aspect of the invention, there is provided a track for traction of an off-road vehicle. The track is mountable around a track-engaging assembly of the off-road vehicle. The track-engaging assembly comprises a drive wheel for driving the track. The track is elastomeric to be flexible around the track-engaging assembly. The track comprises an inner surface for facing the track-engaging assembly, a ground-engaging outer surface for engaging the ground, and a plurality of traction projections projecting from the ground-engaging outer surface. The track also comprises a plurality of stiffening rods extending transversally to a longitudinal direction of the

track. A first one of the stiffening rods and a second one of the stiffening rods being stacked in a thickness direction of the track.

[0022] In accordance with another aspect of the invention, there is provided a track for traction of an off-road vehicle. The track is mountable around a track-engaging assembly of the off-road vehicle. The track-engaging assembly comprises a drive wheel for driving the track. The track is elastomeric to be flexible around the track-engaging assembly. The track comprises an inner surface for facing the track-engaging assembly, a ground-engaging outer surface for engaging the ground, and a plurality of traction projections projecting from the ground-engaging outer surface. The track also comprises a plurality of stiffening rods extending transversally to a longitudinal direction of the track. A given one of the stiffening rods is located between adjacent ones of the traction projections in the longitudinal direction of the track.

[0023] In accordance with another aspect of the invention, there is provided a track for traction of an off-road vehicle. The track is mountable around a track-engaging assembly of the off-road vehicle. The track-engaging assembly comprises a drive wheel for driving the track. The track is elastomeric to be flexible around the track-engaging assembly. The track comprises an inner surface for facing the track-engaging assembly, a ground-engaging outer surface for engaging the ground, and a plurality of traction projections projecting from the ground-engaging outer surface. The track also comprises a plurality of stiffening rods extending transversally to a longitudinal direction of the track. A first one of the stiffening rods is different from a second one of the stiffening rods that succeeds the first one of the stiffening rods in the longitudinal direction of the track.

[0024] In accordance with another aspect of the invention, there is provided a track for traction of an off-road vehicle. The track is mountable around a track-engaging assembly of the off-road vehicle. The track-engaging assembly comprises a drive wheel for driving the track. The track is elastomeric to be flexible around the track-engaging assembly. The track comprises an inner surface for facing the track-engaging assembly, a ground-engaging outer surface for engaging the ground, and a plurality of traction projections projecting from the ground-engaging outer surface. The track also comprises a plurality of stiffening rods extending transversally to a longitudinal direction of the track. The plurality of stiffening rods includes an elastomeric fiber-reinforced rod.

[0025] In accordance with another aspect of the invention, there is provided a track for traction of an off-road vehicle. The track is mountable around a track-engaging assembly of the off-road vehicle. The track-engaging assembly comprises a drive wheel for driving the track. The track is elastomeric to be flexible around the track-engaging assembly. The track comprises an inner side for facing the track-engaging assembly and a ground-engaging outer side for engaging the ground. The ground-engaging outer side comprises a ground-engaging outer surface and a plurality of traction projections projecting from the ground-engaging outer surface. Elastomeric material of the ground-engaging outer side is different from elastomeric material between the inner side and the ground-engaging outer side such that at least one of: a hardness of the elastomeric material of the ground-engaging outer side is lower than a hardness of the

elastomeric material between the inner side and the ground-engaging outer side; and a modulus of elasticity of the elastomeric material of the ground-engaging outer side is lower than a modulus of elasticity of the elastomeric material between the inner side and the ground-engaging outer side.

[0026] In accordance with another aspect of the invention, there is provided a track for traction of an off-road vehicle. The track is mountable around a track-engaging assembly of the off-road vehicle. The track-engaging assembly comprises a drive wheel for driving the track and an idler wheel for contacting the track. The track is elastomeric to be flexible around the track-engaging assembly. The track comprises an inner surface for facing the track-engaging assembly, a ground-engaging outer surface for engaging the ground, and a plurality of traction projections projecting from the ground-engaging outer surface. The inner surface comprises an idler wheel path for the idler wheel. A shock absorbency of the track at a widthwise position of the idler wheel path is greater than a shock absorbency of the track at a widthwise position outside the idler wheel path.

[0027] In accordance with another aspect of the invention, there is provided a track for traction of an off-road vehicle. The track is mountable around a track-engaging assembly of the off-road vehicle. The track-engaging assembly comprises a drive wheel for driving the track and an idler wheel for contacting the track. The track is elastomeric to be flexible around the track-engaging assembly. The track comprises an inner surface for facing the track-engaging assembly, a ground-engaging outer surface for engaging the ground, and a plurality of traction projections projecting from the ground-engaging outer surface. Elastomeric material at a widthwise position of the idler wheel path is different from elastomeric material at a widthwise position outside the idler wheel path such that at least one of: a hardness of the elastomeric material at the widthwise position of the idler wheel path is lower than a hardness of the elastomeric material at the widthwise position outside the idler wheel path; and a modulus of elasticity of the elastomeric material at the widthwise position of the idler wheel path is lower than a modulus of elasticity of the elastomeric material at the widthwise position outside the idler wheel path.

[0028] In accordance with another aspect of the invention, there is provided a track for traction of an off-road vehicle. The track is mountable around a track-engaging assembly of the off-road vehicle. The track-engaging assembly comprises a drive wheel for driving the track. The track is elastomeric to be flexible around the track-engaging assembly. The track comprises an inner surface for facing the track-engaging assembly, a ground-engaging outer surface for engaging the ground, and a plurality of traction projections projecting from the ground-engaging outer surface. The track also comprises a layer of stiffening cables extending transversally to a longitudinal direction of the track.

[0029] In accordance with another aspect of the invention, there is provided a track for traction of an off-road vehicle. The track is mountable around a track-engaging assembly of the off-road vehicle. The track-engaging assembly comprises a drive wheel for driving the track. The track is elastomeric to be flexible around the track-engaging assembly. The track comprises an inner surface for facing the track-engaging assembly, a ground-engaging outer surface for engaging the ground, and a plurality of traction projec-

tions projecting from the ground-engaging outer surface. The track also comprises a plurality of stiffening rods extending transversally to a longitudinal direction of the track. The track further comprises a layer of stiffening cables extending transversally to the longitudinal direction of the track.

[0030] In accordance with another aspect of the invention, there is provided a track for traction of an off-road vehicle. The track is mountable around a track-engaging assembly of the off-road vehicle. The track-engaging assembly comprises a drive wheel for driving the track and an idler wheel for contacting the track. The track is elastomeric to be flexible around the track-engaging assembly. The track comprises an inner surface for facing the track-engaging assembly, a ground-engaging outer surface for engaging the ground, and a plurality of traction projections projecting from the ground-engaging outer surface. The ground-engaging outer surface defines an idler wheel path projection that is located between adjacent ones of the traction projections in a longitudinal direction of the track and that is aligned with the idler wheel path in a widthwise direction of the track.

[0031] In accordance with another aspect of the invention, there is provided a track for traction of an off-road vehicle. The track is mountable around a track-engaging assembly of the off-road vehicle. The track-engaging assembly comprises a drive wheel for driving the track. The track is elastomeric to be flexible around the track-engaging assembly. The track comprises an inner surface for facing the track-engaging assembly, a ground-engaging outer surface for engaging the ground, and a plurality of traction projections projecting from the ground-engaging outer surface. At least one of the inner surface and the ground-engaging outer surface comprises a plurality of longitudinal rigidifiers for imparting longitudinal rigidity to the track.

[0032] In accordance with another aspect of the invention, there is provided a track for traction of an off-road vehicle. The track is mountable around a track-engaging assembly of the off-road vehicle. The track-engaging assembly comprises a drive wheel for driving the track and an idler wheel for contacting the track. The track is elastomeric to be flexible around the track-engaging assembly. The track comprises an inner surface for facing the track-engaging assembly, a ground-engaging outer surface for engaging the ground, and a plurality of traction projections projecting from the ground-engaging outer surface. The inner surface comprises an idler wheel path for the idler wheel. The idler wheel path is uneven in a longitudinal direction of the track.

[0033] In accordance with another aspect of the invention, there is provided a track for traction of an off-road vehicle. The track is mountable around a track-engaging assembly of the off-road vehicle. The track-engaging assembly comprises a drive wheel for driving the track. The track is elastomeric to be flexible around the track-engaging assembly. The track comprises an inner surface for facing the track-engaging assembly, a ground-engaging outer surface for engaging the ground, and a plurality of traction projections projecting from the ground-engaging outer surface. The track is at least mainly made of fiber-reinforced elastomeric material.

[0034] In accordance with another aspect of the invention, there is provided a track for traction of an off-road vehicle. The track is mountable around a track-engaging assembly of the off-road vehicle. The track-engaging assembly com-

prises a drive wheel for driving the track and an idler wheel for contacting the track. The track is elastomeric to be flexible around the track-engaging assembly. The track comprises an inner surface for facing the track-engaging assembly, a ground-engaging outer surface for engaging the ground, and a plurality of traction projections projecting from the ground-engaging outer surface. Cellular elastomeric material is located at a widthwise position of the idler wheel path.

[0035] In accordance with another aspect of the invention, there is provided a track-engaging assembly for a track system providing traction of an off-road vehicle. The track-engaging assembly is configured to engage a track disposed around the track-engaging assembly. The track is elastomeric to be flexible around the track-engaging assembly. The track comprises: an inner surface for facing the track-engaging assembly, the inner surface comprising an idler wheel path; a ground-engaging outer surface for engaging the ground; and a plurality of traction projections projecting from the ground-engaging outer surface. The track-engaging assembly comprises a drive wheel for driving the track and a plurality of idler wheels for contacting the track. The plurality of idler wheels includes a set of idler wheels spaced apart in a longitudinal direction of the track system and disposed to roll on the idler wheel path of the track. The set of idler wheels is arranged such that a longitudinal spacing of any two successive idler wheels of the set of idler wheels is less than half of a length of the track system.

[0036] In accordance with another aspect of the invention, there is provided a track-engaging assembly for a track system providing traction of an off-road vehicle. The track-engaging assembly is configured to engage a track disposed around the track-engaging assembly. The track is elastomeric to be flexible around the track-engaging assembly. The track comprises: an inner surface for facing the track-engaging assembly, the inner surface comprising an idler wheel path; a ground-engaging outer surface for engaging the ground; and a plurality of traction projections projecting from the ground-engaging outer surface. The track-engaging assembly comprises a drive wheel for driving the track and a plurality of idler wheels for contacting the track. The plurality of idler wheels includes at least four idler wheels spaced apart in a longitudinal direction of the track and disposed to roll on the idler wheel path of the track.

[0037] In accordance with another aspect of the invention, there is provided a track-engaging assembly for a track system providing traction of an off-road vehicle. The track-engaging assembly is configured to engage a track disposed around the track-engaging assembly. The track is elastomeric to be flexible around the track-engaging assembly. The track comprises an inner surface for facing the track-engaging assembly, a ground-engaging outer surface for engaging the ground, and a plurality of traction projections projecting from the ground-engaging outer surface. The track-engaging assembly comprises a drive wheel for driving the track and a plurality of side rails spaced apart in a widthwise direction of the track system to slide against a bottom run of the track. The plurality of side rails is arranged such that a widthwise spacing of any two adjacent side rails of the plurality of side rails is less than half of a width of the track system.

[0038] In accordance with another aspect of the invention, there is provided a track-engaging assembly for a track system providing traction of an off-road vehicle. The track-

engaging assembly is configured to engage a track disposed around the track-engaging assembly. The track is elastic to be flexible around the track-engaging assembly. The track comprises an inner surface for facing the track-engaging assembly, a ground-engaging outer surface for engaging the ground, and a plurality of traction projections projecting from the ground-engaging outer surface. The track-engaging assembly comprises a drive wheel for driving the track and a plurality of side rails spaced apart in a widthwise direction of the track system to slide against a bottom run of the track. The plurality of side rails includes at least three slide rails.

[0039] In accordance with another aspect of the invention, there is provided a track-engaging assembly for a track system providing traction of an off-road vehicle. The track-engaging assembly is configured to engage a track disposed around the track-engaging assembly. The track is elastic to be flexible around the track-engaging assembly. The track comprises an inner surface for facing the track-engaging assembly, a ground-engaging outer surface for engaging the ground, and a plurality of traction projections projecting from the ground-engaging outer surface. The track-engaging assembly comprises a drive wheel for driving the track and an idler wheel for contacting a bottom run of the track. The track-engaging assembly also comprises a track tensioner for maintaining a tension of the track.

[0040] In accordance with another aspect of the invention, there is provided a track-engaging assembly for a track system providing traction of an off-road vehicle. The track-engaging assembly is configured to engage a track disposed around the track-engaging assembly. The track is elastic to be flexible around the track-engaging assembly. The track comprises an inner surface for facing the track-engaging assembly, a ground-engaging outer surface for engaging the ground, and a plurality of traction projections projecting from the ground-engaging outer surface. The track-engaging assembly comprises a drive wheel for driving the track and an idler wheel for contacting a bottom run of the track. The track-engaging assembly also comprises a track tensioner for maintaining a tension of the track. The track tensioner comprises a resilient device for contacting a segment of a top run of the track.

[0041] These and other aspects of the invention will now become apparent to those of ordinary skill in the art upon review of the following description of embodiments of the invention in conjunction with the accompanying drawings.

BRIEF DESCRIPTION OF THE DRAWINGS

[0042] A detailed description of embodiments of the invention is provided below, by way of example only, with reference to the accompanying drawings, in which:

[0043] FIG. 1 shows an example of a snowmobile comprising a track system in accordance with an embodiment of the invention;

[0044] FIG. 2 shows a perspective view of components of the track system;

[0045] FIG. 3 shows a perspective view of part of a track of the track system;

[0046] FIGS. 4 to 7A respectively show an elevation view, a plan view of an inner side, a longitudinal cross-sectional view, and a widthwise cross-sectional view of part of the track;

[0047] FIGS. 7B to 7D shows a widthwise cross-sectional view of part of the track according to other embodiments of the invention;

[0048] FIGS. 8 and 9 respectively show the track with and without a slide member;

[0049] FIGS. 10 to 21 show different shapes of transversal stiffening rods of the track in accordance with various embodiments of the invention;

[0050] FIGS. 22A to 25 show different arrangements of transversal stiffening rods of the track in accordance with various embodiments of the invention;

[0051] FIG. 26 shows a reinforced elastomeric transversal stiffening rod in accordance with an embodiment of the invention;

[0052] FIGS. 27 to 31 show zones of the track with different properties in accordance with various embodiments of the invention;

[0053] FIGS. 32A to 32D show various embodiments of the track comprising a layer of transversal stiffening cables in accordance with various embodiments of the invention;

[0054] FIGS. 33A and 33B show idler wheel path projections on a ground-engaging outer side of the track in accordance with an embodiment of the invention;

[0055] FIGS. 34A and 34B show idler wheel path projections on a ground-engaging outer side of the track in accordance with another embodiment of the invention;

[0056] FIG. 35 shows longitudinally uneven idler wheel paths on an inner side of the track in accordance with an embodiment of the invention;

[0057] FIGS. 36 and 37 show different lengths of transversal stiffening rods of the track in accordance with various embodiments of the invention;

[0058] FIGS. 38 and 39 show longitudinal rigidifiers on an inner surface of a carcass of the track in accordance with an embodiment of the invention;

[0059] FIGS. 40 and 41 show different configurations of a suspension unit of the track system in accordance with various embodiments of the invention;

[0060] FIGS. 42 and 43 show different examples of implementation of a track tensioner of the track system in accordance with various embodiments of the invention;

[0061] FIG. 44 shows an example of implementation in which the track is at least mainly made of fiber-reinforced elastomeric material in accordance with an embodiment of the invention;

[0062] FIGS. 45A and 45B show an example of an all-terrain vehicle (ATV) comprising track systems in accordance with an embodiment of the invention; and

[0063] FIGS. 46A and 46B show the ATV equipped with ground-engaging wheels instead of the track systems.

[0064] It is to be expressly understood that the description and drawings are only for the purpose of illustrating certain embodiments of the invention and are an aid for understanding. They are not intended to be a definition of the limits of the invention.

DETAILED DESCRIPTION OF EMBODIMENTS

[0065] FIG. 1 shows an example of a snowmobile 10 in accordance with an embodiment of the invention. The snowmobile 10 is designed for travelling on snow and in some cases ice. In this embodiment, the snowmobile 10 comprises a frame 11, a powertrain 12, a track system 14, a ski assembly 17, a seat 18, and a user interface 20, which enables a user to control the snowmobile 10.

[0066] The powertrain 12 is configured for generating motive power and transmitting motive power to the track system 14 to propel the snowmobile 10 on the ground. To that end, the powertrain 12 comprises a prime mover 15, which is a source of motive power that comprises one or more motors (e.g., an internal combustion engine, an electric motor, etc.). For example, in this embodiment, the prime mover 15 comprises an internal combustion engine. In other embodiments, the prime mover 15 may comprise another type of motor (e.g., an electric motor) or a combination of different types of motor (e.g., an internal combustion engine and an electric motor). The prime mover 15 is in a driving relationship with the track system 14. That is, the powertrain 12 transmits motive power from the prime mover 15 to the track system 14 in order to drive (i.e., impart motion to) the track system 14.

[0067] The ski assembly 17 is turnable to allow steering of the snowmobile 10. In this embodiment, the ski assembly 17 comprises a pair of skis 19 connected to the frame 11 via a front suspension unit.

[0068] The seat 18 accommodates the user of the snowmobile 10. In this case, the seat 18 is a straddle seat and the snowmobile 10 is usable by a single person such that the seat 18 accommodates only that person driving the snowmobile 10. In other cases, the seat 18 may be another type of seat, and/or the snowmobile 10 may be usable by two individuals, namely one person driving the snowmobile 10 and a passenger, such that the seat 18 may accommodate both of these individuals (e.g., behind one another) or the snowmobile 10 may comprise an additional seat for the passenger.

[0069] The user interface 20 allows the user to interact with the snowmobile 10 to control the snowmobile 10. More particularly, the user interface 20 comprises an accelerator, a brake control, and a steering device that are operated by the user to control motion of the snowmobile 10 on the ground. In this case, the steering device comprises handlebars, although it may comprise a steering wheel or other type of steering element in other cases. The user interface 20 also comprises an instrument panel (e.g., a dashboard) which provides indicators (e.g., a speedometer indicator, a tachometer indicator, etc.) to convey information to the user.

[0070] The track system 14 engages the ground to generate traction of the snowmobile 10. In this embodiment, the track system 14 comprises a track-engaging assembly 24 and a track 21 disposed around the track-engaging assembly 24. More particularly, in this embodiment, with additional reference to FIG. 2, the track-engaging assembly 24 comprises a plurality of wheels, including a plurality of drive wheels 22 and a plurality of idler wheels, which includes rear idler wheels 26₁-26₄, lower roller wheels 28₁-28₆, and upper roller wheels 30₁, 30₂. The track-engaging assembly 24 also comprises a plurality of slide rails 33₁, 33₂. Various components of the track-engaging assembly 24, including the idler wheels 26₁-26₄, 28₁-28₆, 30₁, 30₂ and the slide rails 33₁, 33₂ are supported by a suspension unit 16. The track system 14 has a longitudinal direction and a first longitudinal end and a second longitudinal end that define a length of the track system 14. The track system 14 has a widthwise direction and a width that is defined by a width of the track 21. The track system 14 has a height direction that is normal to its longitudinal direction and its widthwise direction.

[0071] The track 21 engages the ground to provide traction to the snowmobile 10. A length of the track 21 allows the track 21 to be mounted around the track-engaging assembly

24. In view of its closed configuration without ends that allows it to be disposed and moved around the track-engaging assembly 24, the track 21 can be referred to as an “endless” track. With additional reference to FIGS. 3 to 7A, the endless track 21 comprises an inner side 25 and a ground-engaging outer side 27. The inner side 25 faces the wheels 22, 26₁-26₄, 28₁-28₆, 30₁, 30₂ and the slide rails 33₁, 33₂. The ground-engaging outer side 27 engages the ground. A top run 65 of the endless track 21 extends between the longitudinal ends of the track system 14 and over the wheels 22, 26₁-26₄, 28₁-28₆, 30₁, 30₂, and a bottom run of the endless track 21 extends between the longitudinal ends of the track system 14 and under the wheels 22, 26₁-26₄, 28₁-28₆, 30₁, 30₂ and the slide rails 33₁, 33₂. The endless track 21 has a longitudinal axis which defines a longitudinal direction of the track 21 (i.e., a direction generally parallel to its longitudinal axis) and transversal directions of the track (i.e., directions transverse to its longitudinal axis), including a widthwise direction of the track (i.e., a lateral direction generally perpendicular to its longitudinal axis). The endless track 21 has a thickness direction normal to its longitudinal and widthwise directions.

[0072] The track 21 is elastomeric, i.e., comprises elastomeric material, to be flexible around the track-engaging assembly 24. The elastomeric material of the track 21 can include any polymeric material with suitable elasticity. In this embodiment, the elastomeric material of the track 21 includes rubber. Various rubber compounds may be used and, in some cases, different rubber compounds may be present in different areas of the track 21. In other embodiments, the elastomeric material of the track 21 may include another elastomer in addition to or instead of rubber (e.g., polyurethane elastomer).

[0073] More particularly, the track 21 comprises an endless body 35 underlying its inner side 25 and ground-engaging outer side 27. In view of its underlying nature, the body 36 will be referred to as a “carcass”. The carcass 35 is elastomeric in that it comprises elastomeric material 38 which allows the carcass 35 to elastically change in shape and thus the endless track 21 to flex as it is in motion around the track-engaging assembly 24. The elastomeric material 38 can be any polymeric material with suitable elasticity. In this embodiment, the elastomeric material 38 includes rubber. Various rubber compounds may be used and, in some cases, different rubber compounds may be present in different areas of the carcass 35. In other embodiments, the elastomeric material 38 may include another elastomer in addition to or instead of rubber (e.g., polyurethane elastomer).

[0074] In this embodiment, the carcass 35 comprises a plurality of reinforcements embedded in its elastomeric material 38. These reinforcements can take on various forms.

[0075] For example, in this embodiment, the carcass 35 comprises a plurality of transversal stiffening rods 36₁-36_N that extend transversally to the longitudinal direction of the endless track 21 to provide transversal rigidity to the track 21. More particularly, in this embodiment, the transversal stiffening rods 36₁-36_N extend in the widthwise direction of the track 21. Each of the transversal stiffening rods 36₁-36_N may have various shapes and be made of any suitably rigid material (e.g., metal, polymer or composite material).

[0076] As another example, in this embodiment, the carcass 35 comprises a plurality of reinforcing cables 37₁-37_M

(which indicates any number of reinforcing cables $37_1, 37_2, \dots, 37_M$) that are adjacent to one another and extend generally in the longitudinal direction of the endless track **21** to enhance strength in tension of the track **21** along its longitudinal direction. In this case, each of the reinforcing cables 37_1-37_M is a cord including a plurality of strands (e.g., textile fibers or metallic wires). In other cases, each of the reinforcing cables 37_1-37_M may be another type of cable and may be made of any material suitably flexible longitudinally (e.g., fibers or wires of metal, plastic or composite material).

[0077] As yet another example, in this embodiment, the carcass **35** comprises a layer of reinforcing fabric **43**. The reinforcing fabric **43** comprises thin pliable material made usually by weaving, felting, knitting, interlacing, or otherwise crossing natural or synthetic elongated fabric elements, such as fibers, filaments, strands and/or others, such that some elongated fabric elements extend transversally to the longitudinal direction of the track **21** to have a reinforcing effect in a transversal direction of the track **21**. For instance, the reinforcing fabric **43** may comprise a ply of reinforcing woven fibers (e.g., nylon fibers or other synthetic fibers). For example, the reinforcing fabric **43** may protect the transversal stiffening rods 36_1-36_N , improve cohesion of the track **21**, and counter its elongation.

[0078] The carcass **35** may be molded into shape in a molding process during which the rubber **38** is cured. For example, in this embodiment, a mold may be used to consolidate layers of rubber providing the rubber **38** of the carcass **35**, the reinforcing cables 37_1-37_M and the layer of reinforcing fabric **43**.

[0079] In this embodiment, the endless track **21** is a one-piece “jointless” track such that the carcass **35** is a one-piece jointless carcass. In other embodiments, the endless track **21** may be a “jointed” track (i.e., having at least one joint connecting adjacent parts of the track **21**) such that the carcass **35** is a jointed carcass (i.e., which has adjacent parts connected by the at least one joint). For example, in some embodiments, the endless track **21** may comprise a plurality of track sections interconnected to one another at a plurality of joints, in which case each of these track sections includes a respective part of the carcass **35**. In other embodiments, the endless track **21** may be a one-piece track that can be closed like a belt with connectors at both of its longitudinal ends to form a joint.

[0080] The ground-engaging outer side **27** of the track **21** comprises a ground-engaging outer surface **31** of the carcass **35** and a plurality of traction projections 58_1-58_T that project outwardly from the ground-engaging outer surface **31** to enhance traction on the ground. The traction projections 58_1-58_T , which can be referred to as “traction lugs” or “traction profiles”, may have any suitable shape (e.g., curved shapes, shapes with straight parts and curved parts, etc.).

[0081] In this embodiment, each of the traction projection 58_1-58_T is an elastomeric traction projection in that it comprises elastomeric material **41**. The elastomeric material **41** can be any polymeric material with suitable elasticity. More particularly, in this embodiment, the elastomeric material **41** includes rubber. Various rubber compounds may be used and, in some cases, different rubber compounds may be present in different areas of each of the traction projections 58_1-58_T . In other embodiments, the elastomeric material **41** may include another elastomer in addition to or instead of rubber (e.g., polyurethane elastomer).

[0082] The traction projections 58_1-58_T may be provided on the ground-engaging outer side **27** in various ways. For example, in this embodiment, the traction projections 58_1-58_T are provided on the ground-engaging outer side **27** by being molded with the carcass **35**.

[0083] The inner side **25** of the track **21** comprises an inner surface **32** of the carcass **35** and a plurality of inner projections 34_1-34_D (which indicates any number of inner projections $34_1 \dots 34_8 \dots 34_{15} \dots 34_{30} \dots 34_D$) that project inwardly from the inner surface **32** and are positioned to contact at least some of the wheels **22**, 26_1-26_4 , 28_1-28_6 , 30_1 , 30_2 and/or some of the slide rails 33_1 , 33_2 to do at least one of driving (i.e., imparting motion to) the track **21** and guiding the track **21**. Since each of them is used to do at least one of driving the track **21** and guiding the track **21**, the inner projections 34_1-34_D can be referred to as “drive/guide projections” or “drive/guide lugs”. In some cases, a drive/guide lug 34_i may interact with a given one of the drive wheels **22** to drive the track **21**, in which case the drive/guide lug 34_i is a drive lug. In other cases, a drive/guide lug 34_i may interact with a given one of the idler wheels 26_1-26_4 , 28_1-28_6 , 30_1 , 30_2 and/or a given one of the slide rails 33_1 , 33_2 to guide the track **21** to maintain proper track alignment and prevent de-tracking without being used to drive the track **21**, in which case the drive/guide lug 34_i is a guide lug. In yet other cases, a drive/guide lug 34_i may both (i) interact with a given one of the drive wheels **22** to drive the track **21** and (ii) interact with a given one of the idler wheels 26_1-26_4 , 28_1-28_6 , 30_1 , 30_2 and/or a given one of the slide rails 33_1 , 33_2 to guide the track **21**, in which case the drive/guide lug 34_i is both a drive lug and a guide lug.

[0084] In this embodiment, each of the drive/guide lugs 34_1-34_D is an elastomeric drive/guide lug in that it comprises elastomeric material **42**. The elastomeric material **42** can be any polymeric material with suitable elasticity. More particularly, in this embodiment, the elastomeric material **42** includes rubber. Various rubber compounds may be used and, in some cases, different rubber compounds may be present in different areas of each of the drive/guide lugs 34_1-34_D . In other embodiments, the elastomeric material **42** may include another elastomer in addition to or instead of rubber (e.g., polyurethane elastomer).

[0085] The drive/guide lugs 34_1-34_D may be provided on the inner side **25** in various ways. For example, in this embodiment, the drive/guide lugs 34_1-34_D are provided on the inner side **25** by being molded with the carcass **35**.

[0086] The carcass **35** has a thickness T_c which is relatively small. The thickness T_c of the carcass **35** is measured from the inner surface **32** to the ground-engaging outer surface **31** of the carcass **35** between longitudinally-adjacent ones of the traction projections 58_1-58_T . For example, in some embodiments, the thickness T_c of the carcass **35** may be no more than 0.25 inches, in some cases no more than 0.24 inches, in some cases no more than 0.23 inches, in some cases no more than 0.22 inches, in some cases no more than 0.21 inches, in some cases no more than 0.20 inches, and in some cases even less (e.g., 0.18 or 0.17 inches). The thickness T_c of the carcass **35** may have any other suitable value in other embodiments.

[0087] The endless track **21** may be constructed and/or manufactured in various other ways in other embodiments.

[0088] For example, FIG. 7B shows an embodiment in which the track **21** is free of reinforcing fabric between the inner surface **32** and the ground-engaging outer surface **31**

of the carcass 35 along at least part of the length of the track 21. That is, there is no layer of reinforcing fabric in the carcass 35 along at least part of the length of the track 21. In this embodiment, the track 21 is free of reinforcing fabric between the inner surface 32 and the ground-engaging outer surface 31 along at least a majority of the length of the track 21. More particularly, in this example of implementation, the track 21 is free of reinforcing fabric between the inner surface 32 and the ground-engaging outer surface 31 along an entirety of the length of the track 21. There is thus no layer of reinforcing fabric in the carcass 35 of the track 21 in this example of implementation. Specifically, in this case, the track 21 is free of reinforcing fabric, i.e., there is no layer of reinforcing fabric in the track 21.

[0089] This lack of reinforcing fabric layer may reduce a weight of the track 21. The lack of reinforcing fabric layer may also reduce a power consumption to drive the track 21. That is, when operated at a given speed, the track 21 may consume less power than if it had a reinforcing fabric layer (e.g., the layer of reinforcing fabric 43) embedded in the carcass 35 and extending along at least a majority (e.g., an entirety) of the length of the track 21 but was otherwise identical. For instance, in some examples of implementation, the track 21 may consume less power when operated at a speed above 40 miles per hour, in some cases above 60 miles per hour, and in some cases above 80 miles per hour.

[0090] More particularly, in this embodiment, the carcass 35 comprises the reinforcing cables 37₁-37_M and the transversal stiffening rods 36₁-36_N embedded in its rubber 38 but is free of any reinforcing fabric layer (i.e., the layer of reinforcing fabric 43 discussed above is omitted). In this case, the reinforcing cables 37₁-37_M are located between the transversal stiffening rods 36₁-36_N and the inner surface 32 of the carcass 35 in the thickness direction of the track 21. In other cases, as shown in FIG. 7C, the reinforcing cables 37₁-37_M may be located between the transversal stiffening rods 36₁-36_N and the outer surface 31 of the carcass 35 in the thickness direction of the track 21. In such cases, the reinforcing cables 37₁-37_M may act to protect the transversal stiffening rods 36₁-36_N.

[0091] The track 21 free of any reinforcing fabric layer may be configured in various other ways in other embodiments. For example, in some embodiments, the track 21 may also be free of transversal stiffening rods, as shown in FIG. 7D.

[0092] In other embodiments, the track 21 may be free of reinforcing fabric between the inner surface 32 and the ground-engaging outer surface 31 of the carcass 35 along part of the length of the track 21 but still include some reinforcing fabric (e.g., between the inner surface 32 and the ground-engaging surface 31 along one or more segments of the length of the track 21, or within one or more of the drive/guide lugs 34₁-34_D and/or one or more of the traction projections 58₁-58_T).

[0093] Elastomeric material of a given portion of the endless track 21, including the elastomeric material 38 of the carcass 35, the elastomeric material 41 of one of the traction projection 58₁-58_T, and the elastomeric material 42 of one of the drive/guide lugs 34₁-34_D, has various material properties, including a hardness (e.g., durometers in a Shore A hardness scale) and a modulus of elasticity, which can have any suitable value.

[0094] If the elastomeric material of the given portion of the track 21 is constituted of a single elastomer, the hardness

of the elastomeric material of the given portion of the track 21 is the hardness of this single elastomer. Alternatively, if the elastomeric material of the given portion of the track 21 is constituted of two or more different elastomers, the hardness of the elastomeric material of the given portion of the track 21 is taken as an average hardness, which is obtained by multiplying a proportion of each elastomer in the elastomeric material of the given portion of the track 21 by that elastomer's hardness and then summing the results.

[0095] That is, if the elastomeric material of the given portion of the track 21 is constituted of N elastomers, the average hardness is $A_{avg} = \sum_{i=1}^N P_i A_i$, where A_i is the hardness of elastomer "i" and P_i is the proportion (%) of elastomer "i" in the elastomeric material of the given portion of the track 21. In situations where this calculated value is not an integer and the hardness scale is only in integers, this calculated value rounded to the nearest integer gives the average hardness. An elastomer's hardness can be obtained from a standard ASTM D-2240 test (or equivalent test).

[0096] Similarly, if the elastomeric material of the given portion of the track 21 is constituted of a single elastomer, the modulus of elasticity of the elastomeric material of the given portion of the track 21 is the modulus of elasticity of this single elastomer. Alternatively, if the elastomeric material of the given portion of the track 21 is constituted of two or more different elastomers, the modulus of elasticity of the elastomeric material of the given portion of the track 21 is taken as an average modulus of elasticity, which is obtained by multiplying a proportion (%) of each elastomer in the elastomeric material of the given portion of the track 21 by that elastomer's modulus of elasticity and then summing the results. That is, if the elastomeric material of the given portion of the track 21 is constituted of N elastomers, the average modulus of elasticity is $\lambda_{avg} = \sum_{i=1}^N P_i \lambda_i$, where λ_i is the modulus of elasticity of elastomer "i" and P_i is the proportion (%) of elastomer "i" in the elastomeric material of the given portion of the track 21. For instance, in an embodiment in which the elastomeric material of the given portion of the track 21 is constituted of two types of rubbers, say rubber "A" having a modulus of elasticity of 1.9 MPa and being present in a proportion of 15% and rubber "B" having a modulus of elasticity of 6.3 MPa and being present in a proportion of 85%, the average modulus of elasticity of the elastomeric material of the given portion of the track 21 is 5.64 MPa. An elastomer's modulus of elasticity can be obtained from a standard ASTM D-412-A test (or equivalent test) based on a measurement at 100% elongation of the elastomer.

[0097] Each of the drive wheels 22 is rotatable on an axle of the snowmobile 10 for driving the endless track 21. That is, power generated by the prime mover 15 and delivered over the powertrain 12 of the snowmobile 10 rotates the axle, which rotates the drive wheels 22, which impart motion of the track 21. In this embodiment, each drive wheel 22 comprises a drive sprocket engaging some of the drive/guide lugs 34₁-34_D of the inner side 25 of the track 21 in order to drive the track 21. In other embodiments, the drive wheel 22 may be configured in various other ways. For example, in embodiments where the track 21 comprises drive holes, the drive wheel 22 may have teeth that enter these holes in order to drive the track 21. As yet another example, in some embodiments, the drive wheel 22 may frictionally engage the inner side 25 of the track 21 in order to frictionally drive the track 21. The drive wheels 22 may

be arranged in other configurations and/or the track system **14** may comprise more or less drive wheels (e.g., a single drive wheel, more than two drive wheels, etc.) in other embodiments.

[0098] The idler wheels **26₁-26₄**, **28₁-28₆**, **30₁**, **30₂** are not driven by power supplied by the prime mover **15**, but are rather used to do at least one of guiding the track **21** as it is driven by the drive wheels **22** tensioning the track **21**, and supporting part of the weight of the snowmobile **10** on the ground via the track **21**. More particularly, in this embodiment, the rear idler wheels **26₁-26₄** are trailing idler wheels that maintain the track **21** in tension, guide the track **21** as it wraps around them, and can help to support part of the weight of the snowmobile **10** on the ground via the track **21**. The lower roller wheels **28₁-28₆** roll on the inner side **25** of the track **21** along the bottom run of the track **21** to apply the bottom run on the ground. The upper roller wheels **30₁**, **30₂** roll on the inner side **25** of the track **21** along the top run **65** of the track **21** to support and guide the top run **65** as the track **21** moves. The idler wheels **26₁-26₄**, **28₁-28₆**, **30₁**, **30₂** may be arranged in other configurations and/or the track assembly **14** may comprise more or less idler wheels in other embodiments.

[0099] The idler wheels **26₁-26₄**, **28₁-28₆**, **30₁**, **30₂** move on respective ones of a plurality of idler wheel paths **501-504** of the inner surface **32** of the carcass **35** of the endless track **21**. Each of the idler wheel paths **501-504** extends adjacent to respective ones of the drive/guide lugs **34₁-34_D** to allow these lugs to guide motion of the track **21** around the track-engaging assembly **24**. As the roller wheels **28₁-28₆**, **30₁**, **30₂** roll on respective ones of the idler wheel paths **501-504**, these paths can be referred to as “rolling paths”.

[0100] The slide rails **33₁**, **33₂** slide on the inner side **25** of the endless track **21** along the bottom run of the track **21** to apply the bottom run onto the ground. In this embodiment, the slide rails **33₁**, **33₂** are curved upwardly in a front region of the track system **14** to guide the track **21** towards the drive wheels **22**. In some cases, as shown in FIG. **8**, the endless track **21** may comprise slide members that slide against the slide rails **33₁**, **33₂** to reduce friction. The slide members, which can sometimes be referred to as “clips”, may be mounted via holes **40₁-40_H** arranged in two rows extending longitudinally and spaced apart laterally of the track **21**. In other cases, as shown in FIG. **9**, the endless track **21** may be free of such slide members. The slide rails **33₁**, **33₂** may be arranged in other configurations and/or the track assembly **14** may comprise more or less slide rails in other embodiments.

[0101] Various considerations may be important when it comes to use and performance of the snowmobile **10**.

[0102] For example, in use, the snowmobile **10** generates noise, including noise generated by the track system **14**. Various factors may contribute to the noise generated by the track system **14**. For example, in some cases: impacts between the idler wheels **26₁-26₄**, **28₁-28₆**, **30₁**, **30₂** and the transversal stiffening rods **36₁-36_N** of the endless track **21**; impacts between the slide rails **33₁**, **33₂** and the transversal stiffening rods **36₁-36_N** of the track **21**; impacts between the slide rails **33₁**, **33₂** and the clips of the track **21**, if any; impacts between the traction projections **58₁-58_T** of the track **21** and the ground; and contact between the track **21** and the drive wheels **22** may be contributors to the noise generated by the track system **14**.

[0103] As another example, traction and floatation provided by the track system **14** depend on rigidity of the endless track **21**. While longitudinal flexibility of the track **21** is desirable in order to efficiently drive the track around the track-engaging assembly **24**, transversal rigidity of the track **21** is desirable in order to have a proper ground-contacting area for traction and floatation.

[0104] The snowmobile **10**, including the track system **14**, may therefore be configured to have a reduced noise profile so as to generate less noise, enhanced track rigidity characteristics to improve its traction and floatation, and/or other features improving use and performance of the snowmobile **10**. This may be achieved in various ways in various embodiments, examples of which will now be discussed.

1. Shape of Transversal Stiffening Rod

[0105] In some embodiments, the transversal stiffening rods **36₁-36_N** of the endless track **21** may be shaped in order to reduce noise generation and/or for other purposes (e.g., weight reduction, controlled transversal rigidity, etc.). Various shapes of the transversal stiffening rods **36₁-36_N** can be implemented in various embodiments, examples of which are discussed below.

1.1 Transversal Stiffening Rods Shaped to Increase Thickness of Elastomeric Material

[0106] In some embodiments, the transversal stiffening rods **36₁-36_N** may be shaped so as to increase a thickness of elastomeric material of the endless track **21** at locations of the rods **36₁-36_N**. That is, the transversal stiffening rods **36₁-36_N** may be shaped such that a thickness of elastomeric material where they are located is greater than that which would exist if they were replaced with conventional transversal stiffening rods having a generally semicircular or half-moon-shaped cross-section, such as those shown in FIG. **6**, but the track **21** was otherwise identical and had the same transversal rigidity. The greater thickness of elastomeric material can provide enhanced shock absorption, and therefore reduce noise generation, when the idler wheels **26₁-26₄**, **28₁-28₆**, **30₁**, **30₂** and the slide rails **33₁**, **33₂** cross the transversal stiffening rods **36₁-36_N**. Also, in some cases, the transversal stiffening rods **36₁-36_N** may have a smaller cross-section than conventional rods and this may make them less rigid and thus less noisy when crossed by the idler wheels **26₁-26₄**, **28₁-28₆**, **30₁**, **30₂** and the slide rails **33₁**, **33₂**.

[0107] Various shapes of the transversal stiffening rods **36₁-36_N** can be implemented to increase the thickness of elastomeric material in various embodiments, examples of which are discussed below.

1.1.1 Rod Cross-Section being Elongate (i.e., Having a High Aspect Ratio)

[0108] In some embodiments, as shown in FIGS. **10** and **11**, a transversal stiffening rod **36_x** may have a cross-section which is elongate, i.e., has a high aspect ratio C_L/C_S . The cross-section of the transversal stiffening rod **36_x** is taken perpendicularly to a longitudinal axis **86** of the rod **36_x** and is elongate since a longest dimension C_L of the cross-section is significantly greater than a smallest dimension C_S of the cross-section. In this example, the longest dimension C_L of the cross-section of the transversal stiffening rod **36_x** is in the longitudinal direction of the endless track **21** and the smallest dimension C_S of the cross-section of the transversal

stiffening rod 36_x is in the thickness direction of the endless track 21 . The cross-section of the transversal stiffening rod 36_x is thus elongated in the longitudinal direction of the track 21 .

[0109] The aspect ratio C_L/C_S of the cross-section of the transversal stiffening rod 36_x , which is a ratio of the longest dimension C_L of the cross-section to the smallest dimension C_S of the cross-section, can have any suitable value in various embodiments. For example, in some embodiments, the aspect ratio C_L/C_S may be at least 4, in some cases at least 5, in some cases at least 6, in some cases at least 7, in some cases at least 8, in some cases at least 10, and in some cases even more (e.g., 12, 15 or more).

[0110] In this embodiment, the cross-section of the transversal stiffening rod 36_x is substantially flat. That is, the cross-section of the rod 36_x has major surfaces generally parallel to one another and distinctly larger than its minor surfaces.

[0111] More particularly, in this embodiment, the cross-section of the transversal stiffening rod 36_x is oblong. More specifically, in this embodiment, the cross-section of the transversal stiffening rod 36_x has a generally oblong rectangular shape. A width W_R of the cross-section of the transversal stiffening rod 36_x is in the longitudinal direction of the endless track 21 , and corresponds to the longest dimension C_L of the cross-section. A thickness T_R of the cross-section of the transversal stiffening rod 36_x is in the thickness direction of the endless track 21 , and corresponds to the smallest dimension C_S of the cross-section. In this example, the aspect ratio W_R/T_R is about 8. In view of the generally oblong rectangular shape and thinness of its cross-section, in this example, the transversal stiffening rod 36_x is plate-like and similar to a ruler and can be referred to as a “plate-like” or “ruler” rod.

[0112] Also, in this embodiment, the cross-section of the transversal stiffening rod 36_x is constant (i.e., does not substantially change) along at least a majority of a length of the rod 36_x . More particularly, in this example, the cross-section of the transversal stiffening rod 36_x is constant along an entirety of the length of the rod 36_x . In other embodiments, the cross-section of the transversal stiffening rod 36_x may vary along the longitudinal axis 86 of the rod 36_x such that it is different (e.g., larger, smaller, and/or differently shaped) at respective locations along the longitudinal axis 86 of the rod 36_x .

[0113] The cross-section of each of the transversal stiffening rods 36_1 - 36_N may have various other shapes such that it is elongate, i.e., its aspect ratio C_L/C_S is high, in other embodiments. For example, in other embodiments, the cross-section of a transversal stiffening rod 36_x may be oblong but not rectangular (e.g., it may be oblong with bent, curved or pointy lateral edges).

1.1.2 Thin Rod

[0114] In some embodiments, as shown in FIGS. 12 and 13, a transversal stiffening rod 36_x may be “thin”, i.e., the thickness T_R of the cross-section of the transversal stiffening rod 36_x in the thickness direction of the endless track 21 may be small. In some cases, this can happen with the cross-section of the transversal stiffening rod 36_x being elongate, i.e., having a high aspect ratio C_L/C_S , as discussed above in section 1.1.1. In other cases, this can happen without the cross-section of the transversal stiffening rod 36_x being elongate, i.e., having a high aspect ratio C_L/C_S .

[0115] The thickness T_R can have any suitable value. For example, in some embodiments, the thickness T_R may be less than 3.5 mm, in some cases no more than 3 mm, in some cases no more than 2.5 mm, in some cases no more than 2 mm, and in some cases even less (e.g., 1.5 mm or less).

[0116] The thickness T_R of the cross-section of the transversal stiffening rod 36_x can also be expressed relative to the thickness T_C of the carcass 35 . For example, in some embodiments, a ratio T_R/T_C of the thickness T_R of the cross-section of the transversal stiffening rod 36_x to the thickness T_C of the carcass 35 may be less than 0.7, in some cases no more than 0.6, in some cases no more than 0.5, in some cases no more than 0.4, and in some cases even less (e.g., 0.2 or less).

[0117] In this embodiment, the cross-section of the transversal stiffening rod 36_x is generally semicircular or half-moon-shaped. The thickness T_R thus generally corresponds to a radius of the cross-section of the transversal stiffening rod 36_x . Hence, in this embodiment, the transversal stiffening rod 36_x is thin but its cross-section does not have a high aspect ratio C_L/C_S as discussed above in section 1.1.1.

[0118] The cross-section of each of the transversal stiffening rods 36_1 - 36_N may have various other shapes such that its thickness T_R is small in other embodiments. For example, in other embodiments, the cross-section of a transversal stiffening rod 36_x may be generally circular, square, oblong rectangular, etc.

1.1.3 Rod Defining an Internal Space

[0119] In some embodiments, as shown in FIGS. 14 and 15, a transversal stiffening rod 36_x may form a cavity (i.e., an internal space) 44 which, in this example, receives elastomeric material 46 . In this embodiment, the cavity 44 is open toward the inner side 25 of the endless track 21 in order to increase a thickness of elastomeric material between the transversal stiffening rod 36_x and the inner side 25 of the track 21 . The elastomeric material 46 , which is a portion of the elastomeric material 38 of the carcass 35 , is thus located between the transversal stiffening rod 36_x and the inner surface 32 of the carcass 35 .

[0120] More particularly, in this embodiment, the transversal stiffening rod 36_x forms the cavity 44 by having a cross-section that is curved. In this example, the cross-section of the transversal stiffening rod 36_x is generally arc-shaped. In addition to the increase in the thickness of elastomeric material, this shape may make the transversal stiffening rod 36_x more rigid (e.g., compared to a plate-like rod as discussed above in section 1.1.1).

[0121] The cross-section of the transversal stiffening rod 36_x may have various other shapes which define the cavity 44 in other embodiments. For instance, in some embodiments, the cross-section of the transversal stiffening rod 36_x may have other curvatures, may have straight segments, or may have a combination of straight segments and curved segments to define the cavity 44 .

[0122] FIGS. 16 and 17 show another embodiment in which the cavity 44 is closed around the cross-section of the transversal stiffening rod 36_x . Basically, the transversal stiffening rod 36_x is hollow and has the elastomeric material 46 in its hollow interior. In this embodiment, the cross-section of the transversal stiffening rod 36_x has a generally semicircular outer wall and the cavity 44 is also generally

semicircular. The cross-section of the transversal stiffening rod 36_x and the cavity 44 may have various other shapes in other embodiments.

[0123] The transversal stiffening rod 36_x with the cavity 44 may be made using various processes. For example, in some embodiments, the transversal stiffening rod 36_x may be extruded using an extrusion process or pultruded using a pultrusion process. The elastomeric material 46 may be provided in the cavity 46 by having some of the elastomeric material 38 of the carcass 35 migrate in the cavity 46 during molding of the track 21 (e.g., in cases where the cavity 44 is open as in FIGS. 14 and 15), or by placing a piece of elastomeric material in the cavity 44 of before molding of the track 21 (e.g., in cases where the cavity 44 is closed as in FIGS. 16 and 17).

[0124] As a variant to having elastomeric material 46 in the cavity 44 of a transversal stiffening rod 36_x , in some embodiments, the cavity 44 may be empty or may contain material (e.g., a fluid) other than elastomeric material. In some cases, this may involve the cavity 44 being closed not only around the cross-section of the transversal stiffening rod 36_x but also at both longitudinal ends of the transversal stiffening rod 36_x .

1.1.4 Rod Including a Recess at Idler Wheel Path

[0125] In some embodiments, as shown in FIG. 18 , a transversal stiffening rod 36_x may comprise a plurality of recesses 51_1 - 51_4 aligned with respective ones of the idler wheel paths 50_1 - 50_4 . That is, the recesses 51_1 - 51_4 are located in the widthwise direction of the endless track 21 where the idler wheel paths 50_1 - 50_4 are located, i.e., each of these recesses overlaps a respective one of the idler wheel paths 50_1 - 50_4 in the widthwise direction of the track 21 . Each recess 51_i is defined by an inner surface of the transversal stiffening rod 36_x that recedes towards the ground-engaging outer side 27 of the endless track 21 . This results in the thickness of elastomeric material between the transversal stiffening rod 36_x and the idler wheel path 50_i being greater than the thickness of elastomeric material between the transversal stiffening rod 36_x and a portion of the inner surface 32 of the carcass 35 outside of the idler wheel paths 50_1 - 50_4 .

[0126] The recess 51_i has a depth Dr that may have any suitable value in various embodiments. For example, in some embodiments, the depth Dr may be at least 0.03 inches, in some cases at least 0.045 inches, in some cases at least 0.06 inches, and in some cases even more (e.g., up to 0.125 inches).

[0127] The depth Dr of the recess 51_i can also be expressed relative to the thickness T_R of the transversal stiffening rod 36_x . For example, in some embodiments, a ratio Dr/T_R of the depth Dr of the recess 51_i to the thickness T_R of the transversal stiffening rod 36_x may be at least 0.1, in some cases at least 0.15, in some cases at least 0.2, and in some cases even more (e.g., up to 0.8).

[0128] In this embodiment, the recess 51_i is defined by a dimensional reduction of the cross-section of the transversal stiffening rod 36_x . In cases where the transversal stiffening rod 36_x is molded, the recess 51_1 may be molded during molding of the transversal stiffening rod 36_x or may be cut or otherwise formed after molding of the transversal stiffening rod 36_x .

[0129] FIG. 19 shows another embodiment in which the recess 51_i is defined by a deflection of the transversal

stiffening rod 36_x . More particularly, in this embodiment, the transversal stiffening rod 36_x is curved towards the ground-engaging outer side 27 of the track 21 to define the recess 51_1 . The transversal stiffening rod 36_x may be deflected in various other manners in other embodiments to define the recess 51_i (e.g., have a V-shaped bent). In cases where the transversal stiffening rod 36_x is molded, the deflection of the transversal stiffening rod 36_x which defines the recess 51_i may be created during molding of the transversal stiffening rod 36_x .

1.1.5 Thickness of Elastomeric Material Between Rod Inner Surface and Carcass Inner Surface Varying Longitudinally

[0130] In some embodiments, as shown in FIGS. $20A$ and 21 , a transversal stiffening rod 36_x may be shaped such that a thickness of elastomeric material T_{IR} between an inner surface 52 of the transversal stiffening rod 36_x (i.e., a surface of the transversal stiffening rod 36_x facing the inner side 25 of the track 21) and the inner surface 32 of the carcass 35 varies in the longitudinal direction of the track 21 .

[0131] In this case, the thickness of elastomeric material T_{IR} decreases in the longitudinal direction of the track 21 along a direction of motion of the roller wheels 28_1 - 28_6 , 30_1 , 30_2 when the snowmobile 10 travels forward. This may help to reduce an intensity of a shock when a given one of the roller wheels 28_1 - 28_6 , 30_1 , 30_2 arrives at the transversal stiffening rod 36_x . Basically, a transition of the roller wheel between a relatively soft region of the track 21 before the transversal stiffening rod 36_x and a relatively hard region of the track at the transversal stiffening rod 36_x is made progressively.

[0132] A variation ΔT_{IR} of the thickness of elastomeric material T_{IR} across a dimension L_R of the cross-section of the transversal stiffening rod 36_x in the longitudinal direction of the track 21 may have any suitable value in various embodiments. The variation ΔT_{IR} can be calculated $\Delta T_{IR} = (T_{IR-max} - T_{IR-min})/T_{IR-min} \times 100\%$, where T_{IR-max} and T_{IR-min} are respectively the maximum and minimum values of the thickness of elastomeric material T_{IR} across the dimension L_R of the cross-section of the transversal stiffening rod 36_x . For example, in some embodiments, the variation ΔT_{IR} may be at least 10%, in some cases at least 30%, in some cases at least 50%, and in some cases even more (e.g., up to 100%).

[0133] In this embodiment, the cross-section of the transversal stiffening rod 36_x has a wedge-like shape such that the thickness of elastomeric material T_{IR} progressively decreases across its dimension L_R .

[0134] FIG. $20B$ shows another embodiment in which the inner surface 52 of a transversal stiffening rod 36_x is uneven such that the thickness of elastomeric material T_{IR} between the inner surface 52 of the transversal stiffening rod 36_x and the inner surface 32 of the carcass 35 varies in the longitudinal direction of the track 21 . In this embodiment, the inner surface 52 of the transversal stiffening rod 36_x is curved. More particularly, in this example, the cross-section of the transversal stiffening rod 36_x is generally semicircular or half-moon-shaped with the inner surface 52 being arched.

[0135] The cross-section of the transversal stiffening rod 36_x may have various other shapes to create the variation ΔT_{IR} of the thickness of elastomeric material T_{IR} in other embodiments.

1.2 Short Rods

[0136] In some embodiments, as shown in FIG. 36, a transversal stiffening rod 36_x may be a “short” rod that does not extend across all the width of the endless track 21 such that it does not extend beneath laterally-outmost track-contacting devices of the track-engaging assembly 24, i.e., laterally-outmost ones of the idler wheels 26_1 - 26_4 , 28_1 - 28_5 , 30_1 , 30_2 (i.e., those idler wheels which are closest to lateral edges of the track 21) and/or the slide rails 33_1 , 33_2 . This may avoid impacts that would otherwise occur between the transversal stiffening rod 36_x and these wheels and/or slide rails and may therefore reduce noise generation.

[0137] A ratio of the length of the transversal stiffening rod 36_x to the width of the track 21 may have any suitable value. For example, in some embodiments, the ratio of the length of the transversal stiffening rod 36_x to the width of the track 21 may be no more than 90%, in some cases no more than 85%, in some cases no more than 80%, and in some cases even less (e.g., no more than 50%).

[0138] In this embodiment, the transversal stiffening rod 36_x extends beneath the slide rails 33_1 , 33_2 but does not extend beneath the idler wheels 26_1 , 26_4 , 28_1 , 28_2 , 28_4 , 28_5 which are laterally outmost (only the idler wheels 28_1 , 28_4 are shown here). In other embodiments, the transversal stiffening rod 36_x may be shorter. For instance, FIG. 37 shows an embodiment in which the transversal stiffening rod 36_x does not extend beneath the slide rails 33_1 , 33_2 or the idler wheels 26_1 , 26_4 , 28_1 , 28_2 , 28_4 , 28_5 which are laterally outmost.

2. Distribution of Transversal Stiffening Rods

[0139] In some embodiments, a distribution of the transversal stiffening rods 36_1 - 36_N within the endless track 21 may help to reduce noise generation and/or provide other benefits (e.g., controlled transversal rigidity, etc.). Various distributions of the transversal stiffening rods 36_1 - 36_N can be implemented in various embodiments, examples of which are discussed below.

2.1 Rods Stacked in Thickness Direction of Track

[0140] In some embodiments, as shown in FIG. 22A, two or more of the transversal stiffening rods 36_1 - 36_N may be stacked in the thickness direction of the endless track 21 with deformable material 53 in between. That is, two or more of the transversal stiffening rods 36_1 - 36_N may be spaced apart in the track’s thickness direction with deformable material 53 in between them. This provides enhanced transversal rigidity but also, by virtue of the deformable material 53, shock absorption, which may help to reduce noise generation.

[0141] In this embodiment, a first transversal stiffening rod 36_i and a second transversal stiffening rod 36_j are spaced apart in the thickness direction of the track 21 and the deformable material 53 between them comprises elastomeric material. In this example of implementation, the elastomeric material 53 is rubber. The elastomeric material 53 may be another elastomer in other examples of implementation.

[0142] In some cases, the rubber 53 between the transversal stiffening rods 36_i , 36_j may have the same elasticity and/or the same hardness as other elastomeric material of the endless track 21 (e.g., a portion of the elastomeric material 38 of the carcass 35 above the transversal stiffening rod 36_i or a portion of the elastomeric material 41 of the traction projection 58_i below the transversal stiffening rod 36_i).

or a portion of the elastomeric material 41 of the traction projection 58_i below the transversal stiffening rod 36_j).

[0143] In other cases, the rubber 53 between the transversal stiffening rods 36_i , 36_j may be more elastic, i.e., have a lower modulus of elasticity, and/or less hard, i.e., a lower hardness, than other elastomeric material of the endless track 21 (e.g., a portion of the elastomeric material 38 of the carcass 35 above the transversal stiffening rod 36_j or a portion of the elastomeric material 41 of the traction projection 58_i below the transversal stiffening rod 36_i). This may help in terms of shock absorption. For example, in some embodiments, a ratio of the modulus of elasticity of the rubber 53 between the transversal stiffening rods 36_i , 36_j and the modulus of elasticity of a portion of the elastomeric material 38 of the carcass 35 above the transversal stiffening rod 36_j or a portion of the elastomeric material 41 of the traction projection 58_i below the transversal stiffening rod 36_i may be no more than 0.9, in some cases no more than 0.8, in some cases no more than 0.7, and in some cases even less (e.g., no more than 0.5); and/or a ratio of the hardness of the rubber 53 between the transversal stiffening rods 36_i , 36_j and the hardness of a portion of the elastomeric material 38 of the carcass 35 above the transversal stiffening rod 36_j or a portion of the elastomeric material 41 of the traction projection 58_i below the transversal stiffening rod 36_i may be no more than 0.9, in some cases no more than 0.8, in some cases no more than 0.7, and in some cases even less (e.g., no more than 0.5).

[0144] In other cases, the rubber 53 between the transversal stiffening rods 36_i , 36_j may be more rigid, i.e., have a higher modulus of elasticity, and/or harder, i.e., a higher hardness, than other elastomeric material of the endless track 21 (e.g., a portion of the elastomeric material 38 of the carcass 35 above the transversal stiffening rod 36_j or a portion of the elastomeric material 41 of the traction projection 58_i below the transversal stiffening rod 36_i). This may help in terms of transverse rigidity. For example, in some embodiments, a ratio of the modulus of elasticity of the rubber 53 between the transversal stiffening rods 36_i , 36_j and the modulus of elasticity of a portion of the elastomeric material 38 of the carcass 35 above the transversal stiffening rod 36_j or a portion of the elastomeric material 41 of the traction projection 58_i below the transversal stiffening rod 36_i may be at least 1.1, in some cases at least 1.2, in some cases at least 1.3, and in some cases even more (e.g., at least 1.5); and/or a ratio of the hardness of the rubber 53 between the transversal stiffening rods 36_i , 36_j and the hardness of a portion of the elastomeric material 38 of the carcass 35 above the transversal stiffening rod 36_j or a portion of the elastomeric material 41 of the traction projection 58_i below the transversal stiffening rod 36_i may be at least 1.1, in some cases at least 1.2, in some cases at least 1.3, and in some cases even more (e.g., at least 1.5).

[0145] A spacing S_{RT} of the transversal stiffening rods 36_i , 36_j in the thickness direction of the track 21 may have any suitable value. In this case, the spacing S_{RT} corresponds to a thickness of the rubber 53. For example, in some embodiments, the spacing S_{RT} may be at least 0.030 inches, in some cases at least 0.060 inches, in some cases at least 0.125 inches, and in some cases even more.

[0146] The spacing S_{RT} of the transversal stiffening rods 36_i , 36_j in the thickness direction of the track 21 can also be expressed relative to the thickness T_C of the carcass 35. For example, in some embodiments, a ratio S_{RT}/T_C of the

spacing S_{RT} of the transversal stiffening rods $36_i, 36_j$ to the thickness T_C of the carcass 35 may be at least 0.15, in some cases at least 0.30, in some cases at least 0.60, and in some cases even more.

[0147] The deformable material 53 can be positioned between the transversal stiffening rods $36_i, 36_j$ during manufacturing of the endless track 21 in various ways. For example, in embodiments in which the endless track 21 is molded in a mold by placing different layers of material in the mold, the deformable material 53 may be positioned over the transversal stiffening rod 36_i in the mold before placing the transversal stiffening rod 36_j in the mold, or vice versa.

[0148] In this embodiment, each of the transversal stiffening rods $36_i, 36_j$ has a cross-section with a high aspect ratio and a generally rectangular shape, i.e., it is a plate-like or “ruler” rod, as discussed above in section 1.1.1. The transversal stiffening rods $36_i, 36_j$ may have any other suitable shapes in other embodiments. Also, in some embodiments, the transversal stiffening rods $36_i, 36_j$ may have a common shape, while in other embodiments, they may have different shapes.

[0149] Although in this embodiment the deformable material 53 between the transversal stiffening rods $36_i, 36_j$ comprises elastomeric material, in other embodiments, the deformable material 53 may comprise any other deformable substance. For example, in some embodiments, the deformable material 53 may comprise a gel, a fluid (e.g., a pouch or other container containing a liquid or gas), or another substance that can deform under load.

[0150] Also, in some embodiments, one or more of the reinforcing cables 37_1-37_M and/or a layer of reinforcing fabric 43 of the track 21 may extend between the transversal stiffening rods $36_i, 36_j$ stacked over one another. For example, FIG. 22B shows an embodiment in which a reinforcing cable 37_i extends between the transversal stiffening rods $36_i, 36_j$, while FIG. 22C shows an embodiment in which a layer of reinforcing fabric 43 extends between the transversal stiffening rods $36_i, 36_j$.

[0151] While in this embodiment there are two transversal stiffening rods $36_i, 36_j$ stacked over one another, in other embodiments, there may be three or more of the transversal stiffening rods 36_1-36_N that are stacked in the thickness direction of the track 21 with deformable material 53 between adjacent ones of these three or more transversal stiffening rods.

2.2 Rods Located Between Longitudinally-Adjacent Traction Projections

[0152] In some embodiments, as shown in FIG. 23A, in addition to given ones of the transversal stiffening rods 36_1-36_N being aligned with respective ones of the traction projections 58_1-58_T in the longitudinal direction of the track 21 (i.e., being located, in the longitudinal direction of the track 21 , where respective ones of the traction projections 58_1-58_T are located such that a stiffening rod overlaps a traction projection in the longitudinal direction of the track 21), other ones of the transversal stiffening rods 36_1-36_N may be located, in the longitudinal direction of the track 21 , between adjacent ones of the traction projections 58_1-58_T . This may provide enhanced transversal rigidity while not being detrimental in terms of noise generation. For example, in some cases, the idler wheels $28_1-28_6, 30_1, 30_2$ spending more time on relatively rigid parts of the track 21 as they move along respective ones of the rolling paths 50_1-50_4 of

the inner surface 32 of the carcass 35 may help to reduce noise generation. In other cases, the transversal stiffening rods 36_1-36_N may be shaped such that noise generated is not greater than if there were rods only where the traction projections 58_1-58_T are located.

[0153] More particularly, in this embodiment, a transversal stiffening rod 36_x is located longitudinally between a first traction projection 58_i and a second traction projection 58_j that are adjacent to one another in the longitudinal direction of the track 21 . The transversal stiffening rod 36_x is also located longitudinally between a first transversal stiffening rod 36_i and a second transversal stiffening rod 36_j which are respectively located, in the longitudinal direction of the track 21 , where the traction projections $58_i, 58_j$ are located. A distance PT between the traction projections $58_i, 58_j$ along the longitudinal direction of the track 21 is referred to as a “pitch”. In view of its longitudinal position, the transversal stiffening rod 36_x may be referred to as an “inter-traction-projection” rod or an “interpitch” rod.

[0154] In this example, the transversal stiffening rod 36_x is located midway between the traction projections $58_i, 58_j$. In other examples, the transversal stiffening rod 36_x may be located closer to a given one of the traction projections $58_i, 58_j$ than the other.

[0155] In this embodiment, each of the transversal stiffening rods $36_x, 36_i, 36_j$ has a cross-section with a high aspect ratio and a generally rectangular shape, i.e., it is a plate-like or “ruler” rod, as discussed above in section 1.1.1. The longitudinal extent of each of the transversal stiffening rods $36_x, 36_i, 36_j$ results in the roller wheels $28_1-28_6, 30_1, 30_2$ spending even more time on relatively rigid parts of the track 21 as they move along respective ones of the rolling paths 50_1-50_4 of the inner surface 32 of the carcass 35 . Also, the thinness of the transversal stiffening rod 36_x allows it to be entirely embedded in the carcass 35 between the traction projections $58_i, 58_j$.

[0156] Each of the transversal stiffening rods $36_x, 36_i, 36_j$ may have any other suitable shape in other embodiments. Also, different ones of the transversal stiffening rods $36_x, 36_i, 36_j$ may have different shapes in other embodiments. For example, in some embodiments, the transversal stiffening rods $36_i, 36_j$ may have a common shape while the transversal stiffening rod 36_x may have a different shape. For instance, FIG. 23B shows an embodiment in which the transversal stiffening rods $36_i, 36_j$ are thicker and thus more rigid than the transversal stiffening rod 36_x since there is more rubber where they are located.

[0157] Although in this embodiment there is a single inter-traction-projection rod 36_x between the adjacent traction projections $58_i, 58_j$, in other embodiments, there may be two or more inter-traction-projection rods between the traction projections $58_i, 58_j$. For instance, FIG. 24 shows an embodiment in which there are two inter-traction-projection rods $36_{x1}, 36_{x2}$ between the traction projections $58_i, 58_j$.

2.3 Longitudinally-Adjacent Rods have at Least One Different Characteristic

[0158] In some embodiments, as shown in FIG. 25, longitudinally-adjacent ones of the transversal stiffening rods 36_1-36_N may be different from one another, i.e., may have at least one characteristic, such as shape or material, that is different. This may help to reduce noise generation by creating a sound spectrum which is different from that which would result if all the transversal stiffening rods 36_1-36_N were identical.

[0159] In this embodiment, a first transversal stiffening rod 36_i , and a second transversal stiffening rod 36_j , which are adjacent to one another in the longitudinal direction of the endless track 21 have different shapes. In this example, the transversal stiffening rod 36_i has a generally rectangular cross-section (as discussed above in section 1.1.1), while the transversal stiffening rod 36_j has a generally semicircular cross-section. The transversal stiffening rods 36_i , 36_j may have any other suitable shapes that are different from one another in other examples (e.g., the transversal stiffening rods 36_i , 36_j and the transversal stiffening rod 36_x discussed in connection with FIG. 23B).

[0160] Also, in this embodiment, the transversal stiffening rods 36_i , 36_j comprise different materials. For example, in this case, the transversal stiffening rod 36_i may be made of material which is more rigid than material from which is made the transversal stiffening rod 36_j , given its smaller cross-sectional size.

[0161] While in this embodiment the transversal stiffening rods 36_i , 36_j differ both in shape and material, in other embodiments, the transversal stiffening rods 36_i , 36_j may differ only in shape or only in material.

[0162] Also, although in this embodiment, only two adjacent transversal stiffening rods 36_i , 36_j have been considered, in some embodiments, three or more of the stiffening rods 36_1 - 36_N which succeed one another in the longitudinal direction of the track 21 may be different from one another (e.g., have three or more different shapes and/or comprise three or more different materials).

3. Material of Transversal Stiffening Rod

[0163] In some embodiments, a transversal stiffening rod 36_x may be made of material which may help to reduce noise generation and/or provide other benefits (e.g., controlled transversal rigidity, etc.). For example, in some embodiments, the material of the transversal stiffening rod 36_x may be selected so as to provide transversal rigidity yet reduce the difference in thickness-wise hardness or rigidity between a region of the endless track 21 where the transversal stiffening rod 36_x is located and adjacent regions of the endless track 21 where there are no transversal stiffening rods. This may help to reduce an intensity of a shock when a given one of the roller wheels 28_1 - 28_6 , 30_1 , 30_2 arrives at the transversal stiffening rod 36_x .

3.1 Reinforced Elastomeric Rod

[0164] In some embodiments, as shown in FIG. 26, a transversal stiffening rod 36_x may be an elastomeric fiber-reinforced rod which comprises an elongated elastomeric body 55 in which are embedded fibers 56_1 - 56_F (which indicates any number of embedded fibers, 56_1 , 56_2 . . . to 56_F). The fibers 56_1 - 56_F generally extend transversally to the longitudinal direction of the track 21 to provide transversal rigidity to the transversal stiffening rod 36_x .

[0165] The elongated elastomeric body 55 is elastomeric in that it comprises elastomeric material 57 . The elastomeric material 57 can be any polymeric material with suitable elasticity. More particularly, in this embodiment, the elastomeric material 57 includes rubber. Various rubber compounds may be used and, in some cases, different rubber compounds may be present in different areas of each of the elongated elastomeric body 55 . In other embodiments, the

elastomeric material 57 may include another elastomer in addition to or instead of rubber (e.g., polyurethane elastomer).

[0166] In some cases, the rubber 57 of the transversal stiffening rod 36_x may be more rigid and/or harder than the elastomeric material 38 or 41 of the track 21 in contiguous regions of the track 21 where there is no transversal stiffening rod. For example, in some embodiments, the rubber 57 of the transversal stiffening rod 36_x may be less elastic, i.e., have a higher modulus of elasticity, and/or harder, i.e., have a higher hardness, than the elastomeric material 38 or 41 of the track 21 in contiguous regions of the track 21 where there is no transversal stiffening rod.

[0167] In other cases, the rubber 57 of the transversal stiffening rod 36_x may be less rigid and/or less hard than the elastomeric material 38 or 41 of the track 21 in contiguous regions of the track 21 where there is no transversal stiffening rod. For example, in some embodiments, the rubber 57 of the transversal stiffening rod 36_x may be more elastic, i.e., have a lower modulus of elasticity, and/or less hard, i.e., have a lower hardness, than the elastomeric material 38 or 41 of the track 21 in contiguous regions of the track 21 where there is no transversal stiffening rod.

[0168] For example, in some embodiments, a ratio of the modulus of elasticity of the rubber 57 of the transversal stiffening rod 36_x to the modulus of elasticity of the elastomeric material 38 or 41 of the track 21 in contiguous regions of the track 21 where there is no transversal stiffening rod may be at least 0.75, in some cases at least 1, and in some cases at least 1.1, and in some cases even more. Alternatively or additionally, in some embodiments, a ratio of the hardness of the rubber 57 of the transversal stiffening rod 36_x to the hardness of the elastomeric material 38 or 41 of the track 21 in contiguous regions of the track 21 where there is no transversal stiffening rod may be at least 0.75, in some cases at least 1, in some cases at least 1.1, and in some cases even more.

[0169] For instance, in some embodiments, the hardness of the rubber 57 of the transversal stiffening rod 36_x may be at least 60 durometers A, in some cases at least 80 durometers A, in some cases at least 90 durometers A, and in some cases even more. The hardness of the rubber 57 of the transversal stiffening rod 36_x may have any other suitable value in other embodiments.

[0170] The fibers 56_1 - 56_F may be implemented in various manners. In this embodiment, each of the fibers 56_1 - 56_F extends along at least a majority of a length of the transversal stiffening rod 36_x . More particularly, in this case, each of the fibers 56_1 - 56_F extends along all of the length of the transversal stiffening rod 36_x . In other embodiments, each of the fibers 56_1 - 56_F may be shorter. For example, in other embodiments, the fibers 56_1 - 56_F may be “chopped” or otherwise cut fibers which are few millimeters or centimeters long and are distributed throughout the transversal stiffening rod 36_x .

[0171] In this embodiment, the fibers 56_1 - 56_F are polymeric fibers. More specifically, in this example, the fibers 56_1 - 56_F are aramid fibers. Various other types of polymeric fibers may be used in other examples (e.g., polyvinyl alcohol (PVA) fibers). Also, in other embodiments, the fibers 56_1 - 56_F may be any other suitable type of fibers (e.g., metallic fibers, carbon fibers, glass fibers, etc.).

[0172] The transversal stiffening rod 36_x may be manufactured using various techniques. For example, in some

embodiments, the transversal stiffening rod 36_x may be manufactured using an extrusion process or a pultrusion process in which the fibers 56_1 - 56_F are incorporated during extrusion or pultrusion of the elongated elastomeric body 55 of the rod. In other embodiments, the elongated elastomeric body 55 of the rod may be molded with the fibers 56_1 - 56_F inside a mold. For instance, two or more strips or other suitably-sized pieces of rubber reinforced with the fibers 56_1 - 56_F having a width generally corresponding to that of the transversal stiffening rod 36_x may be cut from calendared fiber-reinforced rubber and layered on top of one another such that, during molding, they form the transversal stiffening rod 36_x .

3.2 Rod Made of Composite Material

[0173] In some embodiments, a transversal stiffening rod 36_x may be made of composite material. For instance, in some embodiments, a transversal stiffening rod 36_x may be made of a carbon fiber reinforced plastic material.

4. Zones with Different Elastomeric Material Properties

[0174] In some embodiments, elastomeric material of certain zones of the endless track 21 may have different hardness and/or different elasticity in order to reduce noise generation and/or provide other benefits (e.g., controlled rigidity). Various zones with different hardness and/or elasticity can be implemented in various embodiments, examples of which are discussed below.

4.1 Hardness and/or Modulus of Elasticity of Elastomeric Material of Ground-Engaging Outer Side is Lower than Hardness and/or Modulus of Elasticity of Elastomeric Material of Carcass

[0175] In some embodiments, as shown in FIG. 27, the hardness and/or the modulus of elasticity of elastomeric material of the ground-engaging outer side 27 of the endless track 21 may be lower than the hardness and/or the modulus of elasticity of the elastomeric material 38 of the carcass 35 of the track 21 . This may help to reduce noise generated.

[0176] More particularly, in this embodiment, the hardness and/or the modulus of elasticity of the rubber 41 of a traction projection 58_x is lower than the hardness and/or the modulus of elasticity of the rubber 38 of the carcass 35 . For example, in some embodiments, a ratio of the hardness of the rubber 41 of the traction projection 58_x to the hardness of the rubber 38 of the carcass 35 may be no more than 0.9, in some cases no more than 0.8, and in some cases no more than 0.7. The hardness of the rubber 41 of the traction projection 58_x may have any other suitable value in other embodiments.

[0177] In embodiments where the rubber 38 of the carcass 35 is constituted of a single rubber compound, the hardness of the rubber 38 is that of the single rubber compound. In embodiments where the rubber 38 of the carcass 35 is constituted of two or more rubber compounds, the hardness of the rubber 38 is the average hardness determined based on the hardness of each of these constituent rubber compounds and their proportions (as discussed previously).

[0178] In some cases, in embodiments where the rubber 38 of the carcass 35 is constituted of two or more rubber compounds, the hardness of the rubber 41 of the traction projection 58_x may be lower than the hardness of an outer layer of the rubber 38 of the carcass 35 which forms the ground-engaging outer surface 31 of the carcass 35 .

[0179] As another example, in some embodiments, a ratio of the modulus of elasticity of the rubber 41 of the traction

projection 58_x to the modulus of elasticity of the rubber 38 of the carcass 35 may be no more than 0.9, in some cases no more than 0.8, and in some cases no more than 0.7. The modulus of elasticity of the rubber 41 of the traction projection 58_x may have any other suitable value in other embodiments.

[0180] In embodiments where the rubber 38 of the carcass 35 is constituted of a single rubber compound, the modulus of elasticity of the rubber 38 is that of the single rubber compound. In embodiments where the rubber 38 of the carcass 35 is constituted of two or more rubber compounds, the modulus of elasticity of the rubber 38 is the average modulus of elasticity determined based on the modulus of elasticity of each of these constituent rubber compounds and their proportions (as discussed previously).

[0181] In some cases, in embodiments where the rubber 38 of the carcass 35 is constituted of two or more rubber compounds, the modulus of elasticity of the rubber 41 of the traction projection 58_x may be lower than the modulus of elasticity of the outer layer of the rubber 38 of the carcass 35 which forms the ground-engaging outer surface 31 of the carcass 35 .

4.2 Hardness and/or Modulus of Elasticity of Elastomeric Material at Widthwise Position of Idler Wheel Path is Lower than Hardness and/or Modulus of Elasticity of Elastomeric Material at Widthwise Position Outside of Idler Wheel Path

[0182] In some embodiments, as shown in FIG. 28, elastomeric material 59 of the endless track 21 at a widthwise position of an idler wheel path 50_i may be less hard and/or more elastic than elastomeric material 60 of the endless track 21 at a widthwise position outside every idler wheel path. This forms a “shock absorption zone” that provides shock absorption, and thus reduces noise generation, when a given one of the idler wheels 26_1 - 26_n , 28_1 - 28_n , 30_1 , 30_2 which runs on the idler wheel path 50_i crosses the transversal stiffening rods 36_1 - 36_n . This is an example of an embodiment in which a shock absorbency (i.e., a capacity to absorb shocks) of the track 21 at the widthwise position of the idler wheel path 50_i is greater than a shock absorbency of the track 21 at a widthwise position outside the idler wheel path 50_i .

[0183] More particularly, in this embodiment, the elastomeric material 59 and the elastomeric material 60 are adjacent portions of the rubber 38 of the carcass 35 . In this example, the rubber 59 extends outwardly in the thickness direction of the track 21 from the inner surface 32 of the carcass 35 . The elastomeric material 59 may have any suitable thickness. For instance, in some cases, the thickness of the rubber 59 may correspond to at least 10% of the thickness T_C of the carcass 35 , in some cases at least 20% of the thickness T_C of the carcass 35 , in some cases at least 30% of the thickness T_C of the carcass 35 , in some cases at least 40% of the thickness T_C of the carcass, and in some cases even more. In some cases, the rubber 59 may extend from the inner surface 32 to the ground-engaging outer surface 31 of the carcass 35 , i.e., the thickness of the rubber 59 may correspond to the thickness T_C of the carcass 35 .

[0184] As an example, in some embodiments, a ratio of the hardness of the rubber 59 at the widthwise position of the idler wheel path 50_i to the hardness of the rubber 60 at a widthwise position outside of every idler wheel path may be no more than 0.9, in some cases no more than 0.8, in some cases no more than 0.7, and in some cases even less (e.g., no more than 0.5).

[0185] For instance, in some embodiments, the hardness of the rubber 59 at the widthwise position of the rolling path 50_i may no more than 80 durometers A, in some cases no more than 70 durometers A, in some cases no more than 60 durometers A, and in some cases even less. The hardness of the rubber 59 may have any other suitable value in other embodiments.

[0186] In embodiments where the rubber 59 or 60 of the carcass 35 is constituted of a single rubber compound, the hardness of the rubber 59 or 60 is that of the single rubber compound. In embodiments where the rubber 59 or 60 of the carcass 35 is constituted of two or more rubber compounds, the hardness of the rubber 59 or 60 is the average hardness determined based on the hardness of each of these rubber compounds and their proportions (as discussed previously).

[0187] As another example, in some embodiments, a ratio of the modulus of elasticity of the rubber 59 at the widthwise position of the rolling path 50_i to the modulus of elasticity of the rubber 60 outside of every rolling path may be no more than 0.9, in some cases no more than 0.8, in some cases no more than 0.7, and in some cases even less (e.g., no more than 0.5).

[0188] In embodiments where the rubber 59 or 60 of the carcass 35 is constituted of a single rubber compound, the modulus of elasticity of the rubber 59 or 60 is that of the single rubber compound. In embodiments where the rubber 59 or 60 of the carcass 35 is constituted of two or more rubber compounds, the modulus of elasticity of the rubber 59 or 60 is the average modulus of elasticity determined based on the modulus of elasticity of each of these rubber compounds and their proportions (as discussed previously).

[0189] While in embodiments considered above the rubber 59 forming an absorption zone extends outwardly from the inner surface 32 of the carcass 35, in other embodiments, the rubber 59 may extend inwardly from the ground-engaging outer surface 31 of the carcass 32 without reaching the inner surface 32 of the carcass 35, as shown in FIG. 29, or may be embedded in the carcass 35 without reaching either of its inner surface 32 and ground-engaging outer surface 31, as shown in FIG. 30.

[0190] FIG. 31 shows another embodiment in which elastomeric material 61 of the endless track 21 at a widthwise position of an idler wheel path 50, is less hard and/or more elastic than elastomeric material 62 of the endless track 21 at a widthwise position outside every idler wheel path. In this embodiment, the elastomeric material 61 and the elastomeric material 62 are adjacent portions of the rubber 41 of a traction projection 58_x. In some embodiments, the hardness and/or the modulus of elasticity of each of the rubber 61 and the rubber 62 may be selected as discussed above in respect of the rubber 59 or 60 of the carcass 35.

[0191] In embodiments considered above, the rubber 59 and the rubber 60 of the carcass 35, and the rubber 61 and the rubber 62 of the traction projection 58_x, may be provided during manufacturing of the endless track 21 by placing pieces of rubber (e.g., cut sheets or blocks of rubber) corresponding to these rubber portions in a mold such that, after molding, they form these rubber portions of track 21.

5. Transversal Stiffening Cables

[0192] In some embodiments, as shown in FIG. 32A, the endless track 21 may comprise a layer of transversal stiffening cables 63₁-63_T (which indicates any number of transversal stiffening cables 63₁, 63₂, 63₃ . . . to 63_T) which are

generally parallel to one another and extend transversally to the longitudinal direction of the track 21 to provide transverse rigidity. More particularly, in this embodiment, the transversal stiffening cables 63₁-63_T extend in the widthwise direction of the track 21.

[0193] The transversal stiffening cables 63₁-63_T may be any suitable type of cable. For example, in some embodiments, each of the transversal stiffening cables 63₁-63_T may be a cord including a plurality of strands (e.g., textile fibers or metallic wires). In other embodiments, each of the transversal stiffening cables 63₁-63_T may include a single strand and/or may be made of any other suitable material (e.g., metal, plastic or composite material).

[0194] The layer of transversal stiffening cables 63₁-63_T can be implemented in various ways. For example, in this embodiment, the layer of transversal stiffening cables 63₁-63_T is a layer of tire cord fabric in which the transversal stiffening cords 63₁-63_T are interlaced with longitudinal strands 68₁-68_S (which indicates any number of longitudinal strands 68₁, 68₂ . . . 68_S . . . 68_S) that run generally along the longitudinal direction of the track 21. In other embodiments, the transversal stiffening cables 63₁-63_T may not be interlaced with any other fabric members but may rather be unconnected other than by the rubber of the track 21.

[0195] In some embodiments, as shown in FIG. 32B, the track 21 may be free of transversal stiffening rods but have sufficient transversal rigidity because of the transversal stiffening cables 63₁-63_T.

[0196] In other embodiments, as shown in FIG. 32C, the track 21 may include the transversal stiffening rods 36₁-36_N along with the transversal stiffening cables 63₁-63_T. In some examples of implementation, the transversal stiffening rods 36₁-36_N may be smaller than conventional rods since the transversal stiffening cables 63₁-63_T assist in providing transversal rigidity. For instance, in this case, each of the transversal stiffening rods 36₁-36_N has a cross-section with a high aspect ratio and a generally rectangular shape, i.e., it is a plate-like or “ruler” rod, as discussed above in section 1.1.1. The transversal stiffening rods 36₁-36_N may have any other suitable shapes in other embodiments. Also, in this example, the layer of transversal stiffening cables 63₁-63_T is located between the transversal stiffening rods 36₁-36_N and the ground-engaging outer side 27 of the track 21. In other examples, the layer of transversal stiffening cables 63₁-63_T may be located between the transversal stiffening rods 36₁-36_N and the inner side 25 of the track 21.

[0197] In this case, the transversal stiffening rods 36₁-36_N are distributed in the track 21 such that there is one transversal stiffening rod 36_i beneath every traction projection 58_i of the track 21. In other words, a longitudinal spacing or pitch of the transversal stiffening rods 36₁-36_N may correspond to a longitudinal spacing or pitch of the traction projection 58₁-58_T.

[0198] In other cases, as shown in FIG. 32D, the transversal stiffening rods 36₁-36_N may be distributed in the track 21 such that there is no transversal stiffening rod 36_i beneath at least some of the traction projection 58₁-58_T of the track 21. In such cases, the longitudinal spacing or pitch of the transversal stiffening rods 36₁-36_N is greater than the longitudinal spacing or pitch of the traction projection 58₁-58_T. For instance, in this embodiment, there is one transversal stiffening rod 36_i at every two of the traction projections 58₁-58_T. The longitudinal spacing or pitch of the transversal stiffening rods 36₁-36_N may be even greater in other

examples (e.g., one transversal stiffening rod **36**, at every three or four of the traction projection **58₁-58₇**).

6. Carcass Periphery

[0199] In some embodiments, a periphery of the carcass **35**, including its inner surface **32** and its ground-engaging outer surface **31**, may be configured to reduce noise generation and/or provide other benefits (e.g., controlled rigidity). This can be achieved in various ways in various embodiments, examples of which will be discussed.

6.1 Idler Wheel Path Projections on Carcass Outer Surface Between Adjacent Traction Projections

[0200] In some embodiments, as shown in FIGS. **33A** and **33B**, the ground-engaging outer surface **31** of the carcass **35** may define a plurality of idler wheel path projections **64₁-64_p** (which indicates any number of path projections **64₁, 64₂, 64₃ . . . 64_p**) which are located between adjacent ones of the traction projections **58₁-58₇** in the longitudinal direction of the track and which are aligned with respective ones of the idler wheel paths **50₁-50₄** in the widthwise direction of the track **21** (i.e., overlap with respective ones of the idler wheel paths **50₁-50₄** in the widthwise direction of the track **21**). The idler wheel path projections **64₁-64_p** may help to reduce noise generation when they are crossed over by respective ones of the idler wheels **26₁-26₄, 28₁-28₆, 30₁, 30₂**.

[0201] For example, when a lower roller wheel **28_i** on a rolling path **50_i** arrives where an idler wheel rolling path projection **64_x** is located, the idler wheel rolling path projection **64_x** contacts the ground and counters a tendency of the carcass **35** to deflect downwardly under loading of the lower roller wheel **28_i**.

[0202] In this embodiment, each idler wheel rolling path projection **64_x** is uneven along the longitudinal direction of the track **21**. More particularly, in this case, the idler wheel rolling path projection **64_x** is curved along the longitudinal direction of the track **21** so that its thickness varies longitudinally.

[0203] The idler wheel path projections **64₁-64_p** may be configured in various other ways in other embodiments. For example, in some embodiments, as shown in FIGS. **34A** and **34B**, each of the idler wheel path projections **64₁-64_p** may be generally flat along the longitudinal direction of the track **21** and may occupy all of a longitudinal extent between adjacent ones of the traction projection **58₁-58₇** such that the idler wheel path projections **64₁-64_p** form “continuous” raised longitudinal bands **691-694** on the ground-engaging outer side **27** of the track **21**.

6.2 Longitudinal Rigidifiers on Carcass Inner Surface and/or Outer Surface

[0204] In some embodiments, as shown in FIGS. **38** and **39**, the inner surface **32** and/or the ground-engaging outer surface **31** of the carcass **35** of the endless track **21** may comprise a plurality of longitudinal rigidifiers **70₁-70_R** (which indicates any number of longitudinal rigidifiers **70₁, 70₂, 70₃, 70₄, 70₅ . . . 70_R**) for imparting longitudinal rigidity to the track **21**. Each of the longitudinal rigidifiers **70₁-70_R** is an elastomeric formation, such as a projection or recess, formed in the rubber of the carcass **35** that increases the longitudinal rigidity of the track **21** compared to if the track **21** lacked the longitudinal rigidifiers **70₁-70_R** but was otherwise identical. The increased longitudinal rigidity of the

track **21** may help to reduce deflection of the track **21** when the idler wheels roll on the bottom run of the track **21**.

[0205] In this embodiment, the longitudinal rigidifiers **70₁-70_R** are longitudinally-rigidifying projections formed in the inner surface **32** of the track **32**. More particularly, in this example of implementation, the longitudinally-rigidifying projections **70₁-70_R** are shaped as raised strips that are generally parallel to the longitudinal direction of the track **21**. The longitudinally-rigidifying projections **70₁-70_R** may have various other shapes (e.g., narrower ridges or ribs) and/or may have various other orientations (e.g., oblique) relative to the longitudinal direction of the track **21** in other examples of implementation. In other embodiments, instead of being projections, the longitudinal rigidifiers **70₁-70_R** may be longitudinally-rigidifying recesses (e.g., grooves that are generally parallel to the longitudinal direction of the track **21**). In yet other embodiments, the longitudinal rigidifiers **70₁-70_R** may include both longitudinally-rigidifying projections and longitudinally-rigidifying recesses.

[0206] The longitudinal rigidifiers **70₁-70_R** may be arranged in various ways. For example, in this embodiment, the longitudinal rigidifiers **70₂, 70₄** are located where the idler wheel paths **50₂, 50₃** are located while the longitudinal rigidifiers **70₁, 70₃, 70₅** are located outside of the idler wheel paths **50₁-50₄**.

[0207] Although in this embodiment the longitudinal rigidifiers **70₁-70_R** are located on the inner surface **32** of the carcass **35**, in other embodiments, similar longitudinal rigidifiers may be located on the ground-engaging outer surface **31** of the track **21** in addition to or instead of the longitudinal rigidifiers **70₁-70_R** on the inner surface **32**.

6.3 Longitudinally Uneven Idler Wheel Path

[0208] In some embodiments, as shown in FIG. **35**, an idler wheel path **50_i** on the inner surface **32** of the carcass **35** may be uneven in the longitudinal direction of the endless track **21**. For example, in this embodiment, the idler wheel path **50_i** includes a series of idler wheel path formations **671-67F** (which indicates any number of idler wheel path formations **671, 672 . . . 67F**) distributed in the longitudinal direction of the track **21**. The formations **671-67F** constitute a deformable shock-absorbing zone in the idler wheel path **50_i** such that, when idler wheels contact some of these formations **671-67F**, the formations **671-67F** can deform to absorb the shock and thus reduce noise generation. In this case, the formations **671-67F** include recesses. In other cases, the formations **671-67F** may include projections or a combination of recesses and projections. This is an example of an embodiment in which a shock absorbency (i.e., a capacity to absorb shocks) of the track **21** at the widthwise position of the idler wheel path **50_i** is greater than a shock absorbency of the track **21** at a widthwise position outside the idler wheel path **50_i**.

[0209] A longitudinal spacing of adjacent ones of the idler wheel path formations **671-67F** may be selected so as to allow proper deformability for shock absorbance yet avoid creating unwanted vibrational effects as some of the idler wheels **26₁-26₄, 28₁-28₆, 30₁, 30₂** roll over these formations **671-67F**. For example, in some embodiments, the longitudinal spacing of adjacent ones of the idler wheel path formations **671-67F** may be no more than 5 mm, in some cases no more than 4, and in some cases no more than 3 mm.

The longitudinal spacing of adjacent ones of the idler wheel path formations 671-67F may have any other suitable value in other embodiments.

7. Track Elastomeric Material

[0210] In some embodiments, elastomeric material of the track 21 may have certain characteristic which may help to reduce noise generation and/or provide other benefits (e.g., controlled rigidity).

7.1 Fiber-Reinforced Elastomeric Material

[0211] In some embodiments, as shown in FIG. 44, the track 21 may be at least mainly (i.e., entirely or mainly) made of fiber-reinforced elastomeric material which comprises an elastomeric matrix 87 in which are embedded fibers 891-89F (which indicates any number of embedded fibers 891, 892 . . . 89F). In other words, at least a bulk of the track 21 may be made of the fiber-reinforced elastomeric material. In this embodiment, the fibers 891-89F generally extend transversally to the longitudinal direction of the track 21. This can provide transversal rigidity to the track 21.

[0212] In this embodiment, at least part of (i) the carcass 35, (ii) a traction projection 58_x, and (iii) a drive/guide lug 34_x of the track 21 are made of the fiber-reinforced elastomeric material. More particularly, in this embodiment, at least a majority of (i) the carcass 35, (ii) a traction projection 58_x, and (iii) a drive/guide lug 34_x of the track 21 are made of the fiber-reinforced elastomeric material. In the example shown in FIG. 44, the track 21 is entirely made of the fiber-reinforced elastomeric material except for any reinforcement, such as the transversal stiffening rods 36₁-36_N, the reinforcing cables 37₁-37_M, or the reinforcing fabric 43, which may be embedded in the fiber-reinforced elastomeric material.

[0213] The elastomeric matrix 87 may include any suitable elastomer. In some cases, the elastomeric matrix 87 may include a single elastomer (e.g., rubber). In other cases, the elastomeric matrix 87 may include two or more constituent elastomers (e.g., two or more different rubber compounds, one or more rubber compounds along with one or more other types of elastomer, etc.).

[0214] In this embodiment, each of the fibers 891-89F is a “short” fiber. For example, in some embodiments, each of the fibers 891-89F may have a length of no more than 10% of the width of the track 21, in some cases no more than 5% of the width of the track 21, in some cases no more than 3% of the width of the track 21, and in some cases even less (e.g., no more than 2% of the width of the track 21). For instance, in some embodiments, the length of each of the fibers 891-89F may be no more than 30 mm, in some cases no more than 20 mm, in some cases no more than 10 mm, and in some cases even less (e.g., no more than 5 mm). In this example of implementation, the fibers 891-89F are “chopped” or otherwise cut fibers.

[0215] In other embodiments, each of the fibers 891-89F may be a “long” fiber that extends along at least a majority of the width of the track 21. For instance, in some cases, each of the fibers 891-89F may extend along all of the width of the track.

[0216] The fibers 891-89F may be made of any suitable material. In this embodiment, the fibers 891-89F are polymeric fibers. More specifically, in this example, the fibers 891-89F are aramid fibers (e.g., Kevlar fibers). Various other

types of polymeric fibers may be used in other examples (e.g., polyvinyl alcohol (PVA) fibers). Also, in other embodiments, the fibers 891-89F may be any other suitable type of fibers (e.g., metallic fibers, carbon fibers, glass fibers, etc.).

[0217] In some embodiments, as it may provide transversal rigidity and/or other reinforcing effects, the fiber-reinforced elastomeric material of the track 21 may allow fewer or modified reinforcements to be embedded in it. For example, in this embodiment, the transversal stiffening rods 36₁-36_N have a high aspect ratio (e.g., are plate-like or “ruler” rods) and the track 21 is free of reinforcing fabric, as discussed previously.

[0218] The track 21 and its fiber-reinforced elastomeric material may be produced using various techniques. For example, in some embodiments, sheets of fiber-reinforced elastomeric material, which include respective portions of the elastomeric matrix 87 and respective ones of the fibers 891-89F, may be produced by calendaring, extrusion, pultrusion or any other process in which those fibers are incorporated into that portion of the elastomeric matrix 87. These sheets may then be placed into a mold for molding the track 21 such that the respective portions of the elastomeric matrix 87 and the respective ones of the fibers 891-89F of these sheets are combined into the track 21. Various other manufacturing processes may be used in other embodiments.

7.2 Slipper Elastomeric Material

[0219] In some embodiments, at least part of the elastomeric material of the track 21, including the elastomeric material 38 of the carcass 35, may include “slipper” rubber. The slipper rubber forms at least part of the inner surface 32 of the carcass 35 on which the slide rails 33₁, 33₂ slide. The slipper rubber exhibits a migration of lubricant (e.g., oil) contained within itself to the inner surface 32 of the carcass 35 in use. This helps to reduce friction between the slide rails 33₁, 33₂ and the track 21. As a result, this reduced friction may allow a reduction in number of the slide clips on the track 21 or the track 21 to be free of slide clips altogether. By reducing or eliminating contact between the slide rails 33₁, 33₂ and slide clips, noise generation is reduced. Any suitable type of slipper rubber which exhibits oil migration to its surface may be used.

7.3 Cellular Elastomeric Material

[0220] In some embodiments, at least part of the elastomeric material of the track 21, such as the elastomeric material 38 of the carcass 35, may include cellular elastomeric material (e.g., cellular rubber) at a widthwise position of an idler wheel path 50_i. The cellular elastomeric material is elastomeric material which contains cells (e.g., bubbles) created by introducing a gas (e.g., air) or a gas-producing agent (e.g., sodium bicarbonate) during manufacturing of the cellular elastomeric material. The cells of the cellular elastomeric material may include closed cells and/or open cells. The cellular elastomeric material creates a deformable shock-absorbing zone in the idler wheel path 50_i, such that, when idler wheels roll over the cellular elastomeric material, the cellular elastomeric material can deform more than if it was non-cellular (i.e., the same elastomeric compound but without cells) to absorb the shock and thus reduce noise generation. Any suitable type of cellular elastomeric material which provides shock-absorption may be used. This is

an example of an embodiment in which a shock absorbency (i.e., a capacity to absorb shocks) of the track **21** at the widthwise position of the idler wheel path **50_i** is greater than a shock absorbency of the track **21** at a widthwise position outside the idler wheel path **50_i**.

8. Track-Engaging Assembly

[0221] In some embodiments, the track-engaging assembly **24**, including the wheels **22**, **26₁-26₄**, **28₁-28₆**, **30₁**, **30₂** and the slide rails **33₁**, **33₂**, may be configured to reduce noise generation and/or provide other benefits (e.g., enhanced load distribution). Examples of how this may be achieved are discussed below.

8.1 Suspension Providing Increased Support

[0222] In some embodiments, the suspension unit **16** of the track-engaging assembly **24** may provide increased support. This can be achieved in various ways.

8.1.1 Additional Idler Wheels

[0223] In some embodiments, as shown in FIG. **40**, a number of idler wheels of the track-engaging assembly **24** that engage the bottom run of the endless track **21** may be increased. For instance, in some embodiments, the track-engaging assembly **24** may comprise a set of idler wheels spaced apart in the longitudinal direction of the track system **14** and substantially aligned with one another to roll on a given idler wheel path **50_i** on the bottom run of the track **21** such that a longitudinal spacing V_w of any two successive idler wheels of the set of idler wheels on the idler wheel path **50_i** is less than half of the length of the track system **14**, in some cases no more than 40% of the length of the track system **14**, in some cases no more than 30% of the length of the track system **14**, in some cases no more than 20% of the length of the track system **14**, and in some cases even less (e.g., no more than 10% of the length of the track system **14**).

[0224] For example, in this embodiment, the track-engaging assembly **24** comprises at least four idler wheels spaced apart in the longitudinal direction of the track **21** and substantially aligned with one another so as to roll on a given idler wheel path **50_i** on the bottom run of the track **21**. In this case, there are six idler wheels rolling on the given idler wheel path **50_i**. In other cases, there may be four, five, or more than six idler wheels rolling on the given idler wheel path **50_i**.

[0225] More particularly, in this embodiment, the track-engaging assembly **24** comprises a set of six idler wheels **26₁**, **28_{A1}-28_{A5}** rolling on the leftmost idler wheel path **50₁** and a set of six idler wheels **26₄**, **28_{A6}-28_{A10}** rolling on the rightmost idler wheel path **50₄**. Also, in this embodiment, the track-engaging assembly **24** comprises idler wheels **26₂**, **26₃**, **28_{B1}-28_{B4}** which are located between the idler wheels **26₁**, **28_{A1}-28_{A5}** and the idler wheels **26₄**, **28_{A6}-28_{A10}** in the widthwise direction of the track **21** and roll on the idler wheel paths **50₂**, **50₃**. Various other wheel configurations are possible in other embodiments.

[0226] In this example of implementation, the idler wheels **26₁-26₄**, **28_{A1}-28_{A12}**, **28_{B1}-28_{B4}** are mounted to elongated wheel-supporting members **33_{A1}**, **33_{A2}** of the track-engaging assembly **24**. In this case, the elongated wheel-supporting members **33_{A1}**, **33_{A2}** are not designed primarily to slide on the track **21** like the slide rails **33₁**, **33₂** discussed above but are rather designed primarily for supporting the idler wheels

26₁-26₄, **28_{A1}-28_{A12}**, **28_{B1}-28_{B2}**. In other cases, the elongated wheel-supporting members **33_{A1}**, **33_{A2}** may slide on the track **21** like the slide rails **33₁**, **33₂** discussed above and thus may also constitute slide rails.

8.1.2 Additional Slide Rails

[0227] In some embodiments, as shown in FIG. **41**, a number of slide rails of the track-engaging assembly **24** that slide along the bottom run of the endless track **21** may be increased. For instance, in some embodiments, the track-engaging assembly **24** may comprise a plurality of side rails spaced apart in the widthwise direction of the track system **14** such that a widthwise spacing V_r of any two adjacent slide rails is less than half of the width of the track system **14**, in some cases no more than 40% of the width of the track system **14**, in some cases no more than 30% of the width of the track system **14**, in some cases no more than 20% of the width of the track system **14**, and in some cases even less (e.g., no more than 10% of the width of the track system **14**).

[0228] For example, in this embodiment, the track-engaging assembly **24** comprises at least three slide rails spaced apart in the widthwise direction of the track **21**. In this case, there are four slide rails. In other cases, there may be three, five, or more than five slide rails.

[0229] More particularly, in this embodiment, the track-engaging assembly **24** comprises four slide rails **33_{A1}-33_{A4}** which are evenly distributed in the widthwise direction of the track **21**. In this case, the slide rails **33_{A1}-33_{A4}** are substantially identical in size and shape. Also, in this case, the idler wheels **26₁-26₄**, **28₁-28₆** are mounted to respective ones of the slide rails **33_{A1}-33_{A4}**. Various other slide rail configurations are possible in other embodiments (e.g., the slide rails **33_{A1}-33_{A4}** may not be evenly distributed in the widthwise direction of the track **21**; two or more of the slide rails **33_{A1}-33_{A4}** may differ in size and/or shape; one or more of the slide rails **33_{A1}-33_{A4}** may not have any idler wheel mounted thereto).

8.2 Extremely Low-Friction Slide Rails

[0230] In some embodiments, the slide rails **33₁**, **33₂** may include very low friction material to minimize as much as possible their friction with the endless track **21**.

[0231] In some cases, the slide rails **33₁**, **33₂** may have a friction of coefficient with the endless track **21** that is low enough to allow the track **21** to be free of slide members (i.e., “clips”) such as the slide members discussed previously without detrimentally affecting performance of the track system **14**.

8.3 Track Tensioner

[0232] In some embodiments, as shown in FIG. **42**, the track-engaging assembly **24** may comprise a track tensioner **72** for maintaining tension of the endless track **21**. This may counter a tendency of the track **21** to stretch due to centrifugal forces when it is driven at high speeds. In this embodiment, the track tensioner **72** is connected between a structural support **74** of the track-engaging assembly **24** and the rear idler wheels **26₁-26₄** to urge the rear idler wheels **26₁-26₄** in a direction to maintain the tension of the track **21**.

[0233] The track tensioner **72** comprises a resilient device **73** configured to change from a first configuration to a second configuration in response to a load and return to the first configuration in response to removal of the load. More

particularly, in this embodiment, the track tensioner **72** is a fluidic tensioning system, e.g., a hydraulic or pneumatic tensioning system, and the resilient device **73** is a piston-cylinder actuator connected to a fluid reservoir (not shown). In this example of implementation, the actuator **73** is a hydraulic piston-cylinder actuator.

[0234] In this embodiment, the piston-cylinder actuator **73** is connected to the structural support **74** and to an idler wheel carrier **75** which carries an axle of the rear idler wheels **26₁-26₄**, and which can move in slots **76₁, 76₂** defined by the slide rails **33₁, 33₂**. The tensioning actuator **73** can apply the tension in the track **21** by extending or retracting to move the idler wheel carrier **75** in the slots **76₁, 76₂** and thus move rear idler wheels **26₁-26₄** further or closer to the drive wheels **22**.

[0235] The track tensioner **72** may be configured in various other ways in other embodiments.

[0236] For example, in some embodiments, the resilient device **73** may comprise a spring such as a coil spring (e.g., a metallic or polymeric coil spring), an elastomeric spring or a leaf spring, or any other device that changes in configuration under load and recovers its initial configuration when the load is removed.

[0237] As another example, in other embodiments, the track tensioner **72** may be located elsewhere and/or act on a different part of the track **21**. For instance, FIG. **43** shows an embodiment in which the track tensioner **72** comprises a first resilient device **911** contacting a first segment **921** of the top run **65** of the track **21** which extends between the rear idler wheels **26₁-26₄**, and the upper roller wheels **30₁, 30₂** and a second resilient device **912** contacting a second segment **922** of the top run **65** of the track **21** which extends between the upper roller wheels **30₁, 30₂** and the drive wheels **22**. In this embodiment, each resilient device **91_i** comprises a roller wheel **95** and a spring **93** that is connected between the roller wheel **95** and a structural support **94** of the track-engaging assembly **24** in order to urge the roller wheel **95** against the track **21** to tension the track **21**. This can help to counter a tendency of the segments **921, 922** of the top run **65** of the track **21** to deform since they would otherwise be unsupported.

[0238] Instead of or in addition to using a track tensioner **72**, in some embodiments, the endless track **21** may comprise a substantially inextensible material that can substantially prevent the track **21** from stretching in a range of speeds at which it is expected to be driven. For example, in some embodiments, the reinforcing cables **37₁-37_M** of the track **21** may comprise Kevlar™ cables.

[0239] Although embodiments described above have been presented individually, any feature of any embodiment described above may be used in combination with any feature of any other embodiment described above.

[0240] While embodiments described above relate to a snowmobile, in other embodiments, any feature of any embodiment described above may be used in another type of off-road vehicle.

[0241] For example, in some embodiments, as shown in FIGS. **45A** and **45B**, any feature of any embodiment described above may be used in an all-terrain vehicle (ATV) **110** comprising a set of track systems **1141-1144** providing traction to the ATV on the ground. The ATV **10** comprises a prime mover **112** in a driving relationship with the track systems **1141-1144** via the ATV's powertrain, a seat **118**, and a user interface **120**, which enable a user of the ATV **110** to

ride the ATV **110** on the ground. In this case, the seat **118** is a straddle seat and the ATV **110** is usable by a single person such that the seat **118** accommodates only that person driving the ATV **110**. In other cases, the seat **118** may be another type of seat, and/or the ATV **110** may be usable by two individuals, namely one person driving the ATV **110** and a passenger, such that the seat **118** may accommodate both of these individuals (e.g., behind one another or side-by-side) or the ATV **110** may comprise an additional seat for the passenger. For example, in other embodiments, the ATV **110** may be a side-by-side ATV, sometimes referred to as a "utility terrain vehicle" or "UTV". The user interface **120** comprises a steering device operated by the user to control motion of the ATV **110** on the ground. In this case, the steering device comprises handlebars. In other cases, the steering device may comprise a steering wheel or other type of steering element. Each of the front track systems **1141, 1142** is pivotable about a steering axis of the ATV **110** in response to input of the user at the handlebars in order to steer the ATV **110** on the ground.

[0242] In this embodiment, with additional reference to FIGS. **46A** and **46B**, each track system **1141-1144** is mounted in place of a ground-engaging wheel **1131-1134** that may otherwise be mounted to the ATV **110** to propel the ATV **110** on the ground. That is, the ATV **110** may be propelled on the ground by four ground-engaging wheels **1131-1134** with tires instead of the track systems **1141-1144**. Basically, in this embodiment, the track systems **1141-1144** may be used to convert the ATV **110** from a wheeled vehicle into a tracked vehicle, thereby enhancing its traction and floatation on the ground.

[0243] Any feature described herein with respect to the track system **14** of the snowmobile **10** may be applied to a track system **1141-1144** of the ATV **110**.

[0244] The snowmobile **10** and the ATV **110** considered above are examples of tracked recreational vehicles. While they can be used for recreational purposes, such tracked recreational vehicles may also be used for utility purposes in some cases.

[0245] Certain additional elements that may be needed for operation of certain embodiments have not been described or illustrated as they are assumed to be within the purview of those of ordinary skill in the art. Moreover, certain embodiments may be free of, may lack and/or may function without any element that is not specifically disclosed herein.

[0246] Although various embodiments and examples have been presented, this was for the purpose of describing, but not limiting, the invention. Various modifications and enhancements will become apparent to those of ordinary skill in the art and are within the scope of the invention.

1-20. (canceled)

21. A track for traction of a vehicle, the track being mountable around a track-engaging assembly that comprises a drive wheel for driving the track and an idler wheel for contacting the track, the track comprising elastomeric material to be flexible around the track-engaging assembly, the track comprising:

- an inner surface for facing the track-engaging assembly, the inner surface comprising an idler wheel path for the idler wheel;
- a ground-engaging outer surface for engaging the ground;
- a plurality of traction projections projecting from the ground-engaging outer surface; and

a plurality of stiffening rods extending transversally to a longitudinal direction of the track, each stiffening rod having a dimension in a thickness direction of the track that is less where the stiffening rod overlaps the idler wheel path in a widthwise direction of the track than where the stiffening rod does not overlap the idler wheel path in the widthwise direction of the track.

22. The track of claim **21**, wherein the idler wheel is a roller wheel and the idler wheel path is a rolling path for the roller wheel to roll on a bottom run of the track.

23. The track of claim **21**, wherein the idler wheel is a first idler wheel, the idler wheel path is a first idler wheel path, the track-engaging assembly comprises a second idler wheel spaced from the first idler wheel in a widthwise direction of the track-engaging assembly, the inner surface comprises a second idler wheel path for the second idler wheel, the second idler wheel path is spaced from the first idler wheel in the widthwise direction of the track, and the dimension of the stiffening rod in the thickness direction of the track is less where the stiffening rod overlaps the second idler wheel path in the widthwise direction of the track than where the stiffening rod does not overlap the second idler wheel path in the widthwise direction of the track.

24. The track of claim **21**, wherein a ratio of (i) a difference between the dimension of the stiffening rod in the thickness direction of the track where the stiffening rod does not overlap the idler wheel path in the widthwise direction of the track and the dimension of the stiffening rod in the thickness direction of the track where the stiffening rod overlaps the idler wheel path in the widthwise direction of the track over (ii) the dimension of the stiffening rod in the thickness direction of the track where the stiffening rod does not overlap the idler wheel path in the widthwise direction of the track is at least 0.1, at least 0.15, or at least 0.2.

25. The track of claim **21**, wherein a difference between the dimension of the stiffening rod in the thickness direction of the track where the stiffening rod does not overlap the idler wheel path in the widthwise direction of the track and the dimension of the stiffening rod in the thickness direction of the track where the stiffening rod overlaps the idler wheel path in the widthwise direction of the track is at least 0.03 inches, at least 0.045 inches, or at least 0.06 inches.

26. The track of claim **21**, wherein the stiffening rod comprises a surface facing the inner surface and receding towards the ground-engaging outer surface where the stiffening rod overlaps the idler wheel path in the widthwise direction of the track.

27. The track of claim **23**, wherein the stiffening rod comprises a surface facing the inner surface and receding towards the ground-engaging outer surface where the stiffening rod overlaps the first idler wheel path in the widthwise direction of the track and where the stiffening rod overlaps the second idler wheel path in the widthwise direction of the track.

28. The track of claim **21**, wherein the stiffening rod comprises a recess overlapping the idler wheel path in the widthwise direction of the track.

29. The track of claim **28**, wherein a depth of the recess is at least 0.03 inches, at least 0.045 inches, or at least 0.06 inches.

30. The track of claim **28**, wherein a ratio of a depth of the recess over the dimension of the stiffening rod in the thickness direction of the track where the stiffening rod does not overlap the idler wheel path in the widthwise direction of the track is at least 0.1, at least 0.15, or at least 0.2.

31. The track of claim **21**, wherein a longitudinal end portion of the stiffening rod overlaps the idler wheel path in the widthwise direction of the track.

32. The track of claim **23**, wherein a first longitudinal end portion of the stiffening rod overlaps the first idler wheel path in the widthwise direction of the track and a second longitudinal end portion of the stiffening rod overlaps the second idler wheel path in the widthwise direction of the track.

33. The track of claim **21**, comprising a plurality of reinforcing cables extending generally in the longitudinal direction of the track.

34. The track of claim **33**, wherein the plurality of reinforcing cables are located between the stiffening rods and the inner surface in the thickness direction of the track.

35. The track of claim **33**, wherein the plurality of reinforcing cables are located between the stiffening rods and the ground-engaging outer surface in the thickness direction of the track.

36. The track of claim **21**, comprising a plurality of drive/guide projections projecting from the inner surface.

37. The track of claim **36**, wherein the plurality of drive/guide projections are configured for engaging the drive wheel to drive the track.

38. The track of claim **21**, wherein a thickness of the track from the inner surface to the ground-engaging outer surface is no more than 0.25 inches.

39. The track of claim **21**, wherein the vehicle is a snowmobile and the track is a snowmobile track.

40. A track for traction of a vehicle, the track being mountable around a track-engaging assembly that comprises a drive wheel for driving the track and an idler wheel for contacting the track, the track comprising elastomeric material to be flexible around the track-engaging assembly, the track comprising:

- an inner surface for facing the track-engaging assembly, the inner surface comprising an idler wheel path for the idler wheel;

- a ground-engaging outer surface for engaging the ground; and

- a plurality of traction projections projecting from the ground-engaging outer surface;

wherein a shock absorbency of the track is greater where the idler wheel path is located in a widthwise direction of the track than where the idler wheel path is not located in the widthwise direction of the track.

* * * * *