



(19) **United States**

(12) **Patent Application Publication**
Olason

(10) **Pub. No.: US 2025/0283531 A1**

(43) **Pub. Date: Sep. 11, 2025**

(54) **CONTINUOUSLY VARIABLE TRANSMISSION FOR RECREATIONAL VEHICLES AND RELATED COMPONENTS**

(71) Applicant: **Arctic Cat Inc.**, Thief river Falls, MN (US)

(72) Inventor: **Kyle Douglas Olason**, Thief river Falls, MN (US)

(21) Appl. No.: **19/218,951**

(22) Filed: **May 27, 2025**

Related U.S. Application Data

(63) Continuation of application No. 18/195,163, filed on May 9, 2023, now Pat. No. 12,338,886, which is a continuation of application No. 16/893,752, filed on Jun. 5, 2020, now Pat. No. 11,680,635.

(60) Provisional application No. 62/981,090, filed on Feb. 25, 2020.

Publication Classification

(51) **Int. Cl.**
F16H 55/56 (2006.01)
B62M 27/02 (2006.01)
F16H 63/06 (2006.01)

(52) **U.S. Cl.**
CPC **F16H 55/563** (2013.01); **F16H 63/067** (2013.01); **B62M 27/02** (2013.01)

(57) **ABSTRACT**

Embodiments of the present disclosure describe a drive pulley for a continuously variable transmission including a stationary sheave with a stationary shaft, a movable sheave axially movable relative to the stationary sheave and in contact with the stationary shaft; a spider in contact with at least the moveable sheave and stationary shaft; a spring member, biasing the movable sheave axially away from the stationary sheave; at least one centrifugal actuator including an arm pivotally connected to one of the movable sheave and the spider, the arm pivoting away from the one of the movable sheave and the spider as a speed of rotation of the drive pulley increases, the arm pushing against another one of the movable sheave and the spider as the arm pivots away from the one of the movable sheave and the spider, thereby moving the movable sheave axially toward the stationary sheave, the at least one centrifugal actuator being disposed radially outward of the stationary sheave shaft; and a torque transfer assembly operatively connected to at least one of the spider and the movable sheave, the torque transfer assembly transferring torque between the spider and the movable sheave, the torque transfer assembly including, a torque bearing assembly and at least one roller assembly, positioned on a helixed torque pin, the torque pin connected to the spider; wherein as the roller assembly wears, the at least one roller assembly tracks along a helixed path of the torque pin in a distal direction from the bearing assembly.

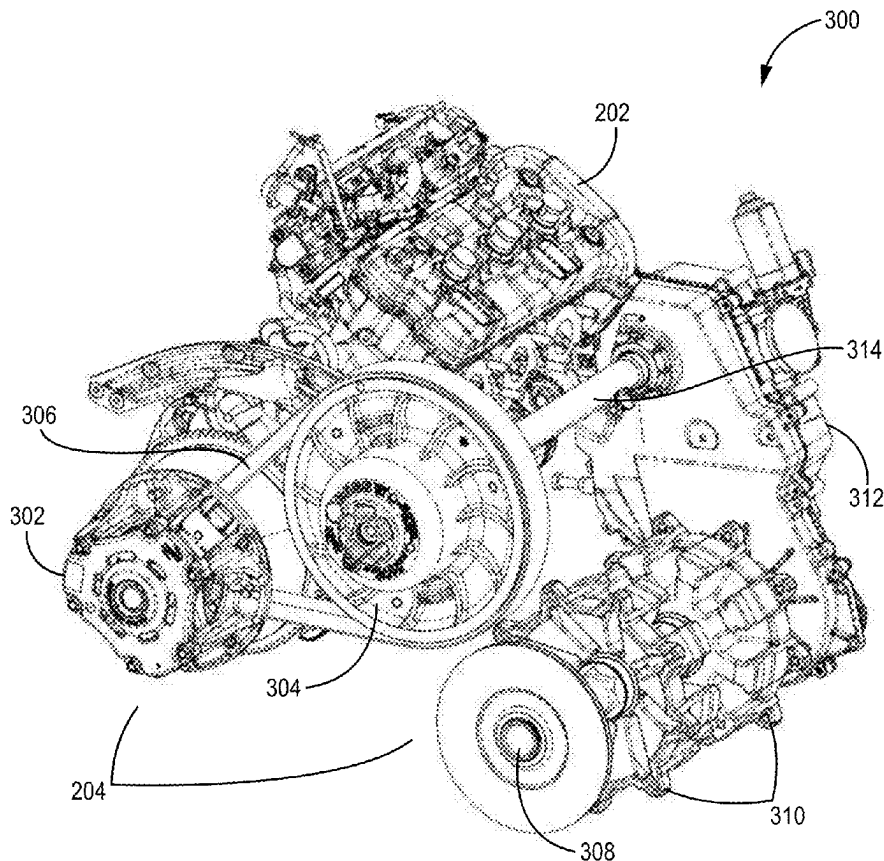

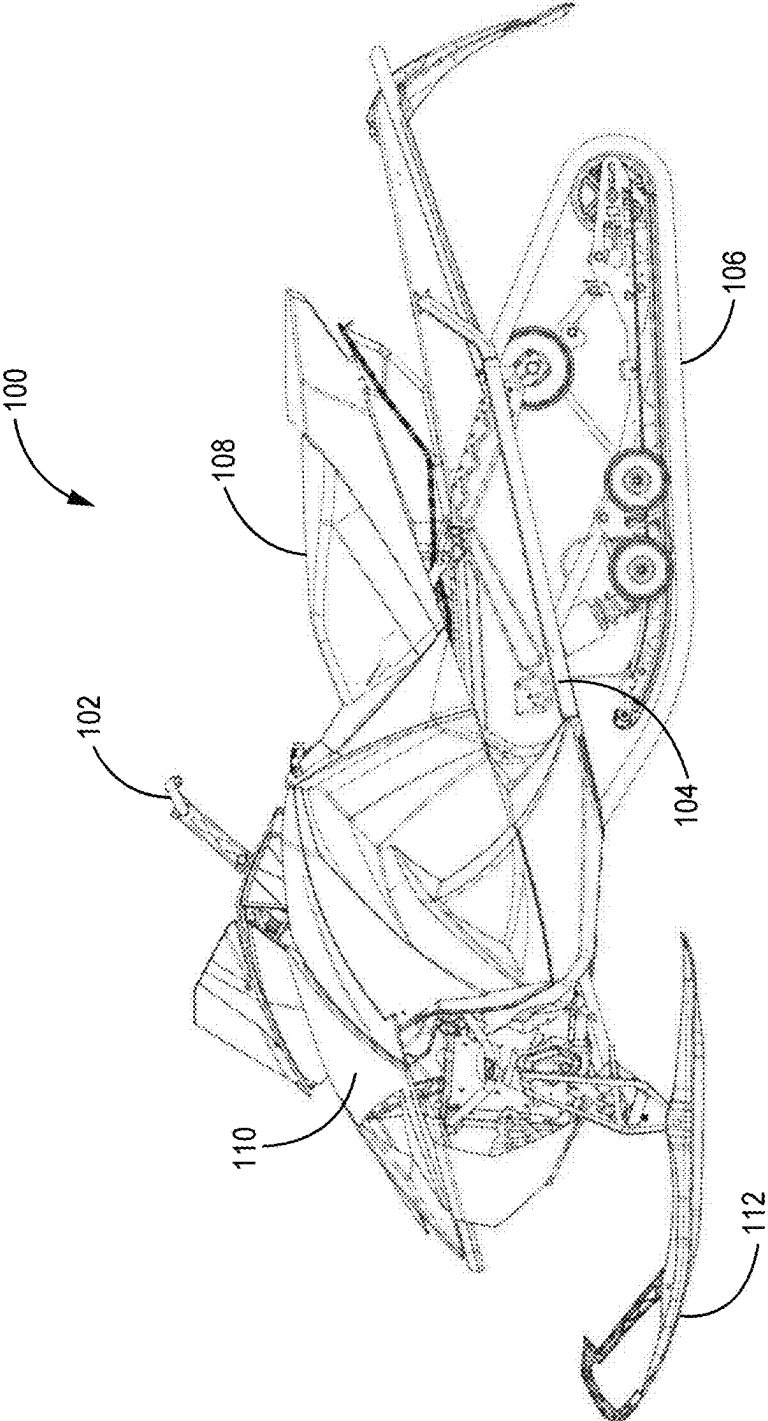

FIG. 1

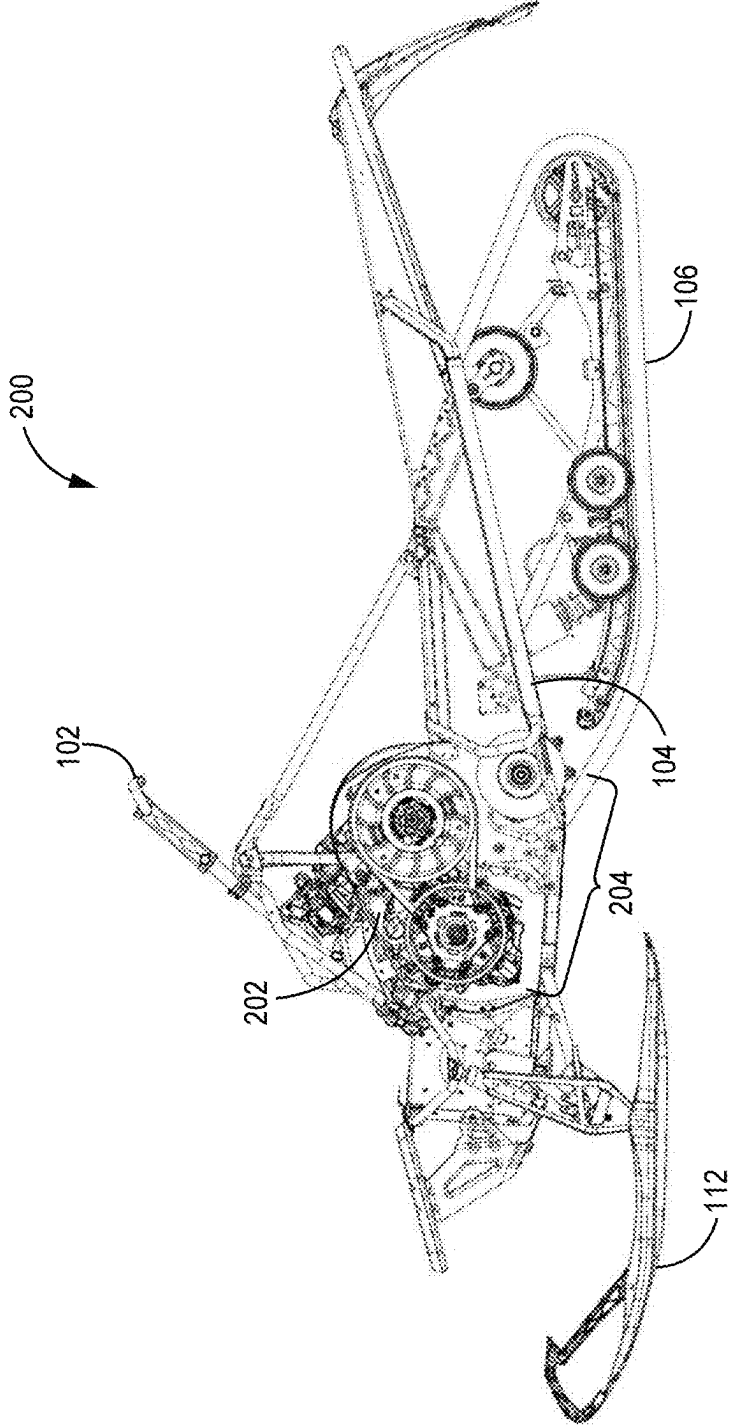

FIG. 2A

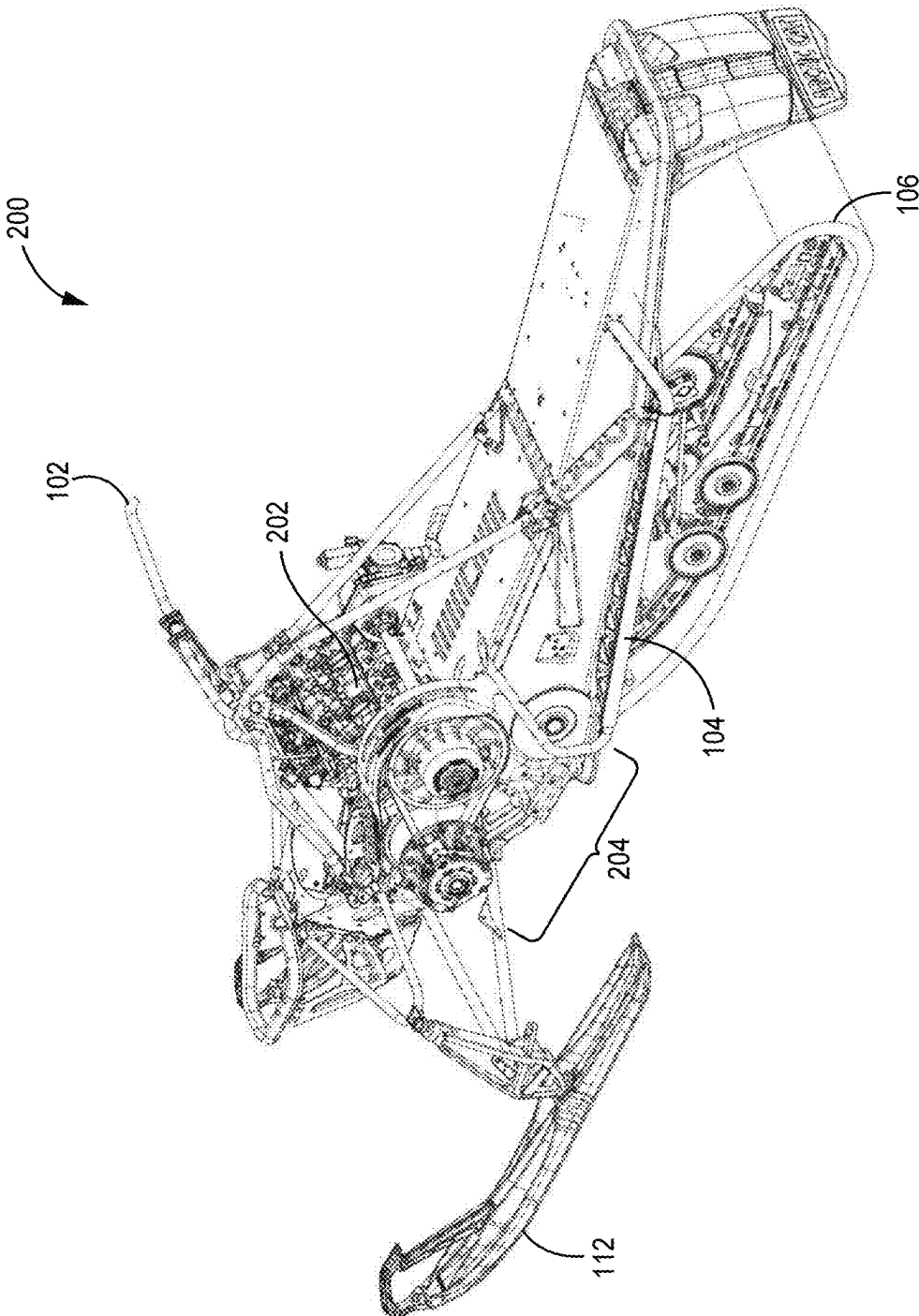

FIG. 2B

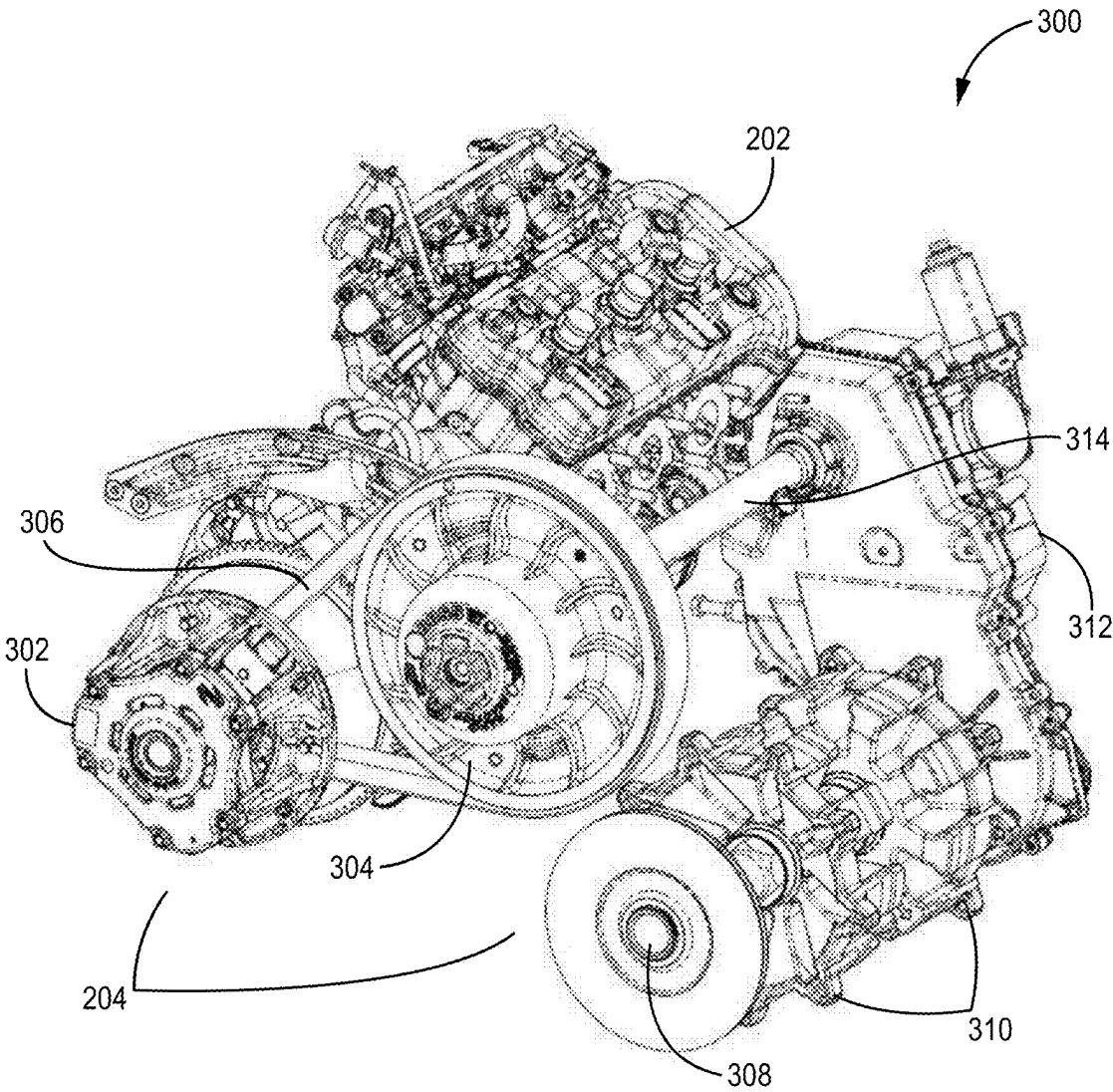

FIG. 3A

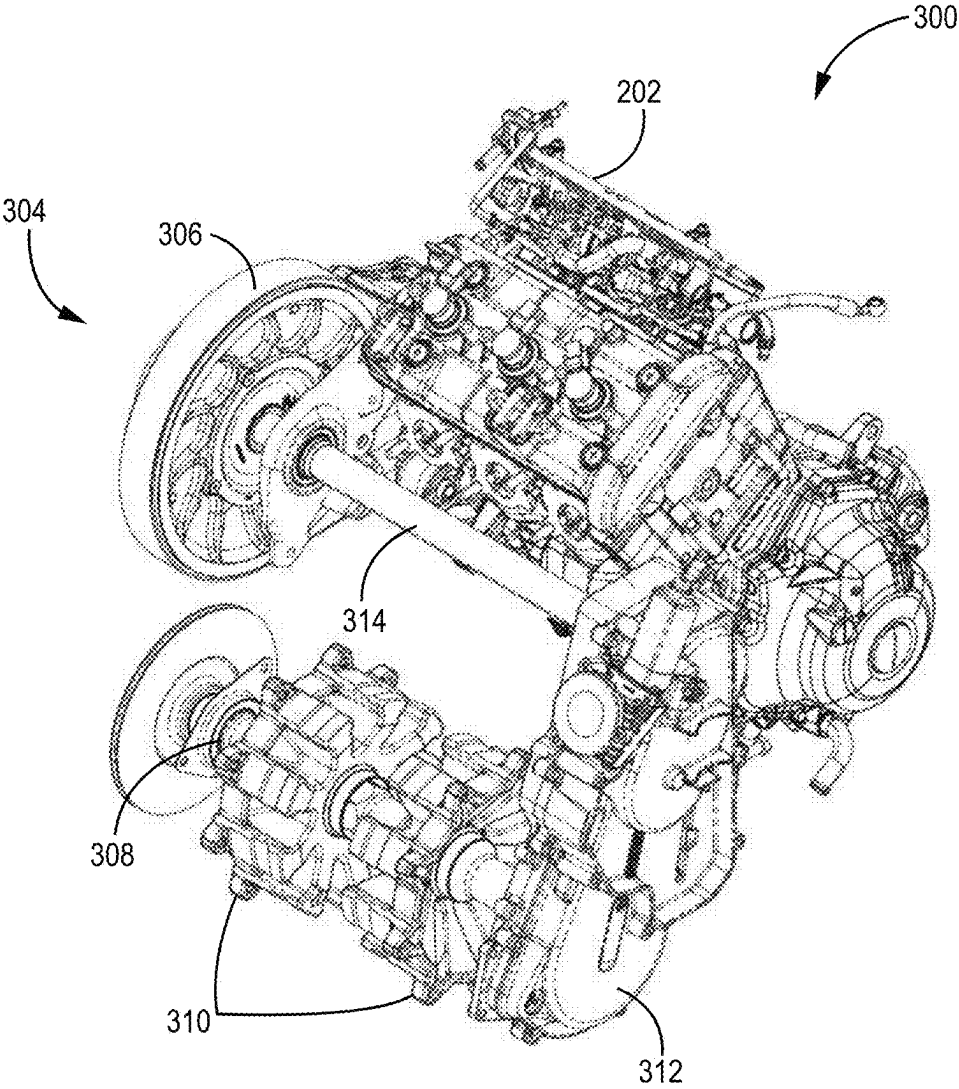

FIG. 3B

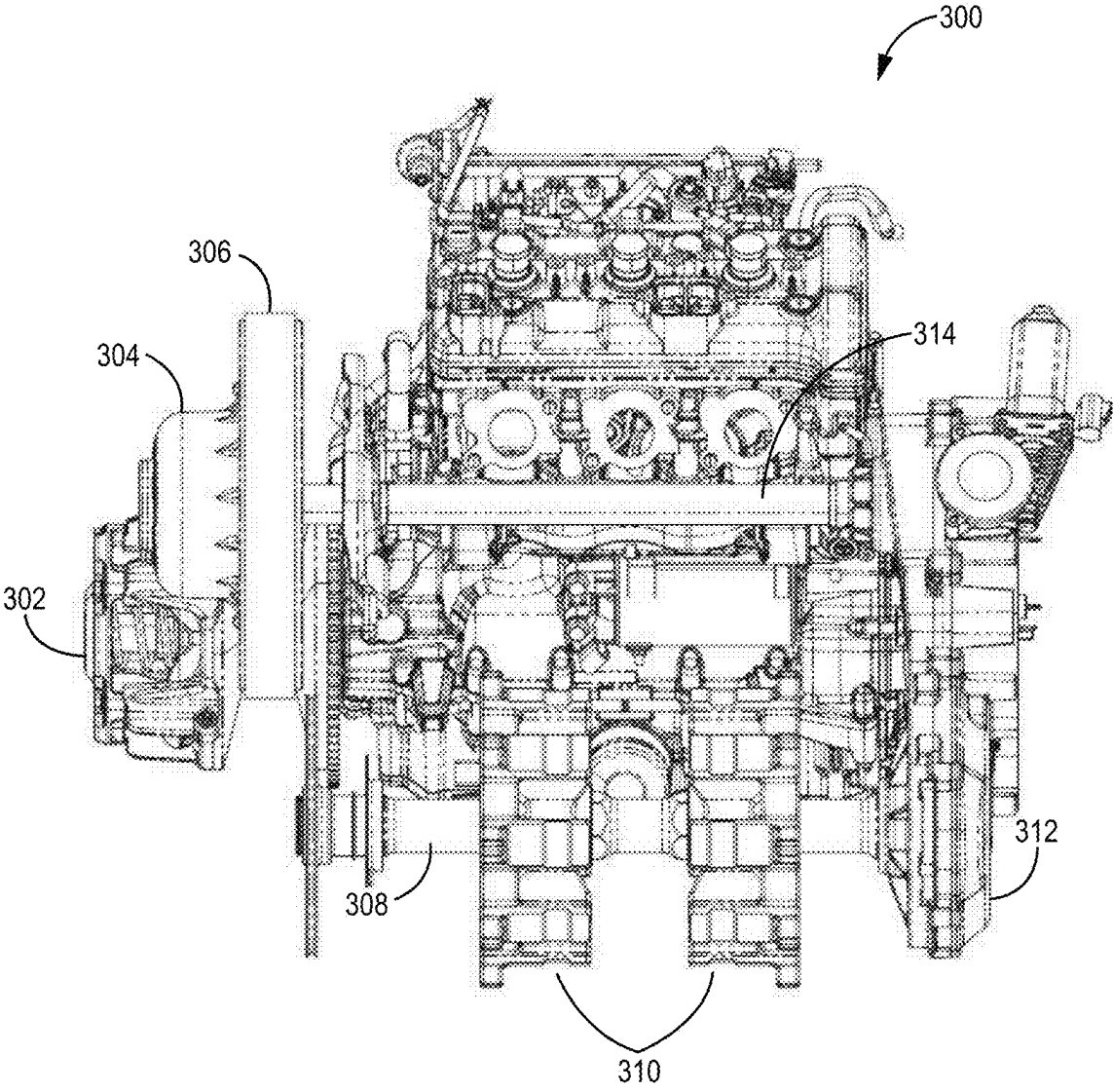

FIG. 3C

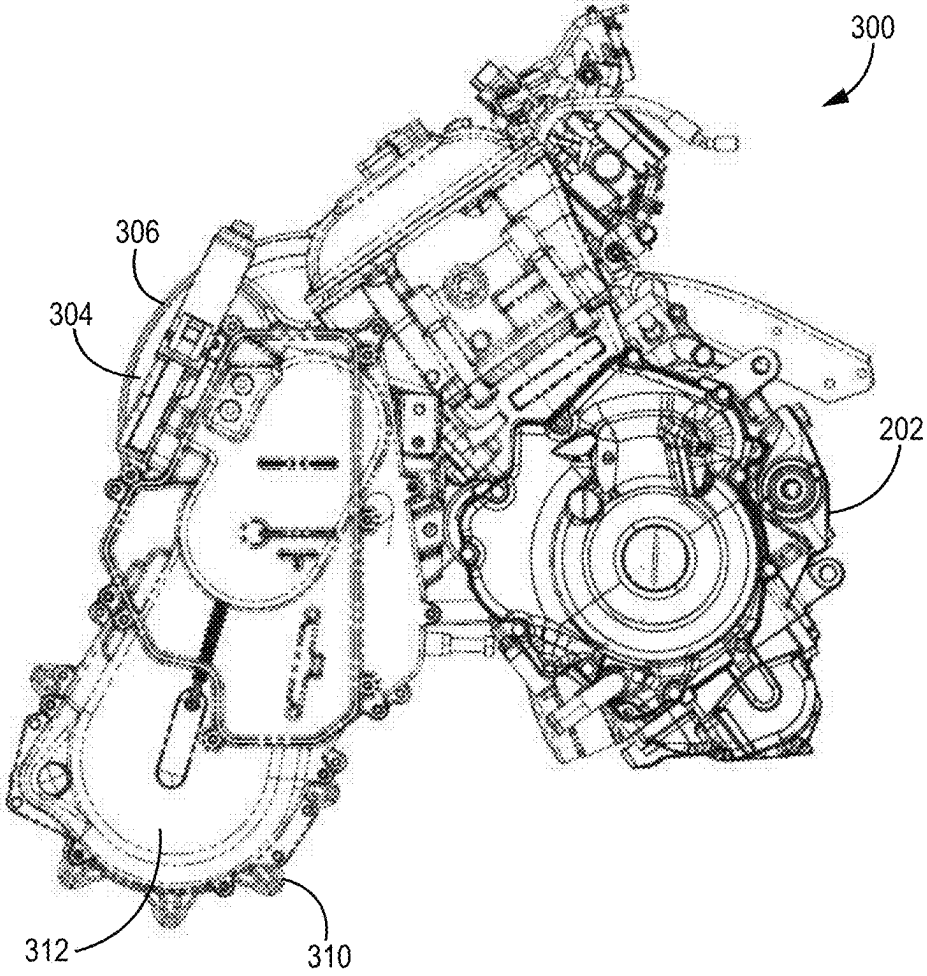

FIG. 3D

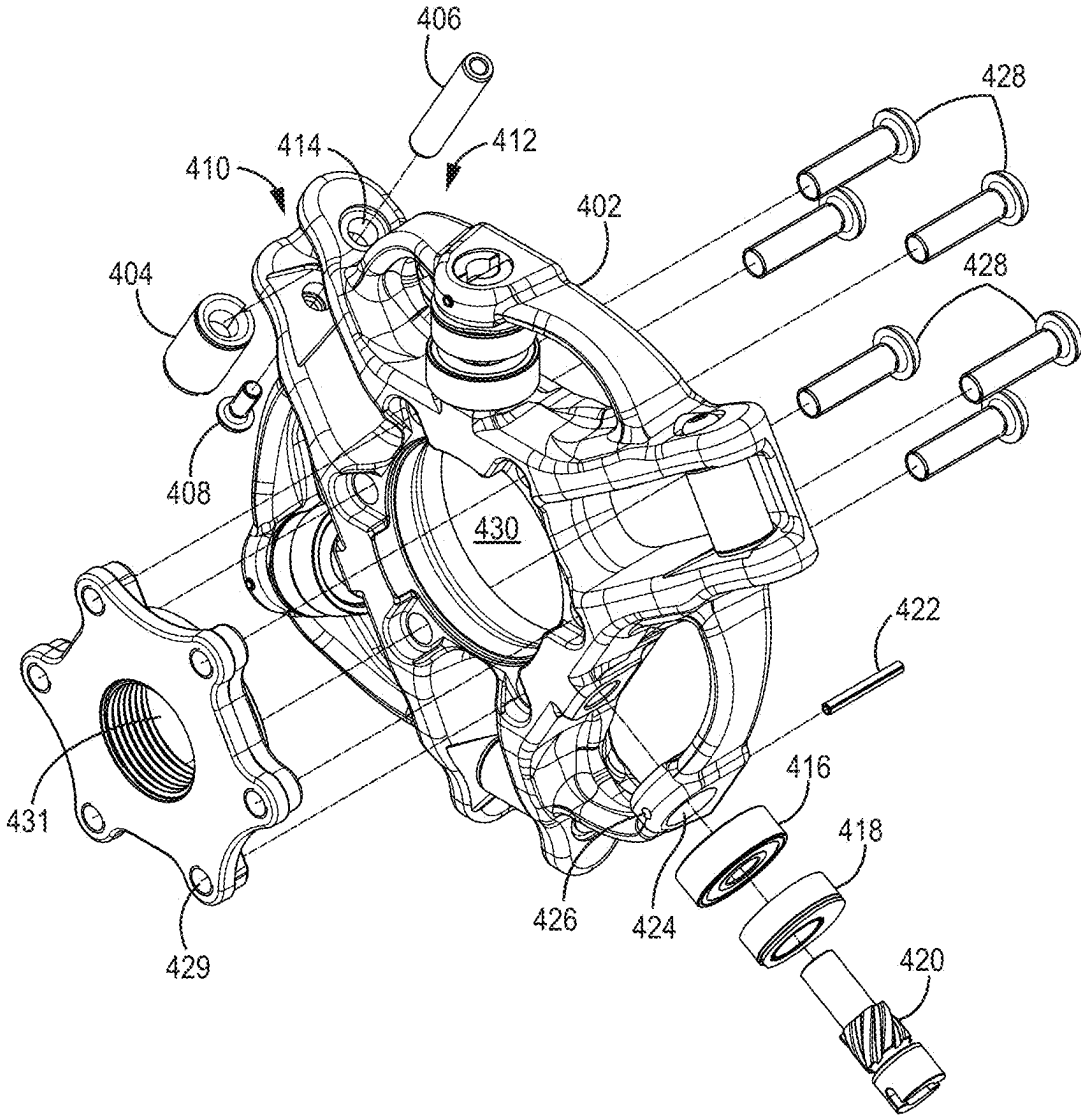
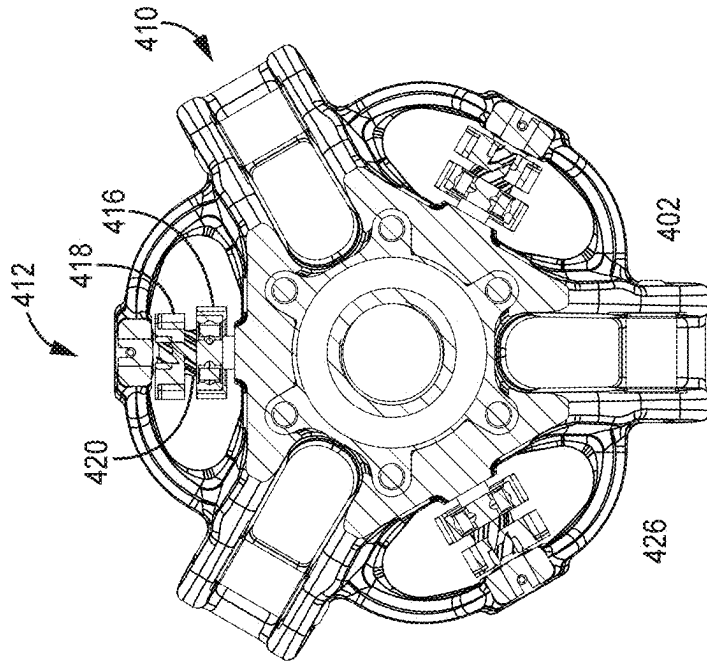
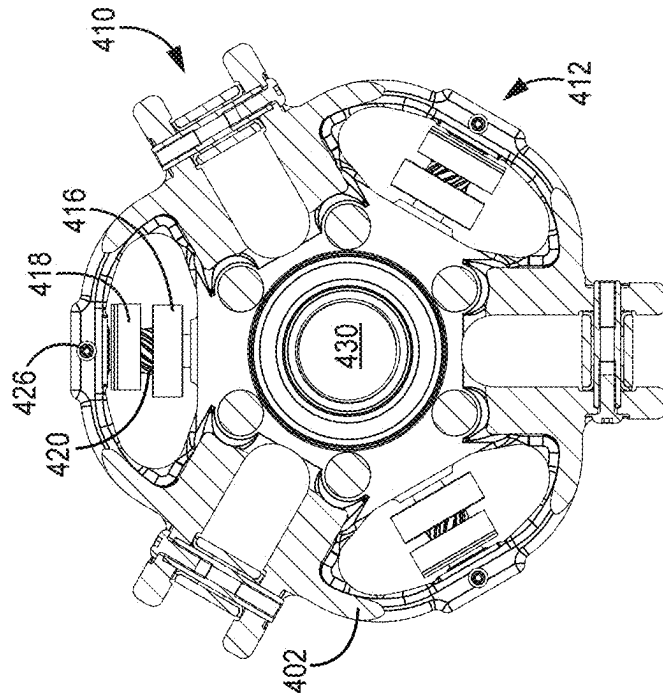

FIG. 4A



SECTION B-B

FIG. 4D



SECTION A-A

FIG. 4C

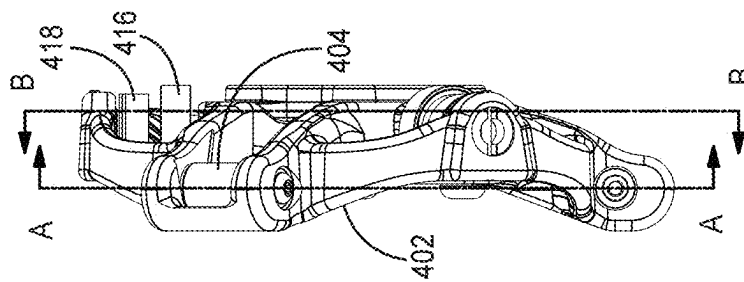

FIG. 4B

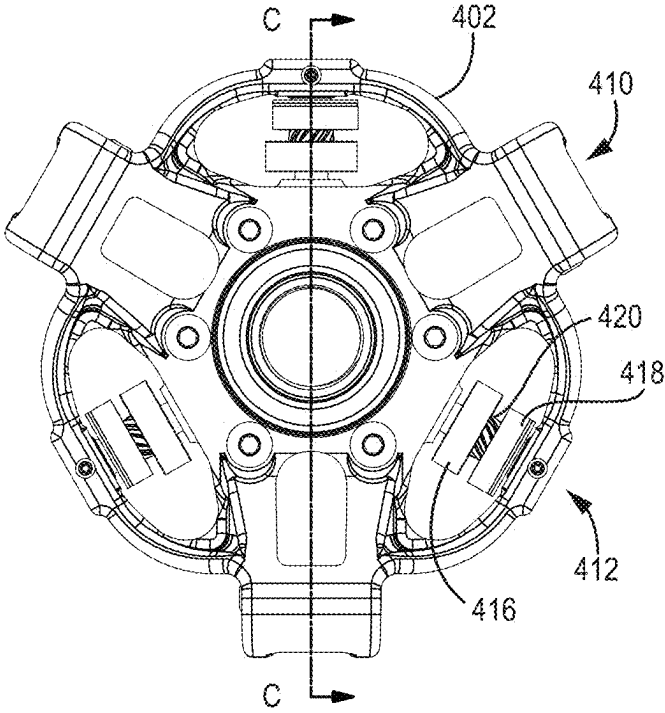
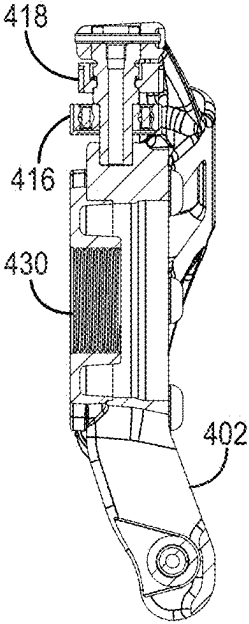

FIG. 4E



SECTION C-C

FIG. 4F

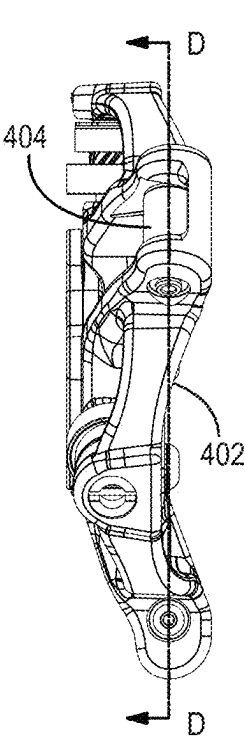

FIG. 4G

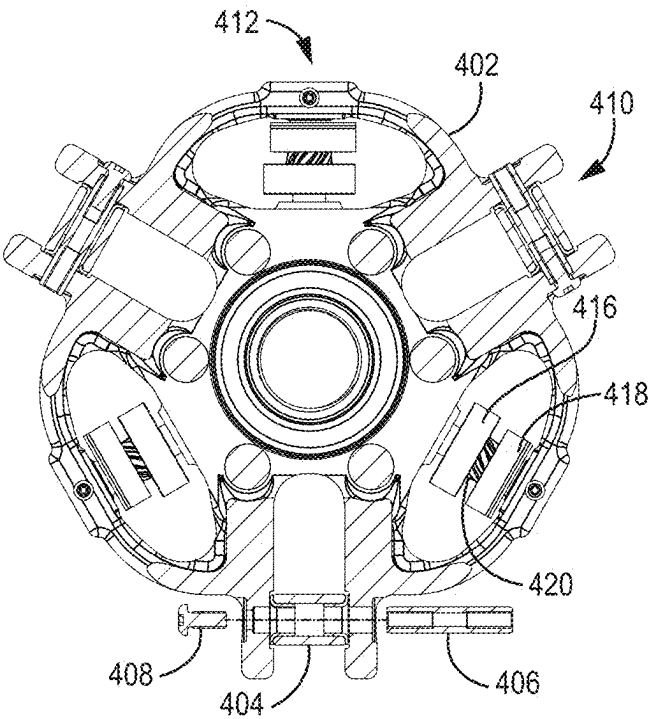

FIG. 4H

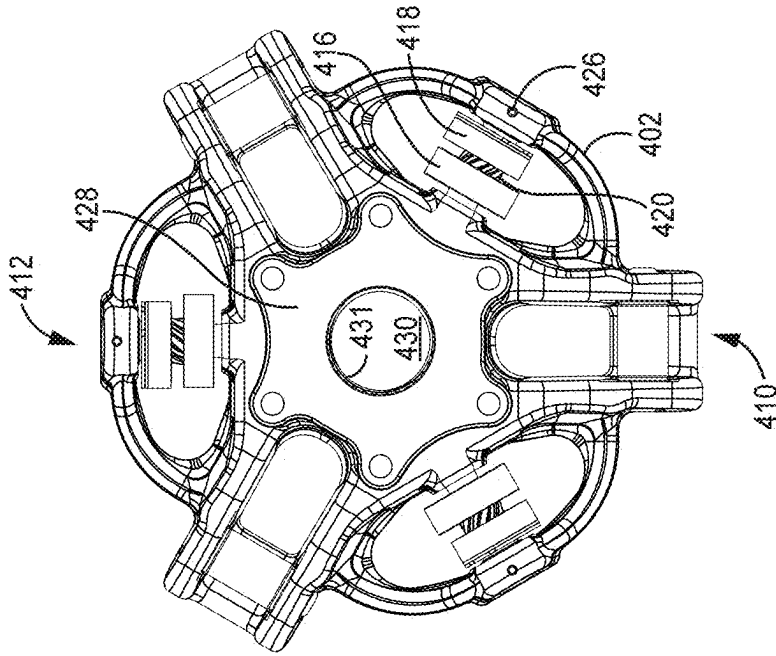

FIG. 4I

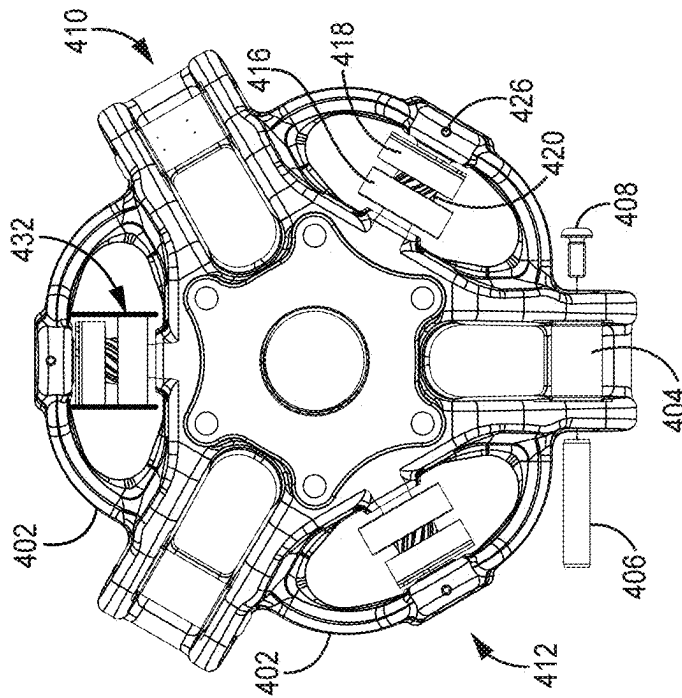

FIG. 4J

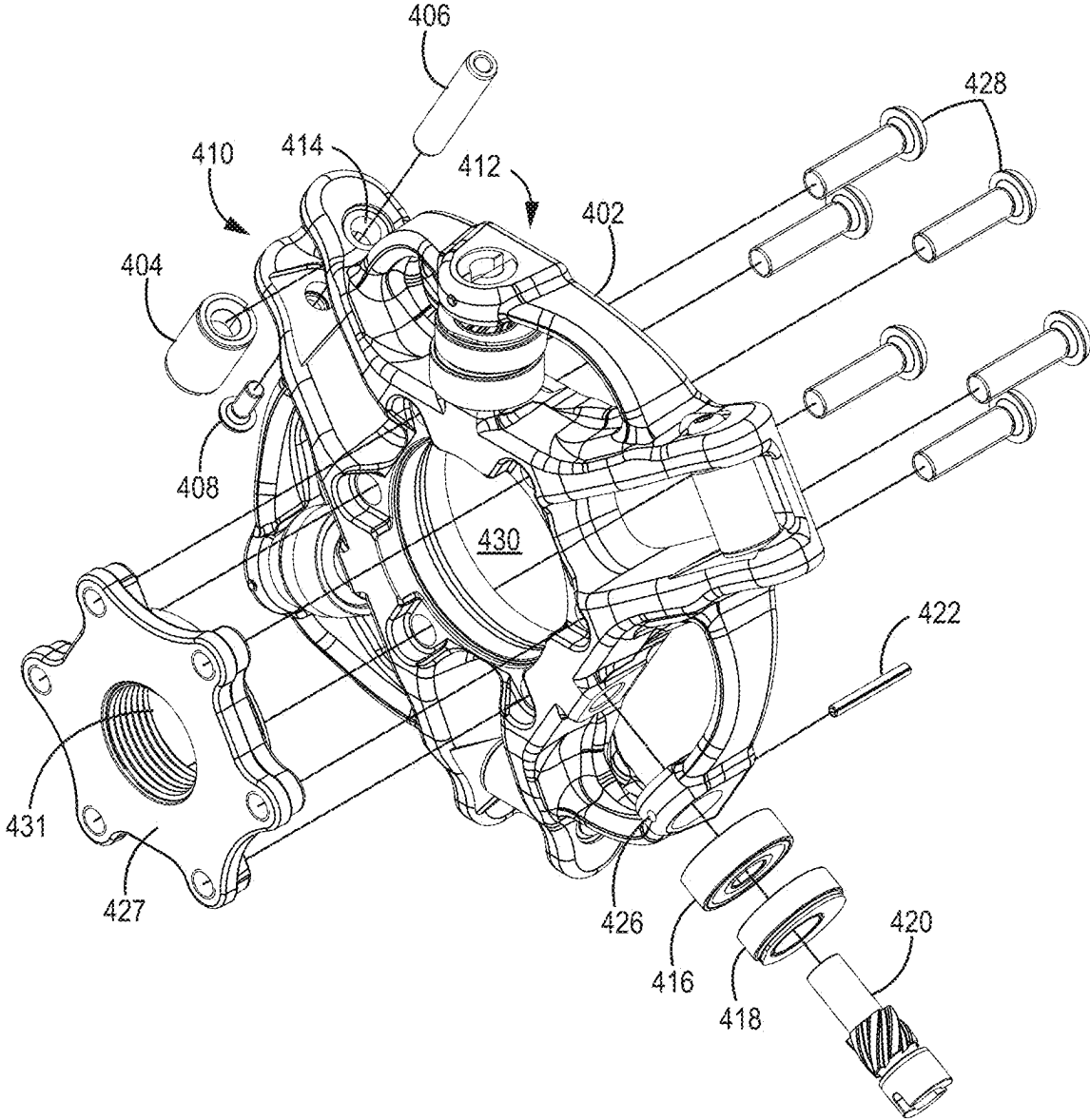

FIG. 5A

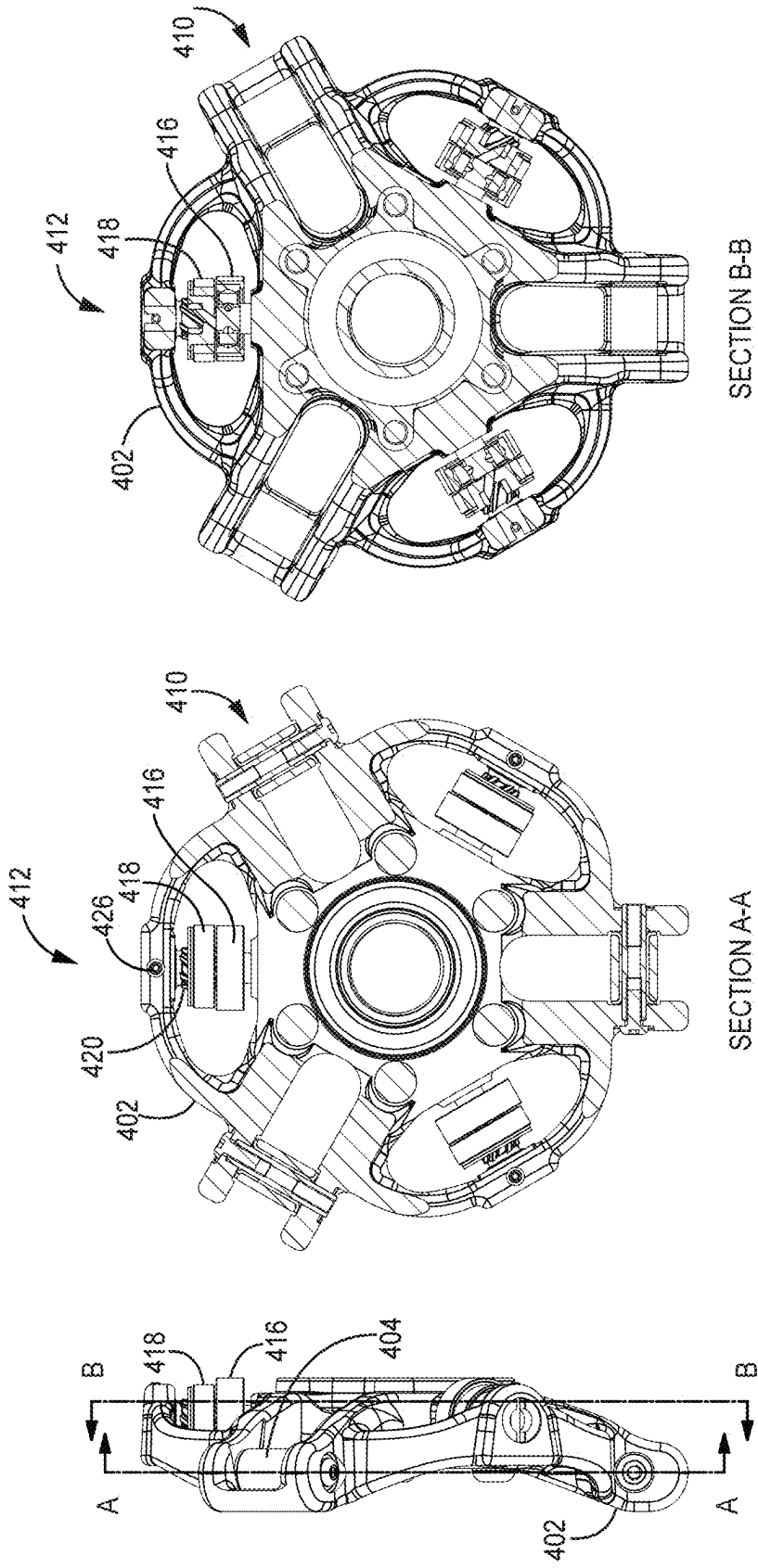

FIG. 5D

FIG. 5C

FIG. 5B

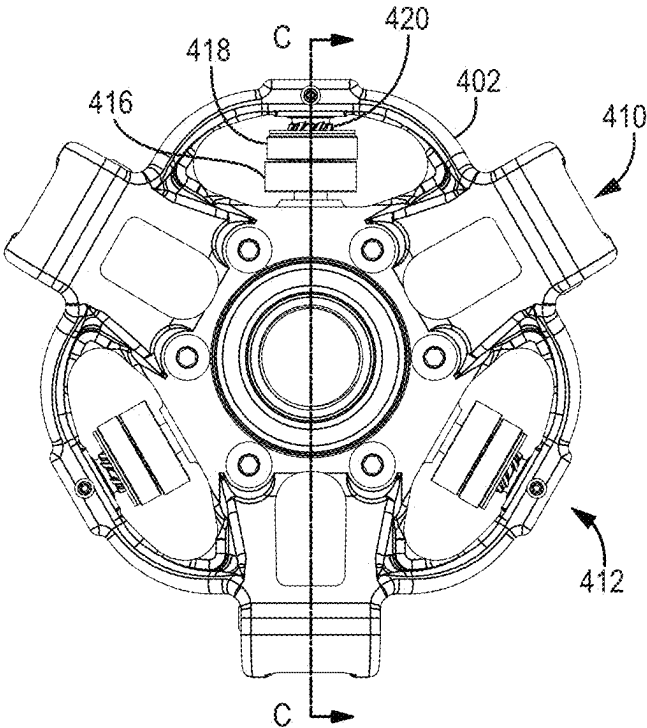
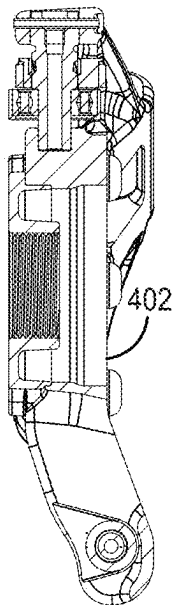

FIG. 5E



SECTION C-C

FIG. 5F

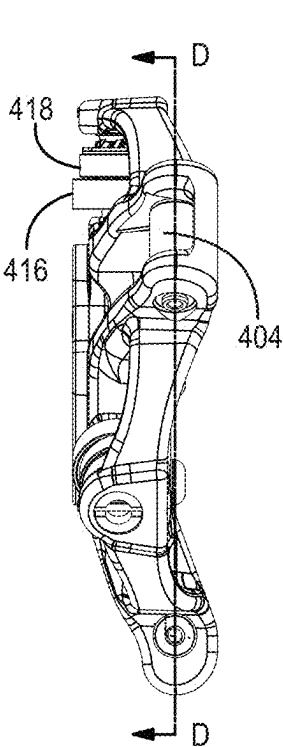
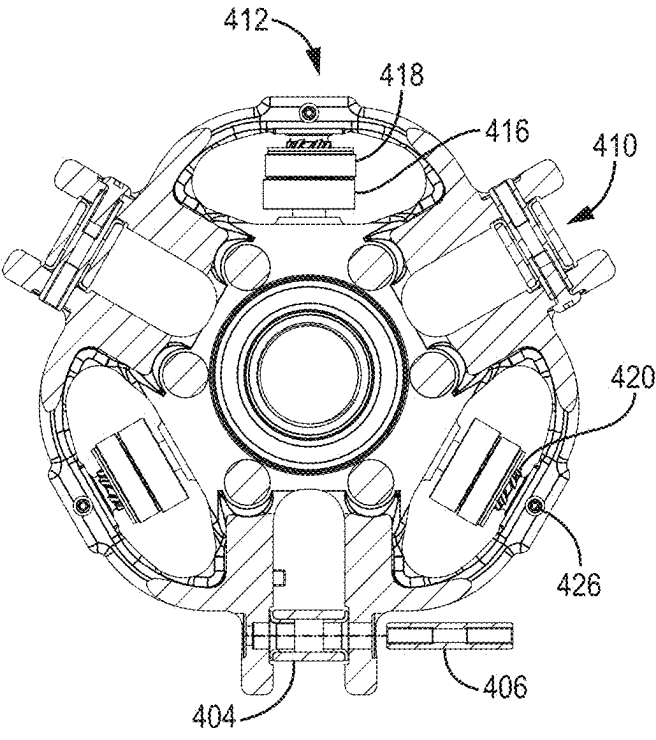

FIG. 5G



SECTION D-D

FIG. 5H

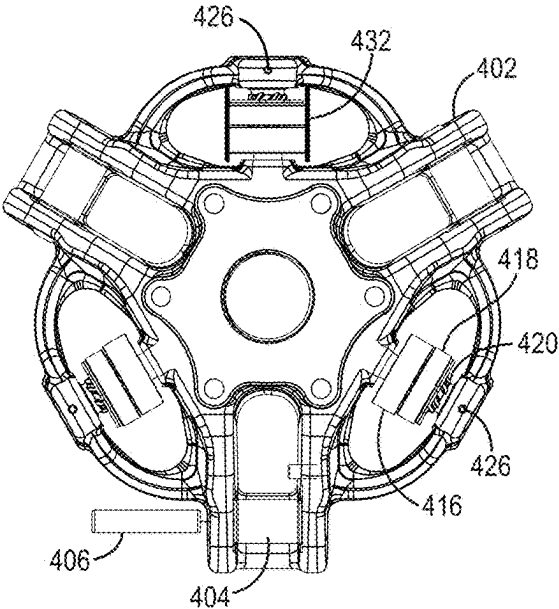

FIG. 5I

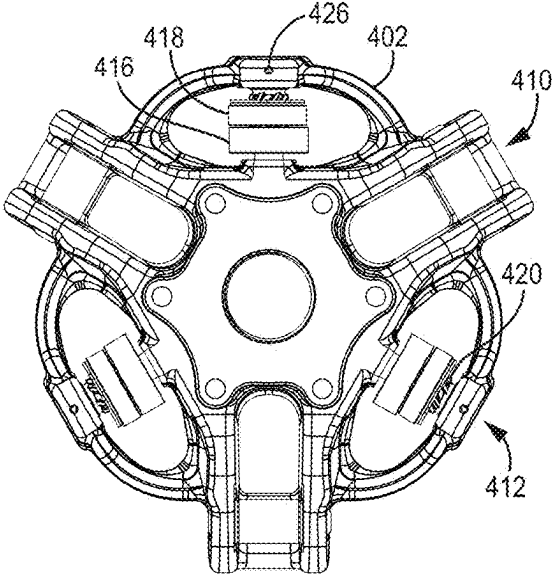

FIG. 5J

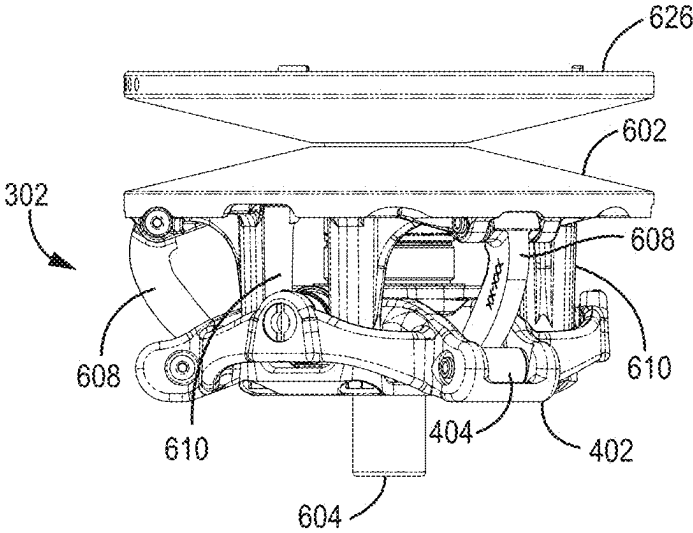

FIG. 6A

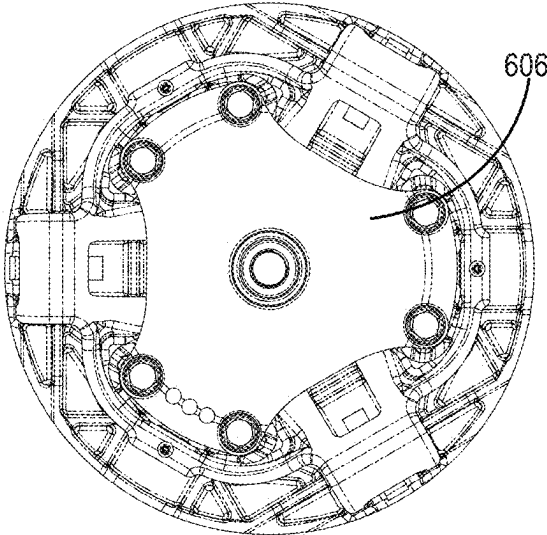

FIG. 6B

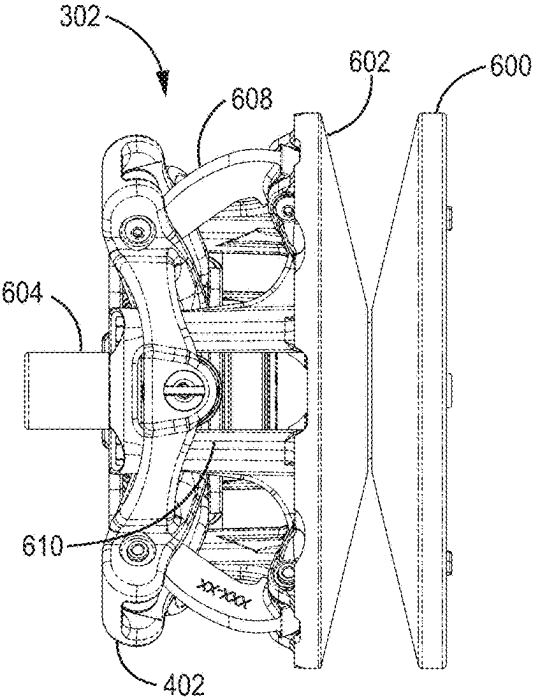

FIG. 6C

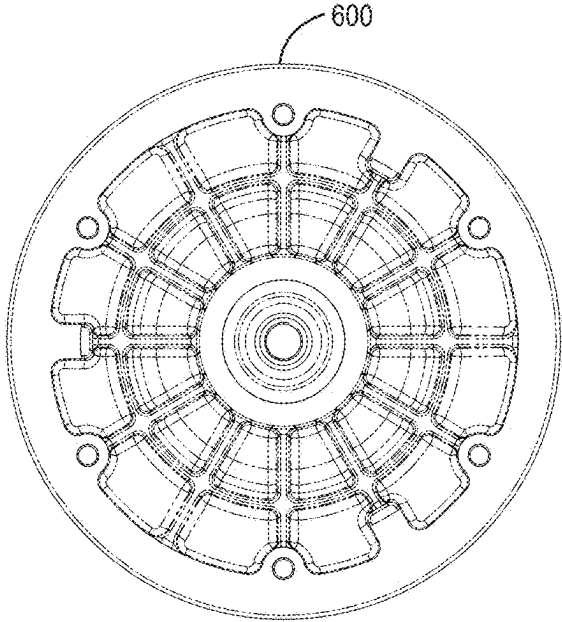

FIG. 6D

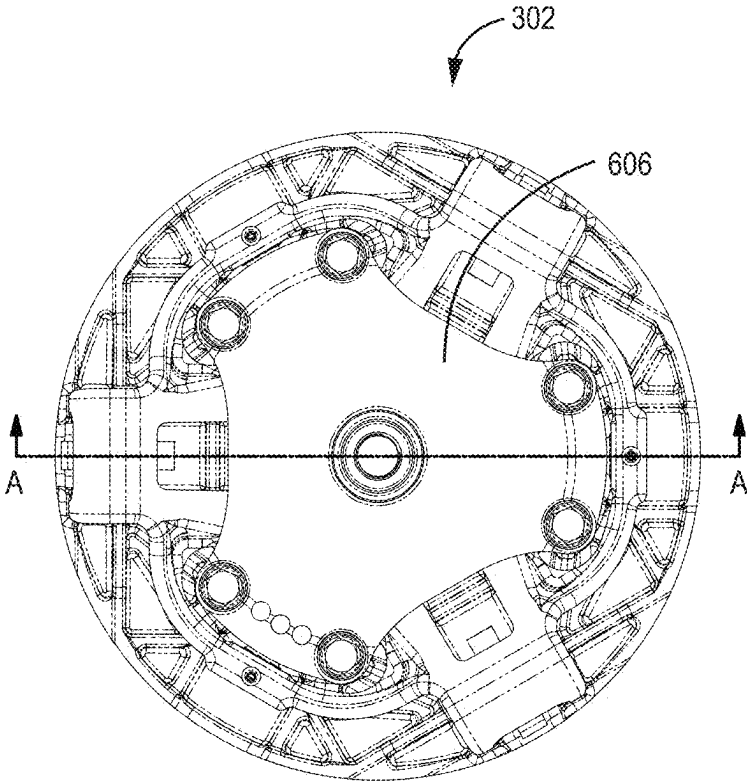
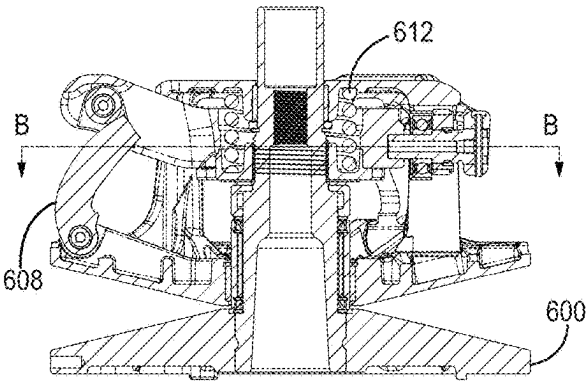
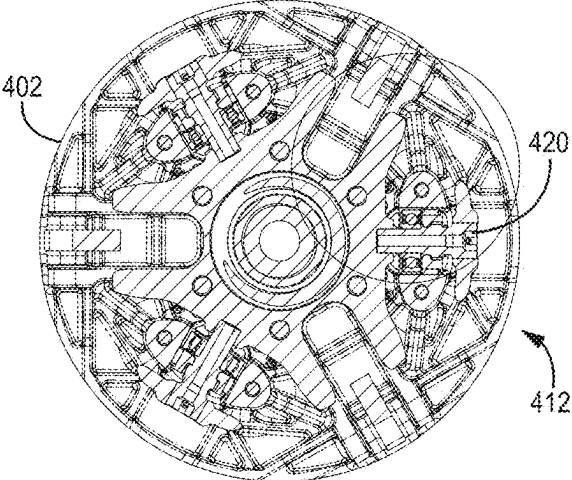

FIG. 6E



SECTION A-A
FIG. 6F



SECTION B-B
FIG. 6G

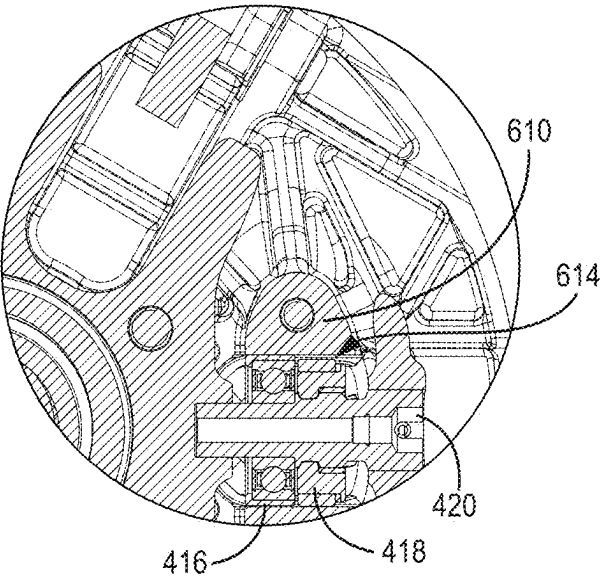

FIG. 6H

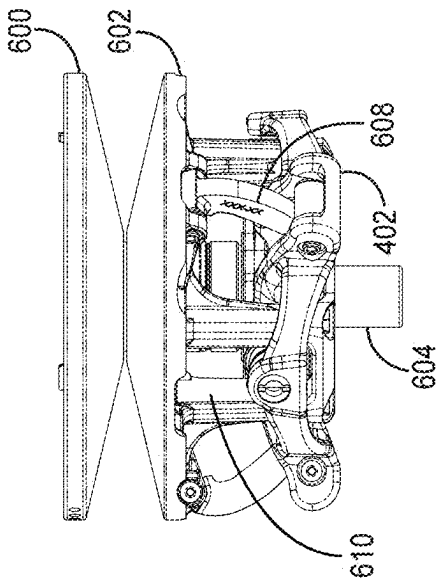

FIG. 7A

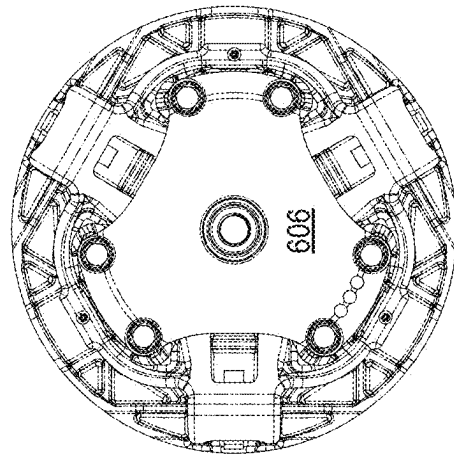

FIG. 7B

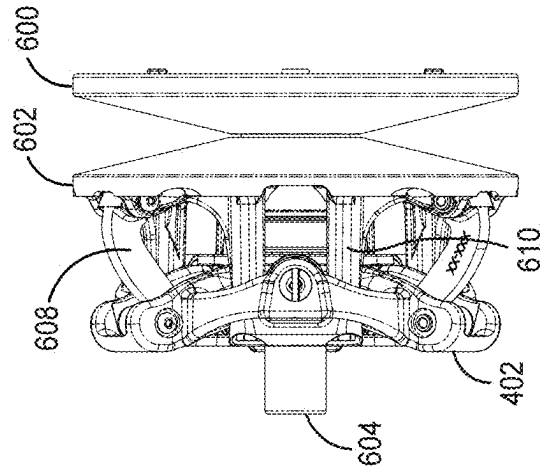

FIG. 7C

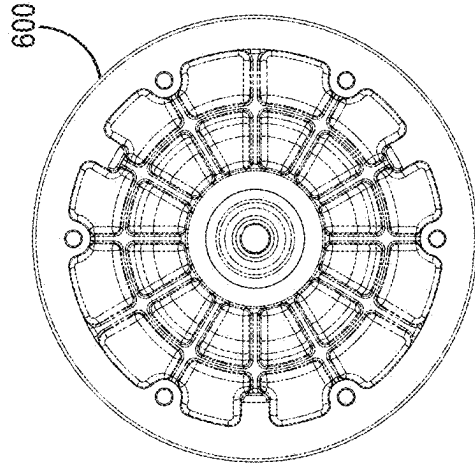

FIG. 7D

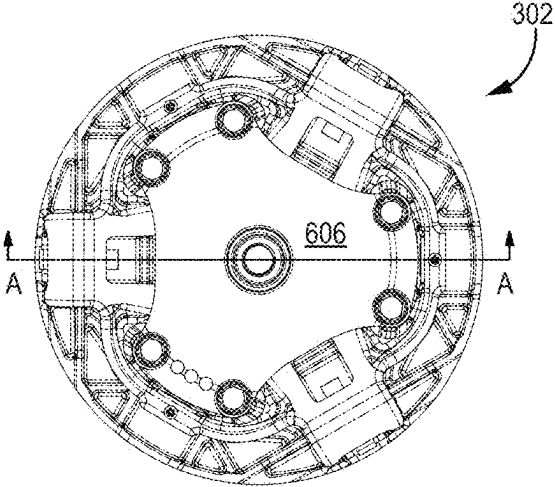
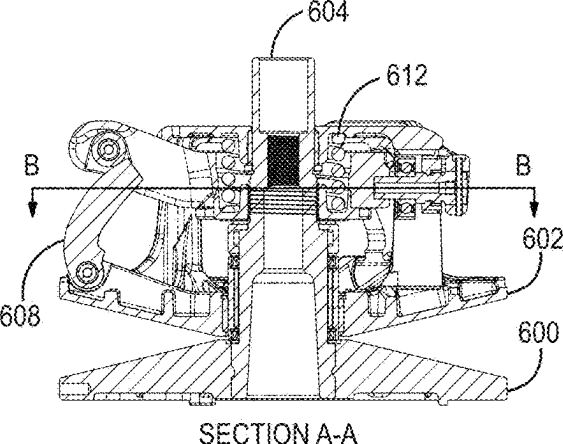
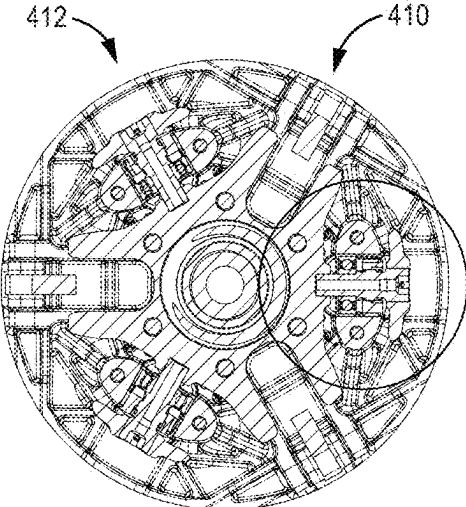

FIG. 7E



SECTION A-A

FIG. 7F



SECTION B-B

FIG. 7G

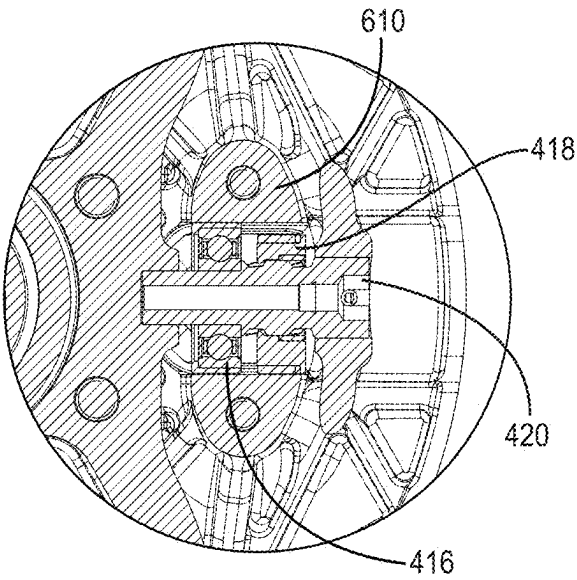

FIG. 7H

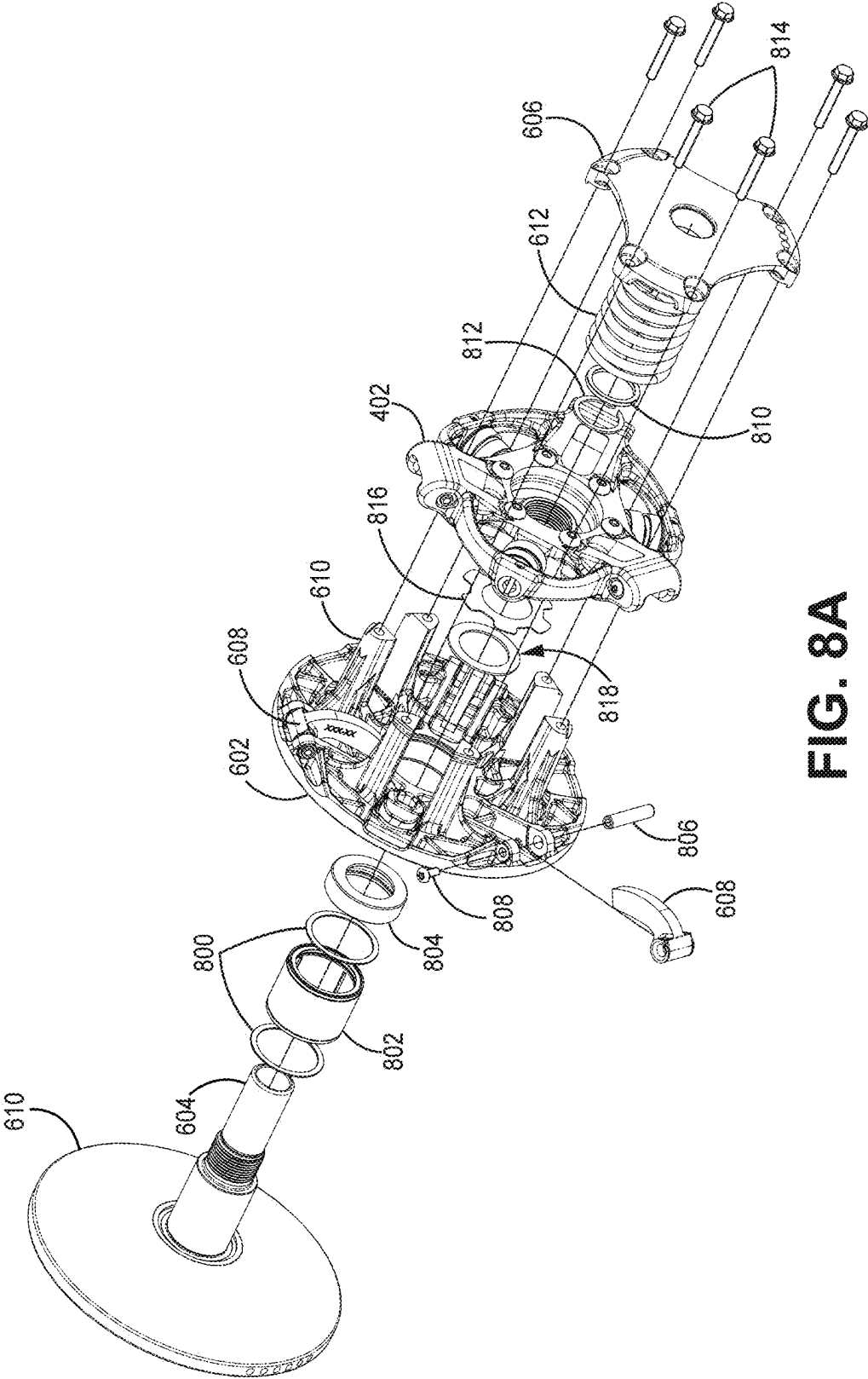

FIG. 8A

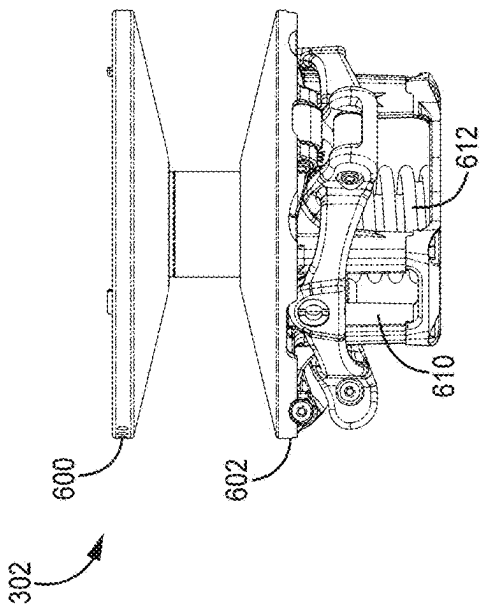

FIG. 8B

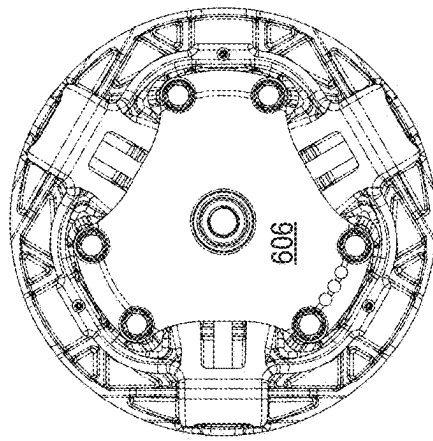

FIG. 8C

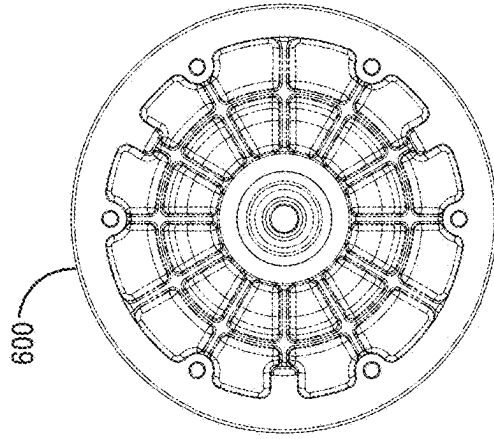

FIG. 8E

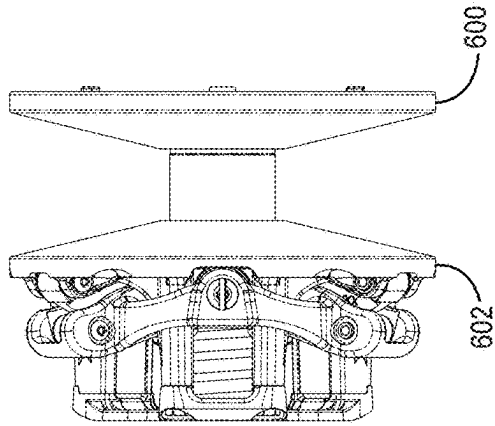

FIG. 8D

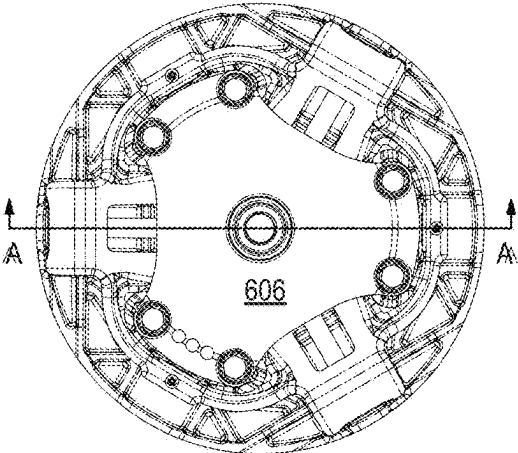
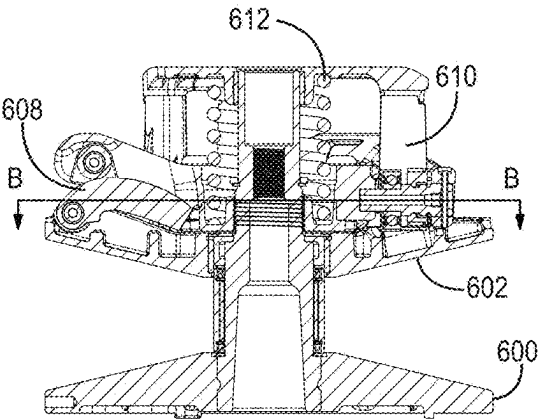
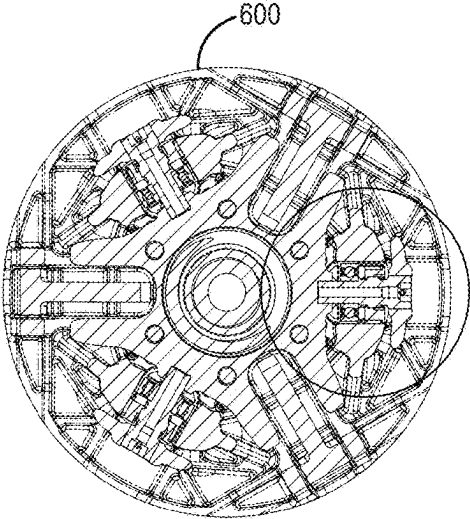

FIG. 8F



SECTION A-A

FIG. 8G



SECTION B-B

FIG. 8H

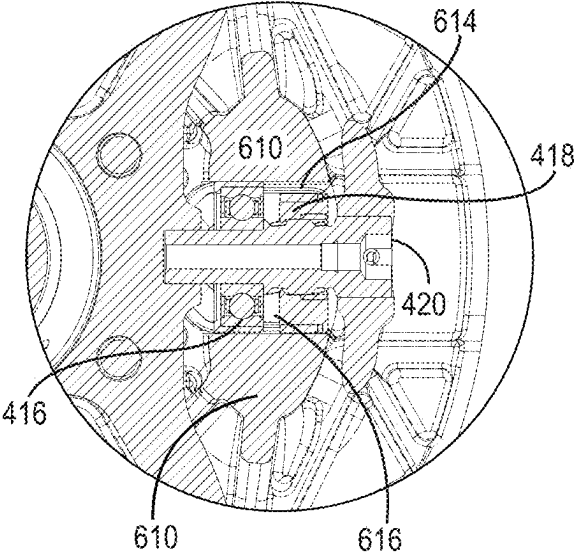

FIG. 8I

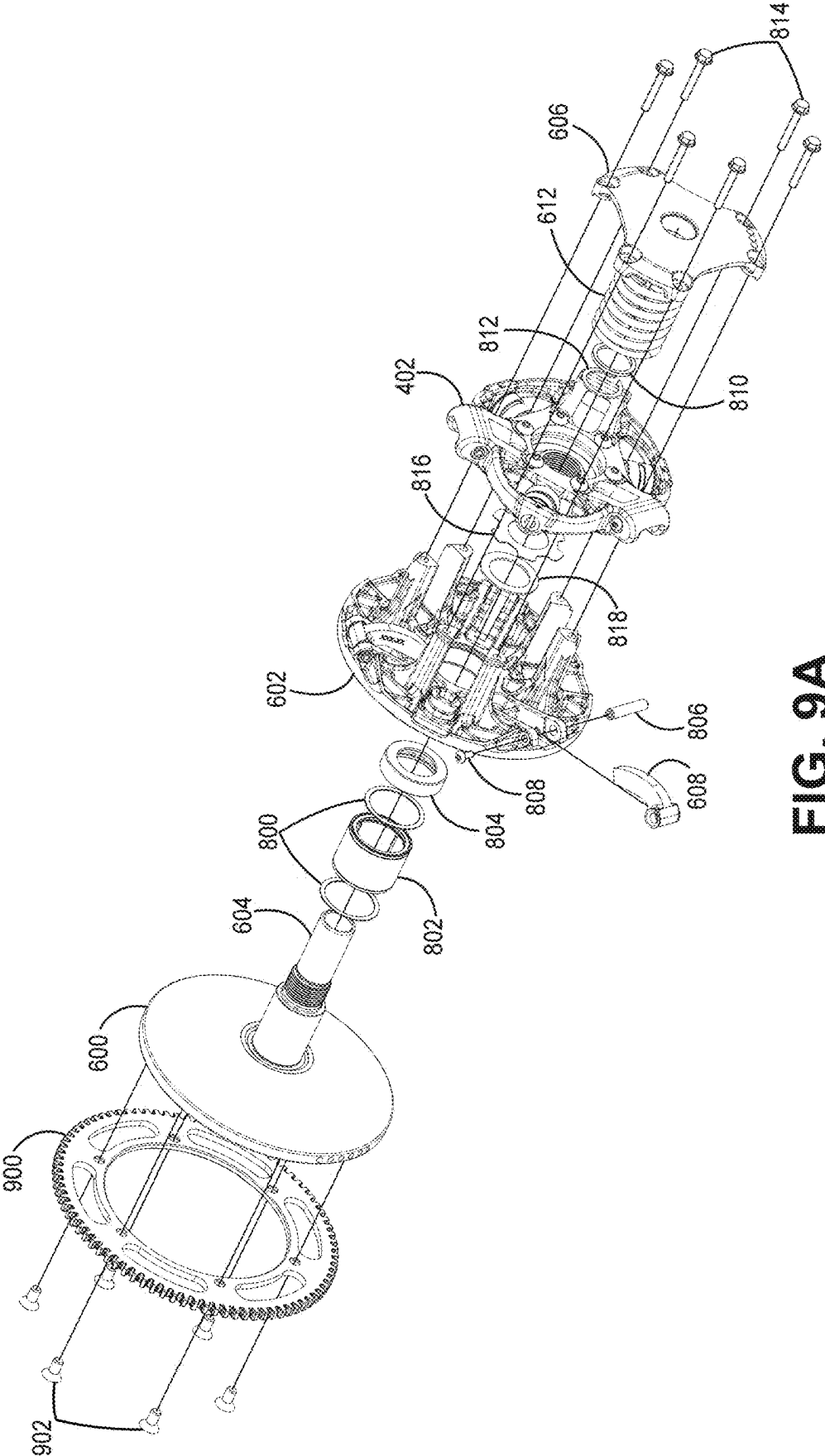

FIG. 9A

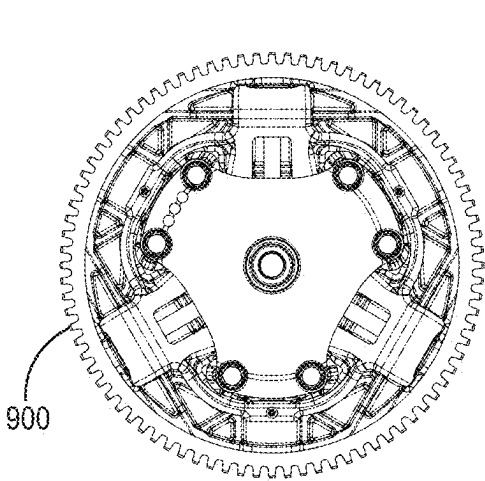

FIG. 9B

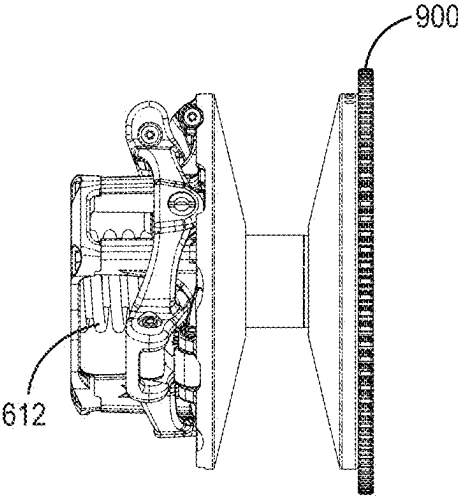

FIG. 9E

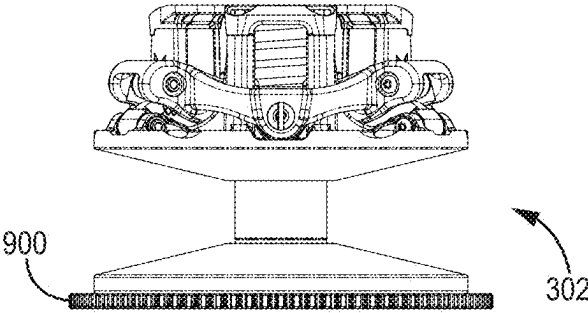

FIG. 9C

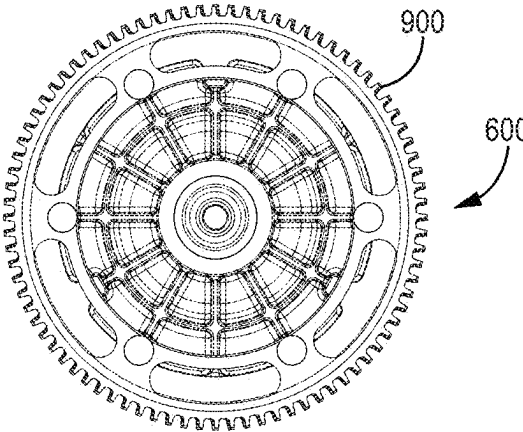

FIG. 9D

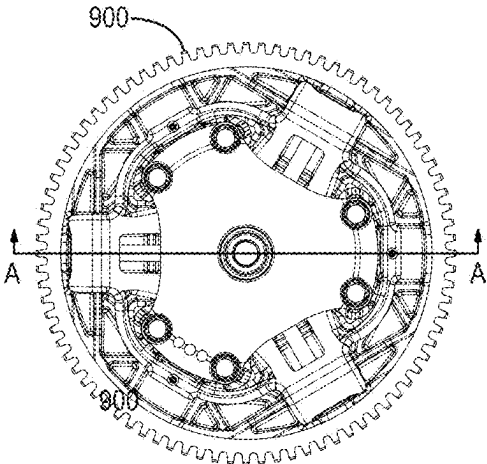

FIG. 9F

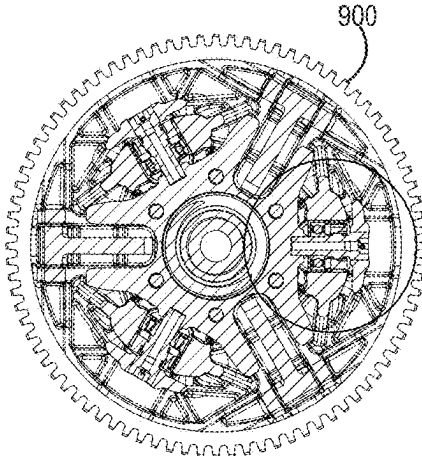

FIG. 9H

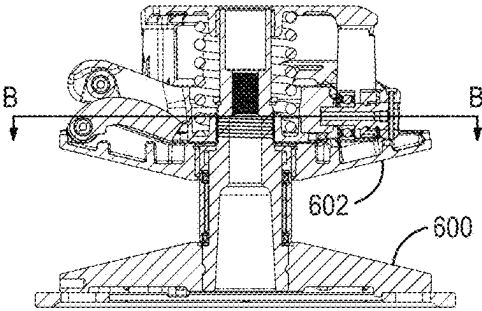

FIG. 9G

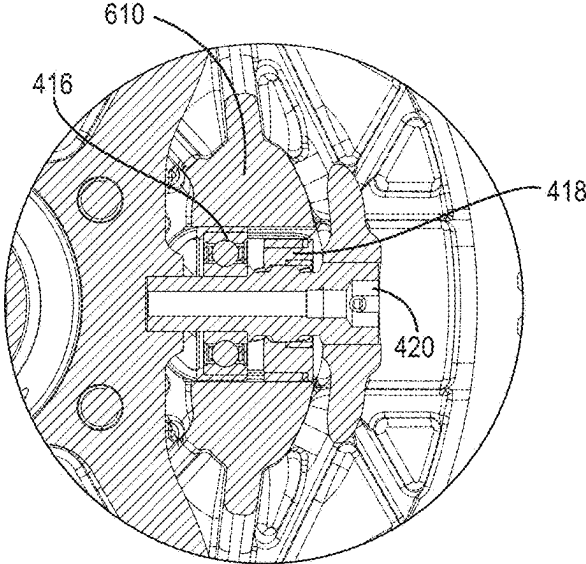

FIG. 9I

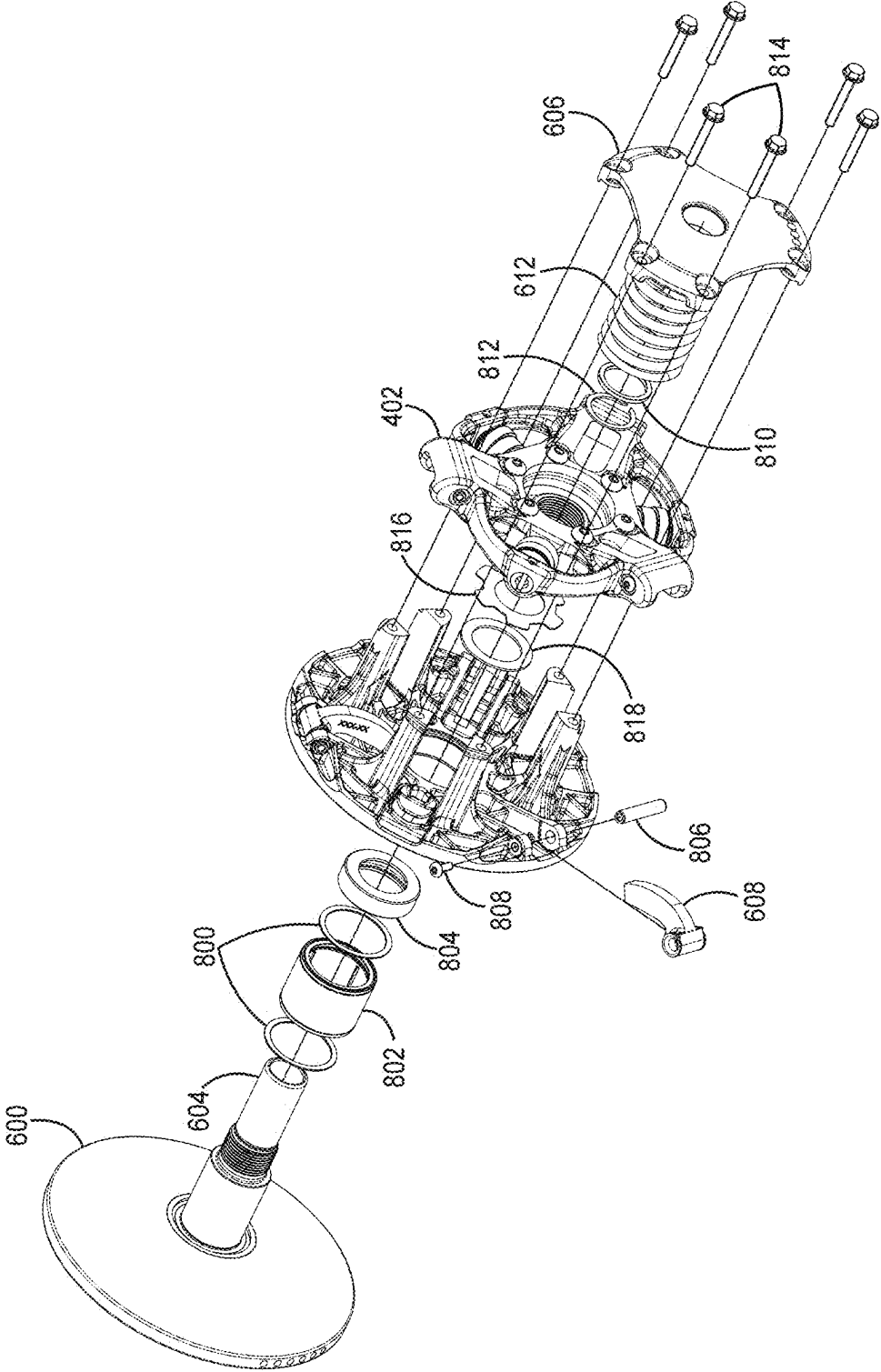

FIG. 10A

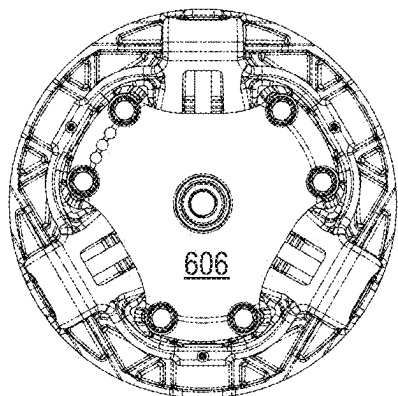

FIG. 10B

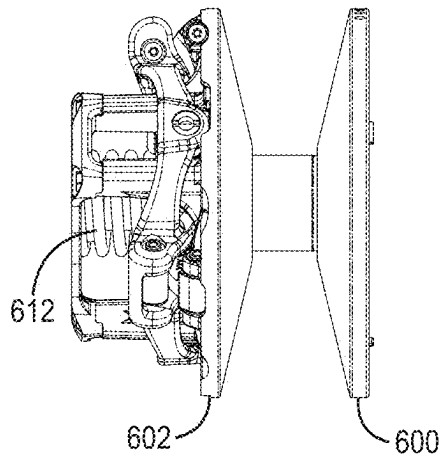

FIG. 10E

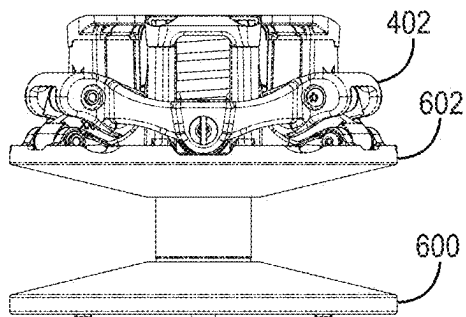

FIG. 10C

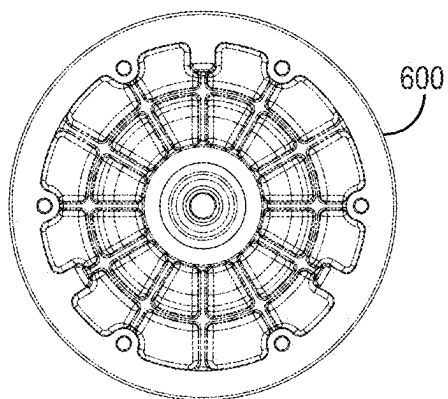

FIG. 10D

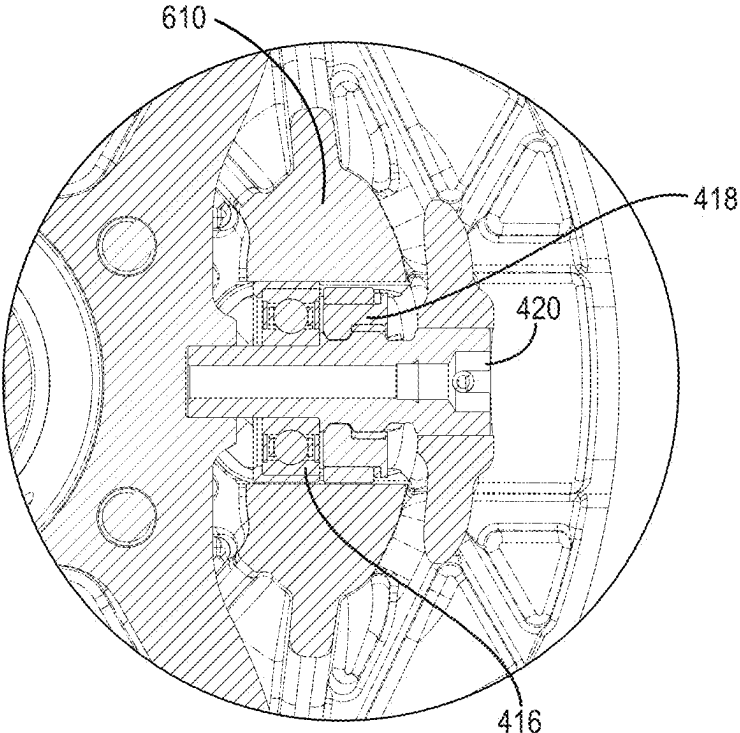

FIG. 10F

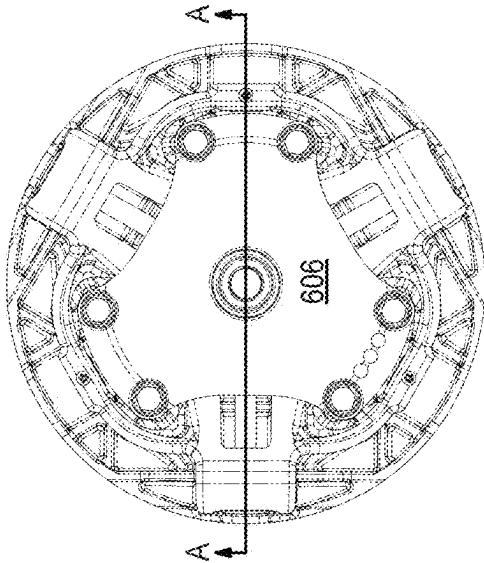
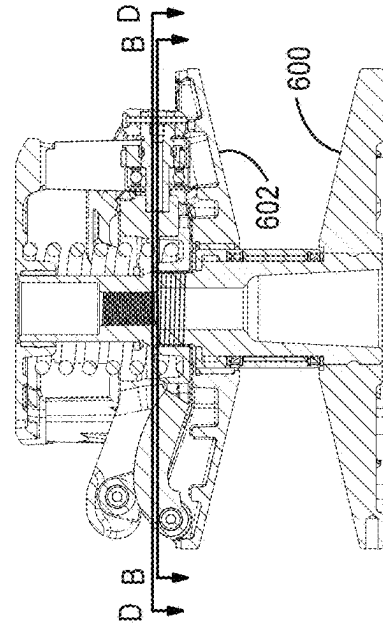
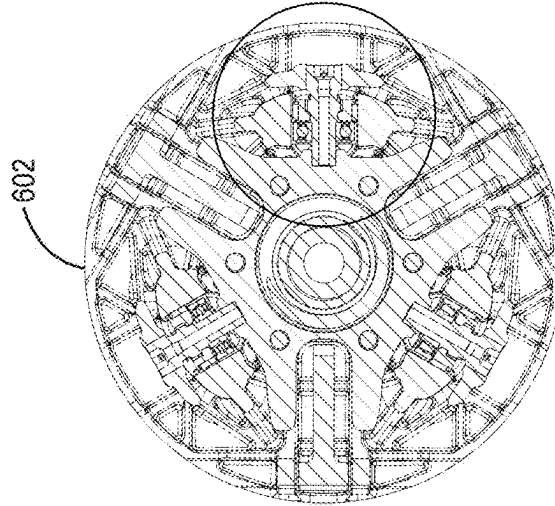

FIG. 10G



SECTION A-A

FIG. 10H



SECTION B-B

FIG. 10I

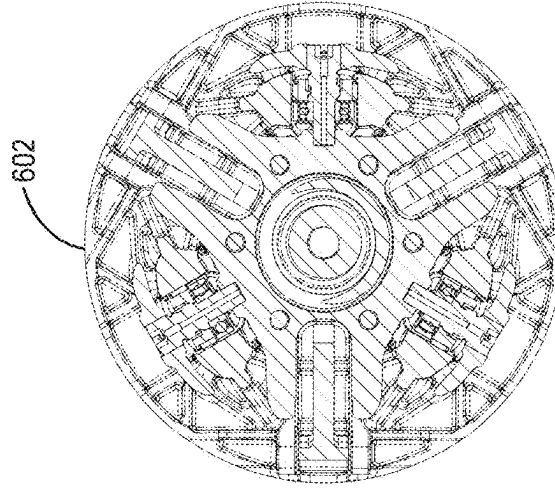

SECTION D-D

FIG. 10J

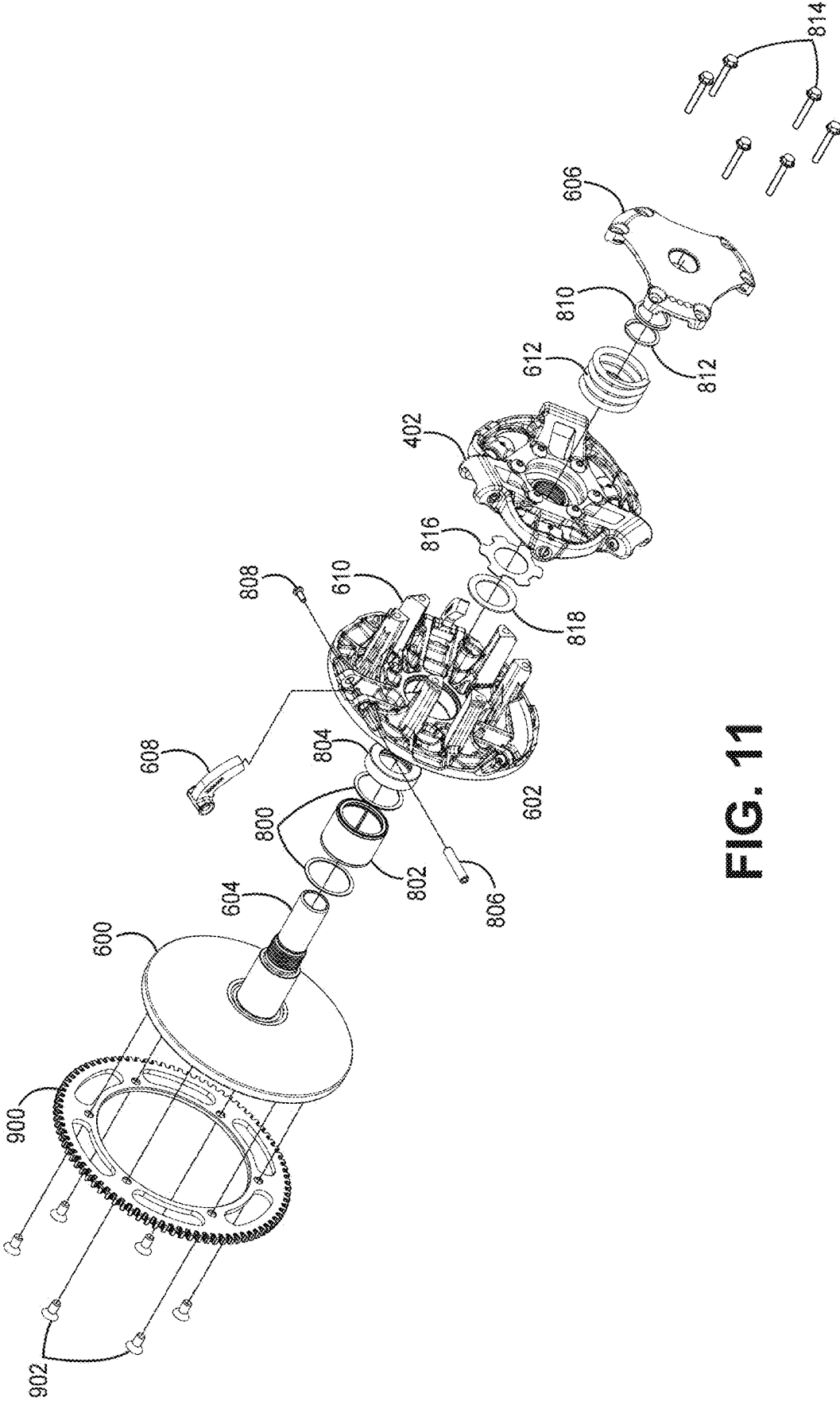

FIG. 11

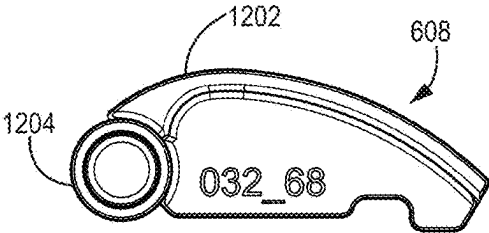

FIG. 12A

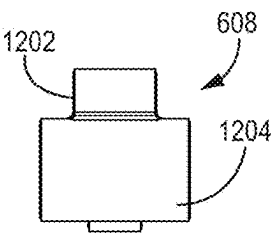

FIG. 12C

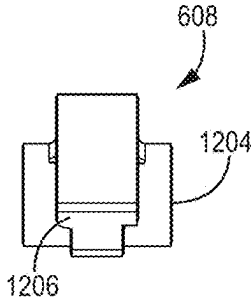

FIG. 12E

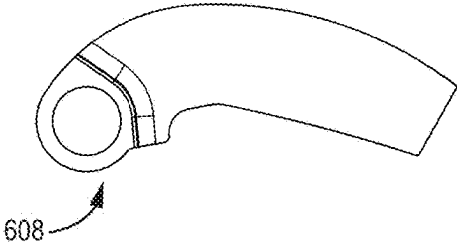

FIG. 12B

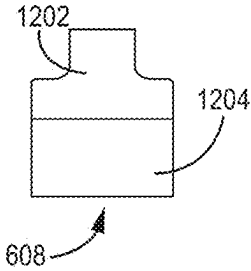

FIG. 12D

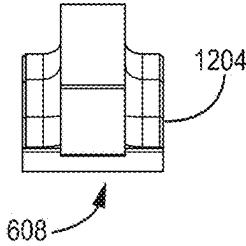

FIG. 12F

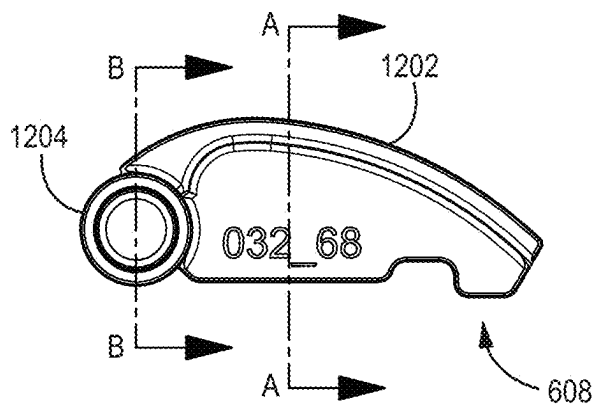
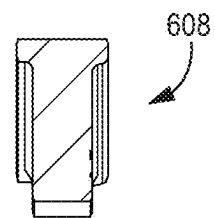
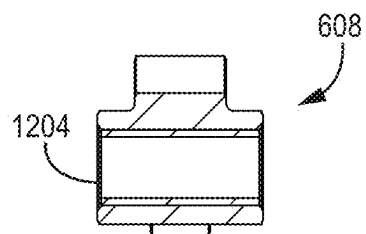

FIG. 12G



SECTION A-A

FIG. 12H



SECTION B-B

FIG. 12I

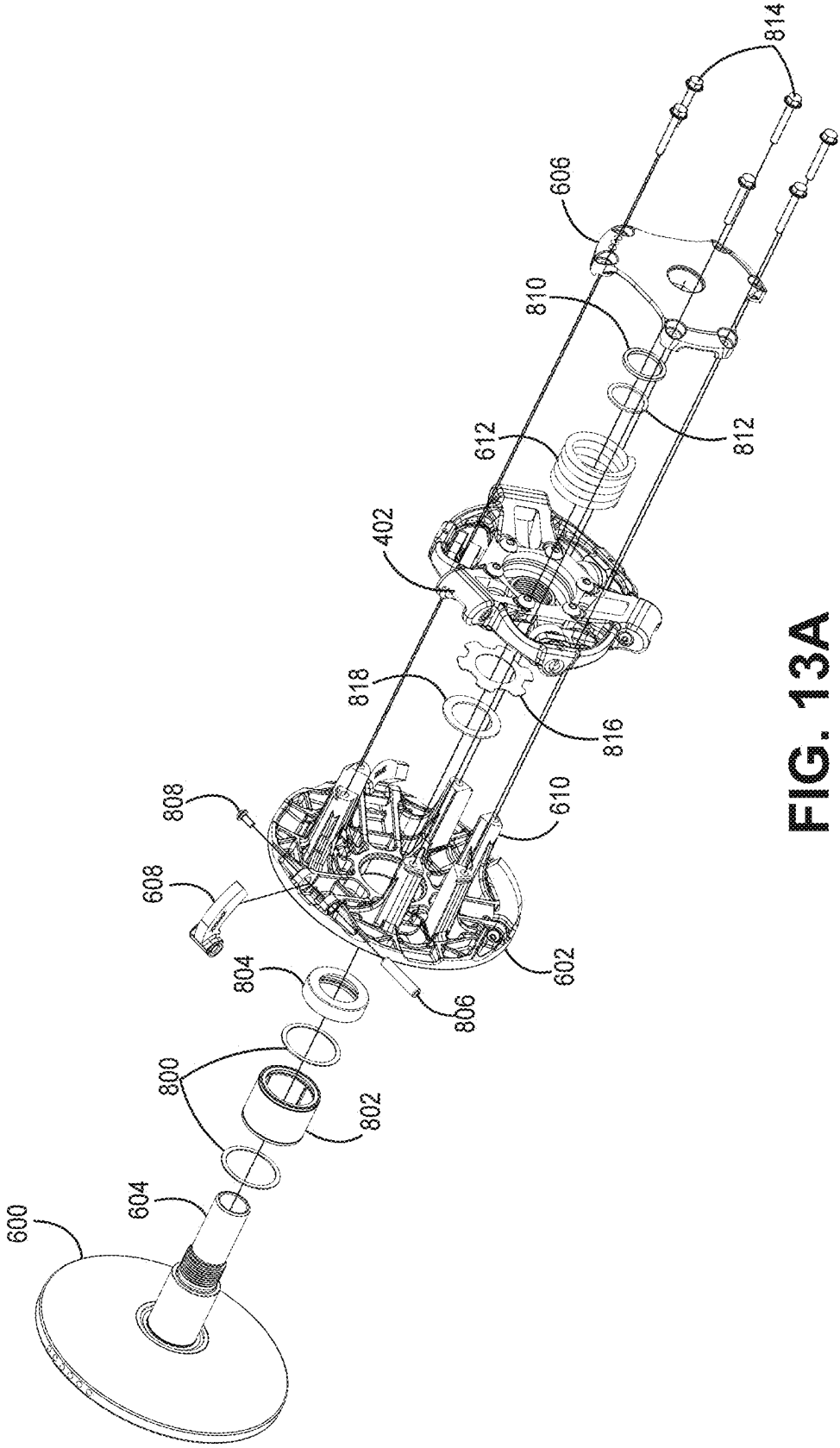

FIG. 13A

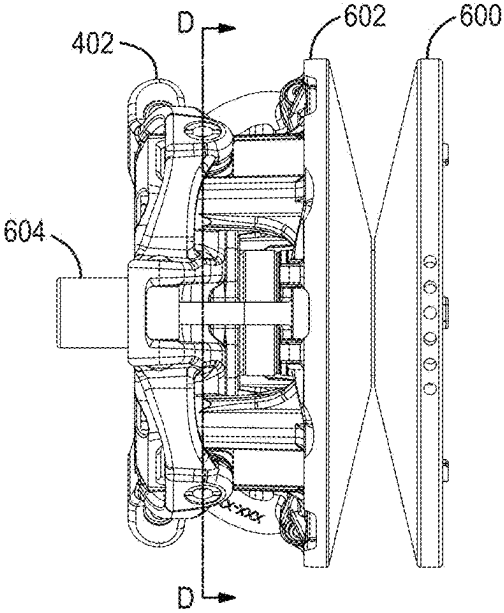
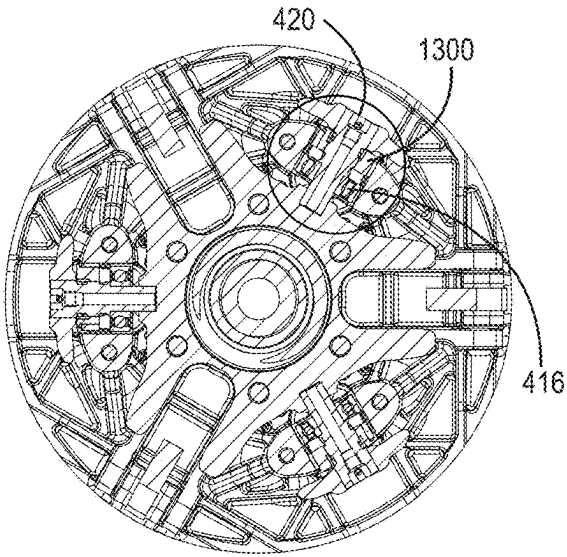
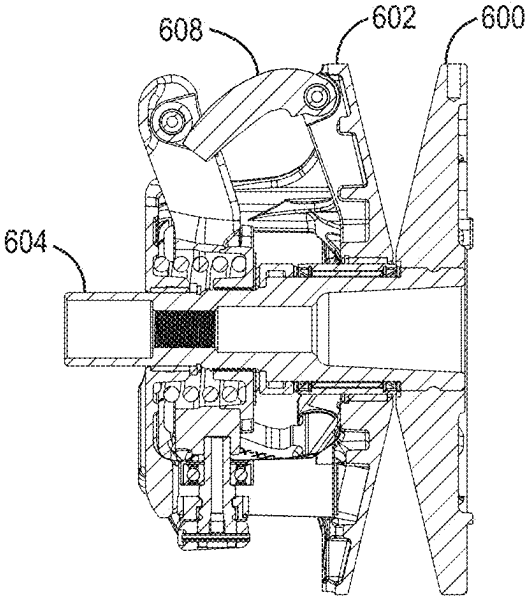

FIG. 13B



SECTION D-D

FIG. 13C



SECTION F-F

FIG. 13D

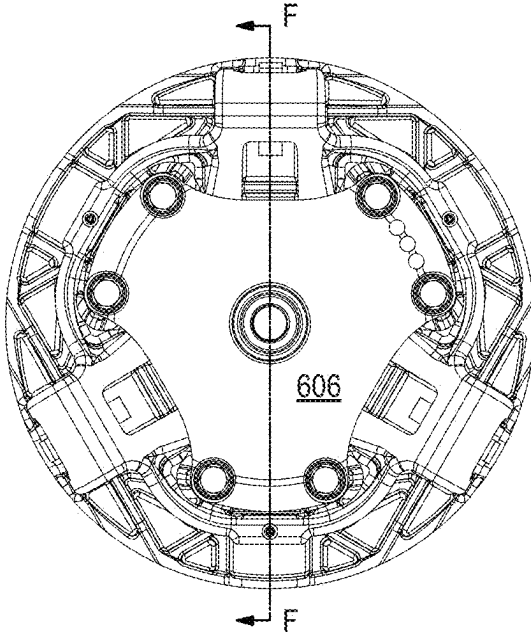

FIG. 13E

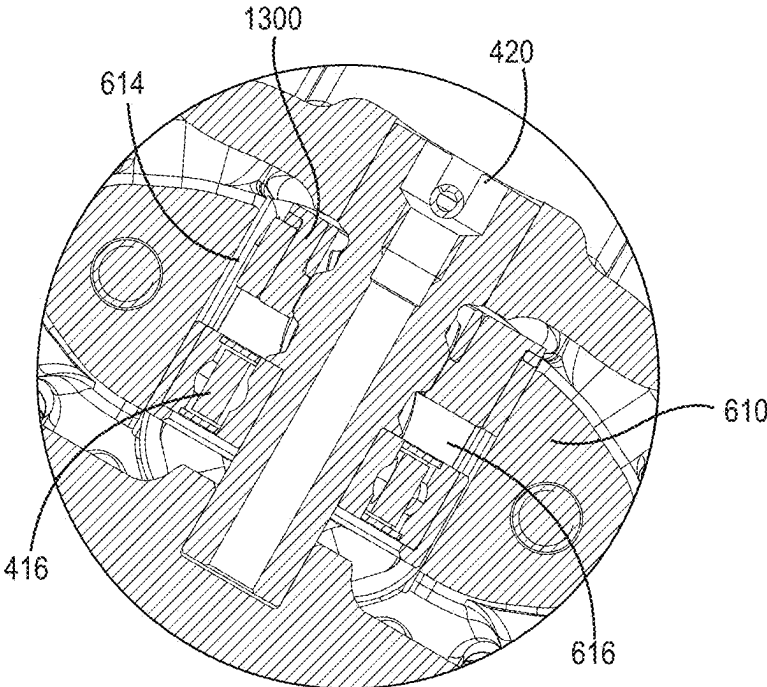

FIG. 13F

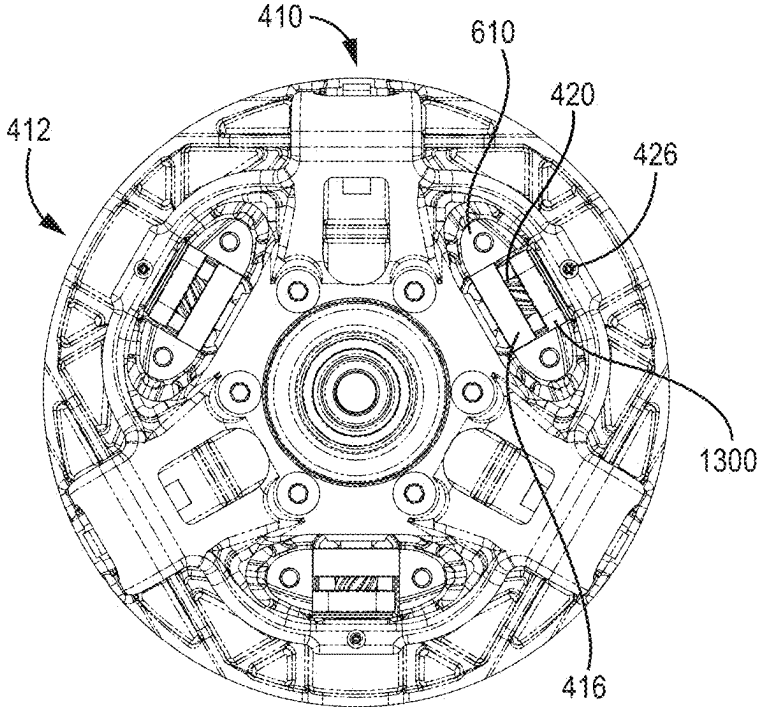

FIG. 13G

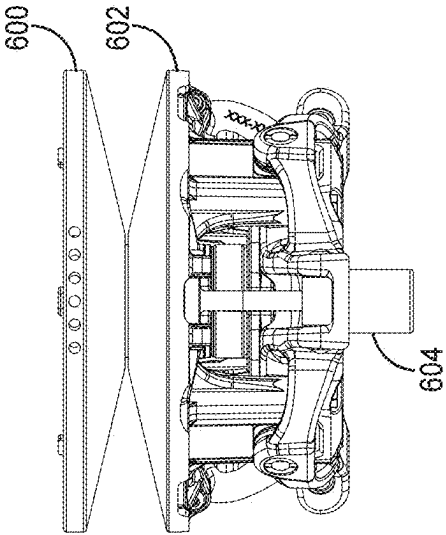

FIG. 13H

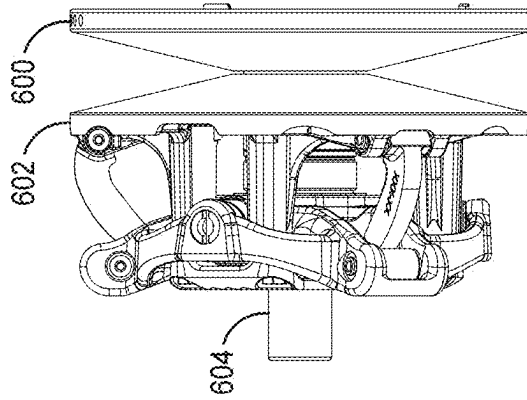

FIG. 13J

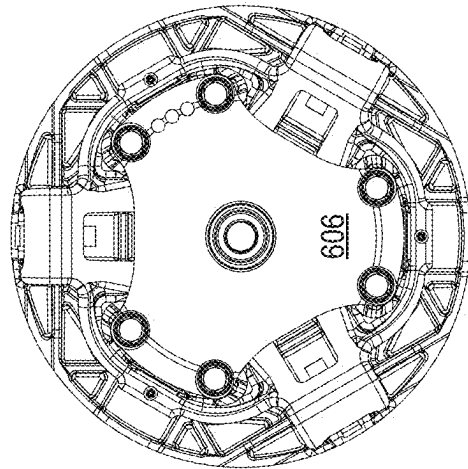

FIG. 13I

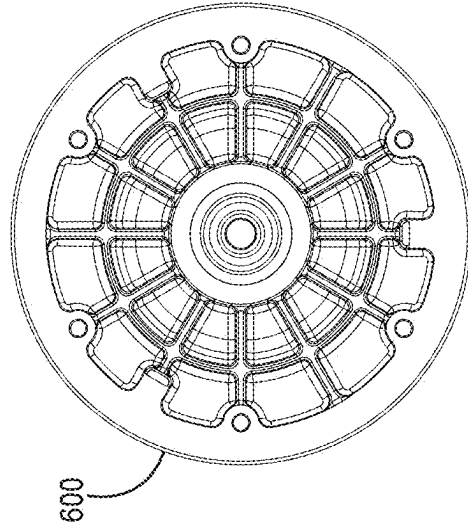

FIG. 13K

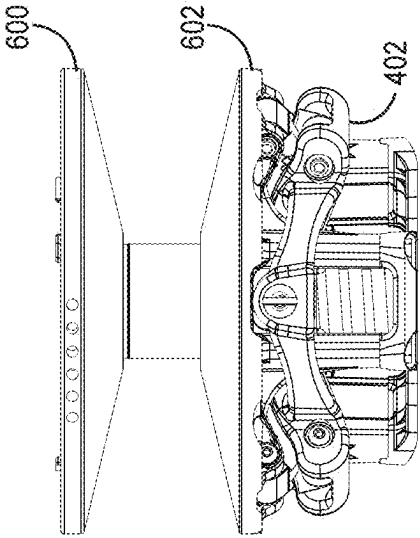

FIG. 14A

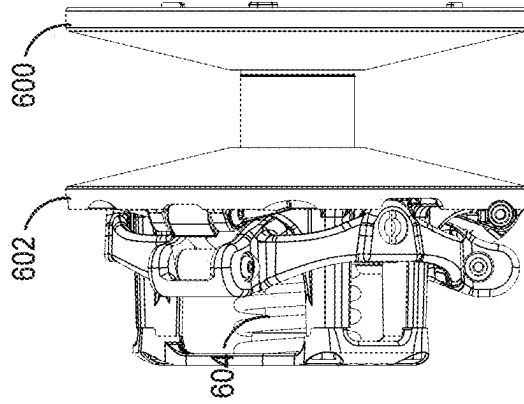

FIG. 14C

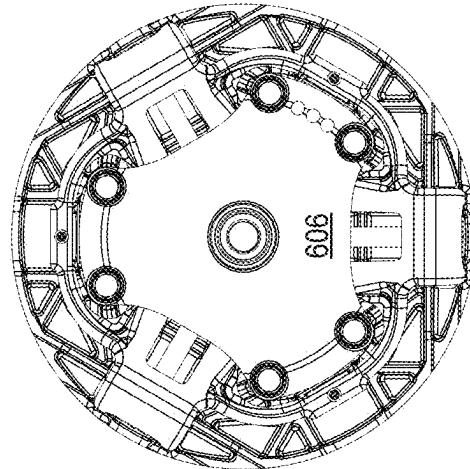

FIG. 14B

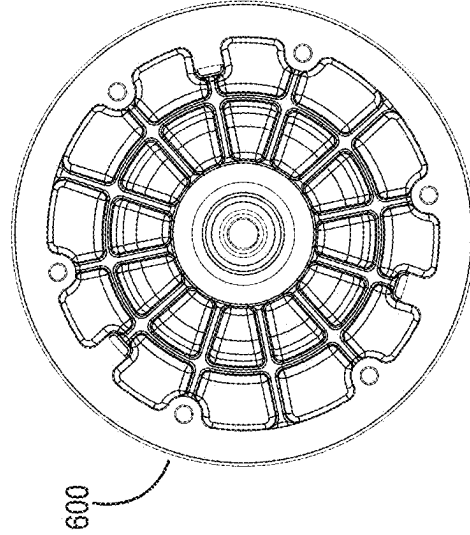

FIG. 14D

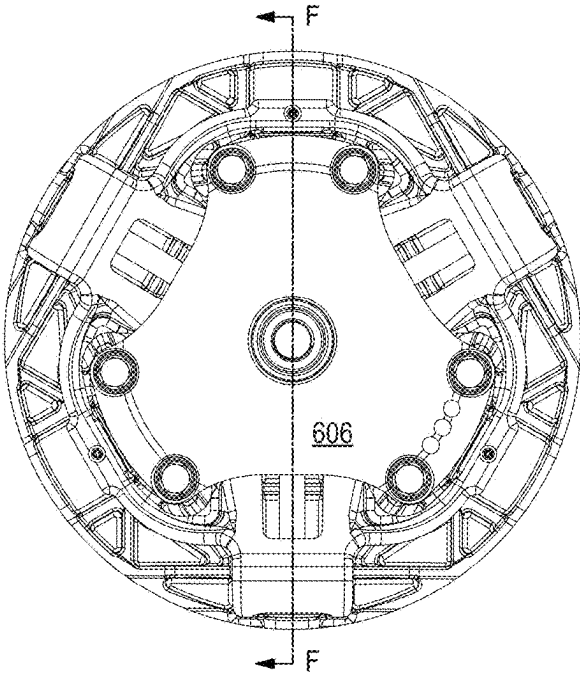
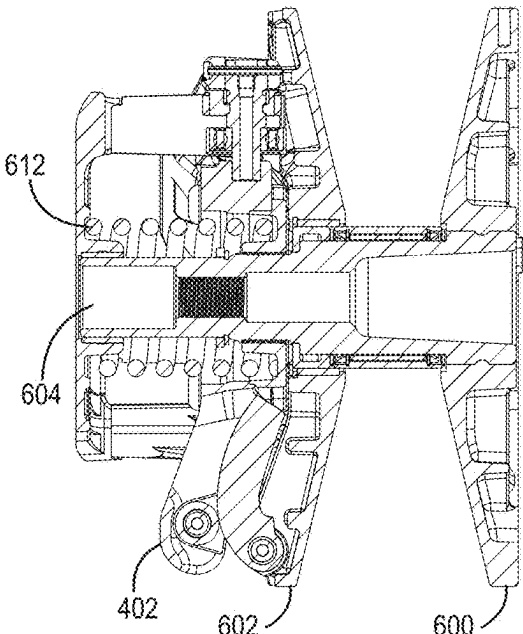
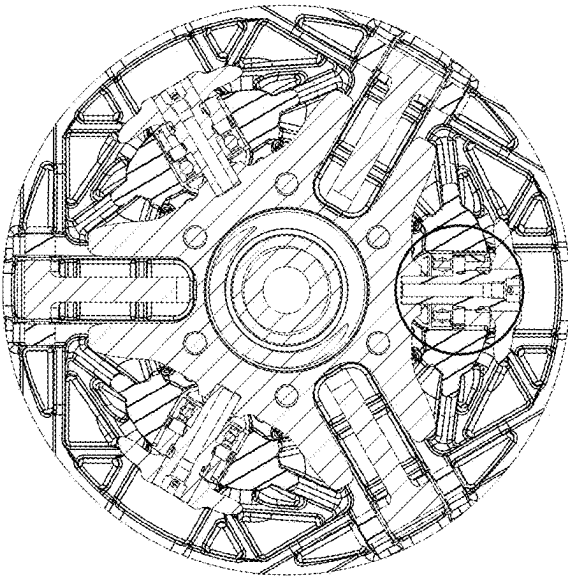

FIG. 14E



SECTION F-F

FIG. 14F



SECTION D-D

FIG. 14G

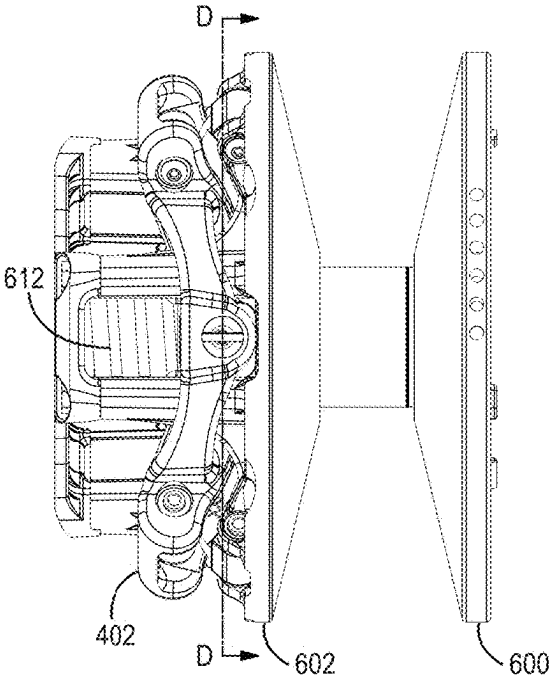

FIG. 14H

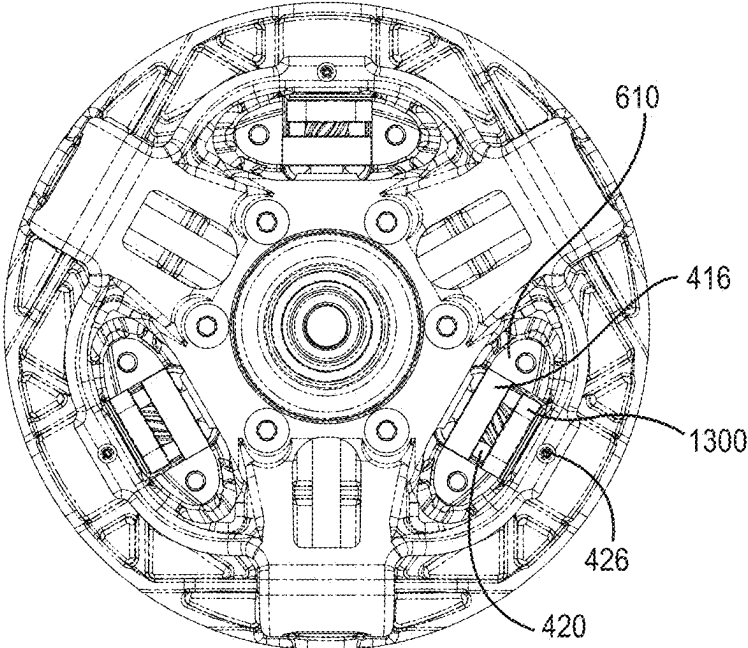

FIG. 14I

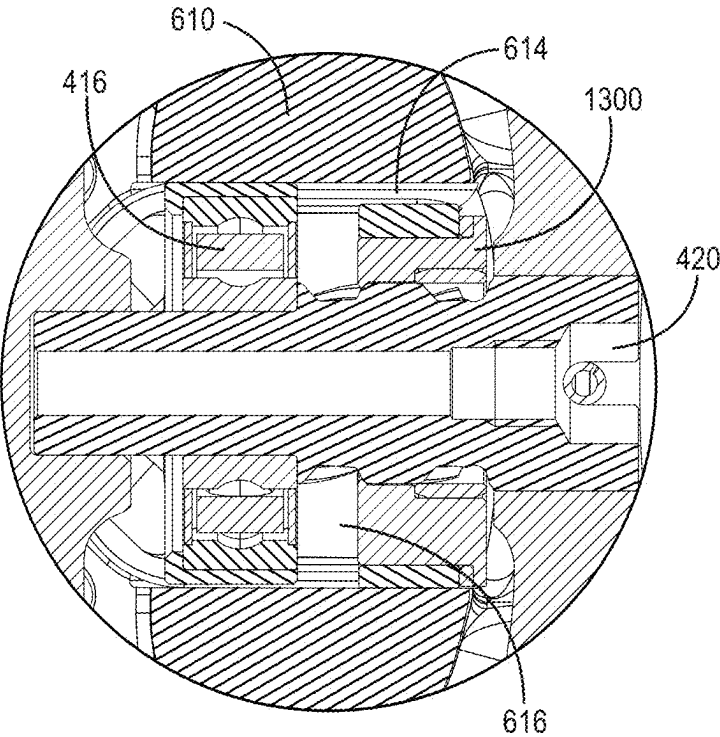

FIG. 14J

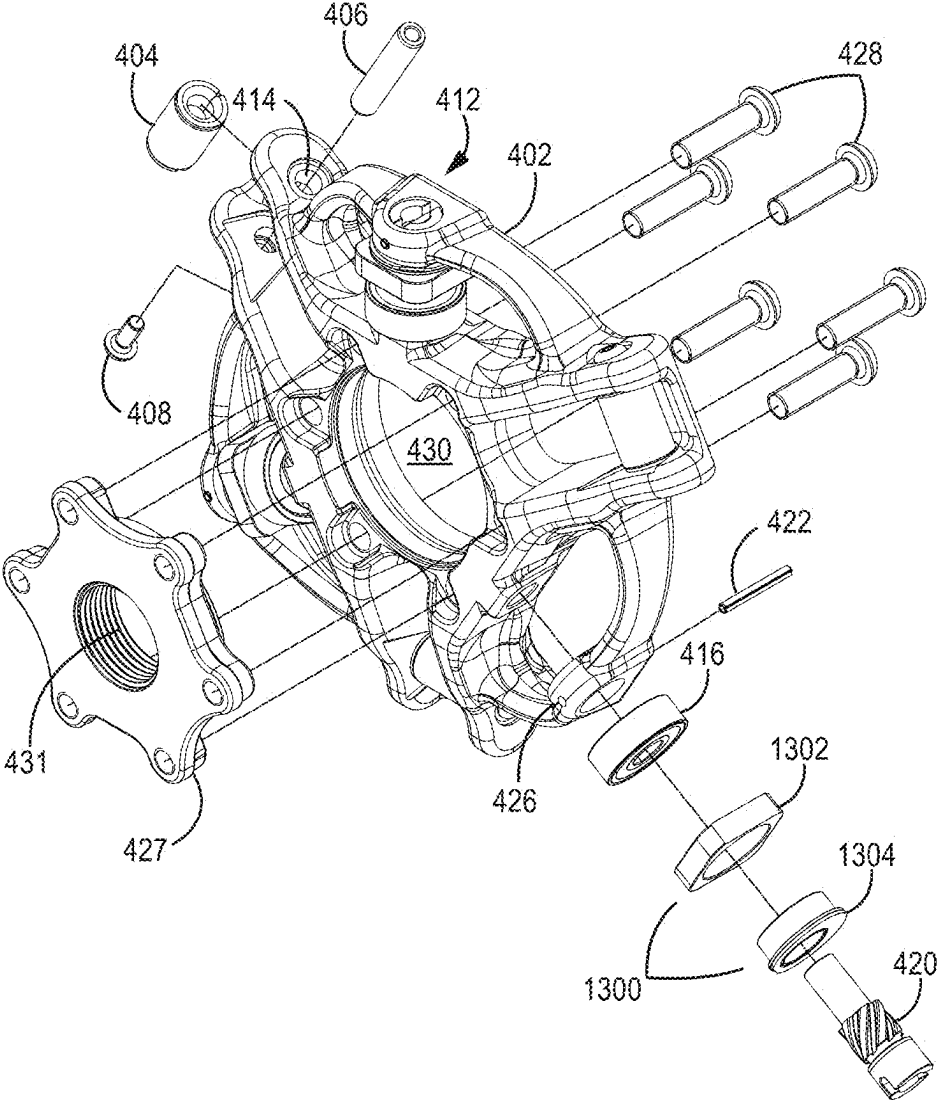

FIG. 15A

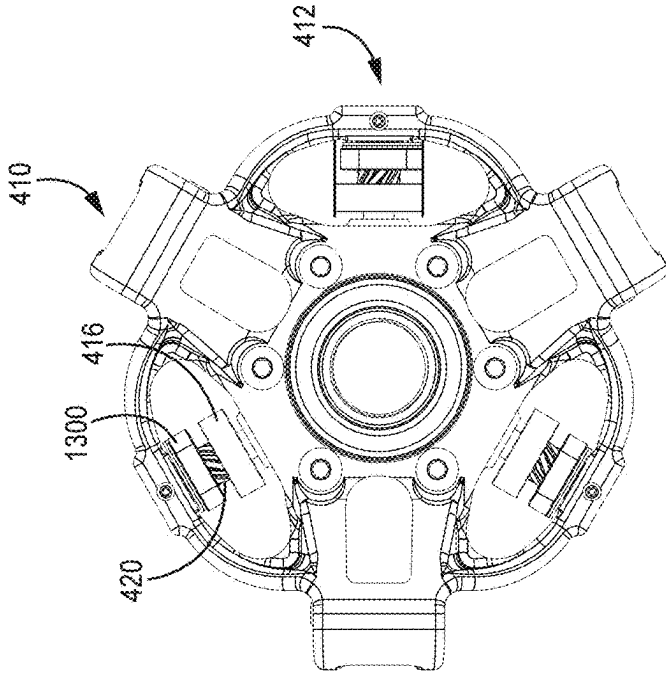

FIG. 15D

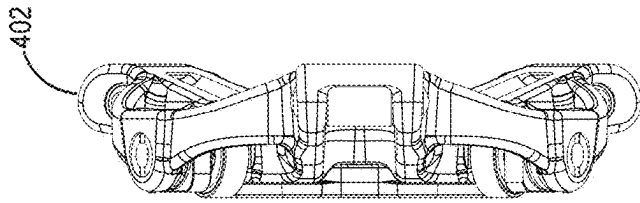

FIG. 15C

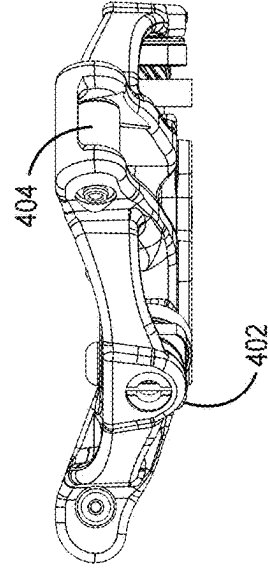

FIG. 15E

FIG. 15B

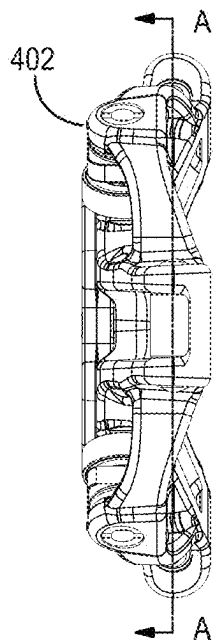
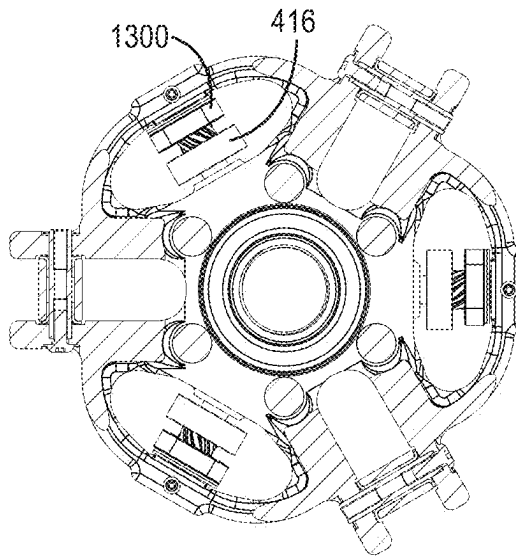

FIG. 15F



SECTION A-A

FIG. 15G

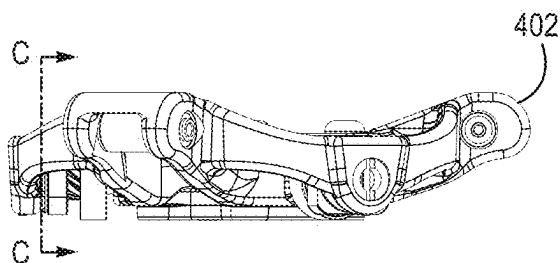
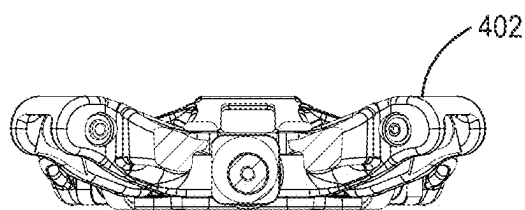

FIG. 15H



SECTION C-C

FIG. 15I

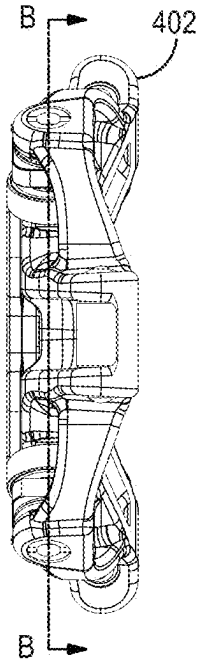

FIG. 15J

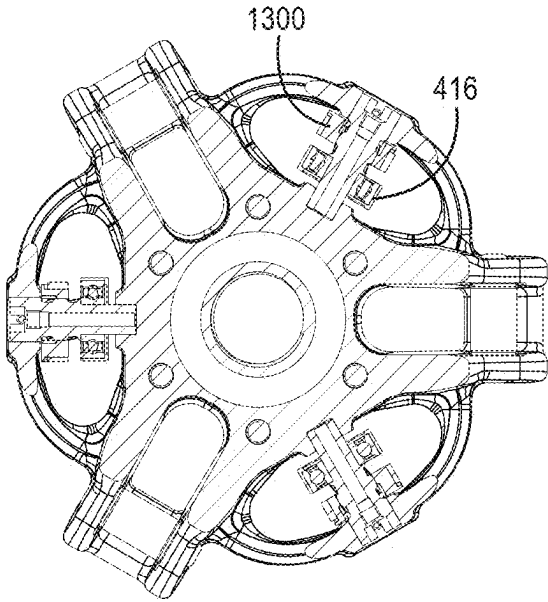

FIG. 15K

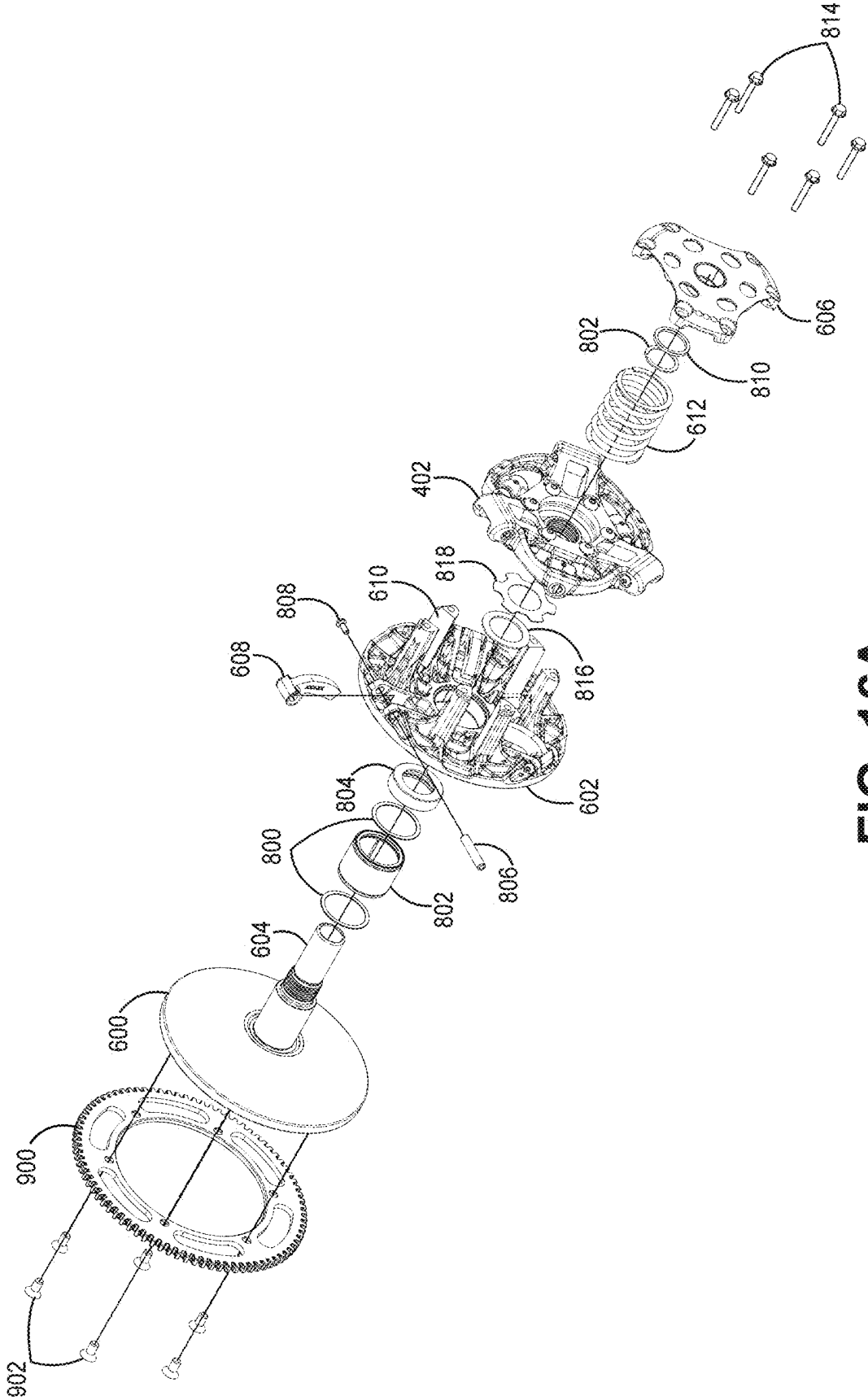

FIG. 16A

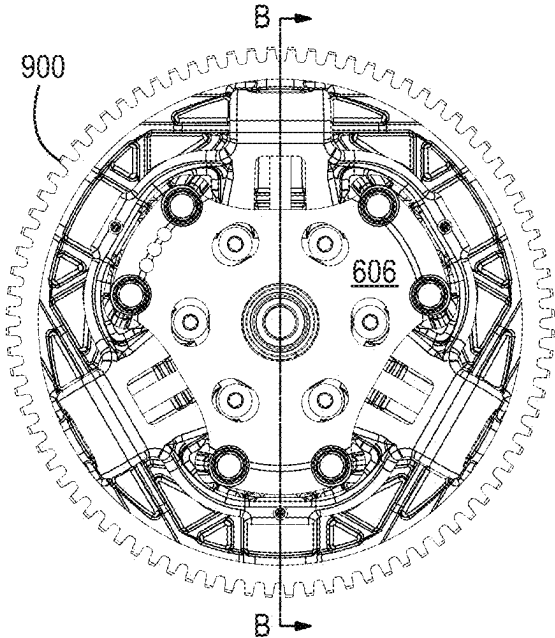
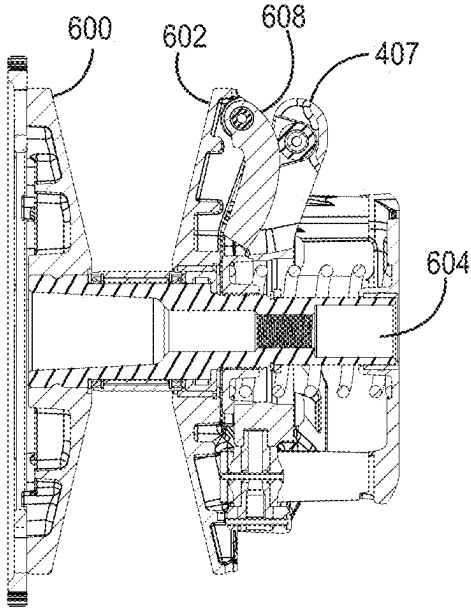

FIG. 16B



SECTION B-B

FIG. 16C

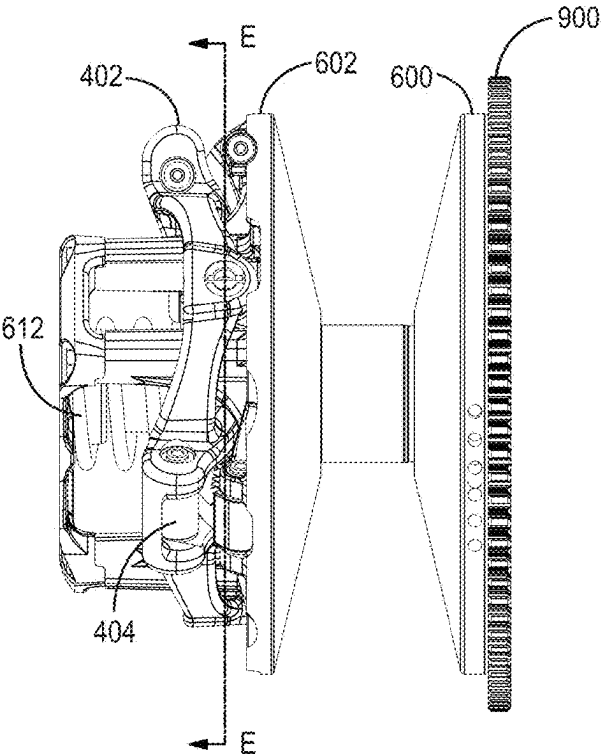
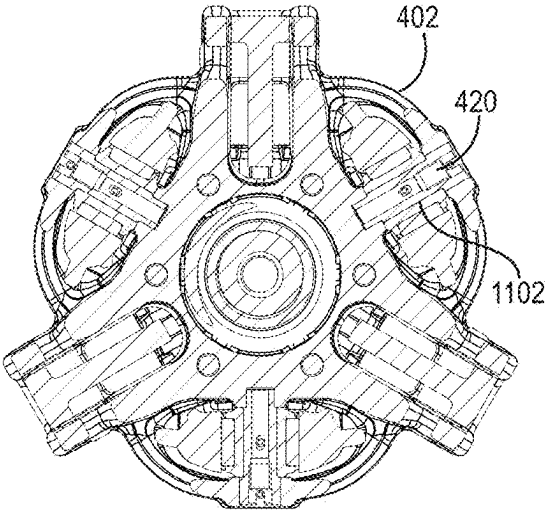
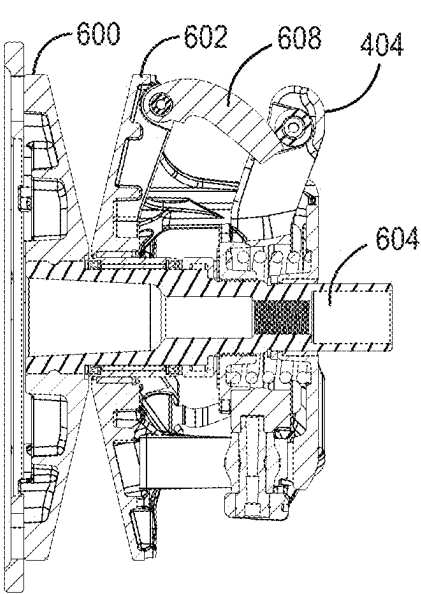

FIG. 16D



SECTION E-E

FIG. 16E



SECTION B-B

FIG. 16F

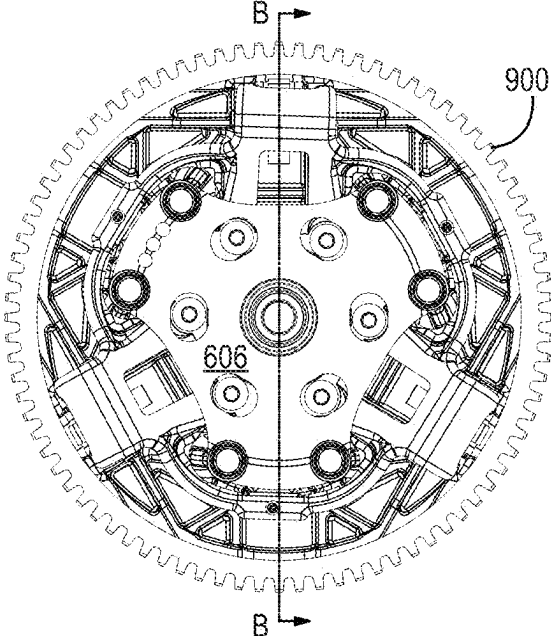

FIG. 16G

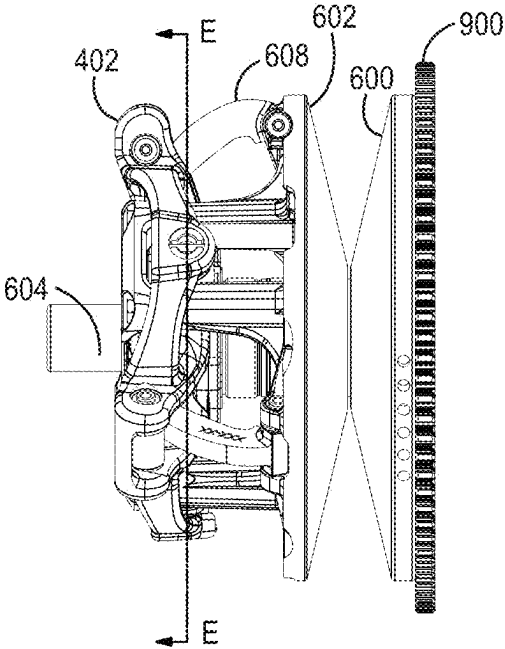
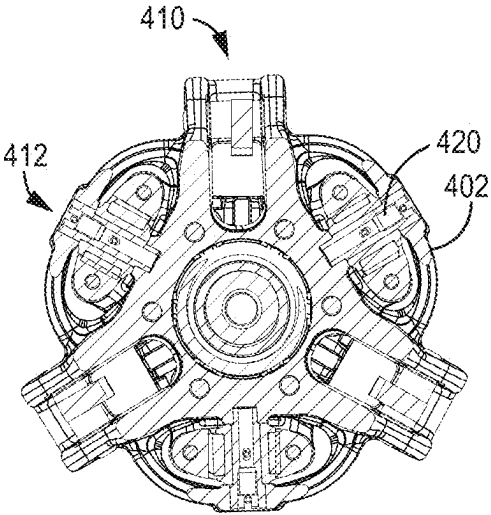

FIG. 16H



SECTION E-E

FIG. 16I

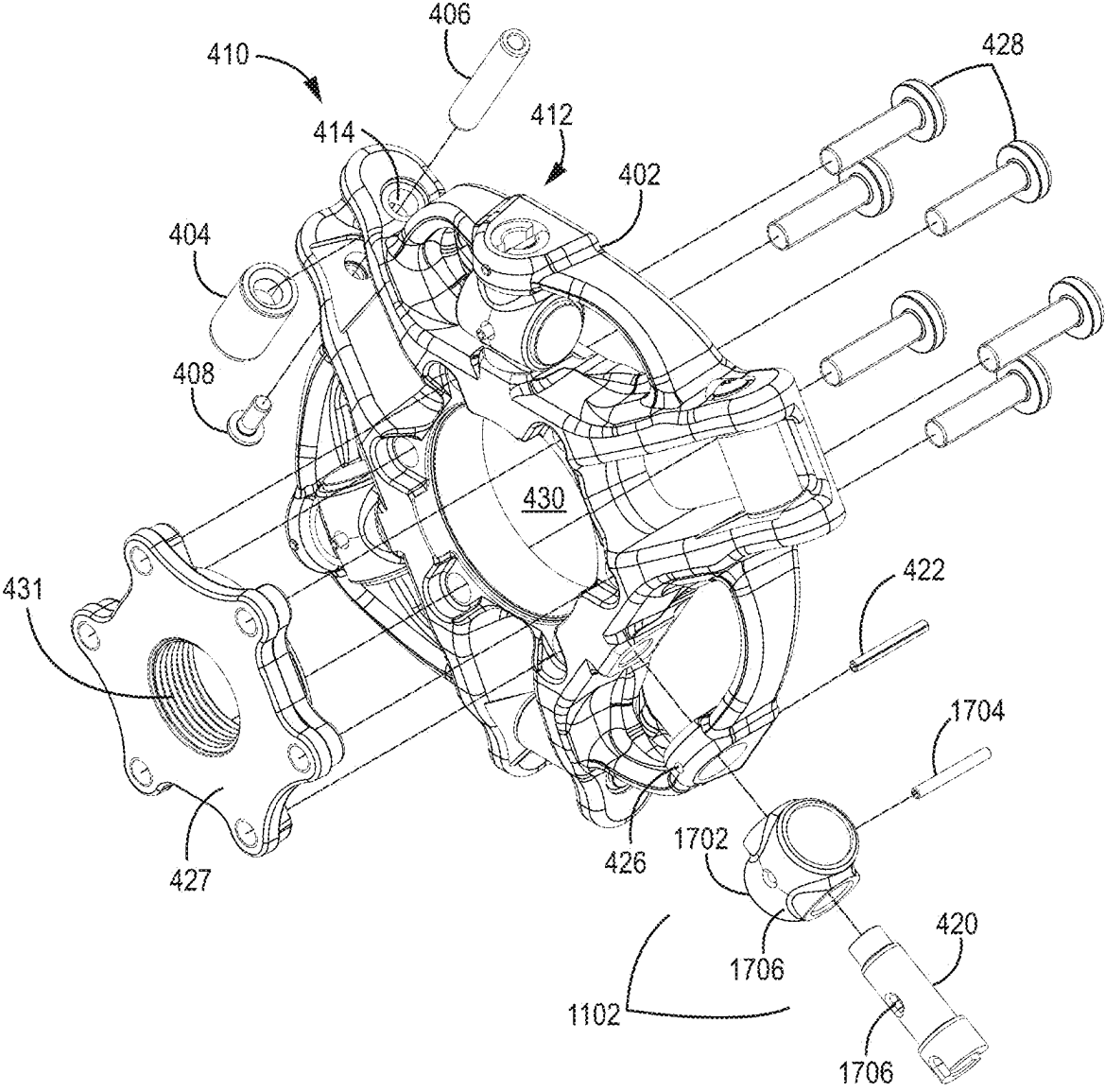
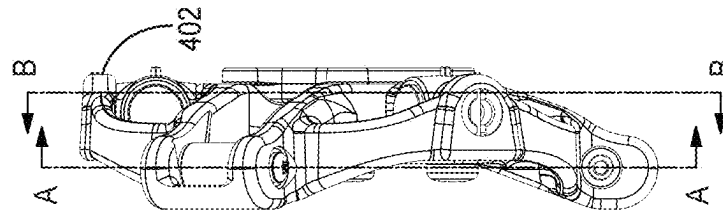
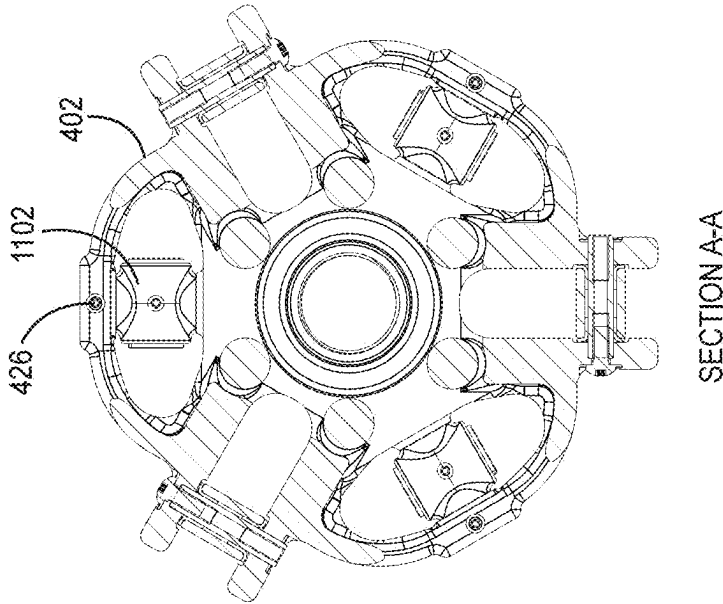
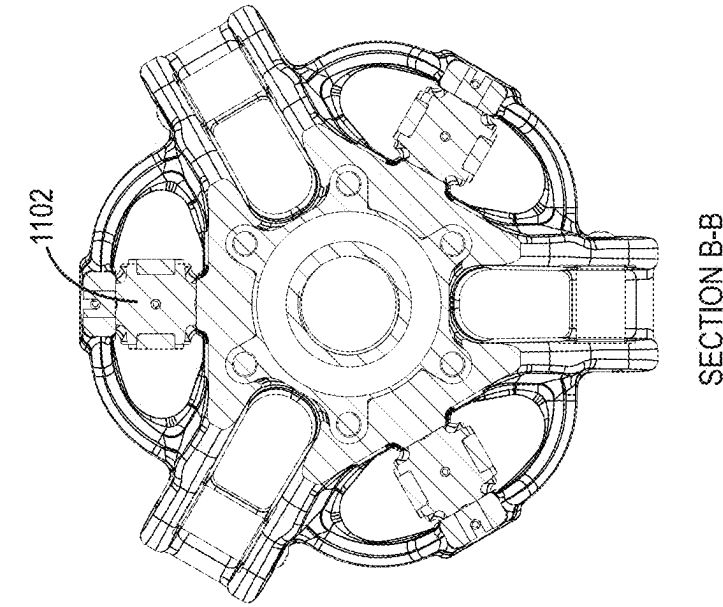

FIG. 17A



SECTION B-B

SECTION A-A

FIG. 17D

FIG. 17C

FIG. 17B

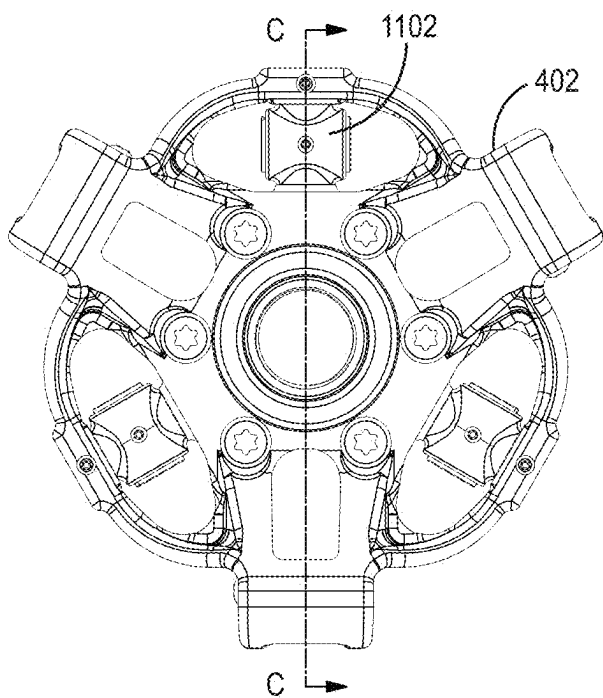
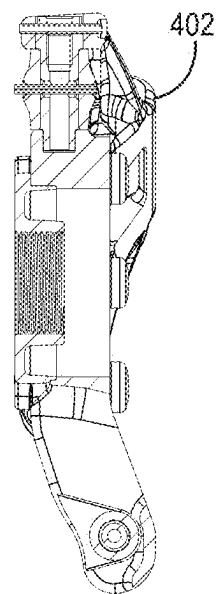

FIG. 17E



SECTION C-C

FIG. 17F

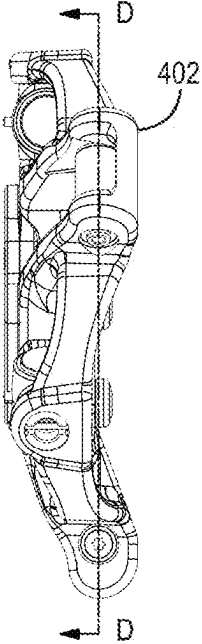
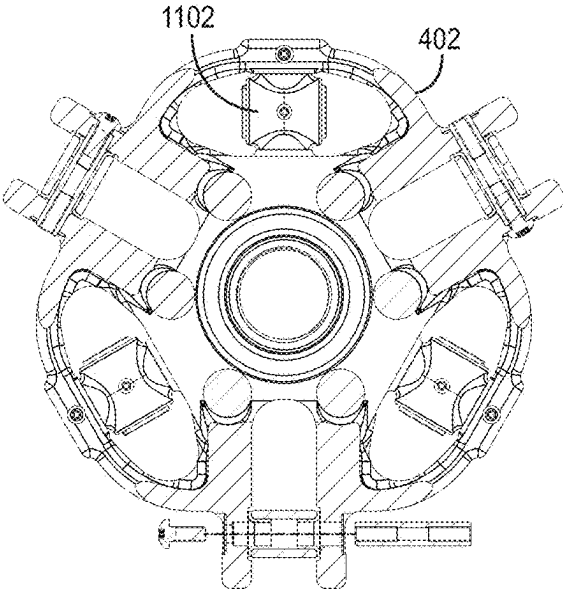

FIG. 17G



SECTION D-D

FIG. 17H

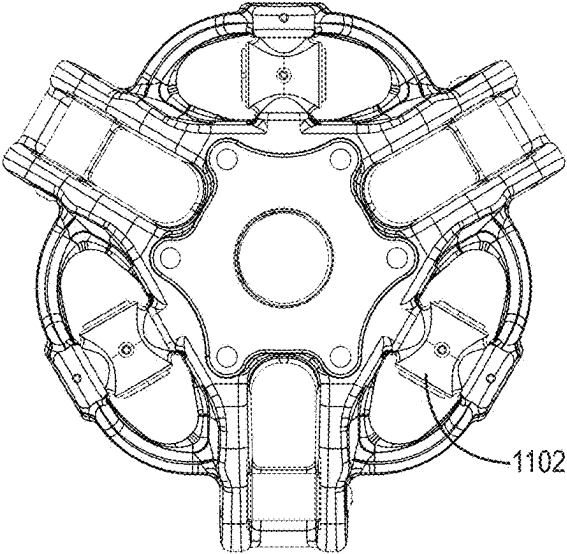

FIG. 17I

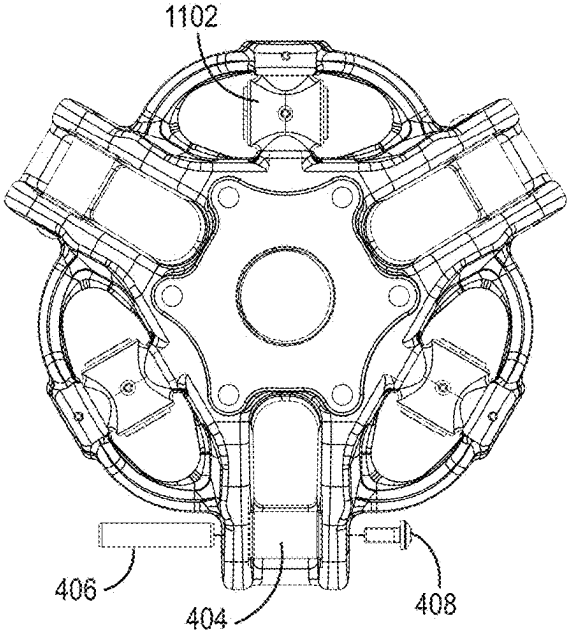

FIG. 17J

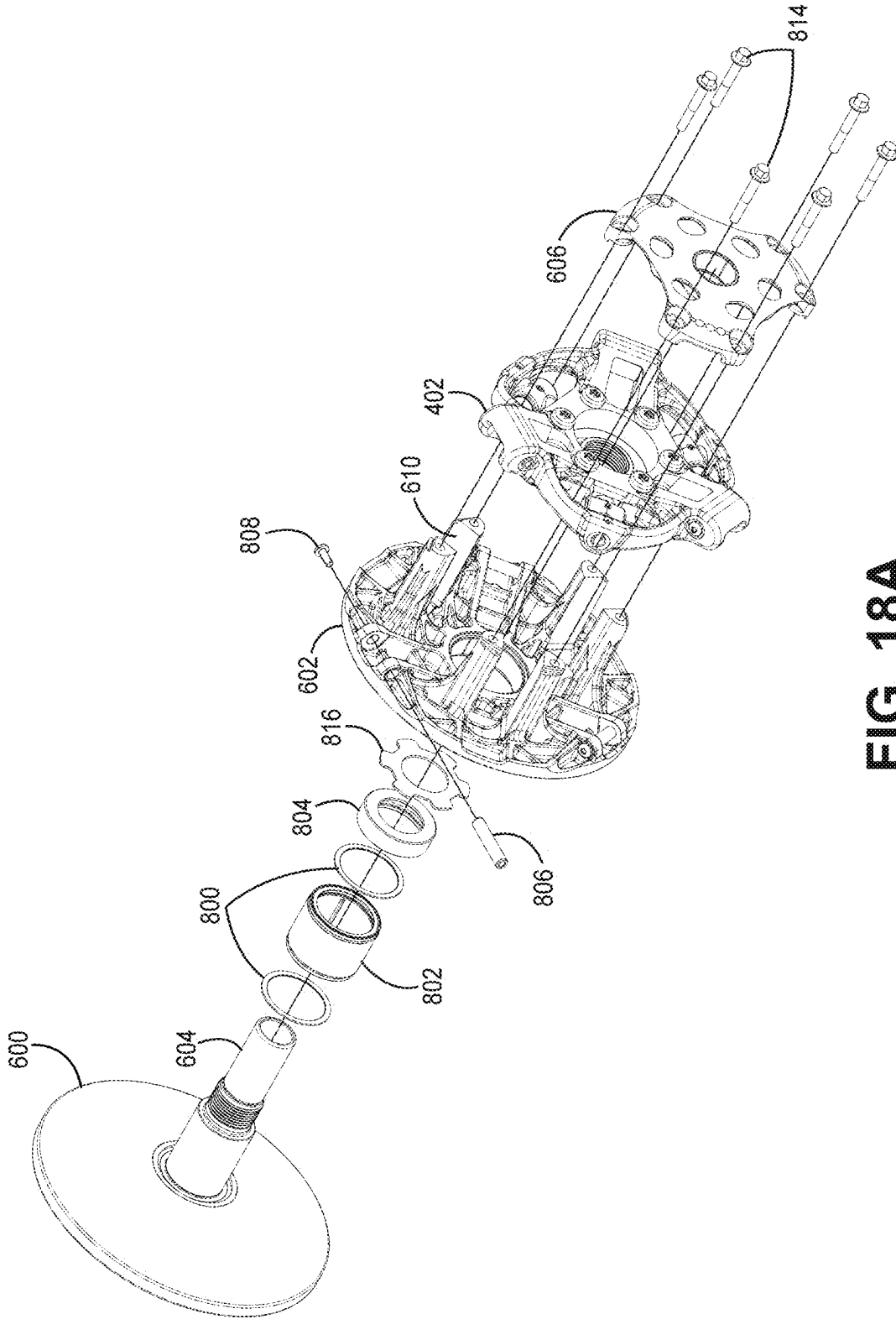

FIG. 18A

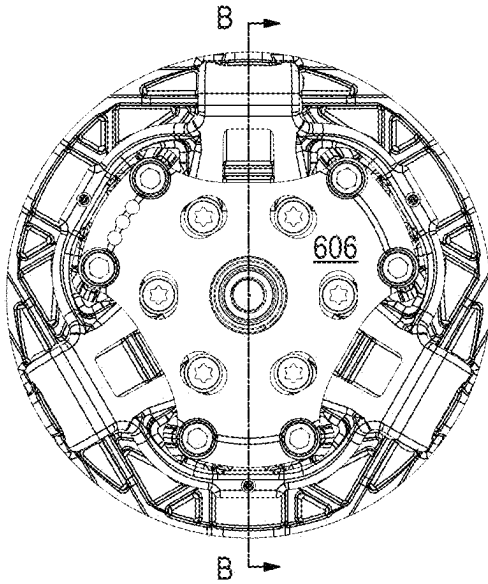
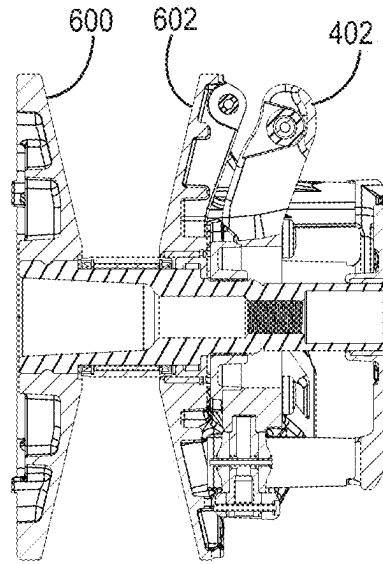

FIG. 18B



SECTION B-B

FIG. 18C

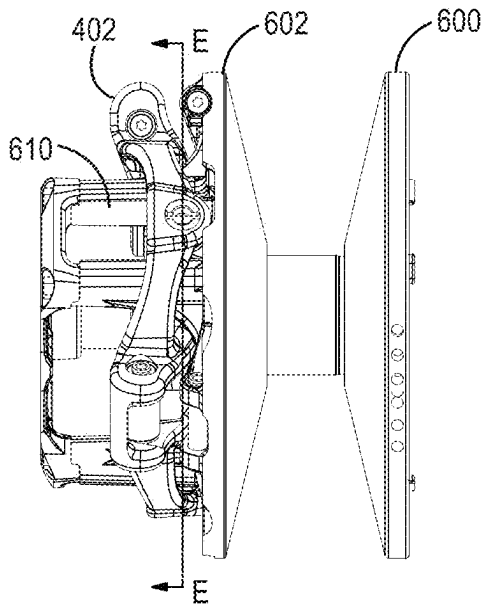
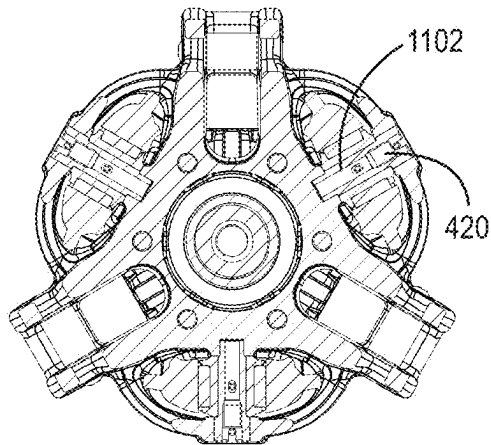

FIG. 18D



SECTION E-E

FIG. 18E

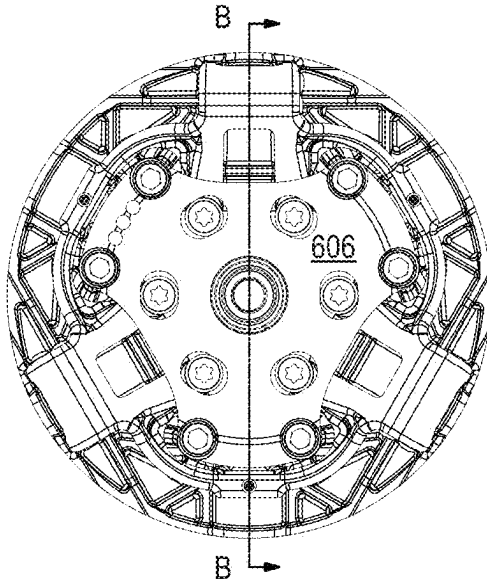

FIG. 19A

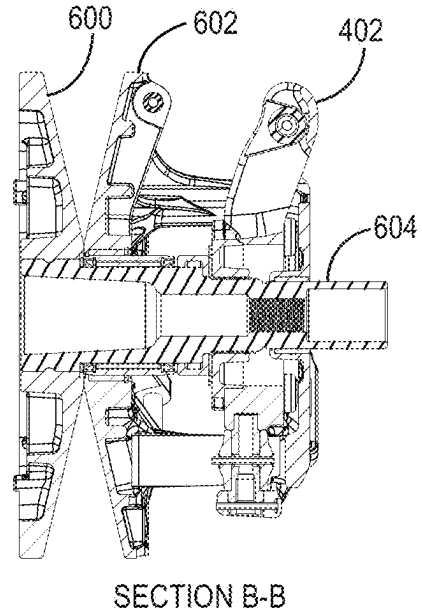

FIG. 19B

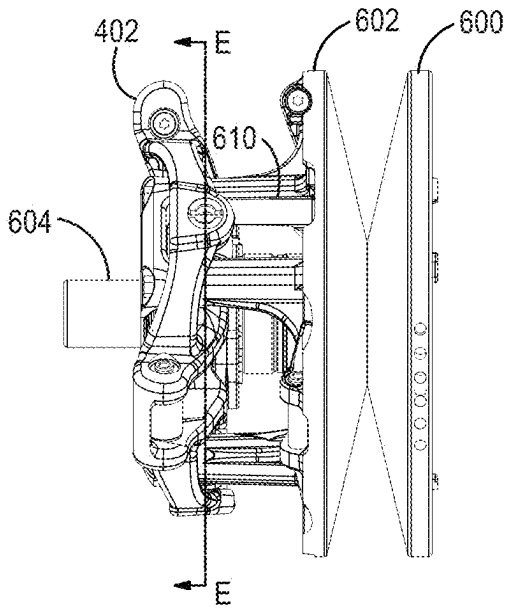

FIG. 19C

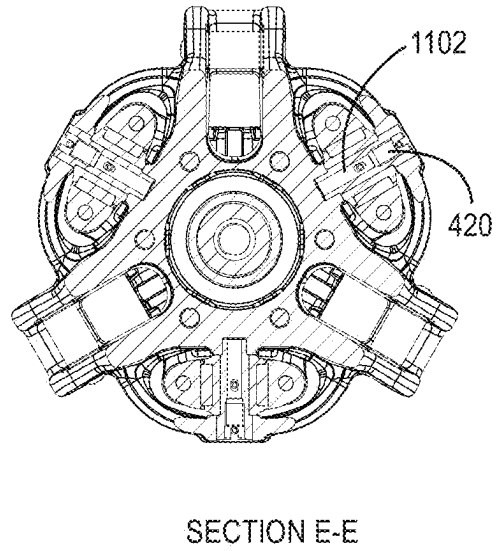

FIG. 19D

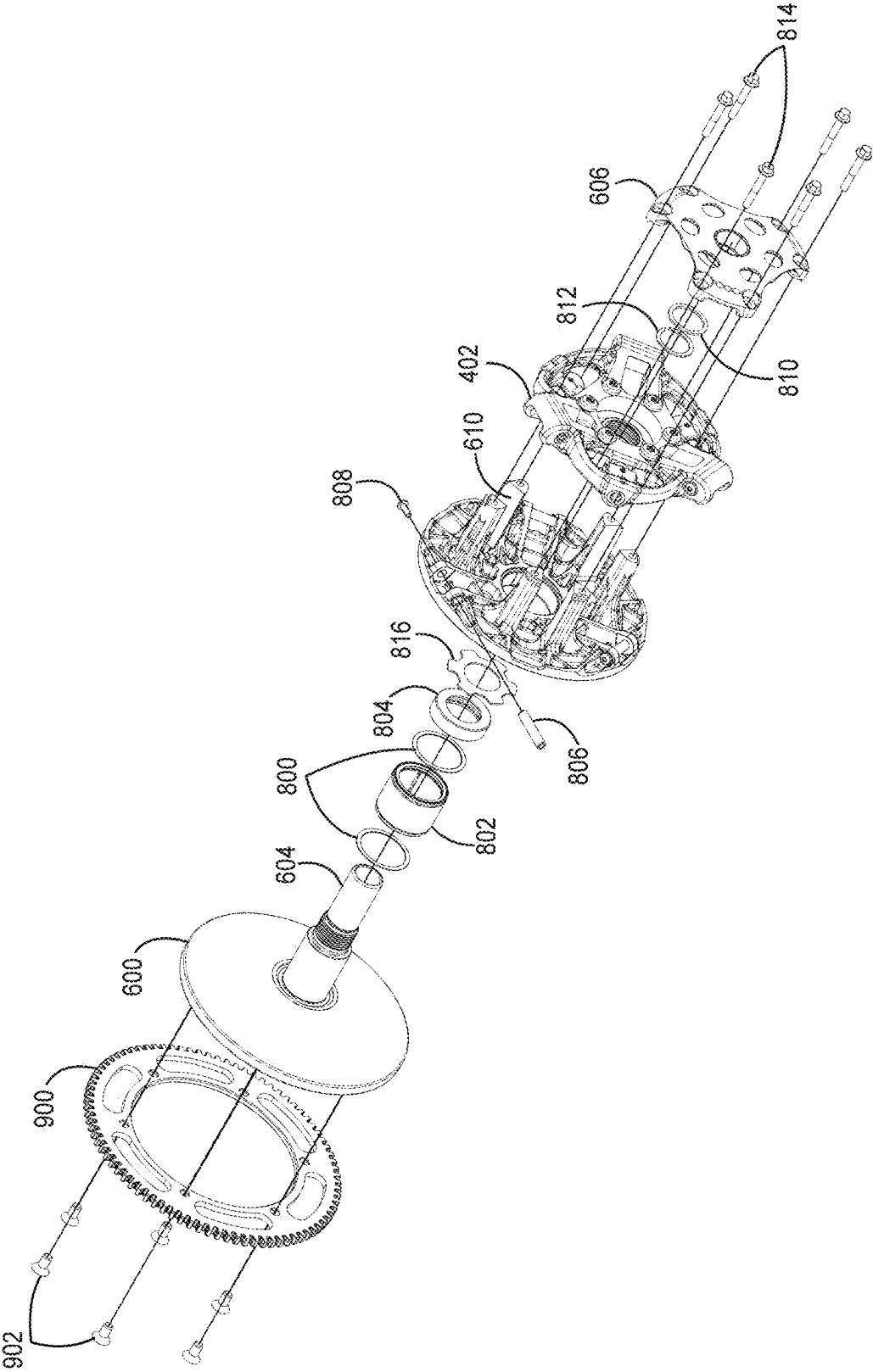

FIG. 20A

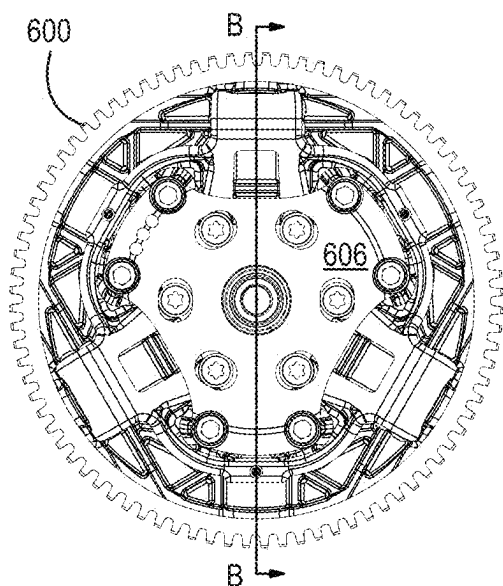
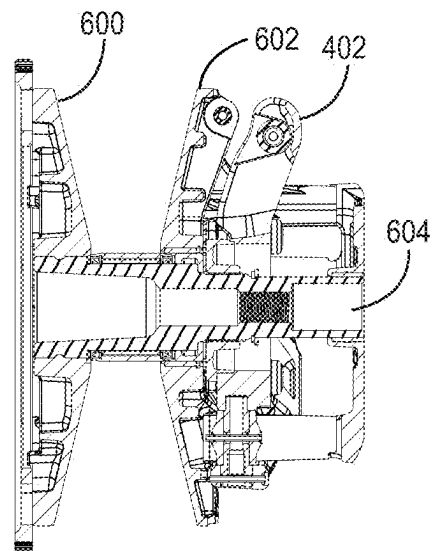

FIG. 20B



SECTION B-B

FIG. 20C

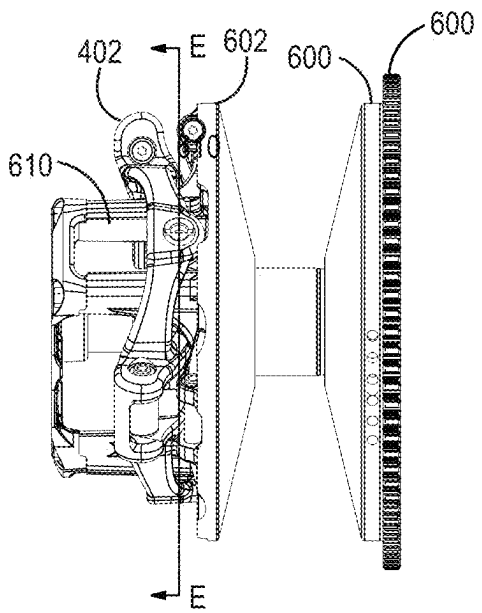
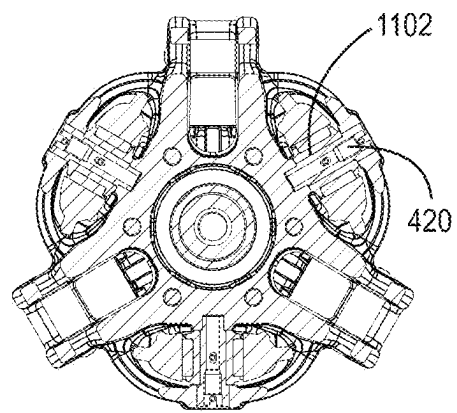

FIG. 20D



SECTION E-E

FIG. 20E

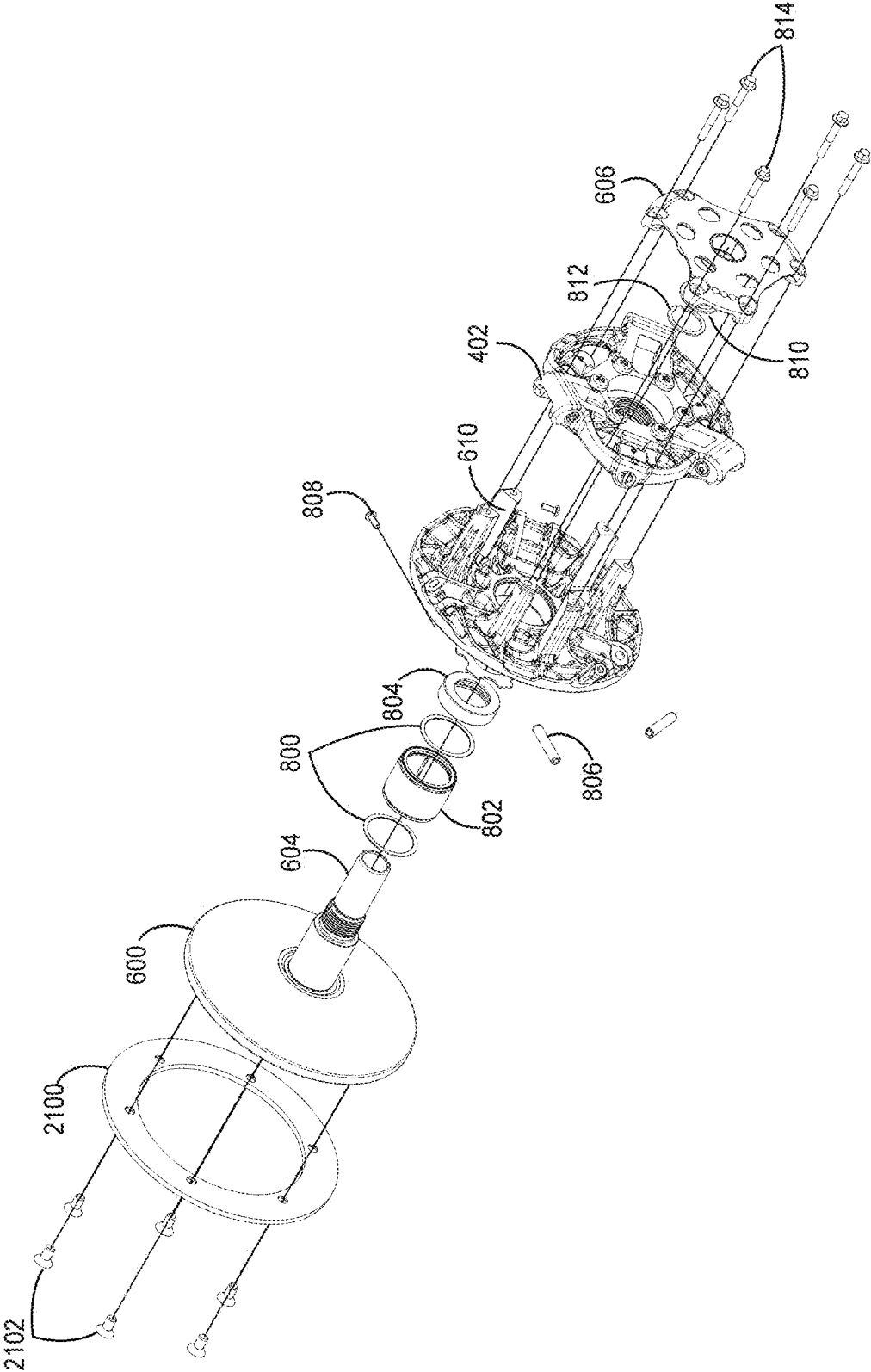

FIG. 21A

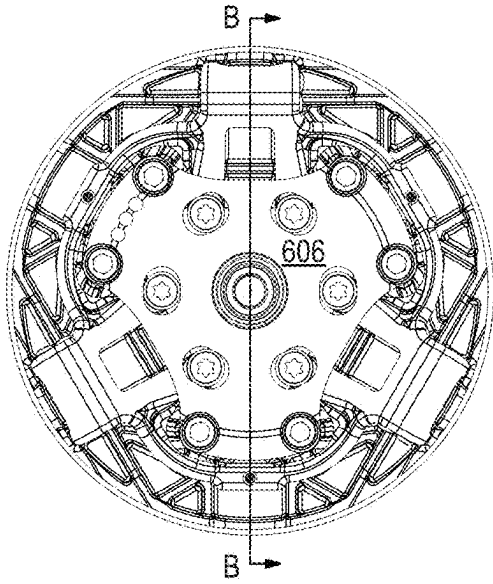
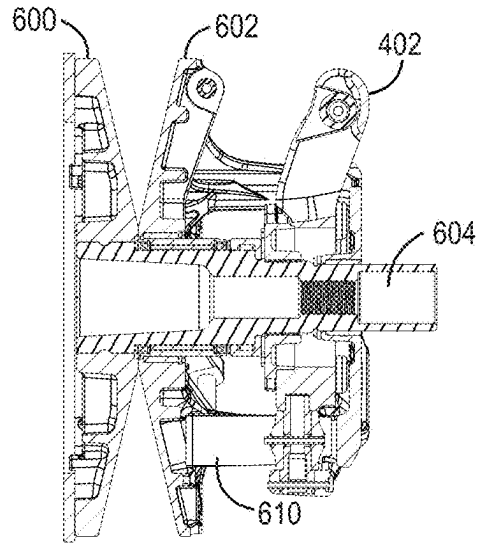
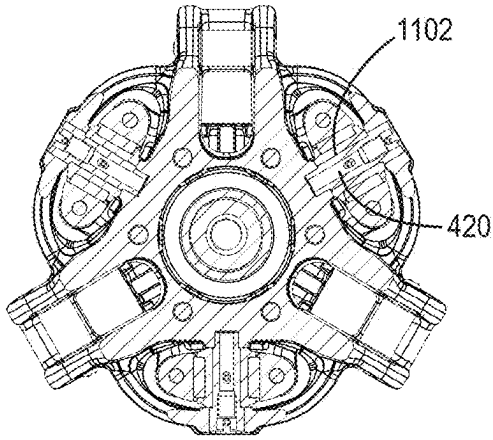

FIG. 21B



SECTION B-B

FIG. 21C



SECTION E-E

FIG. 21D

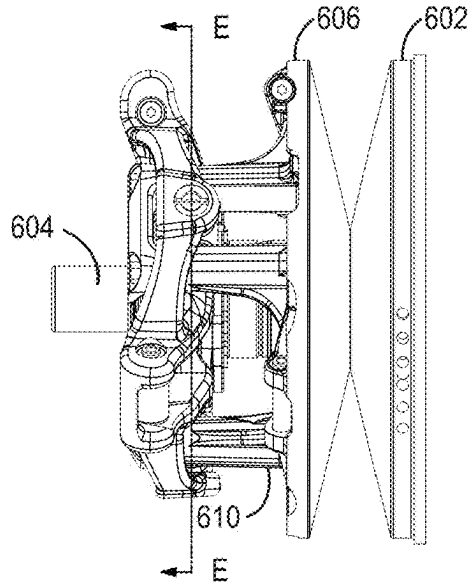

FIG. 21E

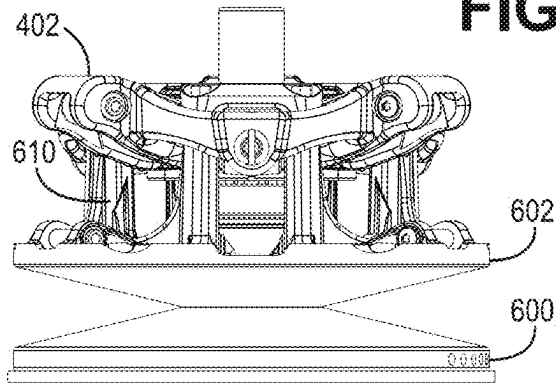

FIG. 21F

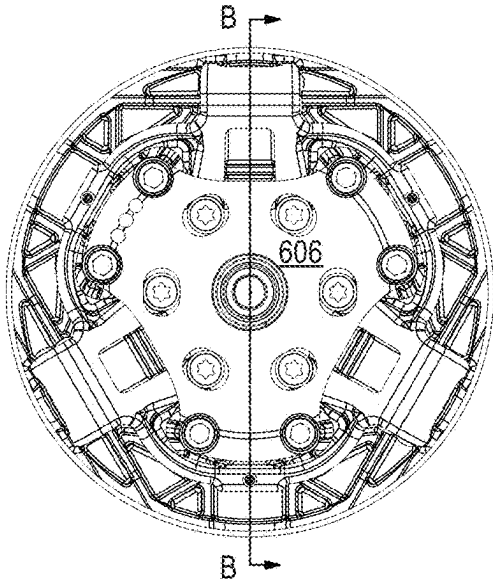
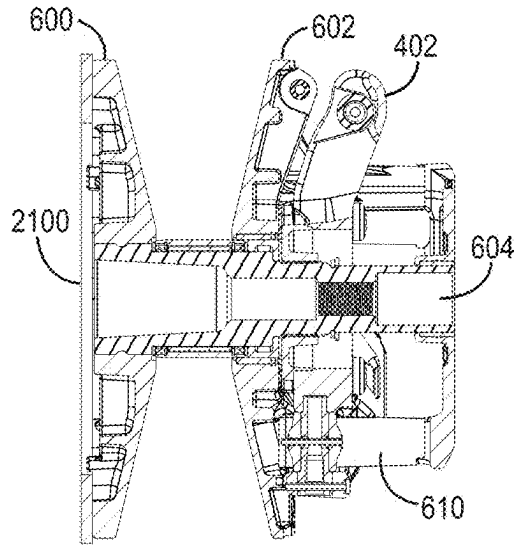

FIG. 22A



SECTION B-B

FIG. 22B

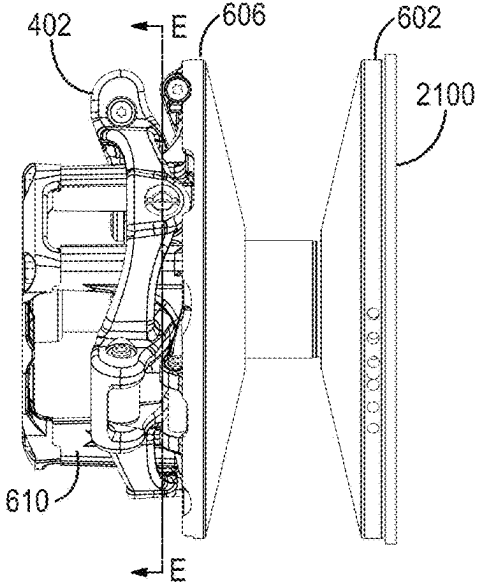
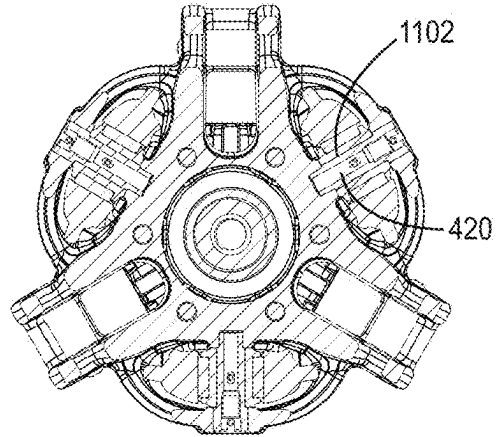

FIG. 22C



SECTION E-E

FIG. 22D

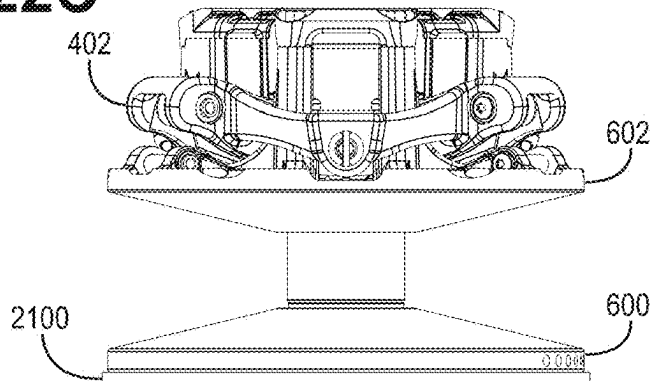

FIG. 22E

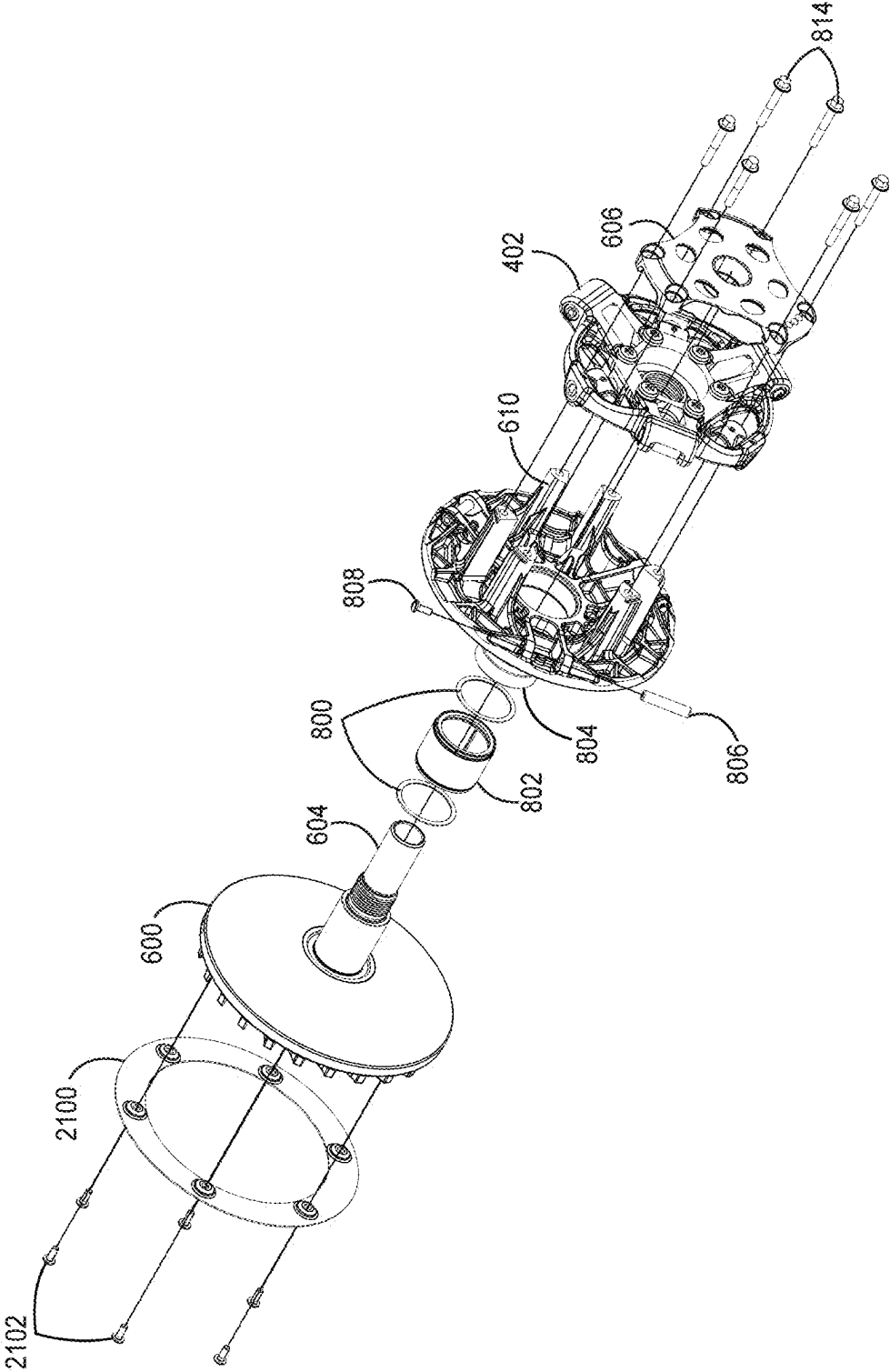

FIG. 23A

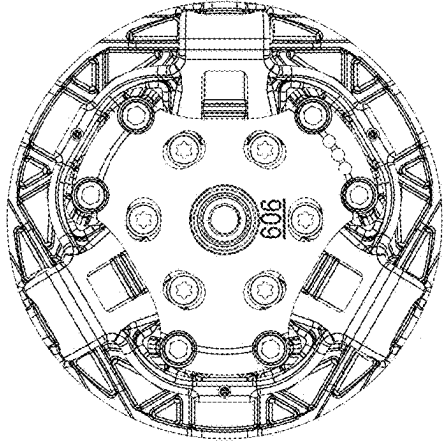

FIG. 23D

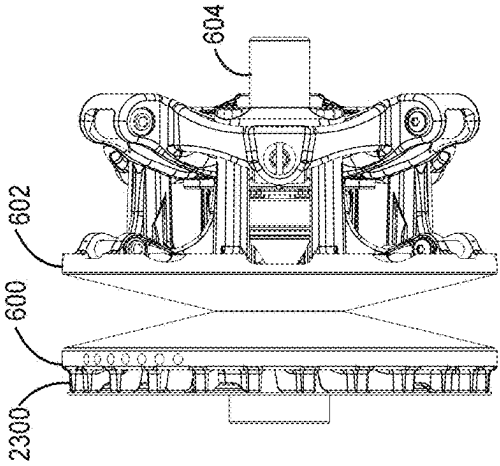

FIG. 23C

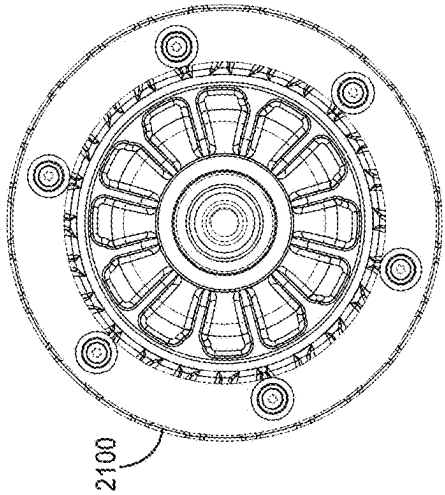
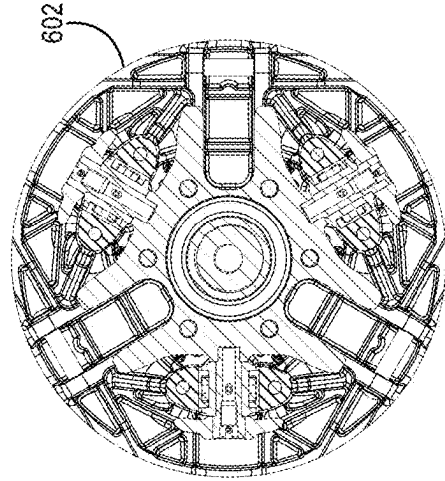

FIG. 23B



SECTION B-B
FIG. 23F

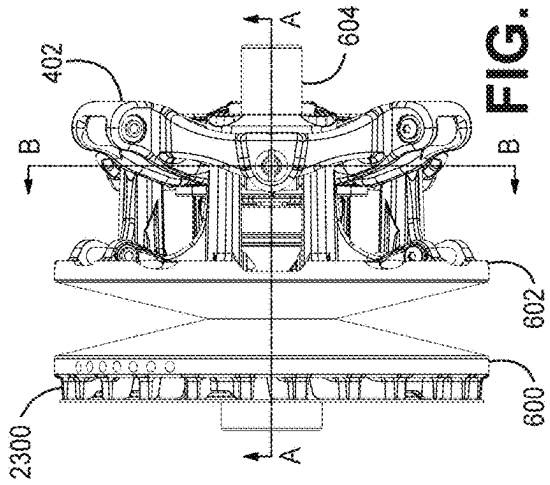

FIG. 23E

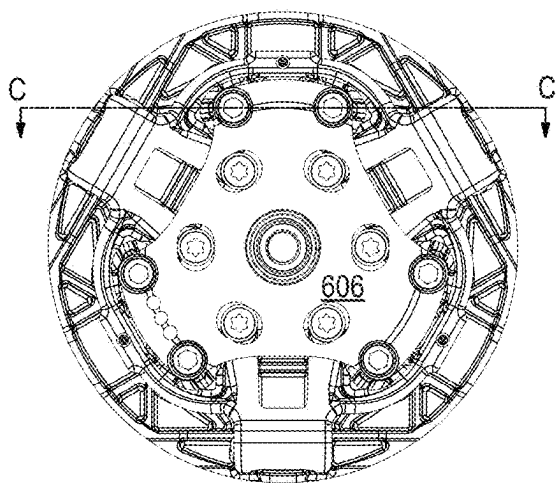

FIG. 23G

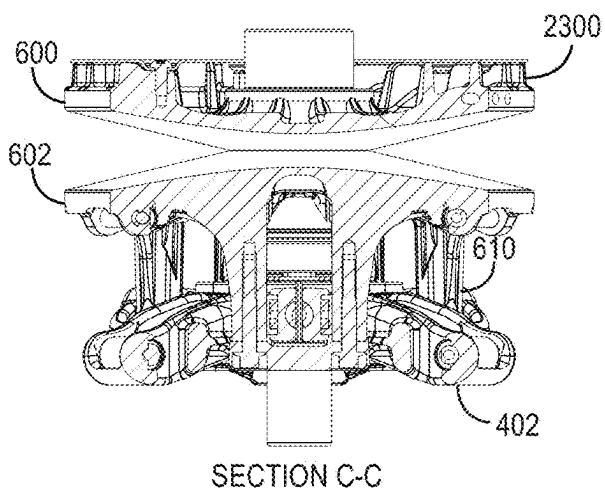

FIG. 23H

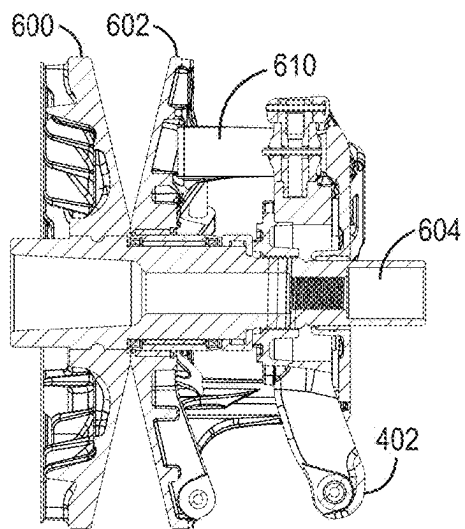

FIG. 23I

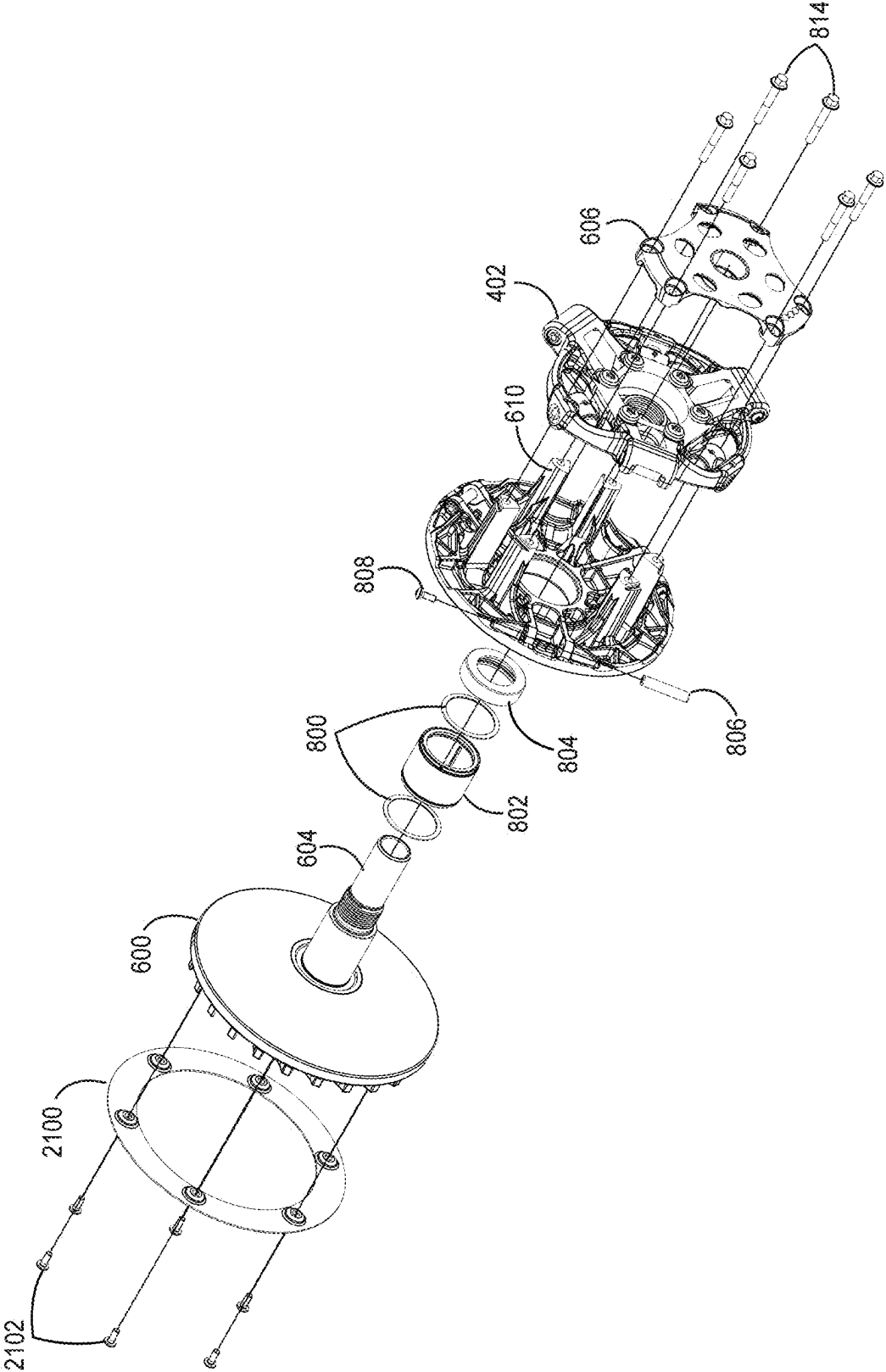

FIG. 24A

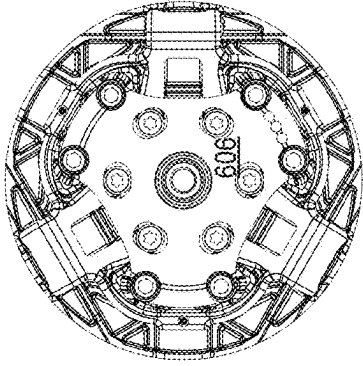

FIG. 24D

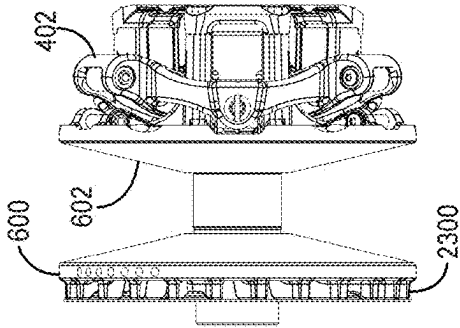

FIG. 24C

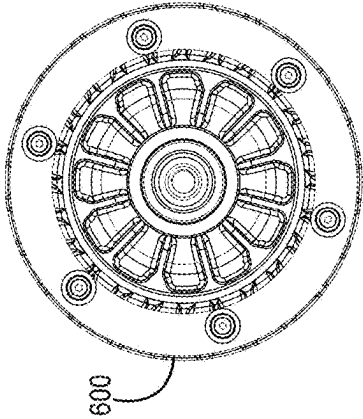

FIG. 24B

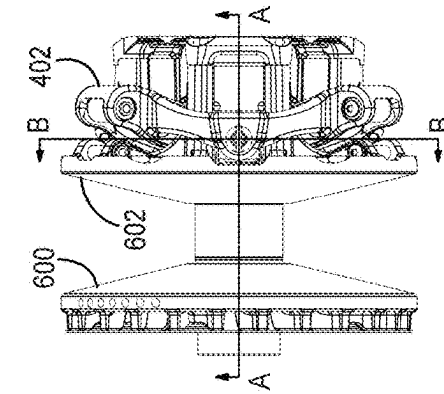

FIG. 24E

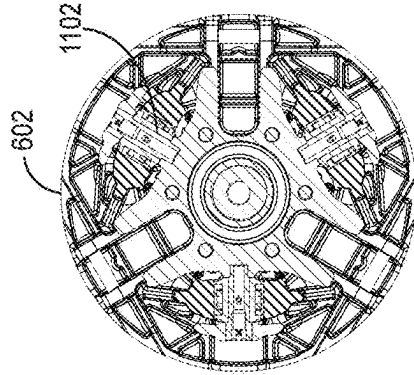
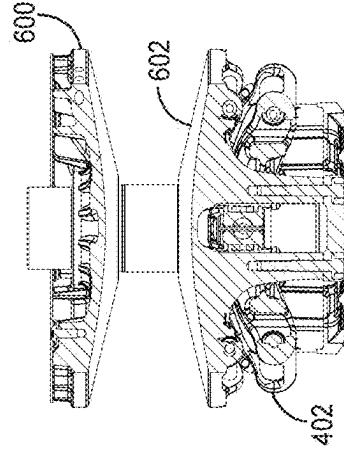

FIG. 24F



SECTION C-C
FIG. 24G

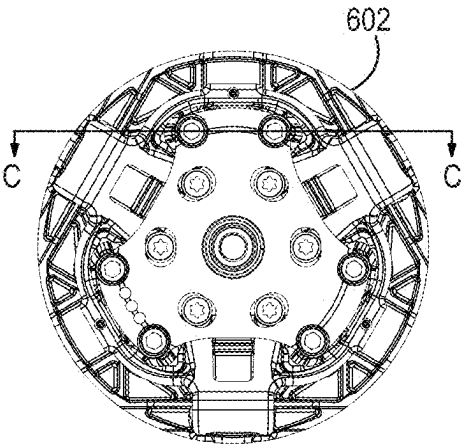
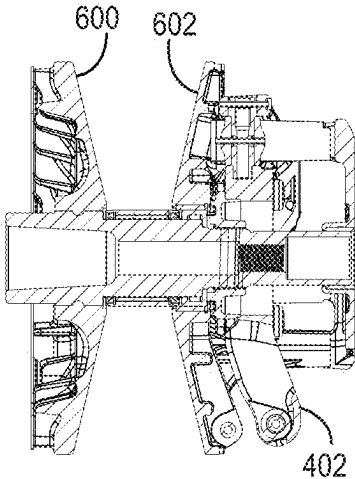

FIG. 24H



SECTION A-A

FIG. 24I

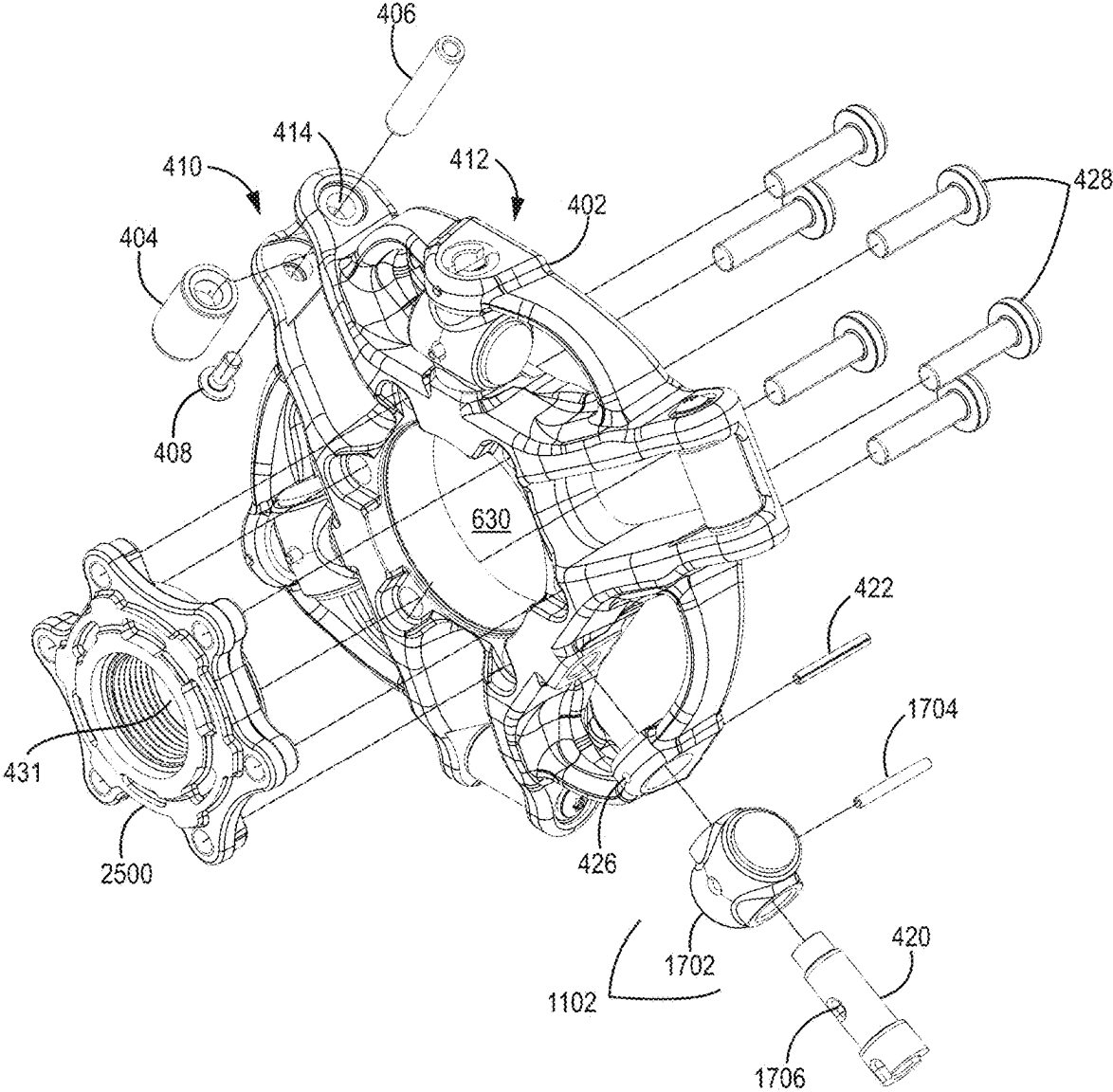

FIG. 25

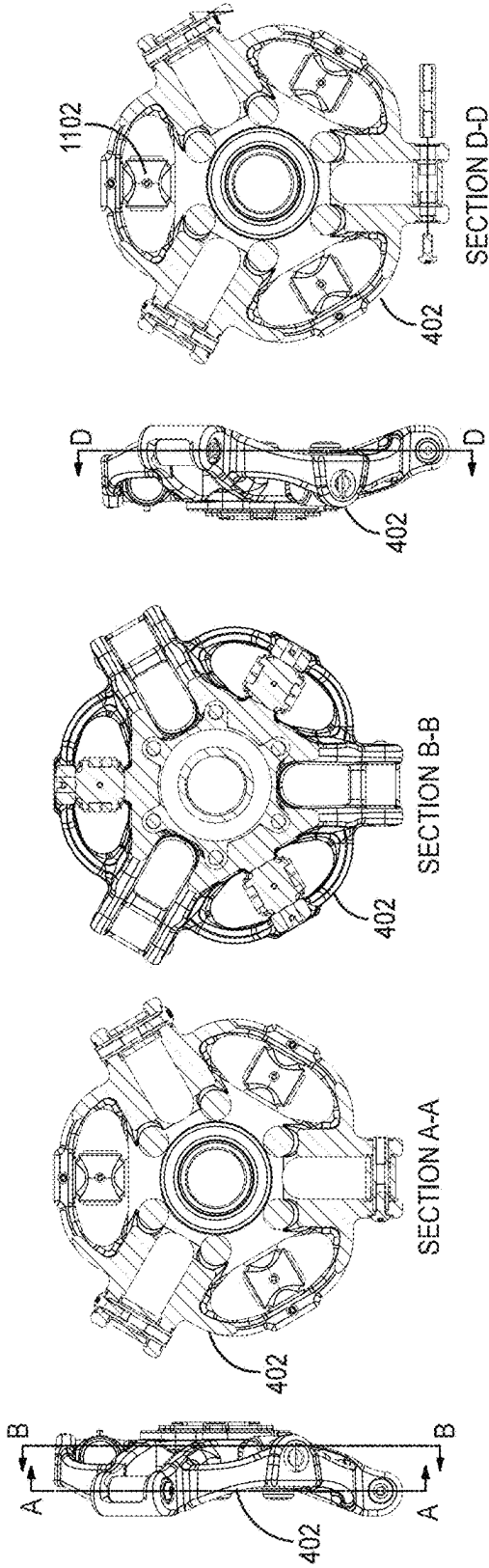

FIG. 26A **FIG. 26B** **FIG. 26C** **FIG. 26D** **FIG. 26E**

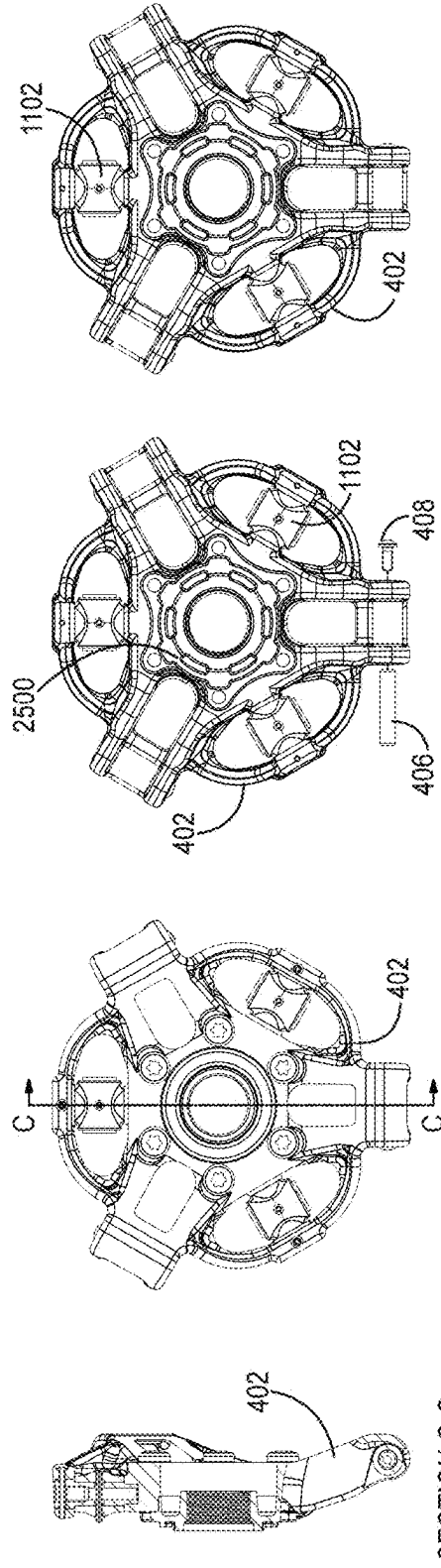

FIG. 26F **FIG. 26G** **FIG. 26H** **FIG. 26I**

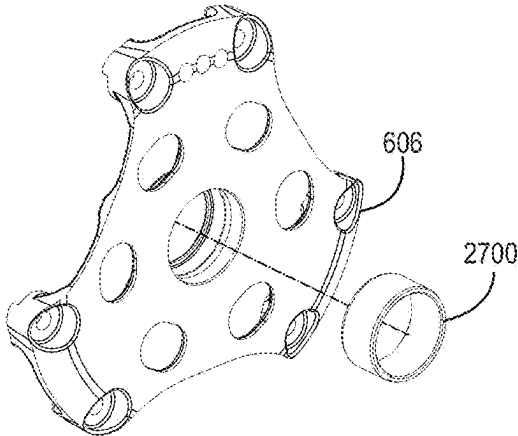

FIG. 27A

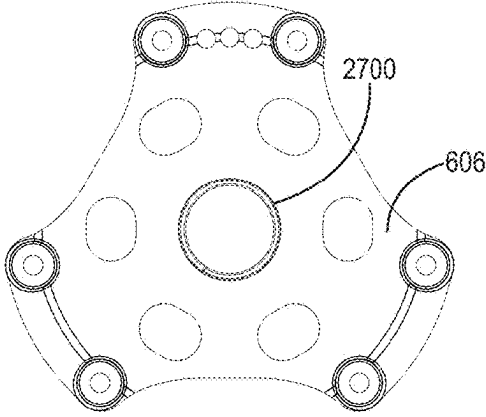

FIG. 27B

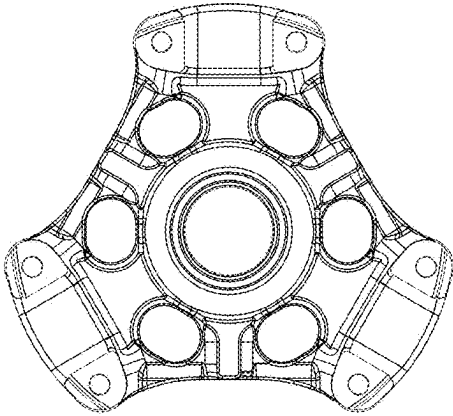

FIG. 27C

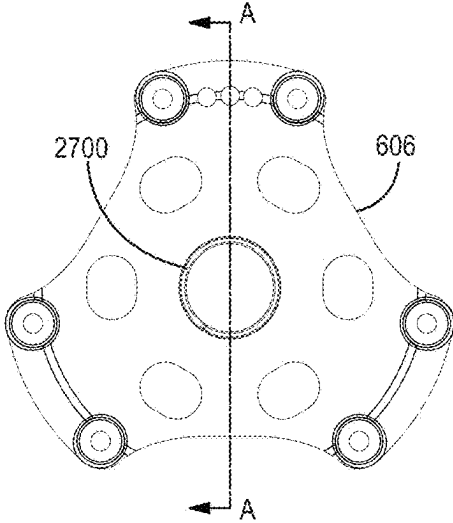
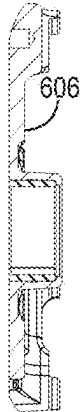

FIG. 27D



SECTION A-A
FIG. 27E

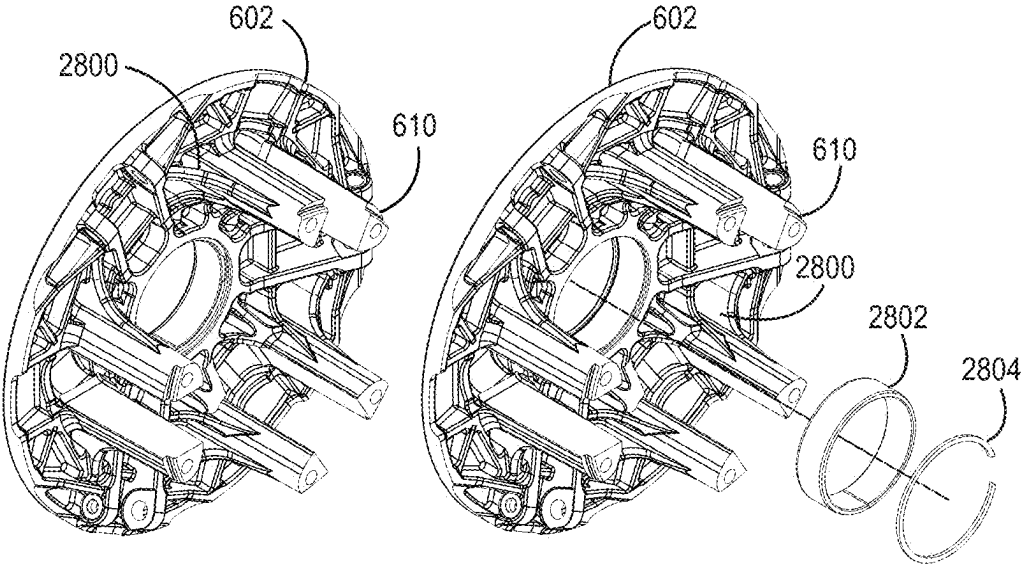

FIG. 28A

FIG. 28B

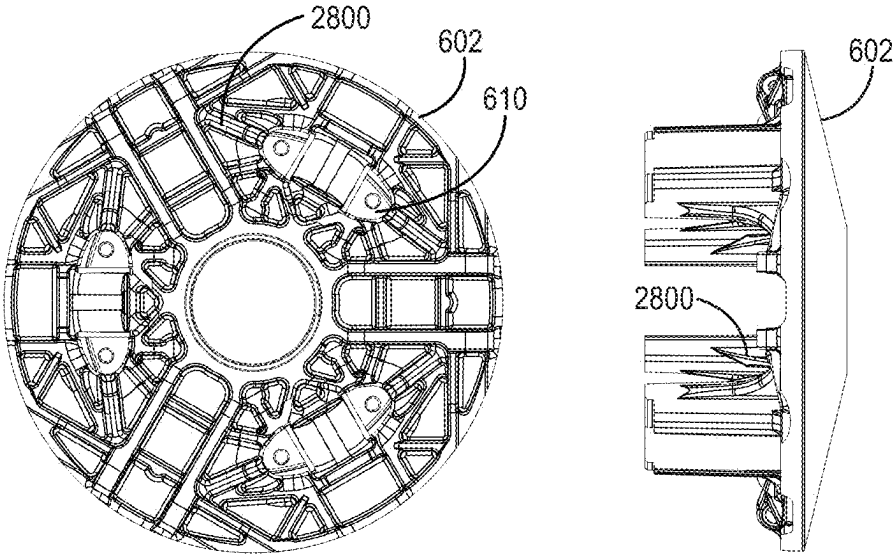

FIG. 28C

FIG. 28D

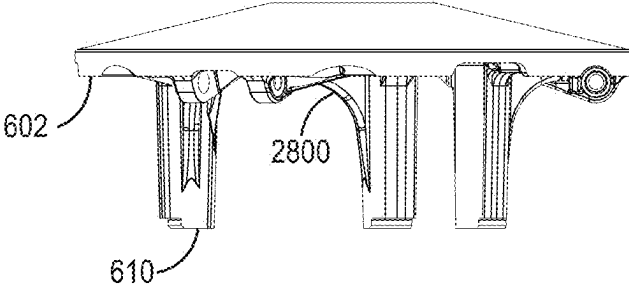

FIG. 28E

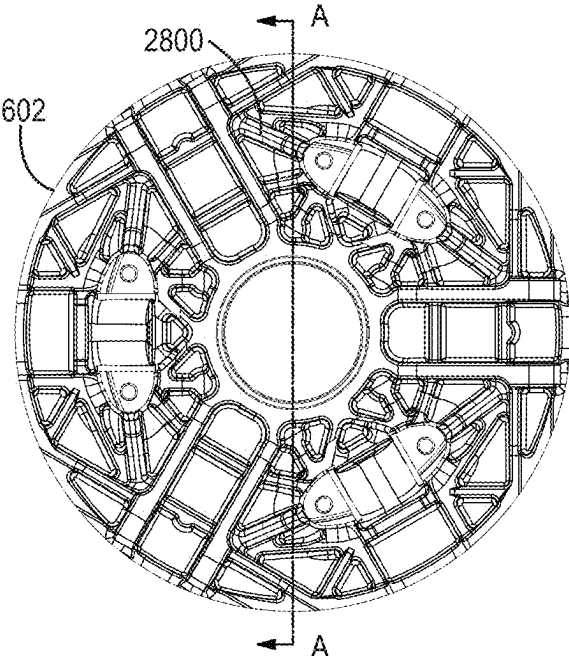
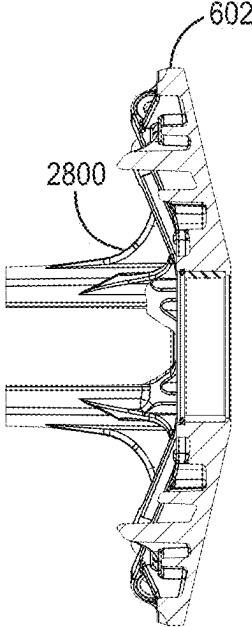

FIG. 28F



SECTION A-A

FIG. 28G

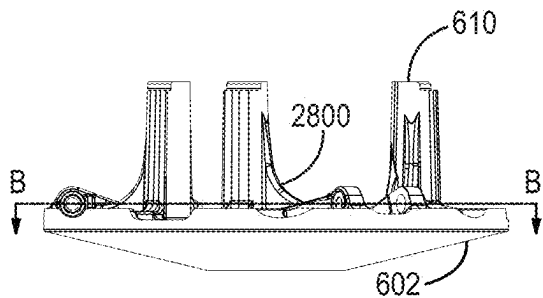
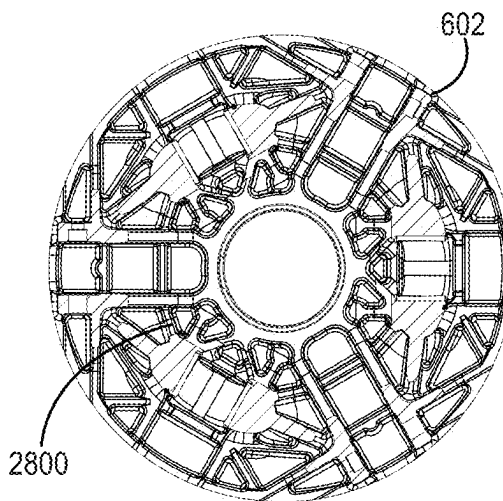

FIG. 28H



SECTION B-B

FIG. 28I

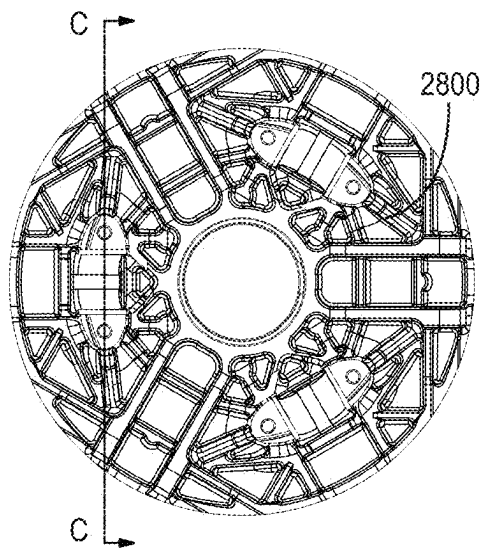
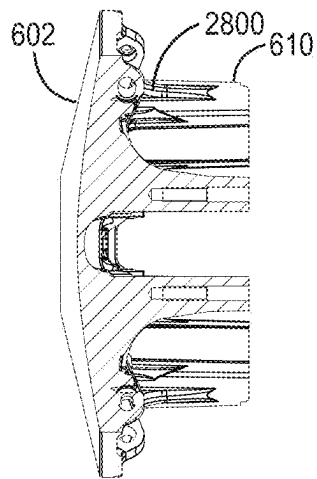

FIG. 28J



SECTION C-C

FIG. 28K

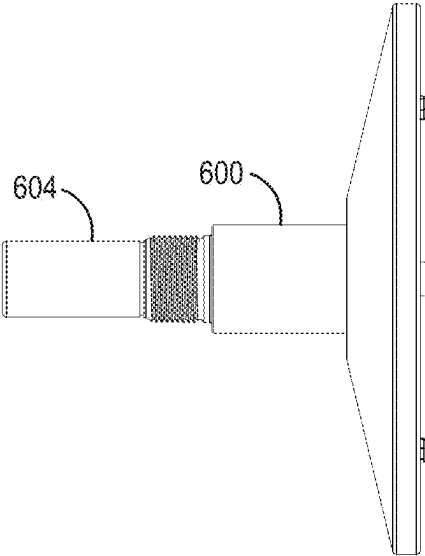

FIG. 29A

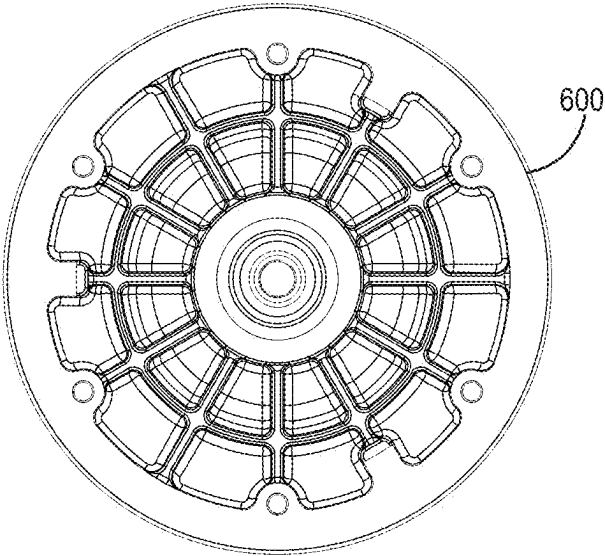

FIG. 29B

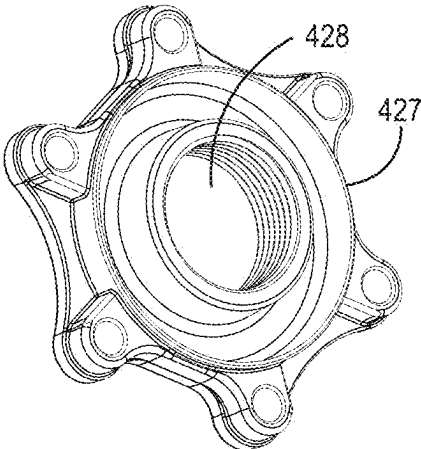

FIG. 30A

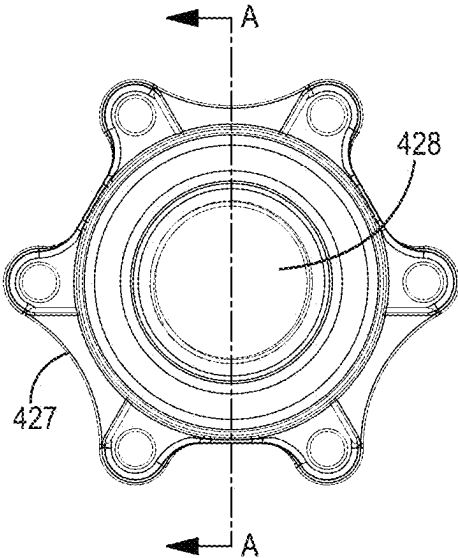

FIG. 30B

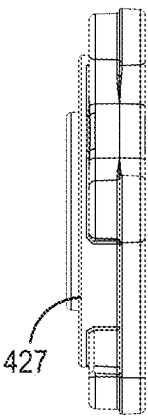

FIG. 30C

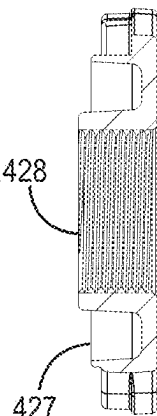

FIG. 30D

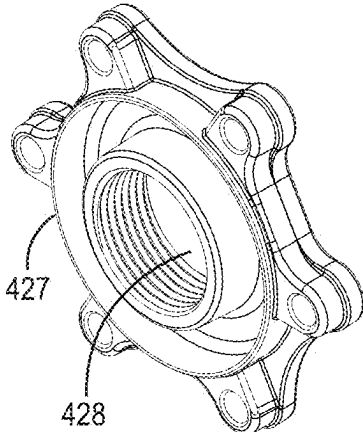

FIG. 30E

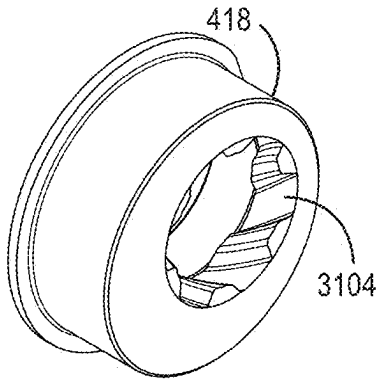

FIG. 31A

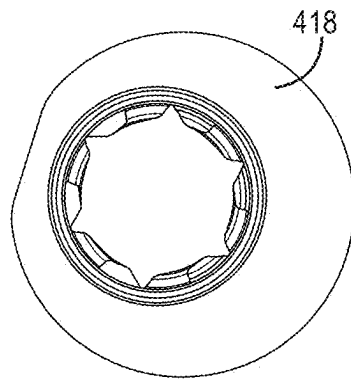

FIG. 31B

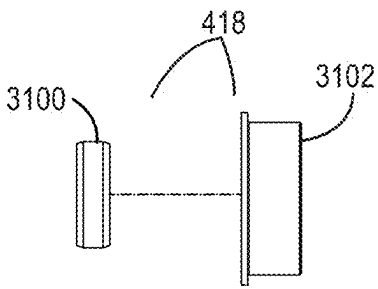

FIG. 31C

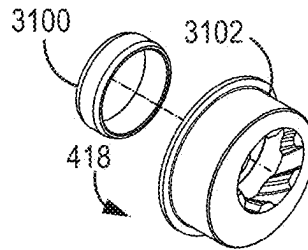

FIG. 31D

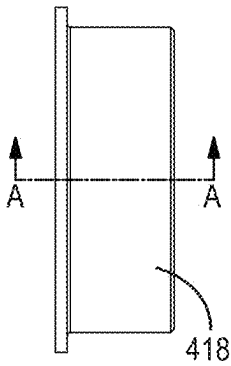

FIG. 31E

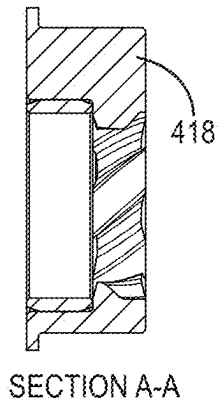

FIG. 31F

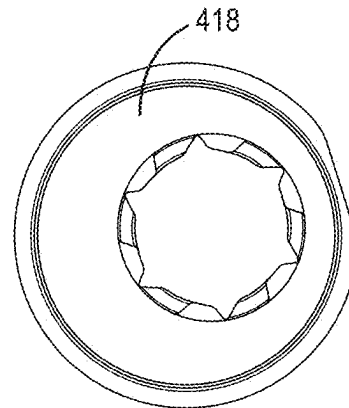

FIG. 31G

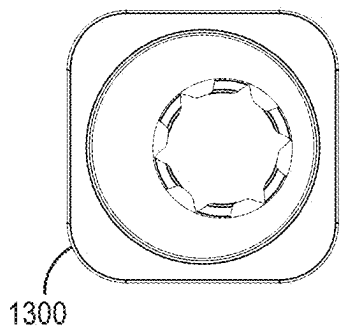

FIG. 32A

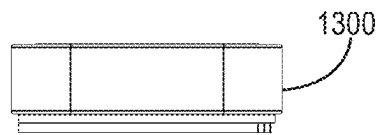

FIG. 32B

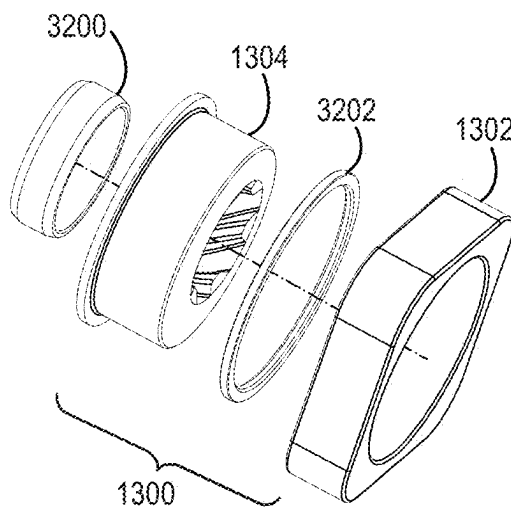

FIG. 32C

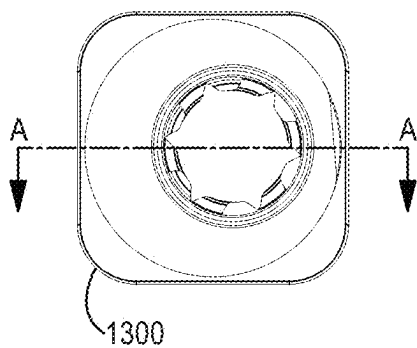
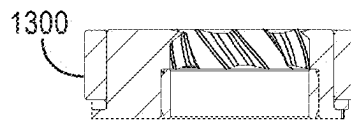

FIG. 32D



SECTION A-A
FIG. 32E

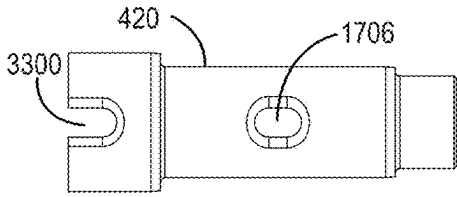

FIG. 33A

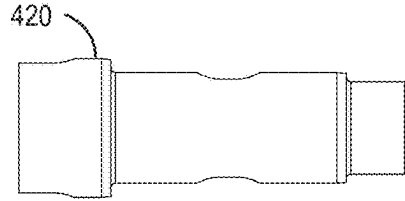

FIG. 33B

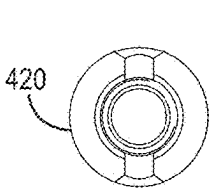

FIG. 33C

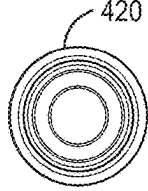

FIG. 33D

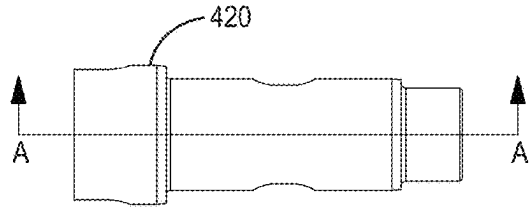

FIG. 33E

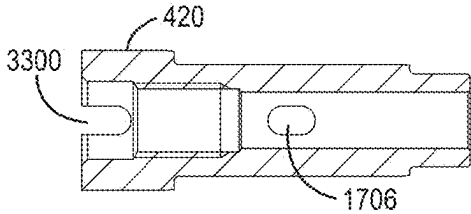

FIG. 33F

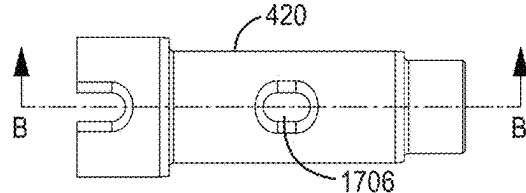
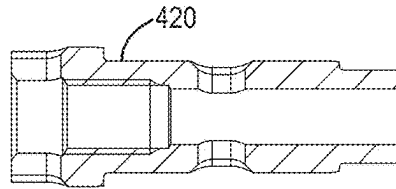

FIG. 33G



SECTION B-B

FIG. 33H

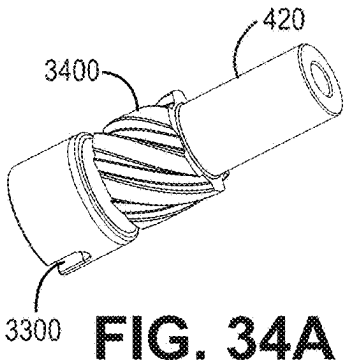

FIG. 34A

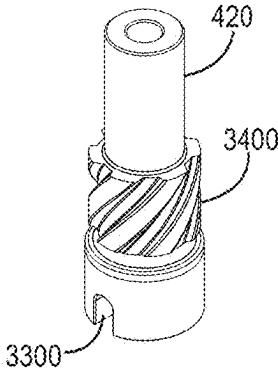

FIG. 34B

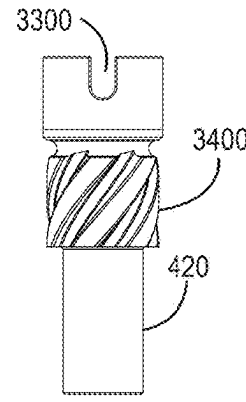

FIG. 34C

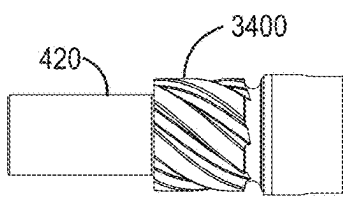

FIG. 34D

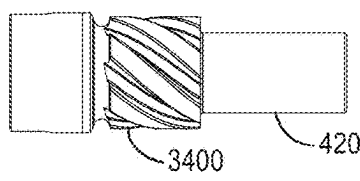

FIG. 34E

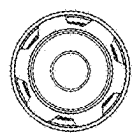

FIG. 34F

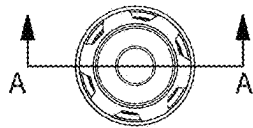
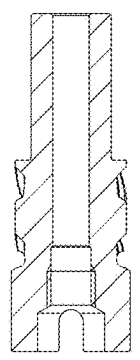

FIG. 34G



SECTION A-A

FIG. 34H

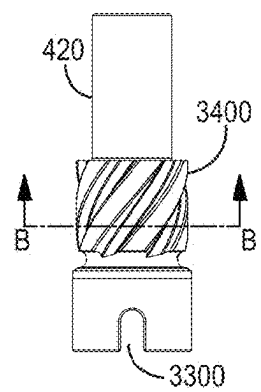
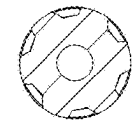

FIG. 34I



SECTION B-B

FIG. 34J

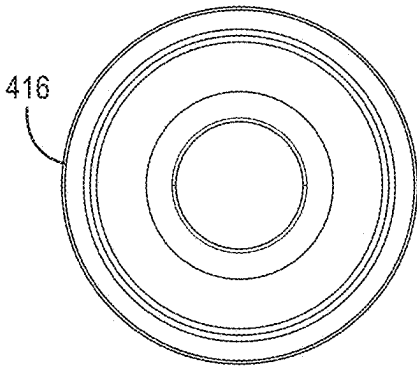

FIG. 35A

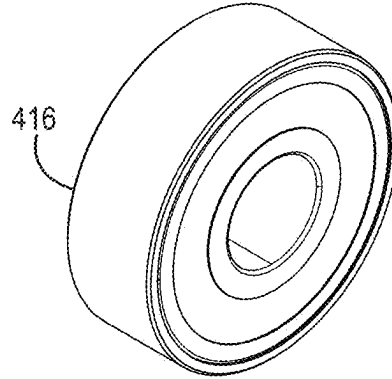

FIG. 35B

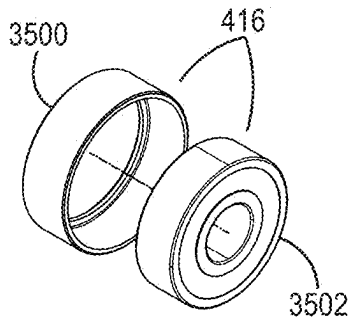

FIG. 35C

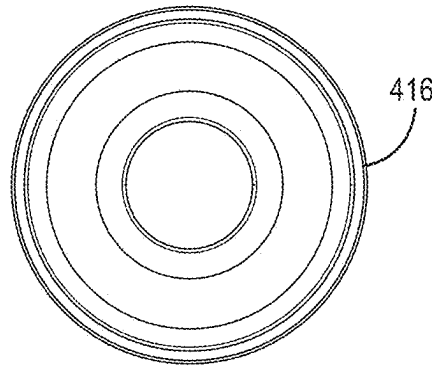

FIG. 35D

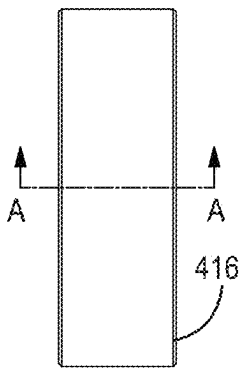
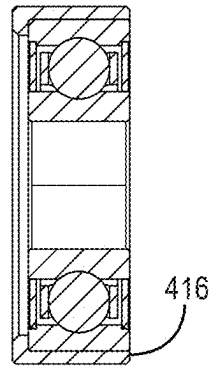

FIG. 35E



SECTION A-A
FIG. 35F

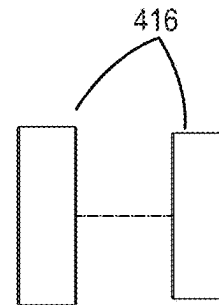

FIG. 35G

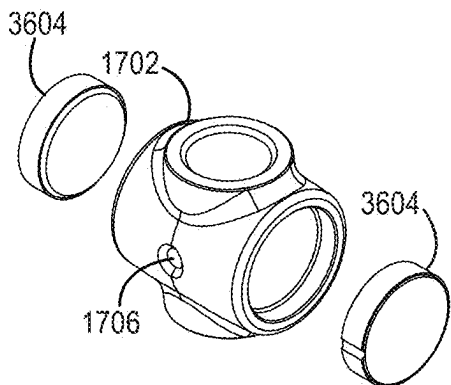

FIG. 36A

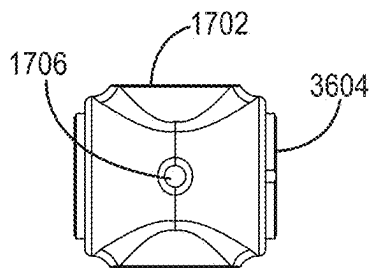

FIG. 36B

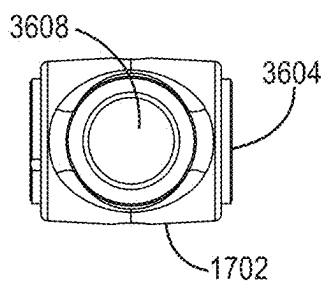

FIG. 36C

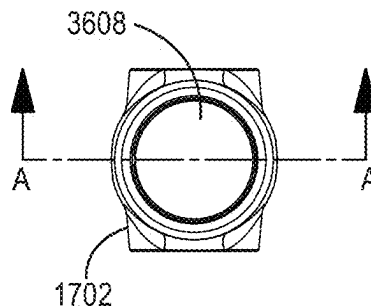

FIG. 36D

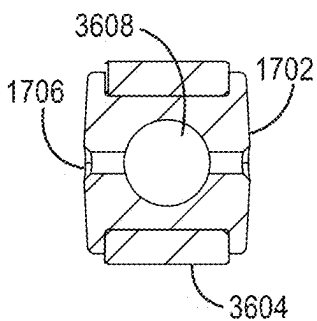

FIG. 36E

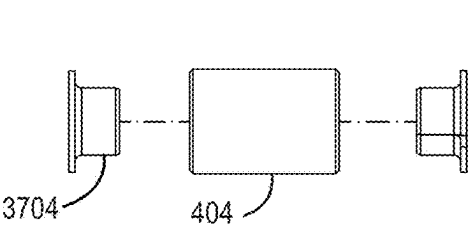

FIG. 37A

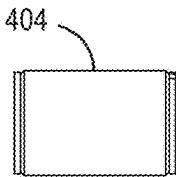

FIG. 37B

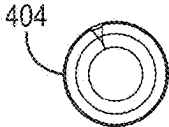

FIG. 37C

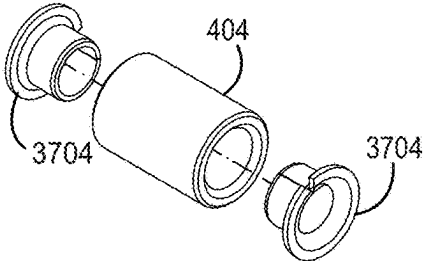

FIG. 37D

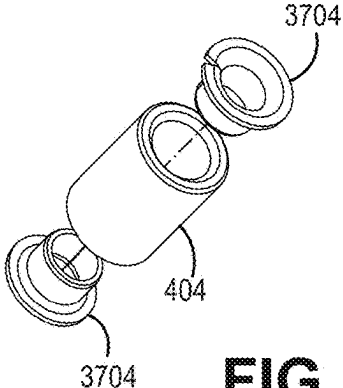

FIG. 37E

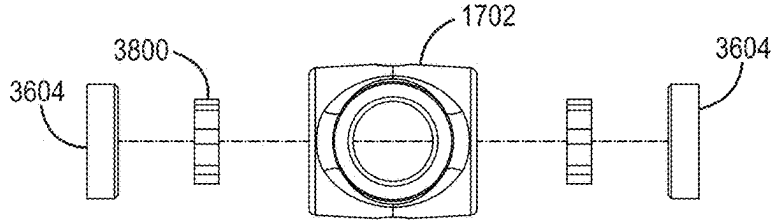

FIG. 38A

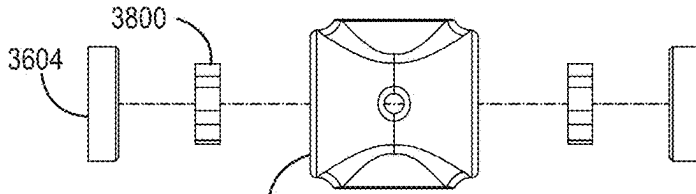

FIG. 38B

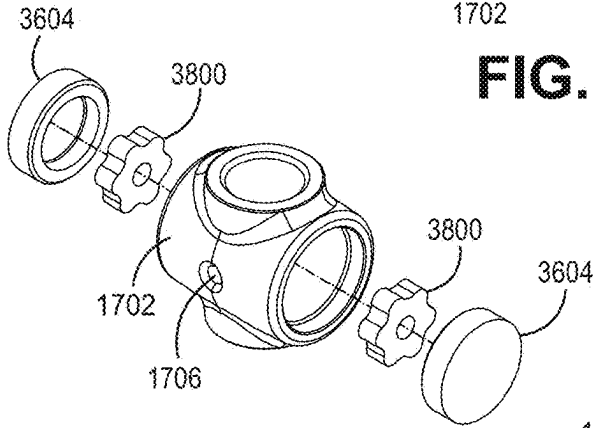

FIG. 38C

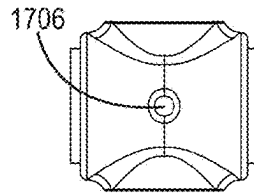

FIG. 38D

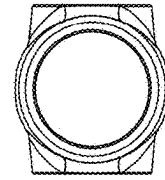

FIG. 38E

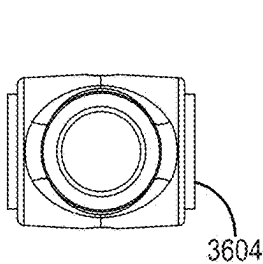

FIG. 38F

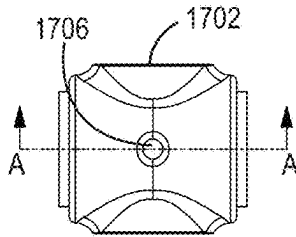
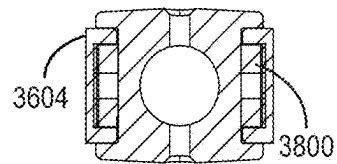

FIG. 38G



SECTION A-A
FIG. 38H

**CONTINUOUSLY VARIABLE
TRANSMISSION FOR RECREATIONAL
VEHICLES AND RELATED COMPONENTS**

[0001] This application is a continuation of U.S. application Ser. No. 18/195,163, filed on May 9, 2023, which is a continuation of U.S. application Ser. No. 16/893,752, filed on Jun. 5, 2020, which claims the benefit of U.S. Provisional Application No. 62/981,090, filed on Feb. 25, 2020, and which applications are incorporated herein by reference. A claim of priority to all, to the extent appropriate, is made.

BACKGROUND

[0002] Snowmobiles are popular land vehicles used as transportation vehicles or as recreational vehicles in cold and snowy conditions. Generally, snowmobiles are available for various applications such as deep snow, high performance, luxury touring, and trail riding, for example. In general, a snowmobile has a chassis on or around which the various components of the snowmobile are assembled. Typical snowmobiles include one or more skis for steering, a seat, handlebars, and an endless track for propulsion mounted to a central chassis. The engine drives a ground-engaging endless track disposed in a longitudinally extending drive tunnel. The skis serve to facilitate steering as well as to provide flotation of the front of the snowmobile over the snow in which it is operated. A handlebar assembly, positioned forward of the seat, is operatively linked to the skis for steering the snowmobile. The skis may be pivoted to steer the snowmobile, for example, by turning the handlebars.

[0003] At least some snowmobile frames include a tunnel and a front chassis portion which retains the power train, and a front suspension that mounts skis to the frame. A drive shaft is typically mounted to the front chassis portion and includes drive sprockets for powering a belt. A chain case, belt drive case, or gear box is also typically provided to transfer power from an engine or CVT (continuously variable transmission) to the drive shaft. A typical snowmobile may include a drivetrain with a drive shaft and an upper jack shaft that drives the drive sprocket(s) through the chain case, belt drive case, or gear box. CVTs are also utilized for snow bikes, motorcycles, and all-terrain vehicles (ATVs).

SUMMARY

[0004] Embodiments of the present disclosure describe a drive pulley for a continuously variable transmission including a stationary sheave with a stationary shaft, a movable sheave axially movable relative to the stationary sheave and in contact with the stationary shaft; a spider in contact with at least the moveable sheave and stationary shaft; a spring member, biasing the movable sheave axially away from the stationary sheave; at least one centrifugal actuator including an arm pivotally connected to one of the movable sheave and the spider, the arm pivoting away from the one of the movable sheave and the spider as a speed of rotation of the drive pulley increases, the arm pushing against another one of the movable sheave and the spider as the arm pivots away from the one of the movable sheave and the spider, thereby moving the movable sheave axially toward the stationary sheave, the at least one centrifugal actuator being disposed radially outward of the stationary sheave shaft; and a torque transfer assembly operatively connected to at least one of the spider and the movable sheave, the torque transfer assembly

transferring torque between the spider and the movable sheave, the torque transfer assembly including, a torque bearing assembly and at least one roller assembly, positioned on a helixed torque pin, the torque pin connected to the spider; wherein as the roller assembly wears, the at least one roller assembly tracks along a helixed path of the torque pin in a distal direction from the bearing assembly.

[0005] Embodiments also describe a drive pulley for a continuously variable transmission including a stationary sheave with a stationary shaft; a movable sheave axially movable relative to the stationary sheave and in contact with the stationary shaft; a spider in contact with at least the moveable sheave and stationary shaft; a spring member, biasing the movable sheave axially away from the stationary sheave; at least one centrifugal actuator including an arm pivotally connected to one of the movable sheave and the spider, the arm pivoting away from the one of the movable sheave and the spider as a speed of rotation of the drive pulley increases, the arm pushing against another one of the movable sheave and the spider as the arm pivots away from the one of the movable sheave and the spider, thereby moving the movable sheave axially toward the stationary sheave, the at least one centrifugal actuator being disposed radially outward of the stationary sheave shaft; and a torque transfer assembly operatively connected to at least one of the spider and the movable sheave, the torque transfer assembly transferring torque between the spider and the movable sheave, the torque transfer assembly including, a torque bearing assembly and at least one slider block assembly, positioned on a helixed torque pin, the torque pin connected to the spider; wherein as the slider block assembly wears, the at least one slider block assembly tracks along a helixed path of the torque pin in a distal direction from the bearing assembly.

[0006] Embodiments further include a drive pulley for a continuously variable transmission including a stationary sheave, with a stationary shaft; a movable sheave axially movable relative to the stationary sheave and in contact with the stationary shaft;

[0007] a spider in contact with at least the moveable sheave and stationary shaft; a spring member, biasing the movable sheave axially away from the stationary sheave; at least one centrifugal actuator including an arm pivotally connected to one of the movable sheave and the spider, the arm pivoting away from the one of the movable sheave and the spider as a speed of rotation of the drive pulley increases, the arm pushing against another one of the movable sheave and the spider as the arm pivots away from the one of the movable sheave and the spider, thereby moving the movable sheave axially toward the stationary sheave, the at least one centrifugal actuator being disposed radially outward of the stationary sheave shaft; and a torque transfer assembly operatively connected to at least one of the spider and the movable sheave, the torque transfer assembly transferring torque between the spider and the movable sheave, the torque transfer assembly including, a button slider block assembly, positioned on a torque pin, the torque pin connected to the spider; wherein the button slider block assembly is removable.

BRIEF DESCRIPTION OF DRAWINGS

[0008] This written disclosure describes illustrative embodiments that are non-limiting and non-exhaustive. Reference is made to illustrative embodiments that are depicted in the figures, in which:

[0009] FIG. 1 illustrates a perspective view 100 of a snowmobile, according to some embodiments.

[0010] FIGS. 2A-B illustrate perspective views 200 of a snowmobile without a shroud and seat, according to some embodiments.

[0011] FIGS. 3A-D illustrate perspective views 300 of snowmobile engine and drive train components, according to some embodiments.

[0012] FIGS. 4A-J illustrate perspective and cross-sectional views of CVT spider with roller-roller torque transfer assembly in a wear configuration, according to some embodiments.

[0013] FIGS. 5A-J illustrate perspective and cross-sectional views of CVT spider with roller-roller torque transfer assembly in a no wear configuration, according to some embodiments.

[0014] FIGS. 6A-H illustrate perspective and cross-sectional views of CVT drive clutch with roller-roller torque transfer assembly in a no wear and full shift configuration, according to some embodiments.

[0015] FIGS. 7A-H illustrate perspective and cross-sectional views of CVT drive clutch with roller-roller torque transfer assembly in a wear and full shift configuration, according to some embodiments.

[0016] FIGS. 8A-I illustrate exploded, perspective and cross-sectional views of CVT drive clutch with roller-roller torque transfer assembly in a wear and no shift configuration, according to some embodiments.

[0017] FIGS. 9A-I illustrate exploded, perspective and cross-sectional views of CVT electric start drive clutch with roller-roller torque transfer assembly in a wear and no shift configuration, according to some embodiments.

[0018] FIGS. 10A-J illustrate exploded, perspective and cross-sectional views of CVT drive clutch with roller-roller torque transfer assembly in a no wear and no shift configuration, according to some embodiments.

[0019] FIG. 11 illustrates an exploded view of CVT electric start drive clutch with button torque transfer assembly in a full shift configuration with shift stop, according to some embodiments.

[0020] FIGS. 12A-I illustrate perspective and cross-sectional views of a cam arm, according to some embodiments.

[0021] FIGS. 13A-K illustrate exploded, perspective and cross-sectional views of CVT drive clutch with slider-roller torque transfer assembly in a wear and full shift configuration, according to some embodiments.

[0022] FIGS. 14A-J illustrate perspective and cross-sectional views of CVT drive clutch with slider-roller torque transfer assembly in a wear and no shift configuration, according to some embodiments.

[0023] FIGS. 15A-K illustrate perspective and cross-sectional views of CVT spider with roller-slider torque transfer assembly in a wear configuration, according to some embodiments.

[0024] FIGS. 16A-I illustrate exploded, perspective and cross-sectional views of CVT drive clutch calibrated for use in a two-stroke engine, according to some embodiments.

[0025] FIGS. 17A-J illustrate perspective and cross-sectional views of CVT spider with button block torque transfer assembly for use in a two-stroke engine, according to some embodiments.

[0026] FIGS. 18A-E illustrate exploded, perspective and cross-sectional views of an uncalibrated CVT drive clutch with button block torque transfer assembly for use in a

two-stroke engine in a no shift, no shift stop configuration, according to some embodiments.

[0027] FIGS. 19A-D illustrate perspective and cross-sectional views of an uncalibrated CVT drive clutch with button block torque transfer assembly for use in a two-stroke engine in a full shift, no shift stop configuration, according to some embodiments.

[0028] FIGS. 20A-E illustrate exploded, perspective and cross-sectional views of an uncalibrated electric start CVT drive clutch with button block torque transfer assembly for use in a two-stroke engine in a no shift configuration, according to some embodiments.

[0029] FIGS. 21A-F illustrate exploded, perspective and cross-sectional views of an uncalibrated CVT drive clutch with damper ring for use in a two-stroke engine in a full shift configuration, according to some embodiments.

[0030] FIGS. 22A-E illustrate perspective and cross-sectional views of an uncalibrated CVT drive clutch with damper ring for use in a two-stroke engine in a no shift configuration, according to some embodiments.

[0031] FIGS. 23A-I illustrate exploded, perspective and cross-sectional views of an ATV, side by side (SXS), snow-bike, or motorcycle CVT drive clutch with windage plate for use in a two-stroke or four-stroke engine in a full shift, no shift stop, configuration, according to some embodiments.

[0032] FIGS. 24A-I illustrate exploded, perspective and cross-sectional views of an ATV, side by side (SXS), snow-bike, or motorcycle CVT drive clutch with windage plate for use in a two-stroke or four-stroke engine in a no shift, no shift stop configuration, according to some embodiments.

[0033] FIG. 25 illustrates a perspective view of an ATV or motorcycle CVT spider with button block assembly for use in a four-stroke engine, according to some embodiments.

[0034] FIGS. 26A-I illustrate perspective and cross-sectional views of an ATV or motorcycle CVT spider with button block assembly for use in a four-stroke engine, according to some embodiments.

[0035] FIGS. 27A-E illustrate perspective and cross-sectional views of a CVT cover assembly, according to some embodiments.

[0036] FIGS. 28A-K illustrate perspective and cross-sectional views of a CVT moveable sheave assembly, according to some embodiments.

[0037] FIGS. 29A-B illustrate perspective and cross-sectional views of a CVT stationary sheave assembly, according to some embodiments.

[0038] FIGS. 30A-E illustrate perspective and cross-sectional views of a CVT spider hub according to some embodiments.

[0039] FIGS. 31A-G illustrate perspective and cross-sectional views of a CVT eccentric cam assembly, according to some embodiments.

[0040] FIGS. 32A-E illustrate perspective and cross-sectional views of a CVT eccentric cam slider block assembly, according to some embodiments.

[0041] FIGS. 33A-H illustrate perspective and cross-sectional views of a CVT torque pin, according to some embodiments.

[0042] FIGS. 34A-J illustrate perspective and cross-sectional views of a CVT torque pin with helix, according to some embodiments.

[0043] FIGS. 35A-G illustrate perspective and cross-sectional views of a CVT wear-sleeved bearing assembly, according to some embodiments.

[0044] FIGS. 36A-E illustrate perspective and cross-sectional views of a CVT button block assembly, according to some embodiments.

[0045] FIGS. 37A-E illustrate perspective and cross-sectional views of a CVT roller assembly, according to some embodiments.

[0046] FIGS. 38A-H illustrate perspective and cross-sectional views of a CVT button block assembly with dampers, according to some embodiments.

DETAILED DESCRIPTION

[0047] Conventional snowmobile powertrains incorporate a continuously variable transmission (CVT) having a drive pulley that is operatively coupled to the engine crankshaft and a driven pulley coupled to a driven shaft. The drive pulley transfers torque to the driven pulley via a drive belt looped around both pulleys. Typically, the driven shaft is a transverse jackshaft which drives the input member of a chain and sprocket reduction drive. The output of the reduction drive is coupled to one end of an axle on which are located one or more drive track drive sprockets.

[0048] The drive pulley includes centrifugal actuators through which the drive ratio of the drive pulley is varied progressively as a function of the engine speed and load. The centrifugal actuators are connected to a movable sheave of the drive pulley. The drive pulley also includes a fixed sheave which is axially fixed. The fixed sheave and the movable sheave are rotatable together. The movable sheave is movable axially toward the fixed sheave by the action of the centrifugal actuators and away from the fixed sheave by a biasing spring. The centrifugal actuators generally include centrifugal weights in the form of adjusting arms. Each of the arms is connected to the movable sheave of the drive pulley by a pin, and pivots outwards about its corresponding pin. As they pivot, the arms are in contact with corresponding rollers disposed on a spider fixed relative to the fixed sheave. When the adjusting arms pivot outwards as a result of centrifugal force, they slide against their corresponding roller and the axially movable sheave is pushed towards the fixed sheave.

[0049] Due to manufacturing tolerances and the type of connection used, it is possible that the spider and movable sheave can rotate slightly relative to one another during acceleration and deceleration of the drive pulley. As a result, the adjusting arms move slightly in a direction generally parallel to an axis of rotation or their corresponding rollers. This is sometimes referred to as backlash. This slight movement causes rubbing of the adjustable arms against their respective rollers and can result in portions of the arms, the rollers or both to wear.

[0050] Embodiments of the present disclosure provide wear adjusting torque transfer devices, such as roller, slider, and button (solid or damped) block assemblies. In some embodiments, the wear adjusting feature is optional or removable. In one embodiment, a spider in a primary drive clutch of a CVT system uses rollers to transfer torque. Two rollers can be utilized, one for primary forward torque and one for reverse and engine braking torque. In addition to reverse engine braking, the secondary roller (or button or slider, in other embodiments) can be engaged when slowing down. The secondary roller can become the primary forward torque roller during engine reverse operation. The primary torque roller can be on the centerline axis of its locating pin. The secondary torque roller can be located on an eccentric

cam on the centerline axis of the locating pin. The eccentric cam has a one-way clutch to allow adjustment of slack from component wear, but not the return to a slack condition. To aide the wear adjustment, a method of providing rotatory force to the cam, such as with a torsional spring, can be utilized.

[0051] In another embodiment, a method for adjustment relies on a mass for the reverse torque roller. This mass would be a part of the eccentric cam feature. The centrifugal force acting on the mass would move the cam mass outward, and by having this cam in contact and guided by a helixed spline or helixed track, causes the cam to rotate as the mass moves outward radially to adjust for wear in the primary and secondary rollers.

[0052] By separating the torque transfer device and the cam actuation portion of the drive clutch to different locations (such as a 60 degree offset), a roller to transfer torque can be utilized, as compared to a sliding button, in one embodiment. The torque transfer system can be utilized in a forward and reverse torque transfer roller system. The forward or primary torque transfer roller can be on the axial centerline of the locating/torque transfer pin. The reverse or secondary torque transfer roller can be located on an eccentric cam. This eccentric cam is free to rotate about the axial centerline of the torque transfer pin, but with the addition of a one-way bearing/clutch it can only rotate in one direction to take up the slack/wear of the rollers. The eccentric cam can be coaxially located on the torque transfer pin with a bushing. The eccentric cam can be aided in wear slack take-up by a member that provides torque to the cam, such as a torsion spring. The rollers can transfer torque between the spider (fixed to the post or stationary shaft of the drive clutch) and the moveable sheave. The moveable sheave travels axially up and down the stationary shaft post to change the ratio of the CVT system. The rollers can be cylindrical in the radial direction to the centerline of the clutch along the axis of the torque transfer pin. The spider design can allow for slight movement radially from the centerline of the drive clutch to ease in assembly, but not in a manner to take up the slack in the fit of the spider to moveable sheave.

[0053] Such example embodiments provide a quieter, narrower drive clutch, with fewer parts, allowing for narrower body shrouding on the vehicle. The CVT drive clutch can be reduced in width or thickness by 25-30 mm for example. The embodiments described herein also provide for easier servicing or replacement of worn parts, while maintaining performance and durability of the CVT system.

[0054] Referring to FIG. 1, a perspective view **100** of a snowmobile is shown, according to some embodiments. A chassis **104** or frame supports an engine (see FIG. 2A), drive or power train (see FIG. 2A), a drive track **106**, handlebars **102** and skis **112**. A shroud **110** or fairing in contact with the chassis covers and protects various components of the vehicle. A seat **108** is positioned rearward of the handlebars **102**. With the shroud **110** and seat **108** removed (see FIGS. 2A-B), the engine **202** is shown in contact with a drive train **204**. The drive train **204** includes a continuously variable transmission (CVT), for transferring power from the engine **202** to the drive track **106**.

[0055] Referring to FIGS. 3A-D, perspective views **300** of snowmobile engine and drive train **204** components are shown, according to some embodiments. An engine **202** converts chemical energy to mechanical energy via a rotat-

ing input shaft in contact with a transmission or drive train **204**, such as a CVT. The CVT includes a rotatable drive (or primary) clutch **302** connected to the input shaft. The CVT also includes a rotatable driven (or secondary) clutch **304** connected to an output shaft or jack shaft **314**, the driven clutch **302** having a laterally stationary sheave and a laterally movable sheave that is normally biased toward the stationary sheave. An endless flexible drive belt **306** is disposed about the drive **302** and driven clutches **304**. Typically, the CVT transmission is connected to the output shaft of the vehicle's engine, the transmission providing continuously variable gear reduction from the relatively higher rotation speed of the engine to the relatively lower rotation speed of the vehicle drive axle. A CVT may be used in conjunction with an additional gear box/transmission **312**, if desired. For example, it may be desirable to provide a gear box **312** to permit the driver to shift between forward and reverse gears. In such cases, a neutral position may also be provided, along with, e.g., an optional low gear for extra power at low speeds. Typically, such a gear box **312** is connected to the jack shaft **314** of the CVT, the gear box **312** in turn having a drive shaft **308** connected by suitable linkages (sprockets **310**, for example) to the drive track **106**.

[0056] The endless, flexible, generally V-shaped drive belt **306** is disposed about the clutches **302**, **304**. Each of the clutches has a pair of complementary sheaves, one of the sheaves being laterally movable with respect to the other. The effective gear ratio of the transmission is determined by the positions of the movable sheaves in each of the clutches. The secondary driven clutch **304** has its sheaves normally biased together (e.g., by a compression spring working in combination with a helix-type cam, as described below), so that when the engine is at idle speeds the drive belt rides near the outer perimeter of the driven clutch sheaves.

[0057] The spacing of the sheaves in the primary drive clutch **302** usually is controlled by centrifugal flyweights (such as a cam arm). As the drive clutch **302** rotates faster (in response to increased engine rpm) the flyweights urge the movable sheave toward the stationary sheave. This pinches the drive belt **306**, causing the belt **306** to begin rotating with the drive clutch **302**, the belt in turn causing the driven clutch **304** to begin to rotate. Further movement of the drive clutch's **302** movable sheave toward the stationary sheave forces the belt **306** to climb outwardly on the drive clutch sheaves, increasing the effective diameter of the drive belt path around the drive clutch **302**. Thus, the spacing of the sheaves in the drive clutch **302** changes based on engine rpm. The clutch therefore can be said to be speed sensitive.

[0058] As the sheaves of the drive clutch **302** pinch the drive belt **306** and force the belt **306** to climb outwardly on the drive clutch sheaves, the belt **306** (not being stretchable) is pulled inwardly between the sheaves of the driven clutch **304**, decreasing the effective diameter of the drive belt path around the driven clutch **304**. This movement of the belt **306** inwardly and outwardly on the drive **302** and driven clutches **304** smoothly changes the effective gear ratio of the transmission in infinitely variable increments.

[0059] FIGS. 4A-J illustrate perspective and cross-sectional views of CVT snow spider with roller-roller torque transfer assembly in a wear configuration, according to some embodiments. Spider body **402** includes torque transfer device assemblies **412** and actuator assemblies **410**. Each torque transfer device assembly **412** and actuator assembly **410** are offset about 60 degrees from the adjacent assembly

or about 120 degrees from an adjacent similar assembly. Actuator rollers **404** can be secured to the spider body **402** by a cam roller pin **406** and cam roller cap or fastener **408**. In this embodiment, the torque transfer device assembly **412** includes a torque bearing assembly **416**, an eccentric roller assembly **418** and torque pin **420**. The torque pin **420** fastens to the spider body **402** and can be further secured by securing pin **422** through securing pin aperture **426**. The torque pin **420** can be positioned in torque pin aperture **424**. A hub **427** can be secured to the spider body **402** with fasteners **428**, and an interference fit. The hub **427** includes a shaft aperture **431**, in line with aperture **430** for integration with a stationary sheave post or shaft (such as by threading). The optional interference fit can be facilitated by conical shaped points (i.e., the taper of the parts fit together like two cones stacking) of contact at the hub **427** and spider body **402**. Load can then be further transferred through the hub **427** and less through the fasteners **428**. The walls surrounding hub aperture **431**, walls surrounding spider aperture **430**, or both can be tapered. The walls of apertures, **431**, **430** can be tapered about 0.5% to 2%, or about 1% to about 1.5%, for example. A wear configuration describes a CVT configuration after substantial wear of the indicated parts. A no wear configuration describes new or nearly new parts before any substantial wear has occurred. Wear can include about a 0.1% to about a 10% reduction by mass or surface area of a part. Wear can include 0.5% to about 5%, about 1% to about 7%, or about 2% to about 8% reduction in mass or surface area.

[0060] The spider body **402** can be manufactured of aluminum or be substantially manufactured of aluminum, for example. The hub **427** may be manufactured of steel to provide additional strength to the spider body **402** and reduce the overall width or thickness of the assembly. Optionally, the hub **427** can be integrated as part of the spider body **402**, if made of the same material. The aluminum spider body **402** and steel hub **427** can be secured together with fasteners **428**, but torque is transmitted through a combination of the fastener bolted joint, as well as the interference fit between the aluminum and steel components, such as with a press fit. The interference fit and bolt clamp load help transfer torque.

[0061] The unique shape of having the actuator assembly **410** 60 degrees offset to the torque transfer device **412** (slider or roller) allows for a more compact design and width of the drive clutch by tucking the torque transfer mechanism into the casting profile, and profiling the cam arm roller support structure of the actuator assembly **410** to the movable sheave casting profile. Torque transfer device **412** is positioned further centrally than on traditional spiders and provides additional reduction in diameter and overall weight.

[0062] The eccentric roller assembly **418** separates from the torque bearing assembly **416** as the roller follows the helixed path of the torque pin **420** as wear occurs. The eccentric path provides alternating contact between the torque bearing assembly **416** and eccentric roller assembly **418**, extending the life of the system while allowing easier access for service and replacement. As the primary assembly **418** wears from travel up and down the tower or post, the secondary assembly **416** moves up the one-way helixed path, forcing a closer fit against a tower face in a forward moving configuration or against an opposite tower face in a reverse (or slowing down) configuration, or both. Line **432**

of FIG. 4I shows the offset contact of the rollers with a tower or post. Rollers 404 can be easily removed and replaced as wear occurs by contact with a cam arm.

[0063] FIGS. 5A-J illustrate perspective and cross-sectional views of CVT snow spider with roller-roller torque transfer assembly in a no wear configuration, according to some embodiments. In the no wear configuration, the positioning of the torque bearing assembly 416 and eccentric roller assembly 418 are immediately adjacent, as the eccentric roller assembly 418 has not started climbing the helixed path of the torque pin 420. Line 432 of FIG. 5I shows the offset, but with new or nearly new parts showing no substantial wear.

[0064] FIGS. 6A-H illustrate perspective and cross-sectional views of CVT drive clutch with roller-roller torque transfer assembly in a no wear and full shift configuration, according to some embodiments. In all fully shifted configurations, stationary sheave 600 and moveable sheave 602 are in close proximity or in contact near an axial line. As the drive clutch 302 shifts, the cam arms 608 push away from and on rollers 404, moving the sheaves 600, 602 together. The moveable sheave 602 rides along stationary post or shaft 604. The spider 402 is in contact with a plurality of towers 610 of the moveable sheave 602. The towers 610 are shorter and positioned further inward than traditional moveable sheaves 602. The torque transfer device assembly 412 is in contact with the towers 610, which can incur wear as the CVT is engaged. The enhanced cross-sectional view in FIG. 6H shows the offset gap 614 between eccentric roller assembly 418 and tower 610. FIGS. 7A-H illustrate perspective and cross-sectional views of CVT drive clutch with roller-roller torque transfer assembly in a wear and full shift configuration, according to some embodiments.

[0065] FIGS. 8A-I illustrate exploded, perspective and cross-sectional views of CVT drive clutch with roller-roller torque transfer assembly in a wear and no shift configuration, according to some embodiments. A stationary post or shaft 604 of a stationary sheave 600 can be in contact with one or more thrust washers 800, idler bearing 802, and collar 804 before assembly with moveable sheave 602. The collar 804 can act as an extension of the stationary shaft, concentric to the idler bearing allowing the moveable sheave to transition from collar to idler bearing 802 as the sheave travels axially. The collar 804 can be optionally integrated into the shaft 604. One of more of thrust washers 800 can be integrated with collar 804 or idler bearing 802. Alternatively, spider body 402 or hub 427 can integrate collar 804 and one or more thrust washers 800 or spacers/washers 816, 818. In one embodiment, the hub can be machined to include spacers/washers 816, 818. An inner belt rides on the bearing 802 prior to clutch engagement. This configuration also allows for more consistent belt tensions and lessens or eliminates the need for a user to manually adjust driven clutch sheave spacing, affecting belt deflection and drive ratio. The idler bearing 802 can be a two-way or multi-directional roller bearing positioned on an input shaft (either directly or indirectly) and in contact with an interior surface of the belt. The positioning of bearing 802 allows for the input shaft to rotate while in idle without engaging the belt. The belt can maintain tension, even in idle, and a user does not have to periodically monitor and manually adjust belt tension. Further, the belt can now engage the sheaves at a

lower position (closer to the input shaft) and in a lower powerband, accessing higher torque, lower speed applications.

[0066] Because the belt 306 is maintained at a higher tension (i.e., tighter) in idle, the neutral gap (gap between two sheaves when at idle state without belt) is larger and the sheaves move less to engage the belt 306. The belt gap (distance between the belt and each sheave) is also tighter, which contributes to more consistent belt 306 tension, better engagement out of idle and less movement needed by the sheaves to engage.

[0067] One or more cam arms 608 can be fastened to the moveable sheave with a cam arm pin 806 and cam arm pin fastener 808. Further, a spider body 402 engages the post 604 and sheave 602 at towers 610 and with calibration shim 816 and neutral gap washer 818. The calibration shim 816 affects the angle and range of cam arm 608 movement and pathing.

[0068] A cover 606 secures spring 612 (or other biasing member) while retaining ring 812 and optional shift stop 810 are installed onto the stationary shaft 604 prior to cover 606 and spring 612 installation. The spider 402 design allows for a greater recess to position spring 612. The retaining ring 812 provides an additional safety measure of securing the spider 402 in case of it loosening over time. The retaining ring 812 can be a snap ring for example. The ring 812 fits inside the diameter of the spring 612 and replaces the use of a traditional jam nut. In one embodiment, the retaining ring 812 can be positioned within a groove or recess (not shown) of the spider body 402 or shaft 604. Additionally, collar 804 can be positioned over the ring 812. The ring 812 can prevent full separation from stationary shaft 604. The shift stop 810 limits travel and prevents the sheaves 600, 602 from touching, preventing wear. The shift stop 810 can create a gap between sheaves 600, 602 of 0.1 mm to about 3.5 mm, about 0.5 mm to about 2.5 mm, or about 1 mm to about 2 mm, for example. The shift stop 810 can be in contact with a sheave shoulder 605, the shoulder configured in various thickness to speed or ratio requirements across different vehicle designs. Fasteners 814 secure the cover 606 to the spider body 402. A no shift configuration, the spring 612 provides tension to keep sheaves 600 and 602 apart until shifting is engaged. In a wear configuration, gap 614 shows the space between eccentric roller 418 and tower 610 and gap 616 shows the distance traveled up the helix of the torque pin 420.

[0069] FIGS. 9A-I illustrate exploded, perspective and cross-sectional views of CVT electric start drive clutch with roller-roller torque transfer assembly in a wear and no shift configuration, according to some embodiments. An electric start ring 900, secured to the stationary sheave 600 by fasteners 902 is shown. FIGS. 10A-J illustrate exploded, perspective and cross-sectional views of CVT drive clutch with roller-roller torque transfer assembly in a no wear and no shift configuration, according to some embodiments. FIG. 11A illustrates an exploded view of CVT electric start drive clutch with button torque transfer assembly in a full shift configuration with shift stop, according to some embodiments. The torque transfer device assembly 412 includes a button block assembly 1102.

[0070] Referring to FIGS. 12A-I, perspective and cross-sectional views of a cam arm 608 is shown, according to some embodiments. Cam arm 608 includes upper contact area 1202, cam arm pin sleeve 1204, and upper contact area

lip **1206**. A traditional cam arm or flyweight **608** has a rectangular profile in a front view, such as in FIG. **12E**. In this embodiment, the upper contact area **1202** that engages the spider body **402** to move the moveable sheave **602** has a T-shape, increasing surface area contacted. The lip **1206** can be symmetric to form a T-shape, or in one embodiment can be asymmetric or only present on one side to form an L-shape. The surface area of the upper contact area **1202** can be increased about 5%, about 10%, about 15%, about 20%, about 30%, or about 35% more over a rectangular (non-T shaped) profiled cam arm **608**. By increasing the surface area of the upper contact area **1202**, less stress is placed on the cam arm **608** over time and the overall weight of the cam arm **608** can be reduced.

[0071] By changing the shape and profile of the upper contact area **1202**, the center of mass of cam arm **608** can be changed. Cam arm **608** mass varies based on uncalibrated clutch positioning of the roller on the spider and the cam arm pin **806**. The mass also varies based on the shape of the upper contact area **1202**. The cam arm pin sleeve **1204** (e.g., bushing) receives cam arm pin **806** for securing to the moveable sheave **602**. Cam arm **608** can be manufactured of powdered metal (e.g., iron with binder), steel, composite materials, etc. The cam arm **608** material can be chosen based on cost, density, and durability.

[0072] In a T-shaped configuration, each lip **1206** can be about 5% of the total width of the upper contact area. The width of each lip can be about 10%, about 15%, or about 20% of the total width of the upper contact area **12002** width, for example.

[0073] FIGS. **13A-K** illustrate exploded, perspective and cross-sectional views of CVT drive clutch with slider-roller torque transfer assembly in a wear and full shift configuration with shift stop, according to some embodiments. In this embodiment, the torque transfer device assembly **412** includes a slider block assembly **1300**. FIGS. **14A-J** illustrate perspective and cross-sectional views of CVT drive clutch with slider-roller torque transfer assembly in a wear and no shift configuration with shift stop, according to some embodiments. FIGS. **15A-J** illustrate perspective and cross-sectional views of CVT spider with roller-slider torque transfer assembly in a wear configuration, according to some embodiments. The slider block assembly **1300** includes eccentric slider block **1302** and eccentric slider cam **1304**. Unlike a roller, the slider block assembly **1300** slides up and down the tower **610** as opposed to rolling. Using the helixed path of torque pin **420**, the torque transfer device **412** can reduce wear and extend the life of the assembly. FIGS. **16A-I** illustrate exploded, perspective and cross-sectional views of CVT drive clutch calibrated with button block assembly for use in a two-stroke engine, according to some embodiments. A calibrated system fully includes cam arms **608** and spring **612**. Calibration can also refer to the position of the spider body **402** in relation to the moveable sheave **602**.

[0074] FIGS. **17A-J** illustrate perspective and cross-sectional views of CVT spider with button block assembly for use in a two-stroke engine, according to some embodiments. The torque transfer device assembly **412** includes button block assembly **1102**. The assembly **1102** includes button block body **1702** and securing pin **1704** through securing pin apertures **1706**. Securing pin **1704** can provide orientation of the button block body **1702** by securing pin apertures **1706**

relative to the spider **412**. The spider **412** can be equipped with or without securing pin **1704** depending on the application.

[0075] FIGS. **18A-E** illustrate exploded, perspective and cross-sectional views of an uncalibrated CVT drive clutch with button block torque transfer assembly for use in a two-stroke engine in a no shift, no shift stop configuration, according to some embodiments. FIGS. **19A-D** illustrate perspective and cross-sectional views of an uncalibrated CVT drive clutch with button block torque transfer assembly for use in a two-stroke engine in a full shift, no shift stop configuration, according to some embodiments. FIGS. **20A-E** illustrate exploded, perspective and cross-sectional views of an uncalibrated electric start CVT drive clutch with button block torque transfer assembly for use in a two-stroke engine in a no shift configuration, according to some embodiments.

[0076] FIGS. **21A-F** illustrate exploded, perspective and cross-sectional views of an uncalibrated CVT drive clutch with damper ring for use in a two-stroke engine in a full shift configuration with shift stop, according to some embodiments. A damper ring **2100** can be secured to sheave **602** with fasteners **2102**. The damper ring **2100** can provide additional inertia to the engine, especially in cases where an electric start is absent. FIGS. **22A-E** illustrate perspective and cross-sectional views of an uncalibrated CVT drive clutch with damper ring for use in a two-stroke engine in a no shift configuration with shift stop, according to some embodiments. FIGS. **23A-I** illustrate exploded, perspective and cross-sectional views of an ATV, side by side (SXS), snowbike, or motorcycle CVT drive clutch with damped button block torque transfer assembly and windage plate for use in a two-stroke or four-stroke engine in a full shift configuration, according to some embodiments. Additionally, a fan **2300** can be integrated with stationary sheave **600** for dirt applications. Dirt, or non-snow, applications tend to operate in higher ambient temperature environments and the CVT is often encased in an enclosed shroud (i.e., box) to protect from debris. These factors lead increased air flow considerations. FIGS. **24A-I** illustrate exploded, perspective and cross-sectional views of an ATV, side by side (SXS), snowbike, or motorcycle CVT drive clutch with damped button block torque transfer assembly and windage plate for use in a two-stroke or four-stroke engine in a no shift, no shift stop configuration, according to some embodiments.

[0077] FIGS. **25** and **26A-I** illustrate perspective and cross-sectional views of an ATV or motorcycle CVT spider with button block assembly for use in a two- or four-stroke engine, according to some embodiments. Hub **2500** includes additional thickness and structural features as an option for a four-stroke engine application that can function as neutral gap and calibration shims as previously seen.

[0078] FIGS. **27A-E** illustrate perspective and cross-sectional views of a CVT cover assembly, according to some embodiments. Cover **606** can be secured to moveable sheave **602** with fasteners and stationary post **604** with bearing **2700**, for example. Cover **606** supports towers **610** and further secures the towers **610** from moving or flexing outward. FIGS. **28A-K** illustrate perspective and cross-sectional views of a CVT moveable sheave assembly, according to some embodiments. Moveable sheave **602** can be secured using bearing **2802** and retaining ring **2804**, for example. Structural ribbing **2800** or features can be included to provide additional strength to the moveable sheave **602**

and drive clutch 302 assembly. The ribbing 2800 can reduce movement or stress on the towers and allows for placement of towers 610 on the moveable sheave 602, as opposed to positioning on the spider body 402. The structural ribbing 2800 can be fabricated or attached between towers 610 and an inner surface of the sheave or between features in contact with the inner surface of the sheaves. The ribbing 2800 can include 2 or more, 5 or more, 20 or more, or 30 or more features. The surface area covered by the ribbing 2800 on an inner surface of the sheave 602 can include 3% or more, 10% or more, 40% or more or 70% or more of the total surface area. The ribbing 2800 further secures the towers 610 from deflection and wear. The ribbing 2800 can include major and minor ribbing features.

[0079] FIGS. 29A-B illustrate perspective and cross-sectional views of a CVT stationary sheave assembly, according to some embodiments. The sheave 600 can be in contact with a crankshaft from an engine. Four-stroke engines in recreational vehicles often utilize 30 mm taper. In a two-stroke application and four-stroke dirt bike/ATV application, the crankshaft taper is often 33 mm. FIGS. 30A-E illustrate perspective and cross-sectional views of a CVT hub, according to some embodiments. As discussed above, the hub 427 can include a taper or conical shape to interface with corresponding spider body 402.

[0080] FIGS. 31A-G illustrate perspective and cross-sectional views of a CVT eccentric cam assembly, according to some embodiments. An eccentric roller assembly 418 can include roller insert or bearing 3100, pathing features 3104 or one-way clutch, and eccentric roller 3102. The insert 3100 can be optionally integrated into the roller 3102. The pathing 3104 mates or contacts with helix on torque pin 420 to create an eccentric path up the pin 420 as wear occurs.

[0081] FIGS. 32A-E illustrate perspective and cross-sectional views of a CVT eccentric cam slider block assembly, according to some embodiments. An eccentric slider block assembly 1300 can include bearing 3200, eccentric slider cam 1304, retaining ring (or thrust washer) 3202, and slider block 1302.

[0082] FIGS. 33A-H illustrate perspective and cross-sectional views of a CVT torque pin, according to some embodiments. In some embodiments, a torque pin 420 can include aperture 1706 for receiving a first securing pin and U-channel 3300 for receiving a second securing pin. The U-channel securing mechanism provides additional safety by preventing the torque pin 420 from dislodging during use, in addition to providing additional alignment. FIGS. 34A-J illustrate perspective and cross-sectional views of a CVT torque pin with helix, according to some embodiments. A helix or helixed section 3400 can be utilized to guide an eccentric cam roller or slider, for example.

[0083] FIGS. 35A-G illustrate perspective and cross-sectional views of a CVT wear-sleeved bearing assembly, according to some embodiments. A wear-sleeved bearing assembly 416 can include bearing outer shell 3500 and bearing 3502. In addition to a roller bearing, the bearing 3502 can include needle bearing, plastic or metallic bushing, for example.

[0084] FIGS. 36A-E illustrate perspective and cross-sectional views of a CVT button block assembly, according to some embodiments. A button block assembly 1102 can include body 1702, securing pin aperture 1706 and buttons 3604. The body 1702 can be manufactured of aluminum, for example. The buttons 3604 can be made of engineered

plastic, such as VESPEL that provides durability and low friction. A torque pin aperture 3608 runs transversely to aperture 1706 for securing the torque pin 420.

[0085] FIGS. 37A-E illustrate perspective and cross-sectional views of a CVT roller assembly, according to some embodiments. The roller assembly 404 can include flanged or cylindrical bearing caps 3704.

[0086] FIGS. 38A-H illustrate perspective and cross-sectional views of a CVT button block assembly with dampers, according to some embodiments. In some embodiments, the button block assembly 1102 further includes dampers 3800. In some applications the dampers 3800 can be utilized to reduce vibrational noise from an output shaft. The dampers 3800 can be positioned within caps 3604, such as by pressing. The dampers 3800 can be replaced and can be manufactured of an engineered plastic. The material can also include a controlled dampening coefficient.

[0087] Other embodiments of the present disclosure are possible. Although the description above contains much specificity, these should not be construed as limiting the scope of the disclosure, but as merely providing illustrations of some of the presently preferred embodiments of this disclosure. It is also contemplated that various combinations or sub-combinations of the specific features and aspects of the embodiments may be made and still fall within the scope of this disclosure. It should be understood that various features and aspects of the disclosed embodiments can be combined with or substituted for one another in order to form various embodiments. Thus, it is intended that the scope of at least some of the present disclosure should not be limited by the particular disclosed embodiments described above.

[0088] Thus the scope of this disclosure should be determined by the appended claims and their legal equivalents. Therefore, it will be appreciated that the scope of the present disclosure fully encompasses other embodiments which may become obvious to those skilled in the art, and that the scope of the present disclosure is accordingly to be limited by nothing other than the appended claims, in which reference to an element in the singular is not intended to mean "one and only one" unless explicitly so stated, but rather "one or more." All structural, chemical, and functional equivalents to the elements of the above-described preferred embodiment that are known to those of ordinary skill in the art are expressly incorporated herein by reference and are intended to be encompassed by the present claims. Moreover, it is not necessary for a device or method to address each and every problem sought to be solved by the present disclosure, for it to be encompassed by the present claims. Furthermore, no element, component, or method step in the present disclosure is intended to be dedicated to the public regardless of whether the element, component, or method step is explicitly recited in the claims.

[0089] The foregoing description of various preferred embodiments of the disclosure have been presented for purposes of illustration and description. It is not intended to be exhaustive or to limit the disclosure to the precise embodiments, and obviously many modifications and variations are possible in light of the above teaching. The example embodiments, as described above, were chosen and described in order to best explain the principles of the disclosure and its practical application to thereby enable others skilled in the art to best utilize the disclosure in various embodiments and with various modifications as are

suited to the particular use contemplated. It is intended that the scope of the disclosure be defined by the claims appended hereto

[0090] Various examples have been described. These and other examples are within the scope of the following claims.

What is claimed is:

1. A drive pulley for a continuously variable transmission, comprising:

- a stationary sheave, including a stationary shaft;
- a movable sheave axially movable relative to the stationary sheave and in contact with the stationary shaft;
- a spider in contact with at least the movable sheave and the stationary shaft;
- a spring member, biasing the movable sheave axially away from the stationary sheave;
- at least one centrifugal actuator including an arm pivotally connected to one of the movable sheave and the spider; and
- a torque transfer assembly disposed on the spider, the torque transfer assembly including:
 - a torque pin having a helixed path, and a torque bearing assembly receiving the torque pin therethrough.

2. The drive pulley of claim 1, wherein the torque transfer assembly includes a slider block assembly including a slider block having a torque pin aperture extending through the slider block.

3. The drive pulley of claim 2, wherein the torque transfer assembly includes a slider cam received within the torque pin aperture of the slider block.

4. The drive pulley of claim 3, wherein the slider cam is configured to travel along the helixed path of the torque pin, wherein the slider cam is rotatably coupled with the slider block to urge movement of the slider block relative to the torque pin.

5. The drive pulley of claim 2, wherein the slider block assembly is configured to travel along the helixed path of the torque pin.

6. The drive pulley of claim 1, wherein the at least one centrifugal actuator is positioned approximately 60 degrees offset from at least one torque transfer assembly.

7. The drive pulley of claim 1, wherein the torque transfer assembly includes an eccentric roller receiving the helixed path of the torque pin therethrough.

8. The drive pulley of claim 7, wherein the eccentric roller is configured to travel along the helixed path of the torque pin.

9. The drive pulley of claim 1, wherein the torque pin defines a longitudinal axis pointing at the stationary shaft.

10. The drive pulley of claim 9, wherein the torque pin is secured to the spider via a securing pin, wherein the securing pin is oriented approximately orthogonal to the longitudinal axis of the torque pin.

11. The drive pulley of claim 10, wherein the torque transfer assembly is removable from the spider via disengagement of the securing pin.

12. A drive pulley for a continuously variable transmission comprising:

- a stationary sheave, including a stationary shaft;
- a movable sheave axially movable relative to the stationary sheave and in contact with the stationary shaft;
- a spider in contact with the moveable sheave;
- a spring member, biasing the movable sheave axially away from the stationary sheave;
- at least one centrifugal actuator including an arm pivotally connected to one of the movable sheave and the spider; and
- a torque transfer assembly operatively connected to at least one of the spider and the movable sheave, the torque transfer assembly transferring torque between the spider and the movable sheave, the torque transfer assembly including, a torque bearing assembly positioned on a helixed torque pin, the helixed torque pin connected to the spider.

13. The drive pulley of claim 12, wherein the torque transfer assembly includes at least one slider block assembly.

14. The drive pulley of claim 13, wherein as the at least one slider block assembly wears, the at least one slider block assembly tracks along a helixed path of the helixed torque pin in a distal direction from the torque bearing assembly.

15. The drive pulley of claim 12, wherein the arm of at least one centrifugal actuator pivots away from the one of the movable sheave and the spider as a speed of rotation of the drive pulley increases, the arm pushing against another one of the movable sheave and the spider as the arm pivots away from the one of the movable sheave and the spider, thereby moving the movable sheave axially toward the stationary sheave, the at least one centrifugal actuator being disposed radially outward of the stationary shaft.

16. The drive pulley of claim 12, wherein a helixed path of the helixed torque pin is eccentric.

17. The drive pulley of claim 12, wherein the at least one centrifugal actuator is positioned about 60 degrees offset from at least one torque transfer assembly.

18. The drive pulley of claim 13, wherein the helixed torque pin is removably secured to the spider via a securing pin.

19. The drive pulley of claim 18, wherein, upon removal of the helixed torque pin, the button slider block assembly is repositionable to remove a worn side from contact and position a different side in contact with a tower of the moveable sheave.

20. The drive pulley of claim 13, wherein the torque transfer assembly includes an eccentric roller receiving a helixed path of the helixed torque pin therethrough, wherein the eccentric roller is configured to travel along the helixed path of the helixed torque pin.

* * * * *