



US008240417B2

(12) **United States Patent**  
**Takata**

(10) **Patent No.:** **US 8,240,417 B2**

(45) **Date of Patent:** **Aug. 14, 2012**

(54) **SNOWMOBILE INCLUDING SKIS WITH KEEL AND RUNNER**

(75) Inventor: **Kazunari Takata**, Shizuoka (JP)

(73) Assignee: **Yamaha Hatsudoki Kabushiki Kaisha**, Shizuoka (JP)

(\*) Notice: Subject to any disclaimer, the term of this patent is extended or adjusted under 35 U.S.C. 154(b) by 127 days.

(21) Appl. No.: **12/697,494**

(22) Filed: **Feb. 1, 2010**

(65) **Prior Publication Data**

US 2011/0186375 A1 Aug. 4, 2011

(51) **Int. Cl.**  
**B62D 3/00** (2006.01)

(52) **U.S. Cl.** ..... **180/190**; 280/28

(58) **Field of Classification Search** ..... 180/190;  
280/28

See application file for complete search history.

(56) **References Cited**

U.S. PATENT DOCUMENTS

- 4,077,639 A 3/1978 Reedy
- 4,433,856 A \* 2/1984 Yoshida ..... 180/190
- 4,489,954 A \* 12/1984 Yasui et al. .... 280/21.1
- 5,599,030 A 2/1997 Campbell et al.

- 5,700,020 A 12/1997 Noble
- 6,626,444 B2 9/2003 Noble
- 7,096,988 B2 8/2006 Moriyama
- 7,389,995 B2 6/2008 Lemieux et al.
- 7,413,046 B2 8/2008 Okada et al.
- 2003/0151216 A1 8/2003 Takahiko
- 2004/0061296 A1\* 4/2004 Metheny ..... 280/28
- 2005/0039961 A1\* 2/2005 Moriyama ..... 180/190
- 2007/0284171 A1 12/2007 Okada et al.
- 2009/0014969 A1\* 1/2009 Musselman ..... 280/28
- 2009/0152036 A1 6/2009 Okada et al.

FOREIGN PATENT DOCUMENTS

- JP 2003-237681 A 8/2003
- JP 2005-59608 A 3/2005

\* cited by examiner

Primary Examiner — Tony Winner

(74) Attorney, Agent, or Firm — Keating & Bennett, LLP

(57) **ABSTRACT**

A snowmobile includes a body, a steering mechanism provided in the body, a steering shaft connected with the steering mechanism for associated operation with the steering mechanism, a power steering device provided in the steering shaft, a pair of skis, and a connecting section arranged to connect the skis with the body. Each of the skis includes, in its lower surface, a straight portion extending straightly; an approach portion ahead of the straight portion and curving upward; and a keel portion protruding downward to a lower position than the straight portion and the approach portion.

**4 Claims, 15 Drawing Sheets**

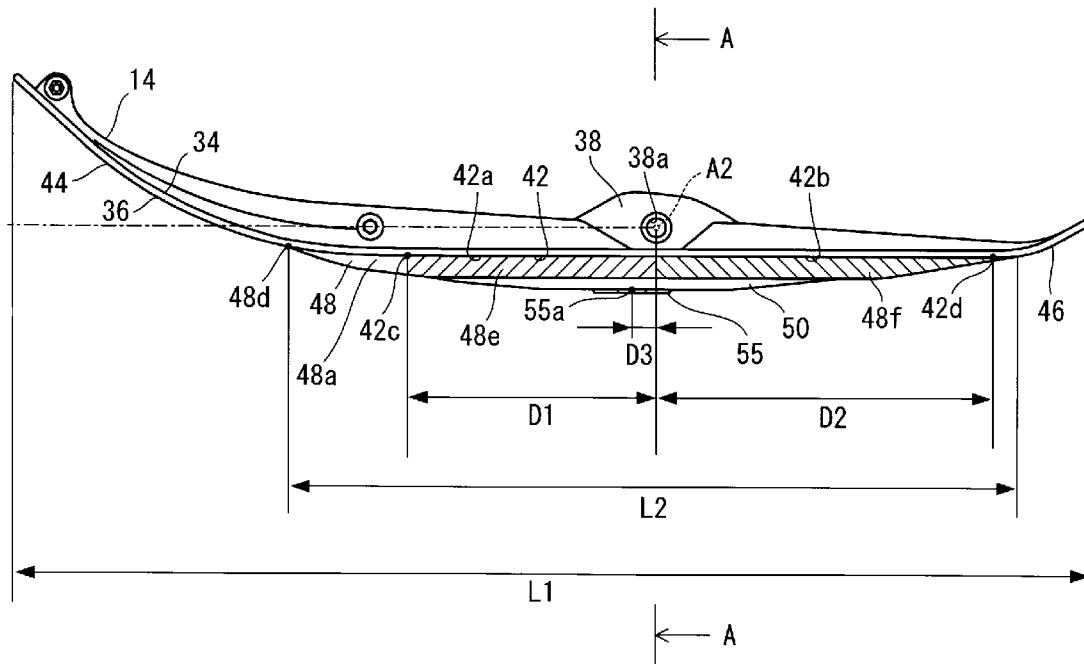



FIG. 2

10

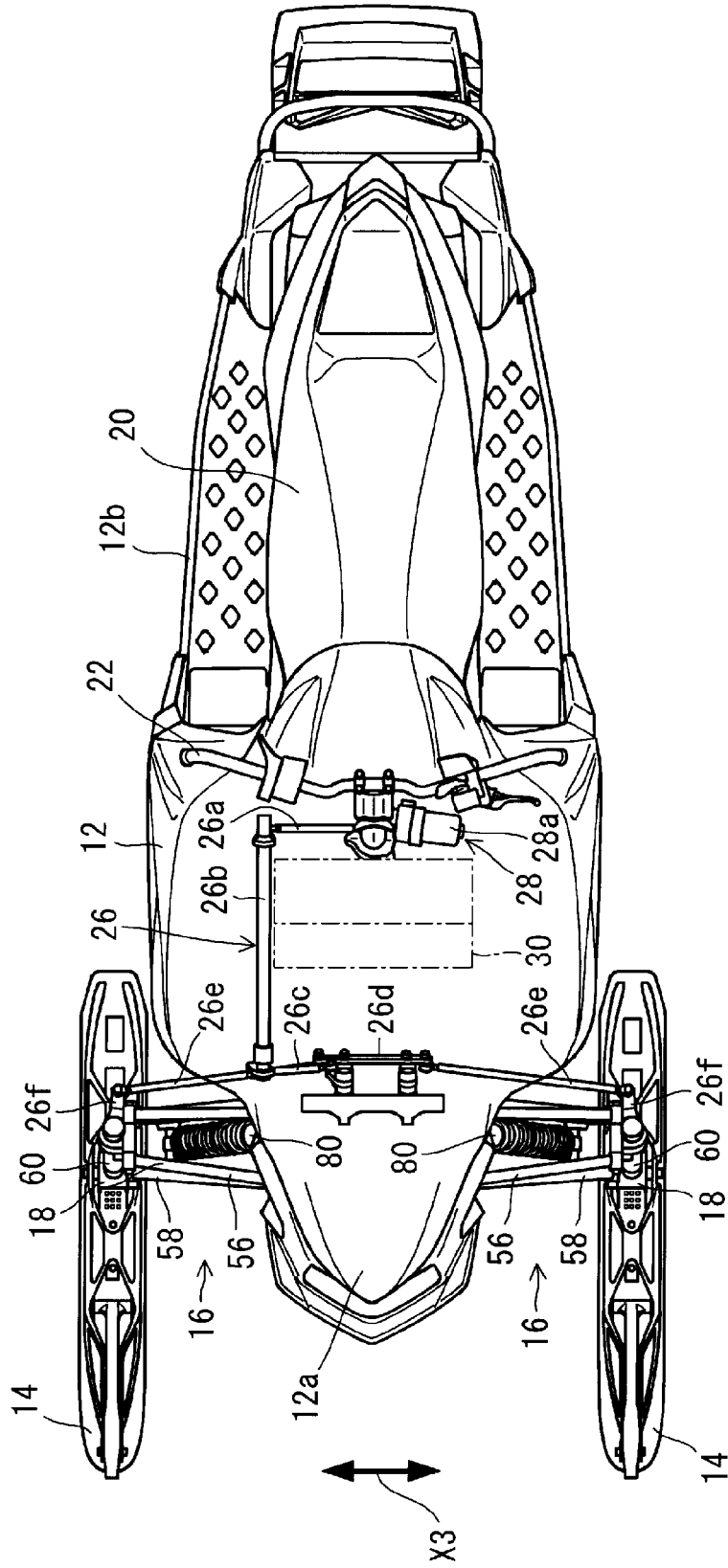

FIG. 3

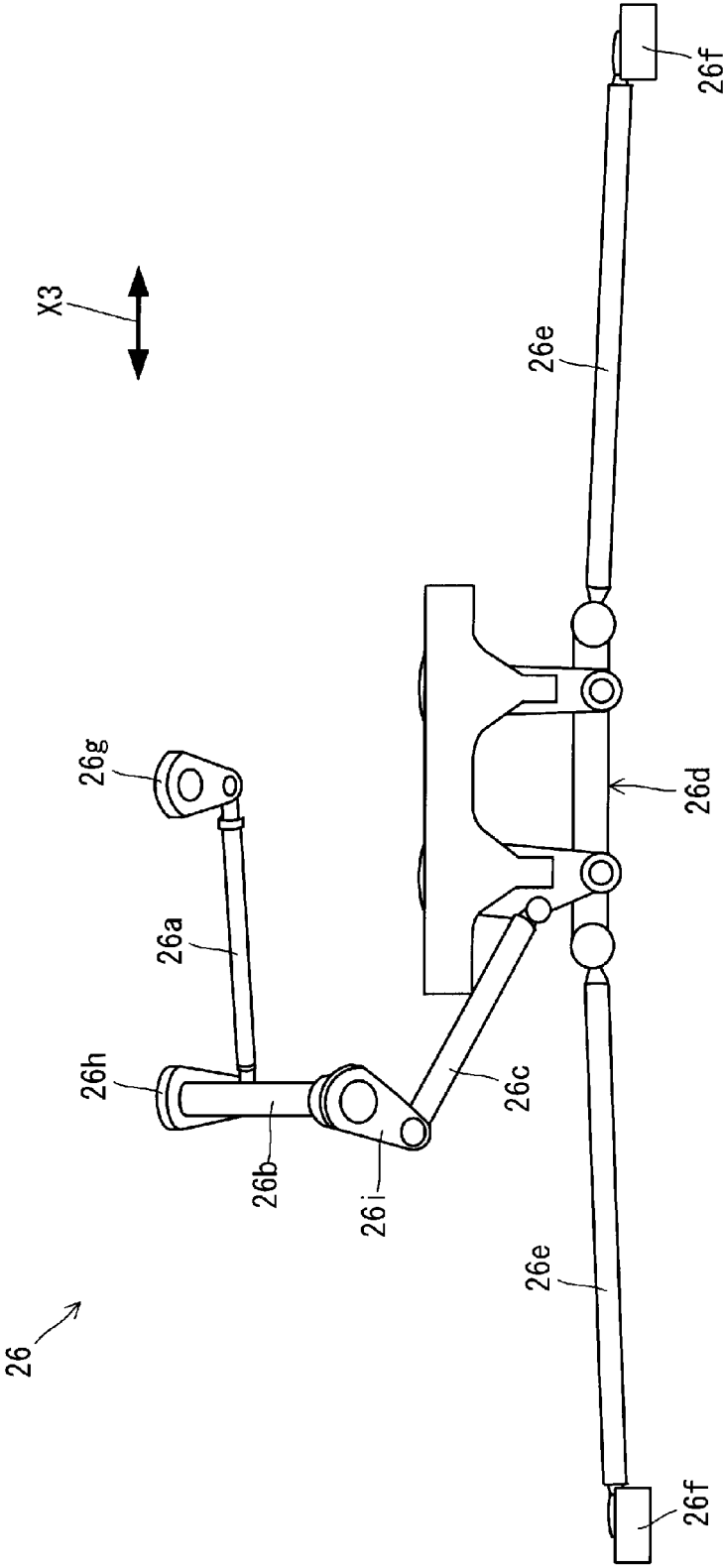

FIG. 4B

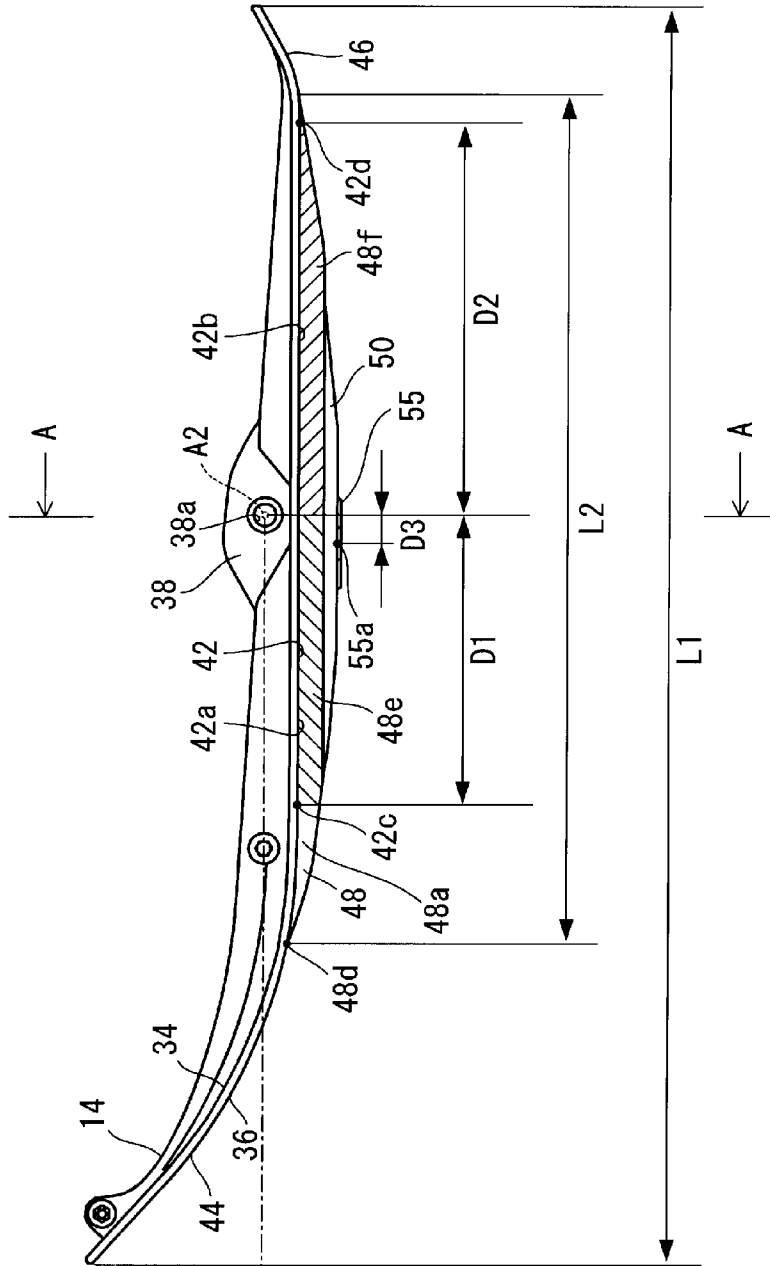

FIG. 4A

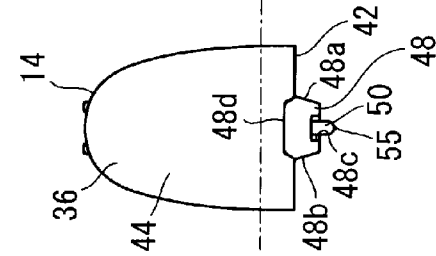

FIG. 5

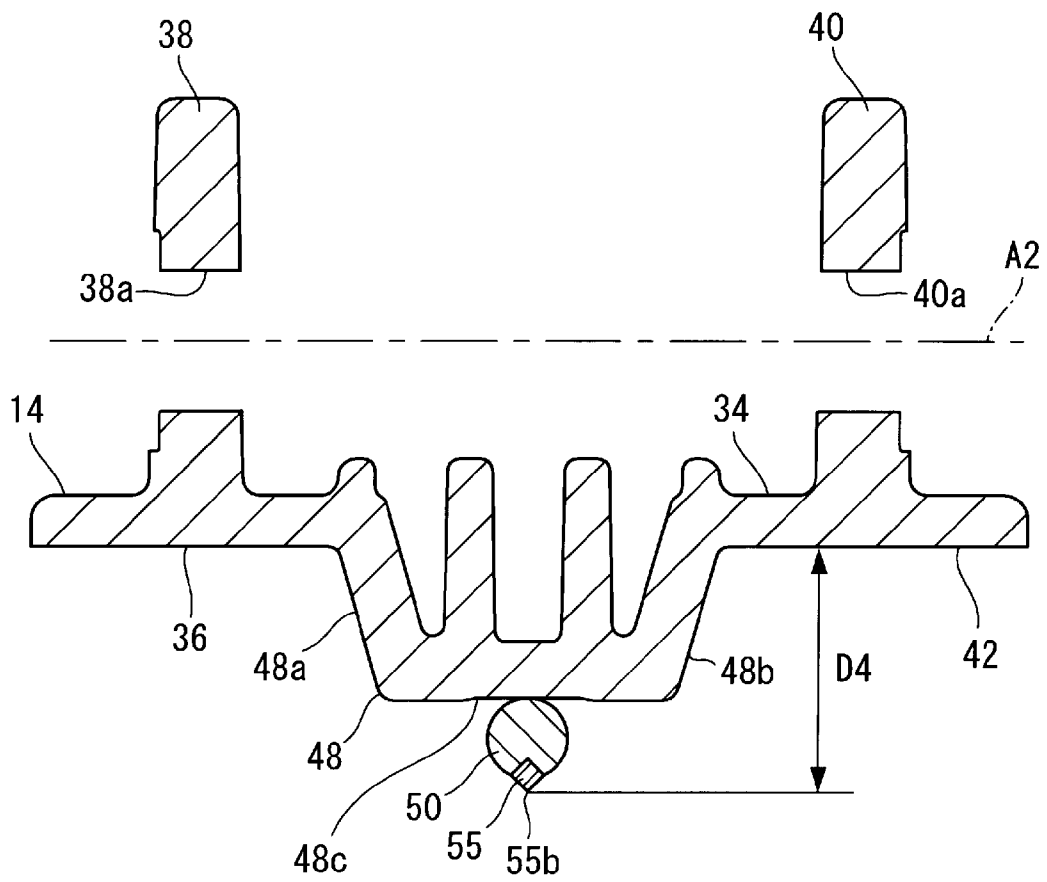

FIG. 6

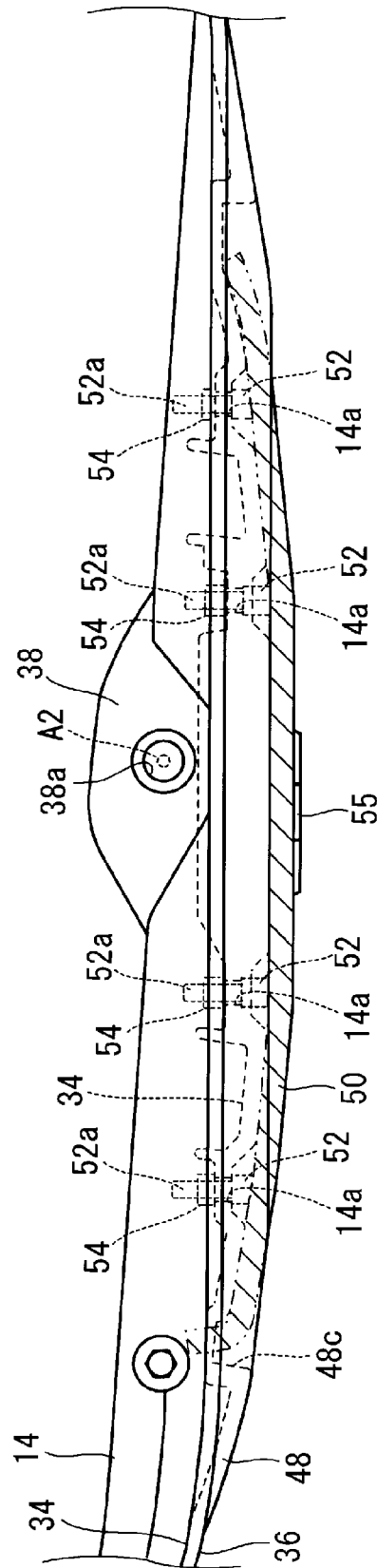

FIG. 7

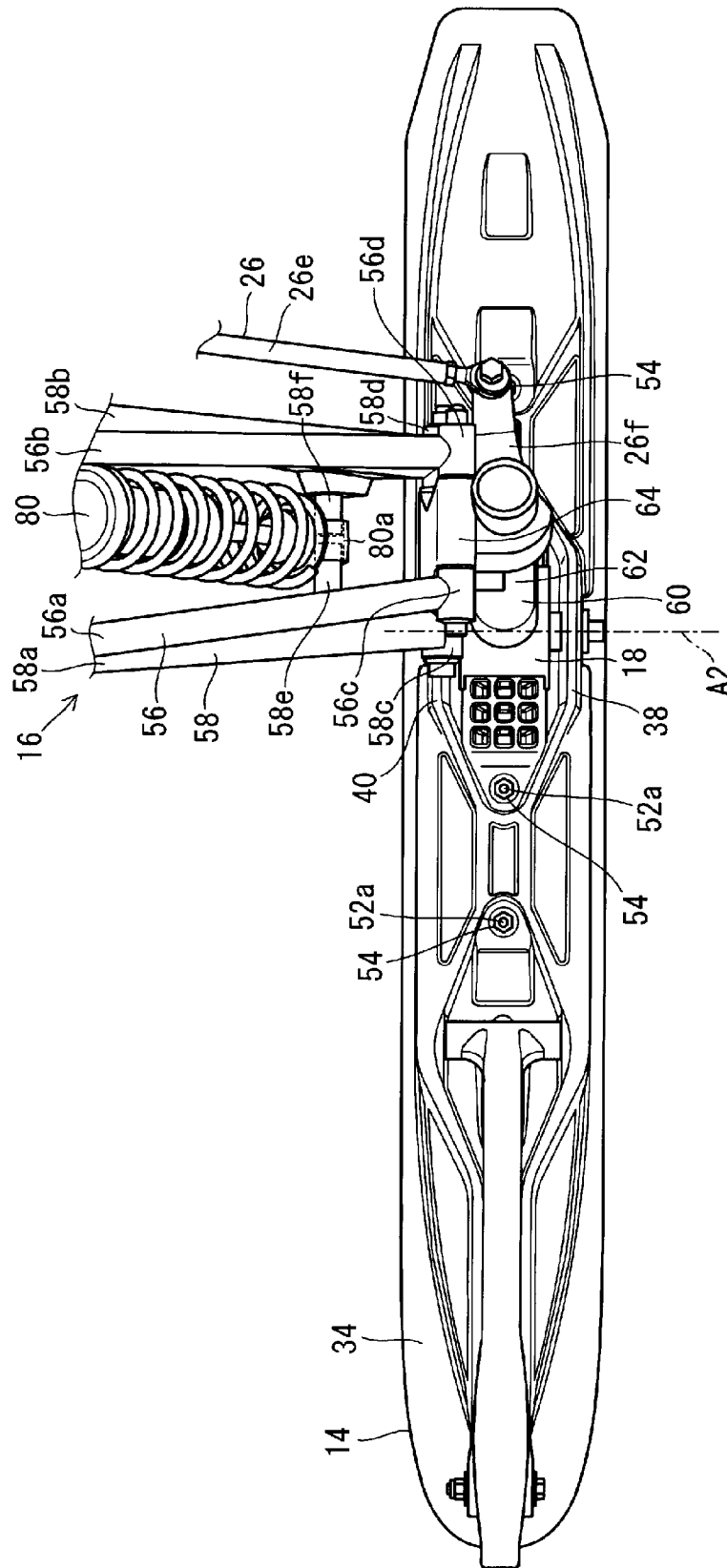

FIG. 8

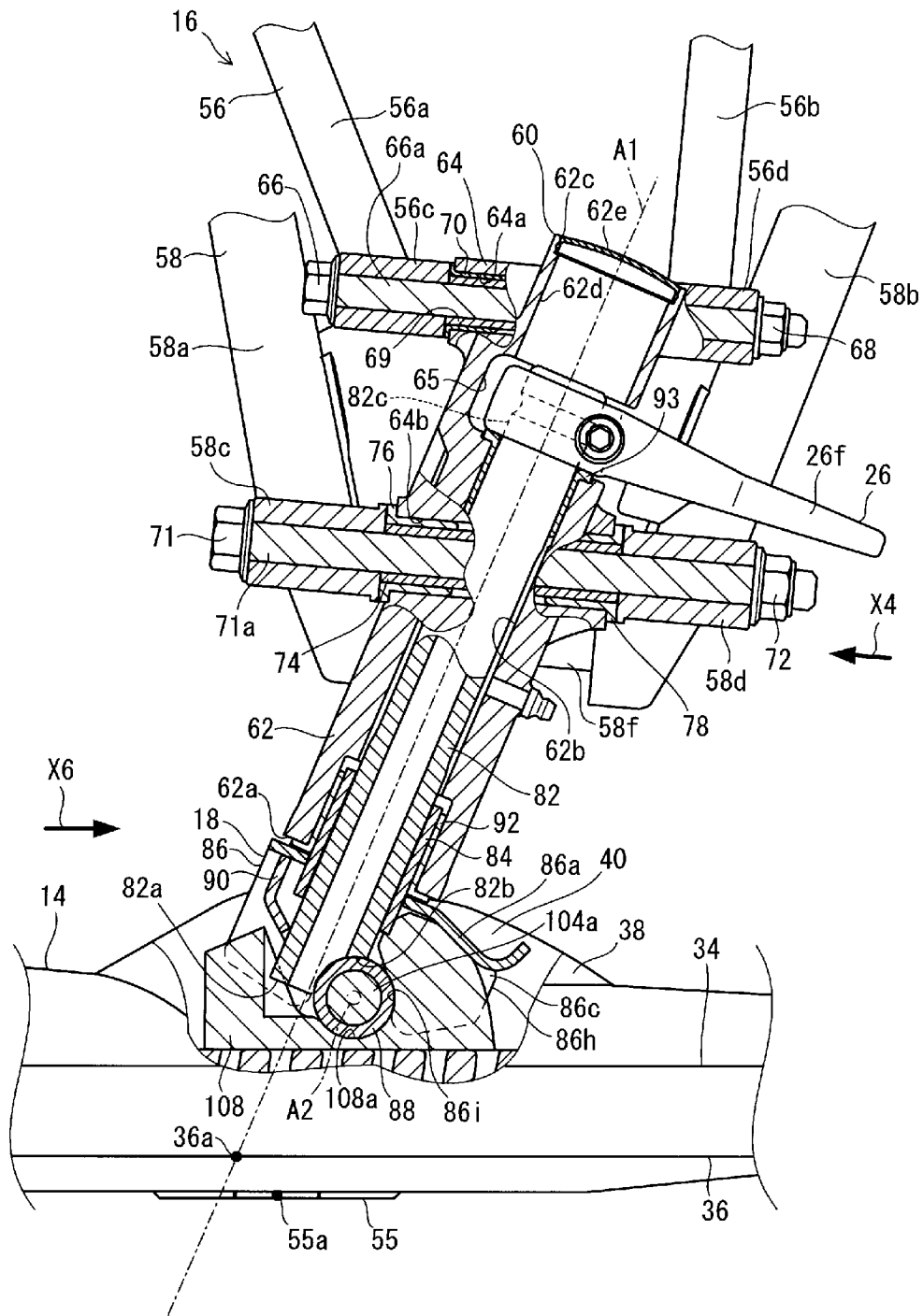

FIG. 9

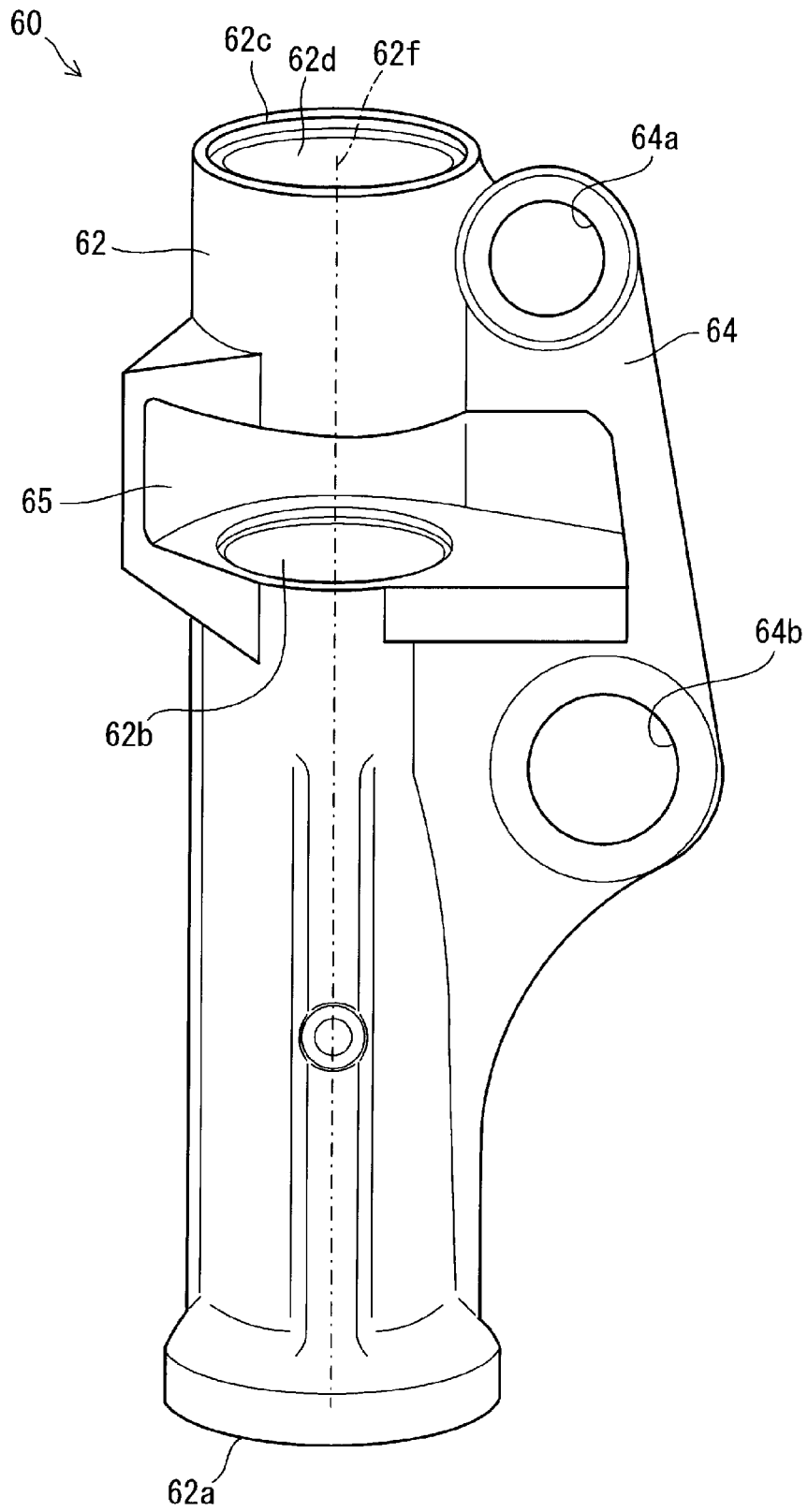

FIG. 10

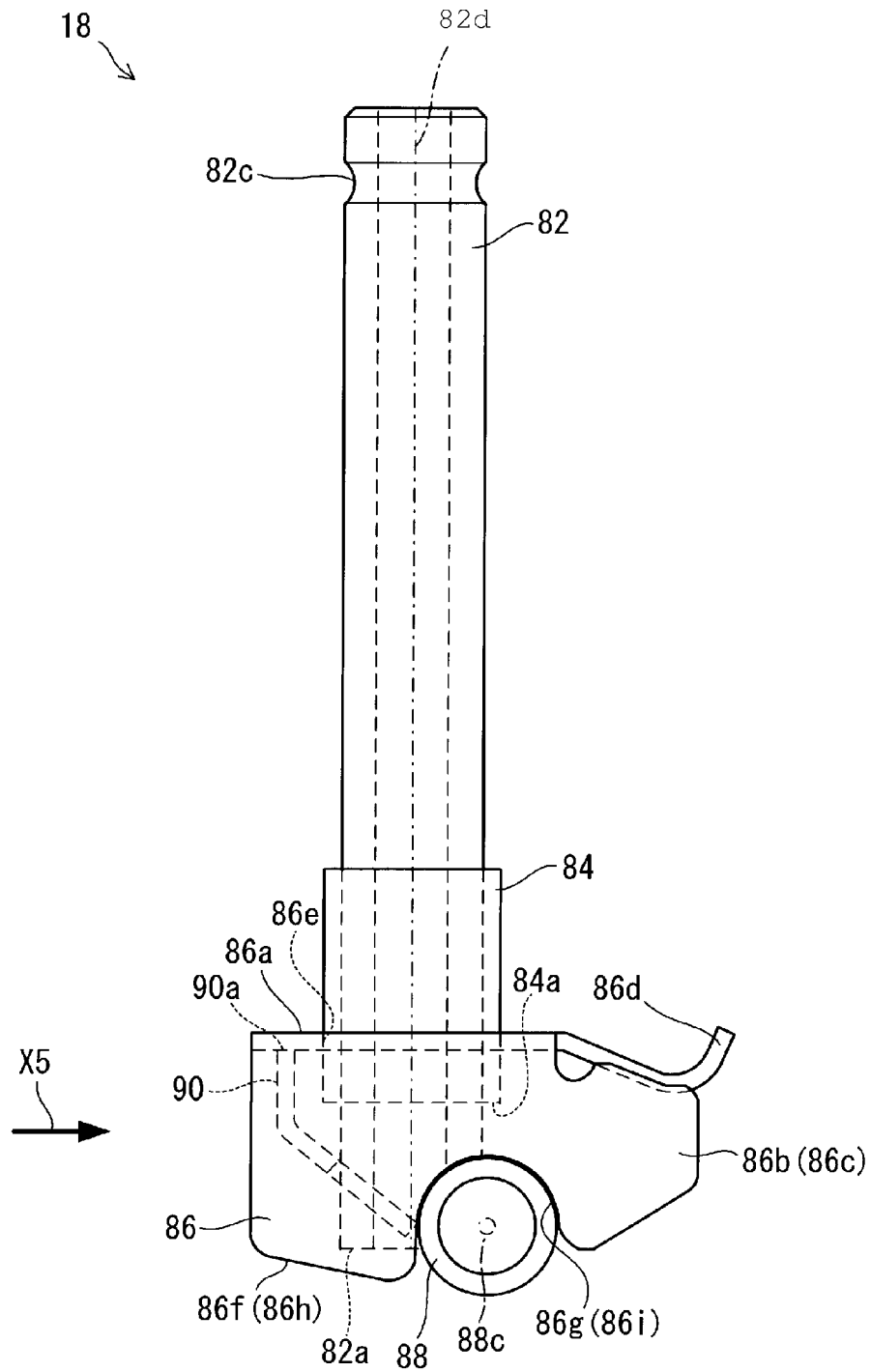

FIG. 11

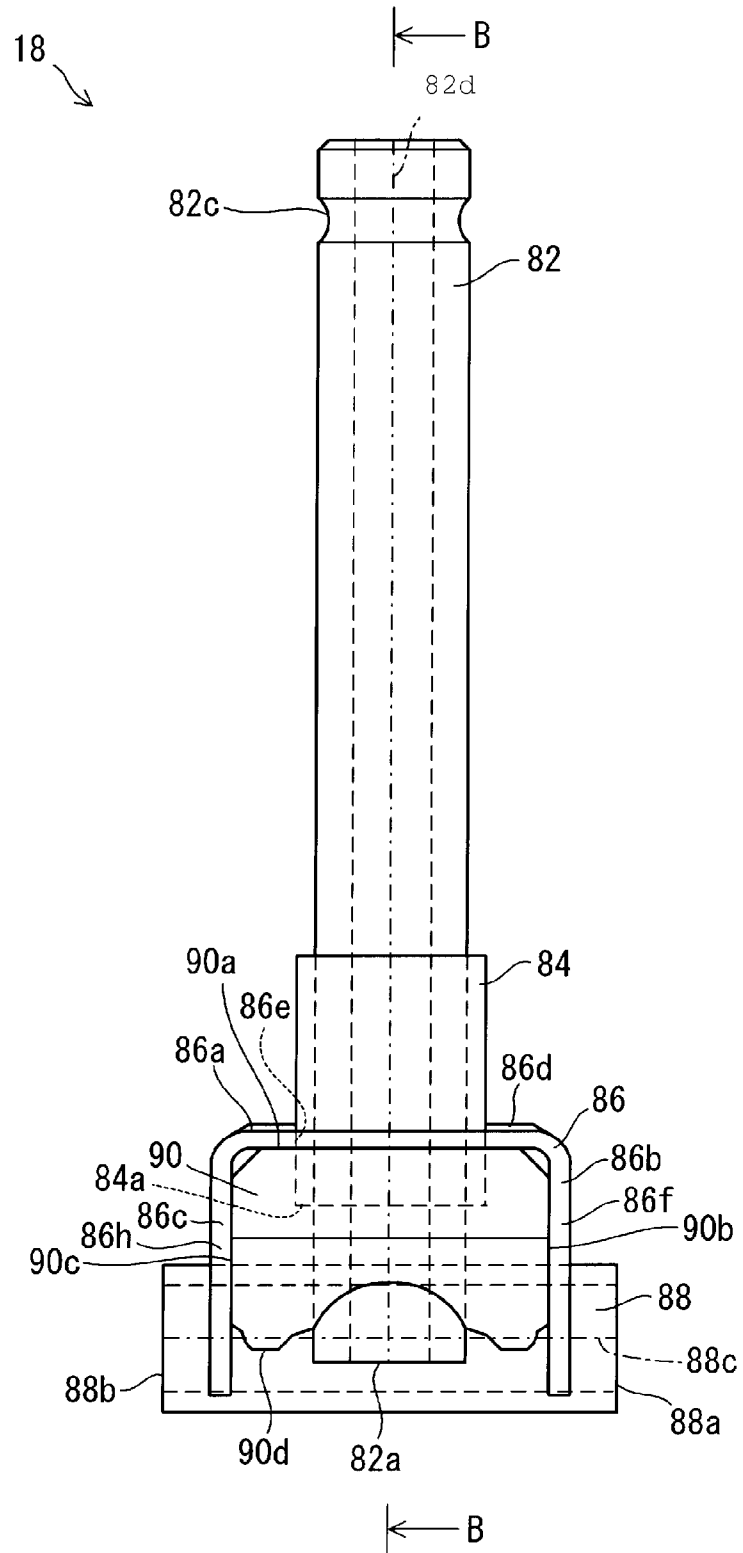

FIG. 12

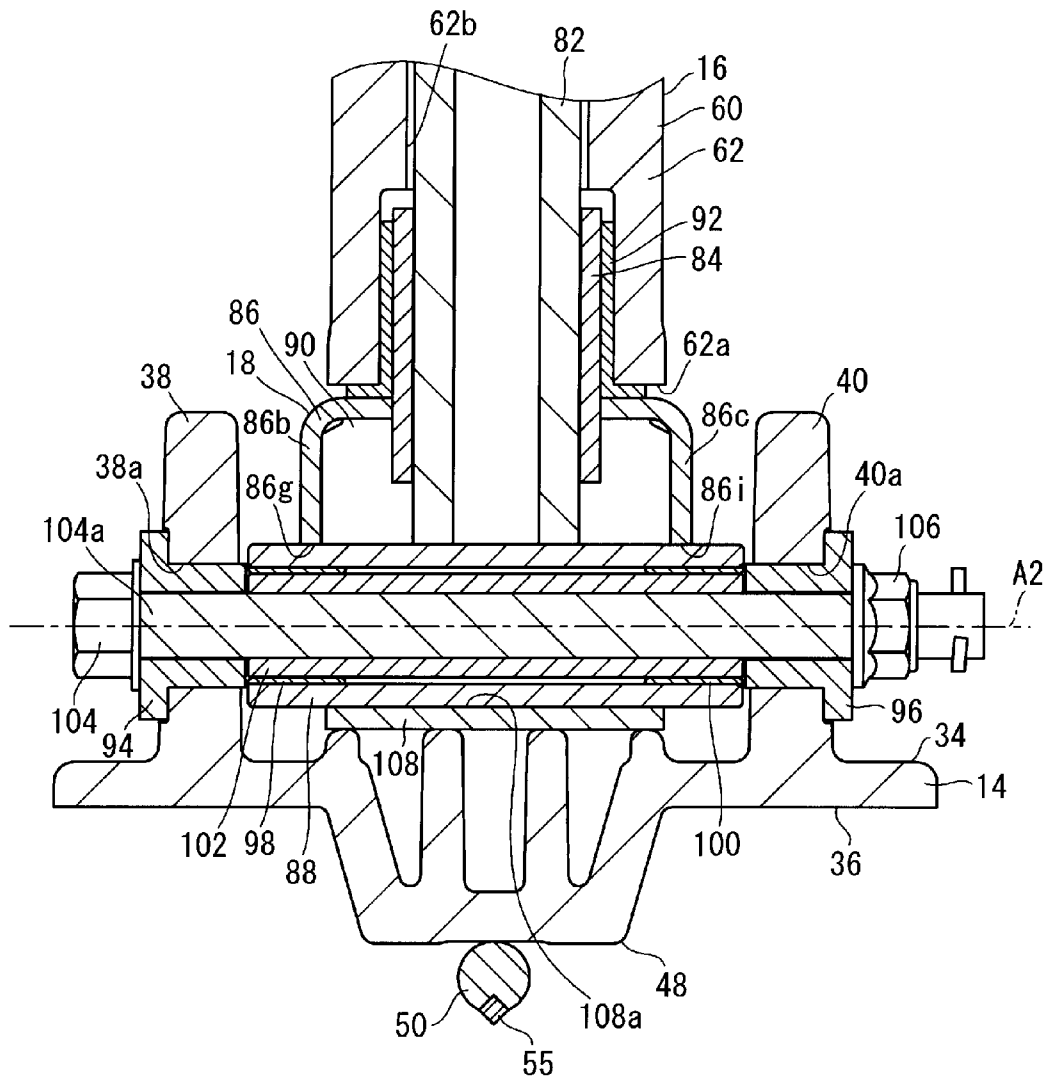

FIG. 13

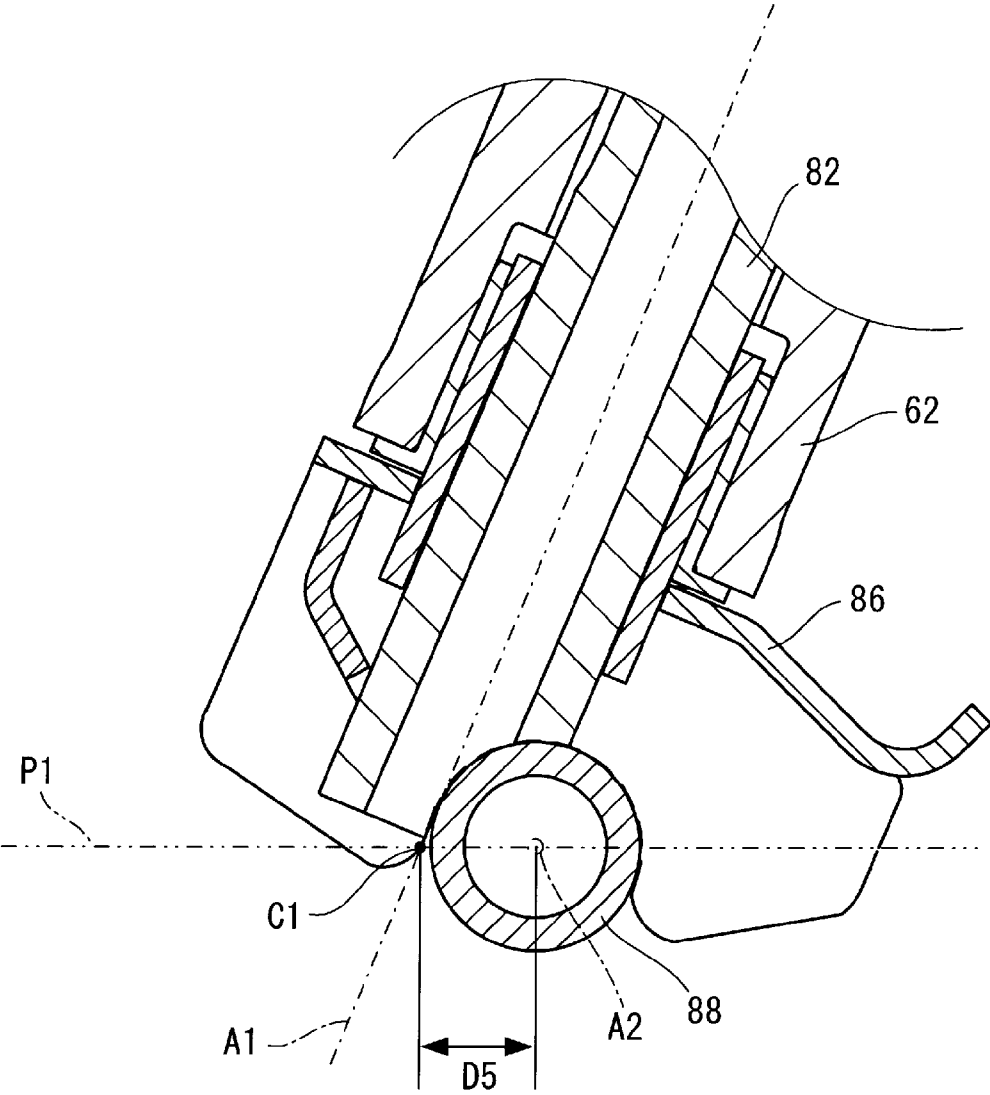

FIG. 14

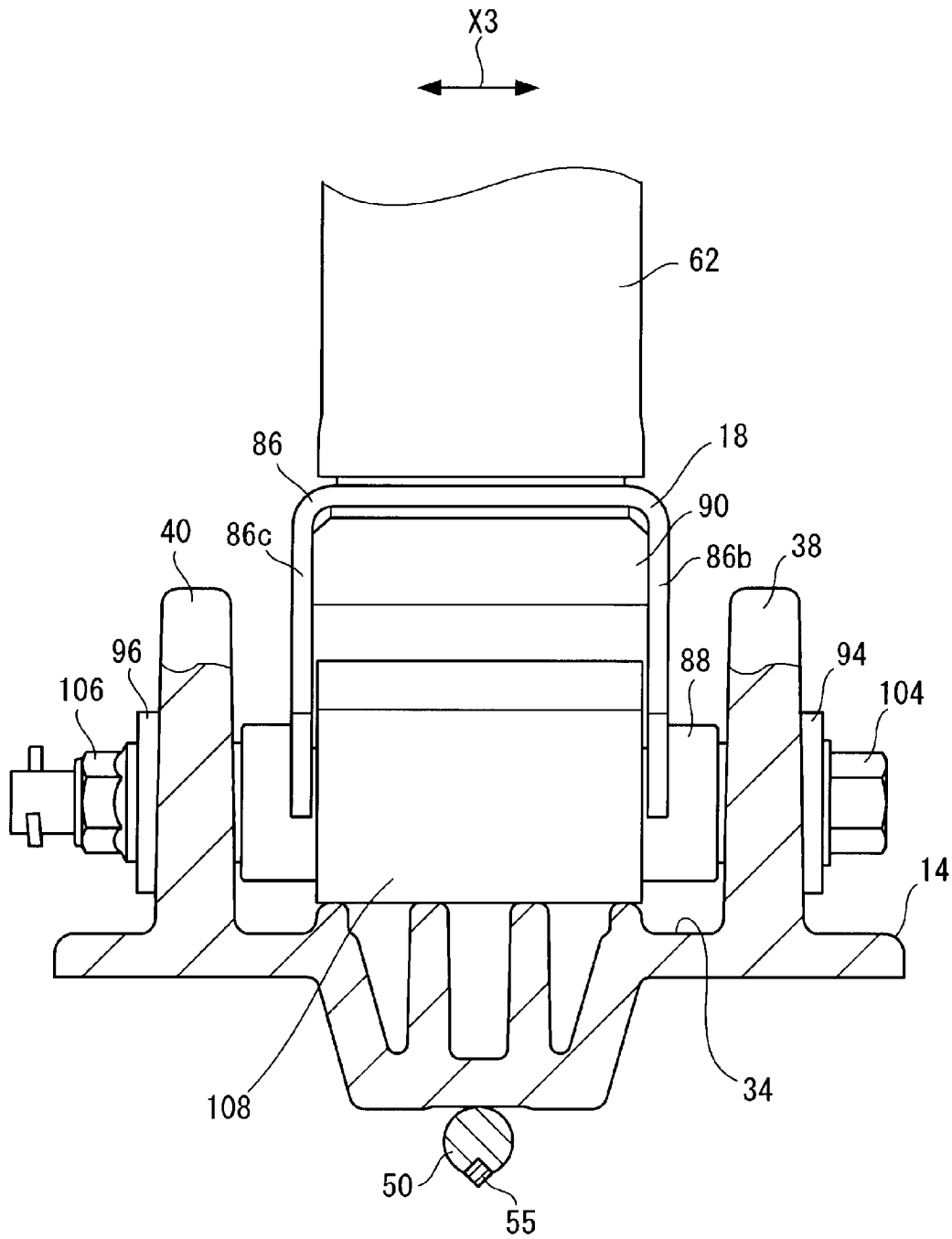
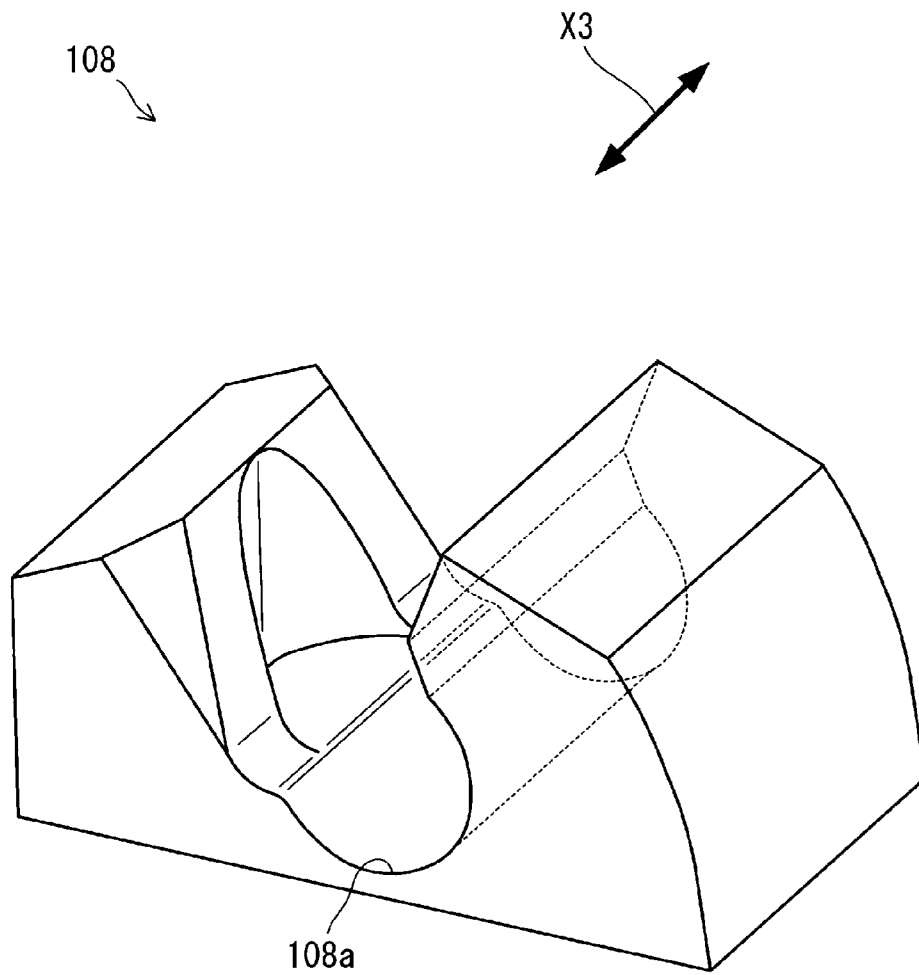

FIG. 15



1

## SNOWMOBILE INCLUDING SKIS WITH KEEL AND RUNNER

### BACKGROUND OF THE INVENTION

#### 1. Field of the Invention

The present invention relates to snowmobiles, and more specifically to a snowmobile equipped with a pair of skis.

#### 2. Description of the Related Art

Recently, snowmobiles equipped with four-stroke engines have been manufactured in consideration of the impact upon the environment. Exhaust gas from four-stroke engines is cleaner than from two-stroke engines. However, four-stroke engines are heavier than two-stroke engines, and for this reason, a snowmobile equipped with a four-stroke engine is heavier in a front portion of its body where the engine is mounted. In this case, the rider must use a greater force when operating the steering mechanism. Thus, in an attempt to reduce the force required for the rider to operate the steering mechanism, conventional proposals are made for snowmobiles to be equipped with power steering devices (see U.S. Patent Application Laid-Open 2009/0152036 A1, for example).

Meanwhile, in addition to caring for the environment, there is also demand for faster snowmobiles. In order to accomplish a comfortable ride on the snowmobile at high speeds, improvements are further desired for straight travel and for cornering characteristics.

### SUMMARY OF THE INVENTION

Therefore, preferred embodiments of the present invention provide a snowmobile which has improved characteristics in straight travel and cornering, without increasing a steering load.

According to a preferred embodiment of the present invention, a snowmobile preferably includes a body; a steering mechanism provided on the body; a steering shaft connected with the steering mechanism for associated operation with the steering mechanism; a power steering device provided in the steering shaft; a pair of skis; and a connecting section connecting the skis with the body and supporting the skis for pivotal movement in a horizontal direction about a first pivot axis in association with the steering shaft and for pivotal movement in the vertical direction about a second pivot axis which extends in a widthwise direction of the body. With the above arrangement, the first pivot axis is located at a more forward position than the second pivot axis in a horizontal plane which includes the second pivot axis. Further, each of the skis has, in its lower surface, a straight portion extending straightly, an approach portion ahead of the straight portion and curving upward, and a keel portion protruding downward to a lower position than the straight portion and the approach portion, wherein a horizontal distance between the second pivot axis and a rear end of the straight portion is longer than a horizontal distance between the second pivot axis and a fore end of the straight portion, and the keel portion has its fore end at a lower position than the second pivot axis, when the straight portion is horizontal.

In a preferred embodiment of the present invention, the rider's operation on the steering mechanism is transmitted to the skis via the steering shaft and the connecting section, and thus the pair of skis is pivoted about the first pivot axis in a horizontal direction. As a result, the snowmobile is steered.

In the above, according to the present preferred embodiment, when the straight portions in the skis' lower surfaces are horizontal, the horizontal distance between the rear end of

2

the straight portion and the second pivot axis is longer than the horizontal distance between the fore end of the straight portion and the second pivot axis. In this case, it is possible in the straight portion to ensure an area of contact between a rearward segment which is behind the second pivot axis and the snow surface. This makes it possible to improve a straight travel characteristic of the snowmobile. It should be noted that even if the straight portion has an extended rear segment behind the second pivot axis, the power steering device assists rotating operation of the steering shaft, thereby preventing the steering load from increasing.

Also, within the horizontal plane which includes the second pivot axis, the first pivot axis is located at a more forward position than the second pivot axis. Therefore, when the skis pivot in a horizontal direction, the pivot center of each lower surface in the skis is at a more forward position than the second pivot axis. In this case, when the steering mechanism is operated by a large steering angle (when the body makes a sharp turn), a portion of the ski's lower surface under the second pivot axis moves to outside of the first pivot axis with respect to the turning direction. Meanwhile, even if the ski pivots in the vertical direction, the portion of the ski's lower surface under the second pivot axis pivots very little in the vertical direction. Therefore, even when the body makes a sharp turn, it is possible to surely support the load from the body by the portion of the ski's lower surface under the second pivot axis. This reduces rolling of the body during cornering operations, i.e., this improves a cornering characteristic of the snowmobile. It should be noted that generally, in order to improve the cornering characteristic of a snowmobile, it is necessary to increase the length of a portion ahead of the second pivot axis in the ski. In this case, however, it becomes difficult to improve the straight travel characteristic. For this reason, conventionally, it has not been easy to improve both the straight travel characteristic and the cornering characteristic. On the contrary, according to the preferred embodiments of the present invention, it is possible to improve the cornering characteristic as described above, by an arrangement in which the first pivot axis is located at a more forward position than the second pivot axis within the horizontal plane which includes the second pivot axis. This eliminates the need for increasing the length of the portion ahead of the second pivot axis in the ski in order to improve the cornering characteristic, making it possible to improve both the straight travel characteristic and the cornering characteristic.

Also, when the straight portion of the lower surface in the ski is horizontal, the fore end of the keel portion is at a lower position than the second pivot axis. In other words, the keel portion is not provided in the approach portion on its fore side (above side) of the ski. In this case, even if a rut, etc., is already formed on the snow surface, the keel portion is not easily set in the rut, etc., when the approach portion makes contact with the snow surface. This provides easy steering of the snowmobile, and provides a comfortable ride on the snowmobile.

Preferably, the keel portion includes a side surface, and the side surface has a region of a larger area defined by the second pivot axis and the rear end of the straight portion than another region defined by the second pivot axis and the fore end of the straight portion, when the straight portion is horizontal. In this case, it is possible to ensure a snow contact area in a region behind the second pivot axis and ahead of the rear end of the straight portion, in the side surface of the keel portion. This makes it possible to further improve the straight travel characteristic of the snowmobile. It should be noted that the region defined by the second pivot axis and the rear end of the straight portion includes a region which is behind the second

pivot axis and is ahead of the rear end of the straight portion; further, the region defined by the second pivot axis and the fore end of the straight portion includes a region which is ahead of the second pivot axis and is behind the fore end of the straight portion.

Preferably, the snowmobile further includes a pair of runners, each runner being provided in the lower surface of the ski; and a pair of chip members, each chip member being provided in the runner and protruding downward to a lower position than the runner. With this arrangement, each of the chip members has a center in a fore-aft direction located at a more forward position than the second pivot axis. In this case, it is possible to make the center of the chip member close to the pivot center in the lower surface of the ski. This makes it possible to further improve the cornering characteristic of the snowmobile.

Preferably, the snowmobile is equipped with a four-stroke engine in a front portion of the body as a power source for travel. In this case, the exhaust gas is cleaner and the snowmobile's straight travel and cornering characteristics are improved.

It should be noted that the expression that the skis pivot in a horizontal direction does not only mean that the skis pivot in a horizontal direction but also includes cases where the skis pivot obliquely with respect to the horizontal plane.

Other elements, features, steps, characteristics and advantages of the present invention will become more apparent from the following detailed description of the preferred embodiments with reference to the attached drawings.

#### BRIEF DESCRIPTION OF THE DRAWINGS

FIG. 1 is a side view showing a snowmobile according to a preferred embodiment of the present invention.

FIG. 2 is a plan view of the snowmobile in FIG. 1.

FIG. 3 is a front view showing a link mechanism.

FIG. 4A and FIG. 4B are diagrams for describing skis in detail. FIG. 4A is a front view of the ski whereas FIG. 4B is a side view thereof.

FIG. 5 is an end view taken along lines A-A in FIG. 4B.

FIG. 6 is an enlarged side view of the ski.

FIG. 7 is an enlarged plan view showing a relationship between the ski, an arm mechanism, and a column assembly.

FIG. 8 is an enlarged side view showing a relationship between the ski, the arm mechanism, and the column assembly.

FIG. 9 is a rear view showing a steering knuckle.

FIG. 10 is a side view showing a column assembly.

FIG. 11 is a front view showing the column assembly.

FIG. 12 is a sectional view showing how the ski, the column assembly, and the steering knuckle are connected.

FIG. 13 is a diagram showing a positional relationship between a first pivot axis and a second pivot axis.

FIG. 14 is an explanatory drawing which shows the ski, the column assembly, and the steering knuckle.

FIG. 15 is a perspective view showing a stopper member.

#### DETAILED DESCRIPTION OF THE PREFERRED EMBODIMENTS

Hereinafter, preferred embodiments of the present invention will be described with reference to the drawings.

FIG. 1 is a side view of a snowmobile 10 according to a preferred embodiment of the present invention whereas FIG. 2 is a plan view of the snowmobile 10 in FIG. 1. In FIG. 1 and FIG. 2, the snowmobile 10 is shown as a conceptual drawing so that its internal structure will be easily understood. Also, in

the description hereinafter, a direction indicated by Arrow X1 in FIG. 1 (direction in which the snowmobile 10 travels forward) will be called a forward direction, a direction indicated by Arrow X2 will be called a rearward direction, and a direction indicated by Arrow X3 in FIG. 2 will be called a widthwise direction.

Referring to FIG. 1 and FIG. 2, the snowmobile 10 includes a body 12 and a pair of skis 14. The skis 14 are laid in parallel to each other, extending in the fore-aft direction so as to sandwich the body 12. The body 12 has a front portion 12a, where a pair of arm mechanisms 16 are provided, extending in the widthwise direction of the body 12. Each arm mechanism 16 is linked to one of the skis 14 via a column assembly 18. Thus, the front portion 12a of the body 12 is supported by the skis 14. The skis 14, the arm mechanisms 16, and the column assemblies 18 will be described in detail below.

Referring to FIG. 1, the body 12 has a rear portion 12b, on top of which a seat 20 is provided. In the body 12, ahead of the seat 20, a steering mechanism 22 and a steering shaft 24 are arranged to pivot. The steering shaft 24 is connected with the steering mechanism 22 so as to move in association with the steering mechanism 22.

A link mechanism 26 is provided in the body 12 so that the skis 14 are moved in association with the steering shaft 24. FIG. 3 is a front view which shows the link mechanism 26. Referring to FIG. 2 and FIG. 3, the link mechanism 26 includes a first rod 26a, a second rod 26b, a third rod 26c, a transfer portion 26d, a pair of fourth rods 26e and a pair of pivot members 26f. Referring to FIG. 1 and FIG. 3, the first rod 26a (see FIG. 3) is connected with the steering shaft 24 (see FIG. 1) via a connecting member 26g. Referring to FIG. 3, the first rod 26a and the second rod 26b are connected with each other via a connecting member 26h. The second rod 26b and the third rod 26c are connected with each other via a connecting member 26i. The third rod 26c is connected with the transfer member 26d. The fourth rods 26e are connected with the transfer member 26d. Each of the pivot members 26f is connected with a corresponding one of the fourth rods 26e. A torque received by the steering shaft 24 (see FIG. 1) is transmitted via the first rod 26a, the second rod 26b, and the third rod 26c to the transfer portion 26d. Based on the force transmitted from the third rod 26c, the transfer portion 26d moves the pair of fourth rods 26e in and out in the widthwise direction (Arrow X3 direction). The in-out movement of the fourth rods 26e is transmitted by the pivot members 26f to respective shaft members 82 (see FIG. 8), to be described below, of the column assemblies 18. Thus, the shaft member 82 (see FIG. 8) rotates about a first pivot axis A1 to be described below (see FIG. 1 and FIG. 8), pivoting the pair of skis 14 in a horizontal direction. As a result, the snowmobile 10 is steered.

Referring to FIG. 1, the steering shaft 24 is connected with a power steering device 28 which has a motor 28a. The power steering device 28 assists the rotating movement of the steering shaft 24 using a driving force generated by the motor 28a.

Referring to FIG. 1 and FIG. 2, an engine 30 is mounted in the front portion 12a of the body 12, at a widthwise center position. It should be noted here that FIG. 2 shows the engine 30 in a simplified form so that the figure will not be too complicated. The engine 30 is preferably a four-cylinder, four-stroke engine with a displacement of about 1,000 cc, for example.

Referring to FIG. 1, a track system 32 is provided in the rear portion 12b of the body 12, on a lower side thereof. The rear portion 12b of the body 12 is supported by the track system 32. The track system 32 includes a track belt 32a. Power from the engine 30 is transmitted by an unillustrated transmission

5

mechanism to the track belt **32a**, whereby the track belt **32a** is driven and the snowmobile **10** travels forward.

Hereinafter, detailed description will be made of a configuration of the skis **14**, the arm mechanisms **16**, and the column assemblies **18**.

First, the skis **14** will be described. FIG. 4A and FIG. 4B are diagrams for describing the skis **14** in detail. FIG. 4A is a front view of the ski **14**, FIG. 4B is a side view thereof, and FIG. 5 is an end view taken along lines A-A in FIG. 4B. FIG. 6 is an enlarged side view of the ski **14**. FIG. 7 is an enlarged plan view which shows a relationship between the ski **14**, the arm mechanism **16**, and the column assembly **18**.

Referring to FIG. 4A, FIG. 4B, FIG. 5, and FIG. 6, the ski **14** has an upper surface **34** and a lower surface **36**. Referring to FIG. 4B, FIG. 5, FIG. 6 and FIG. 7, the upper surface **34** includes a pair of upward protruding side wall portions **38**, **40** (FIG. 4B and FIG. 6 show only the side wall portion **38**). The side wall portions **38**, **40** are substantially parallel to each other, and are substantially parallel with respect to a longitudinal direction of the ski **14**. Referring to FIG. 5, the side wall portion **38** has a through-hole **38a** and the side wall portion **40** has a through-hole **40a** opposed to the through-hole **38a**. The center of the through-hole **38a** and that of the through-hole **40a** are on a second pivot axis **A2** which extends parallel or substantially parallel with respect to the widthwise direction of the ski **14** (the body **12**). The second pivot axis **A2** will be described below.

Referring to FIG. 4A, FIG. 4B, and FIG. 5, the lower surface **36** of the ski **14** has a straight portion **42** extending straightly in a horizontal direction; an approach portion **44** (see FIG. 4A and FIG. 4B), which is a portion ahead of the straight portion **42**, curving upward to extend beyond the second pivot axis **A2**; a rear portion **46** (see FIG. 4B), which is a portion curving upward behind the straight portion **42**; and a keel portion **48** protruding downward to a lower position than the straight portion **42**. It should be noted here that up, down, fore and aft in describing the ski **14** are determined based on perceptions of up, down, fore and aft when the straight portion **42** is horizontal.

Referring to FIG. 4B, the straight portion **42** includes a first straight portion **42a**, which is a portion ahead of the second pivot axis **A2**; and a second straight portion **42b**, which is a portion behind the second pivot axis **A2**. When the straight portion **42** is horizontal, a horizontal distance **D1** between a fore end **42c** of the first straight portion **42a** and the second pivot axis **A2** is shorter than a horizontal distance **D2** between a rear end **42d** of the second straight portion **42b** and the second pivot axis **A2**. The distance **D2** is preferably approximately 1.3 times the distance **D1**, for example. The distance **D1** can be about 240 mm, for example, whereas the distance **D2** can be about 320 mm, for example. It should be noted here that the lower surface **36** preferably has a horizontal length **L1** of about 1040 mm, for example, whereas the keel portion **48** preferably has a horizontal length **L2** of about 705 mm, for example.

Referring to FIG. 4A, the keel portion **48** has a substantially symmetric shape in the right-left direction. The keel portion **48** has downward extending side surfaces **48a**, **48b** (see FIG. 4A and FIG. 5) and a recess **48c** (see FIG. 4A, FIG. 5 and FIG. 6) recessed upward along a widthwise center portion. Referring to FIG. 4A and FIG. 4B, the keel portion **48** has a fore end **48d** located at a lower position than the second pivot axis **A2**. In the side surface **48a** of the keel portion **48**, a region **48e** under the first straight portion **42a** (region ahead of the second pivot axis **A2** and behind the fore end **42c** of the straight portion **42**, i.e., a region hatched with a rightward-rising pattern) has a smaller area than a region **48f** under the

6

second straight portion **42b** (region behind than the second pivot axis **A2** and ahead of the rear end **42d** of the straight portion **42**, i.e., a region hatched with a leftward-rising pattern). Likewise, in the side surface **48b** of the keel portion **48** (see FIG. 4A), a region (not illustrated) under the first straight portion **42a** has a smaller area than a region (not illustrated) under the second straight portion **42b**.

Referring to FIG. 6, the recess **48c** is fitted with a runner **50**. FIG. 6 shows the runner **50** with hatches so that the shape of the runner **50** can be understood easily. In the runner **50**, on an upper side thereof, four bolts **52** are fixed. Each bolt **52** has a shank **52a**, which is inserted into one of four through-holes **14a** in the ski **14**. Referring to FIG. 6 and FIG. 7, each shank **52a** is threaded by a nut **54** from the upper surface **34** side of the ski **14** (FIG. 7 shows two shanks **52a** and three nuts **54** only). Thus, the runner **50** is fixed to the ski **14**.

Referring to FIG. 4B and FIG. 5, in the runner **50**, a chip member **55**, which has a diamond-shaped section is fixed at a substantially center portion in the fore-aft direction (longitudinal direction). Referring to FIG. 5, the chip member **55** has its upper portion buried into the runner **50**, and a lower portion protruding downward from the runner **50**. Referring to FIG. 4B, the chip member **55** has a center **55a** in the fore-aft direction (longitudinal direction), which is located at a more forward position than the second pivot axis **A2**. When the straight portion **42** is horizontal, a horizontal distance **D3** between the center **55a** and the second pivot axis **A2** preferably is about 24 mm, for example. The chip member **55** is made of a material which has a greater hardness than the runner **50** (examples include alloys containing tungsten, cobalt or the like). Referring to FIG. 5, when the straight portion **42** is horizontal, a vertical distance **D4** between the straight portion **42** and a lower end **55b** of the chip member **55** preferably is about 33 mm, for example.

Next, the arm mechanism **16** will be described. Referring to FIG. 1, FIG. 2, FIG. 7, and FIG. 8, each arm mechanism **16** includes an upper arm mechanism **56**, a lower arm mechanism **58**, and a steering knuckle **60**. Referring to FIG. 1, the upper arm mechanism **56** and the lower arm mechanism **58** are pivotably attached to the body **12**.

Referring to FIG. 7 and FIG. 8, the upper arm mechanism **56** includes an arm **56a** on a forward side and an arm **56b** which is on a more rearward side than the arm **56a**. The arm **56a** has an end with a cylindrical portion **56c** and the arm **56b** has an end with a cylindrical portion **56d**. The lower arm mechanism **58** includes an arm **58a** on a forward side and an arm **58b** which is on a more rearward side than the arm **58a**. The arm **58a** has an end with a cylindrical portion **58c** and the arm **58b** has an end with a cylindrical portion **58d**.

FIG. 9 is a rear view of the steering knuckle **60** (as viewed in Arrow **X4** direction in FIG. 8). Referring to FIG. 9, the steering knuckle **60** has a generally cylindrical main body portion **62** extending in the vertical direction; a connection portion **64** extending laterally from the main body portion **62**; and a recess **65** which is formed in the main body portion **62** as well as in the connection portion **64** and which opens rearward. Referring to FIG. 8 and FIG. 9, in the main body portion **62**, a communication hole **62b** provides communication between a lower end **62a** and the recess **65**; and a communication hole **62d** provides communication between an upper end **62c** and the recess **65**. Referring to FIG. 9, the connection portion **64** has an upper portion with a through-hole **64a** penetrating in the fore-aft direction (depth direction in FIG. 9). The connection portion **64** has a lower portion with through-hole **64b** penetrating in the fore-aft direction (depth direction FIG. 9). Referring to FIG. 7, when the steering knuckle **60** is assembled into the arm mechanism **16**, the

connection portion **64** is located on the upper arm mechanism **56** side (the lower arm mechanism **58** side).

Referring to FIG. **8**, in the upper end **62c** of the main body portion **62**, a cap **62e** blocks the communication hole **62d**. A shank **66a** (see FIG. **8**) of a bolt **66** (see FIG. **8**) is rotatably inserted through the cylindrical portion **56c** (see FIG. **7** and FIG. **8**) of the arm **56a** (see FIG. **7** and FIG. **8**); the through-hole **64a** (see FIG. **8** and FIG. **9**) of the connection portion **64** (see FIG. **7** through FIG. **9**); and the cylindrical portion **56d** (see FIG. **7** and FIG. **8**) of the arm **56b** (see FIG. **7** and FIG. **8**). Referring to FIG. **8**, the shank **66a** has its tip portion threaded by a nut **68**. Thus, the upper arm mechanism **56** is pivotably attached to the steering knuckle **60**. It should be noted here that inside the through-hole **64a**, the shank **66a** has its outer circumferential surface surrounded by a cylindrical collar **69**. The collar **69** has its outer circumferential surface surrounded by a generally cylindrical bushing **70** (see FIG. **8**) between the cylindrical portion **56c** (see FIG. **7** and FIG. **8**) and the connection portion **64** (see FIG. **7** through FIG. **9**). Likewise, the outer circumferential surface of the collar **69** (see FIG. **8**) is also surrounded by a bushing (not illustrated) between the cylindrical portion **56d** (see FIG. **7** and FIG. **8**) and the connection portion **64** (see FIG. **7** through FIG. **9**).

A shank **71a** (see FIG. **8**) of a bolt **71** (see FIG. **8**) is rotatably inserted through a cylindrical portion **58c** (see FIG. **7** and FIG. **8**) of the arm **58a** (see FIG. **7** and FIG. **8**), the through-hole **64b** (see FIG. **8** and FIG. **9**) of the connection portion **64** (see FIG. **7** through FIG. **9**), and a cylindrical portion **58d** (see FIG. **7** and FIG. **8**) of the arm **58b** (see FIG. **7** and FIG. **8**). Referring to FIG. **8**, the shank **71a** has its tip portion threaded by a nut **72**. Thus, the lower arm mechanism **58** is pivotably fixed to the steering knuckle **60**. Inside the through-hole **64b**, the shank **71a** has its outer circumferential surface surrounded by a cylindrical collar **74**. The collar **74** has its outer circumferential surface surrounded by a generally cylindrical bushing **76** (see FIG. **8**) between the cylindrical portion **58c** (see FIG. **7** and FIG. **8**) and the connection portion **64** (see FIG. **7** through FIG. **9**) and also surrounded by a generally cylindrical bushing **78** (see FIG. **8**) between the cylindrical portion **58d** (see FIG. **7** and FIG. **8**) and the connection portion **64** (see FIG. **7** through FIG. **9**).

Referring to FIG. **7**, the arm **58a** is provided with a cylindrical projection **58e** projecting toward the arm **58b** and the arm **58b** is provided with a cylindrical projection **58f** projecting toward the arm **58a**. The projection **58e** and the projection **58f** oppose each other with a space in between. A shock absorber **80** has an annular fitting **80a** at its lower end and an annular fitting **80b** (see FIG. **1**) at its upper end. The fitting **80a** of the shock absorber **80** is rotatably attached to the projections **58e**, **58f**. Likewise, referring to FIG. **1**, the fitting **80b** of the shock absorber **80** is rotatably attached to an unillustrated frame of the body **12**. As a result of these, the shock absorber **80** is pivotable with respect to the body **12** and the arm mechanism **16**.

Referring to FIG. **7** and FIG. **8**, the steering knuckle **60** is connected with the ski **14** via the column assembly **18**. FIG. **10** is a side view of the column assembly **18** whereas FIG. **11** is a front view of the column assembly **18** (when the column assembly **18** is viewed in Arrow X5 direction in FIG. **10**). The section of the column assembly **18** shown in FIG. **8** is a sectional view taken along lines B-B in FIG. **11**.

Referring to FIG. **10** and FIG. **11**, the column assembly **18** includes a cylindrical shaft member **82**, a cylindrical adjustment member **84**, a restriction member **86** which has an inverted U-shape in a front view, a cylindrical connection member **88** and a plate reinforcing member **90**.

The shaft member **82** is inserted through the adjustment member **84**. The shaft member **82** has a lower end **82a**, which protrudes downward from the adjustment member **84**. The shaft member **82** and the adjustment member **84** are fixed to each other by welding, for example. Referring to FIG. **8**, a curved portion **82b**, which curves upward substantially in an arc shape as in a side view, is formed on a rear side in the lower end **82a** of the shaft member **82**.

Referring to FIG. **10** and FIG. **11**, the restriction member **86** includes a ceiling portion **86a**, a side wall portion **86b**, and a side wall portion **86c** (see FIG. **11**). The ceiling portion **86a** has a gently curving rear portion **86d** and a through-hole **86e**. The shaft member **82** and the adjustment member **84** are inserted through the through-hole **86e**. The adjustment member **84** has a lower end **84a**, which is located downward from the ceiling portion **86a**. The adjustment member **84** and the ceiling portion **86a** are fixed to each other by welding for example.

Referring to FIG. **10**, a curved portion **86g**, which curves upward substantially in an arc shape, is formed at a substantially center portion in the fore-aft direction in an outer edge **86f** of the side wall portion **86b**. Likewise, a curved portion **86i** (see FIG. **8**), which curves upward substantially in an arc shape, is formed at a substantially center portion in the fore-aft direction in an outer edge **86h** (see FIG. **8** and see FIG. **11**) of the side wall portion **86c** (see FIG. **8** and see FIG. **11**).

The curved portion **86g** (see FIG. **10**) in the side wall portion **86b** (see FIG. **10**), the curved portion **82b** (see FIG. **8**) in the shaft member **82** (see FIG. **8**) and the curved portion **86i** (see FIG. **8**) in the side wall portion **86c** (see FIG. **8**) are fixed to an outer circumferential surface of the connection member **88** by welding, for example. As shown in FIG. **11**, the connection member **88** has an end **88a**, which protrudes more outward than the side wall portion **86b** of the restriction member **86**; and another end **88b**, which protrudes more outward than the side wall portion **86c**. Also, the shaft member **82** is fixed at an axially center portion in the connection member **88**.

Referring to FIG. **10**, the shaft member **82** has a center axis **82d**, which is located at a more forward position than a center axis **88c** of the connection member **88** when viewed from the side. Referring to FIG. **11**, the center axis **82d** and the center axis **88c** are perpendicular or substantially perpendicular to each other when viewed from the front.

Referring to FIG. **10** and FIG. **11**, the reinforcing member **90** is provided inside the restriction member **86** in order to reinforce the restriction member **86**. Referring to FIG. **8** and FIG. **10**, the reinforcing member **90** has a lower portion which is bent rearward to extend obliquely downward. Referring to FIG. **10** and FIG. **11**, the reinforcing member **90** has an upper end portion **90a**, which is fixed to the ceiling portion **86a** by welding for example. Referring to FIG. **11**, the reinforcing member **90** has a side end portion **90b**, which is fixed to the side wall portion **86b** by welding, for example; and a side end portion **90c**, which is fixed to the side wall portion **86c** by welding for example. The reinforcing member **90** has a lower end portion **90d**, which is fixed to an outer circumferential surface of the connection member **88** as well as to an outer circumferential surface of the shaft member **82** by welding for example.

FIG. **12** is a sectional view (taken along Arrow X4 direction in FIG. **8**), which shows how the ski **14**, the column assembly **18**, and the steering knuckle **60** are connected. Referring to FIG. **8** and FIG. **12**, in the main body portion **62** of the steering knuckle **60**, a generally cylindrical bushing **92** is fitted into the communication hole **62b** from the lower end **62a**. Referring to FIG. **8**, in the main body portion **62**, a generally cylindrical

bushing 93 is fitted into the communication hole 62b from the recess 65. The shaft member 82 of the column assembly 18 is inserted into the main body portion 62 so that an outer circumferential surface of the adjustment member 84 is supported by the bushing 92 and an outer circumferential surface of the shaft member 82 is supported by the bushing 93. The shaft member 82 is rotatable with respect to the bushing 93, and the adjustment member 84 is rotatable with respect to the bushing 92. Thus, the shaft member 82 is rotatable about the first pivot axis A1 which is an axis extending substantially in the vertical direction. A center axis 62f (see FIG. 9) of the main body portion 62 and the center axis 82d (see FIG. 10) of the shaft member 82 are substantially identical with the first pivot axis A1. It should be noted here that as shown in FIG. 13, the first pivot axis A1 is at a more forward position than the second pivot axis A2 within a virtual horizontal plane P1 which includes the second pivot axis A2. Preferably, a distance D5 from an intersection C1 made by the horizontal plane P1 and the first pivot axis A1 to the second pivot axis A2 is not smaller than about 15 mm, for example.

Referring to FIG. 8, inside the recess 65 of the main body portion 62, the pivot member 26f of the link mechanism 26 (see FIG. 2) is fixed to an upper portion 82c of the shaft member 82. Thus, the pivot member 26f is pivotable about the first pivot axis A1.

Referring to FIG. 12, a generally cylindrical flange member 94 is provided inside the through-hole 38a of the side wall portion 38 whereas a generally cylindrical flange member 96 is provided inside the through-hole 40a of the side wall portion 40. Cylindrical bushings 98, 100 are provided rotatably inside the connection member 88 of the column assembly 18. Inside the bushings 98, 100, a cylindrical collar 102 is inserted rotatably. A bolt 104 has its shank 104a inserted through the flange member 94, the collar 102 and the flange member 96. A nut 106 is threaded to a tip of the shank 104a. Thus, the connection member 88 of the column assembly 18 and the ski 14 are connected with each other. Via the bolt 104, the ski 14 is supported by the connection member 88 pivotably in the vertical direction about the second pivot axis A2. The center axis 88c (see FIG. 10) of the connection member 88 is substantially identical with the second pivot axis A2. It should be noted here that FIG. 8 does not show the bushings 98, 100 or the collar 102 so that the figure will not be too complicated.

FIG. 14 is an explanatory drawing of the ski 14, the column assembly 18, and the steering knuckle 60 viewed in Arrow X6 direction in FIG. 8. Referring to FIG. 8, FIG. 12, and FIG. 14, a stopper member 108, which is generally U-shaped in a side view, is provided between the ski 14 and the column assembly 18. The stopper member 108 is an elastic member made of rubber etc., for example. Referring to FIG. 15, the stopper member 108 has an upper surface, which is recessed at a center portion thereof as a substantially arc shaped recess 108a extending in the widthwise direction (Arrow X3 direction). Referring to FIG. 8 and FIG. 14, the stopper member 108 is provided between the side wall portion 86b (see FIG. 14) and the side wall portion 86c of the restriction member 86. Referring to FIG. 14, the stopper member 108 is restricted in its movement in Arrow X3 direction (the widthwise direction) by the side wall portions 86b, 86c of the restriction member 86. Referring to FIG. 8 and FIG. 12, the connection member 88 of the column assembly 18 is fitted into the recess 108a. Thus, the stopper member 108 is restricted in its upward movement. Referring to FIG. 8, the vertical pivoting movement of the ski 14 about the second pivot axis A2 is restricted

when the stopper member 108 makes contact with the ceiling portion 86a of the restriction member 86 or the reinforcing member 90.

In the present preferred embodiment, the link mechanism 26 and the column assembly 18 preferably function as the connecting section.

According to the configuration described above, when a human rider operates the steering mechanism 22 (see FIG. 2), the operation is transmitted via the steering shaft 24 (see FIG. 1) and the link mechanism 26 (see FIG. 2) to the shaft member 82 of the column assembly 18 (see FIG. 8). Thus, the shaft member 82 (FIG. 8) rotates about the first pivot axis A1, and the ski 14 (FIG. 8) pivots about the first pivot axis A1 in a horizontal direction. As a result, the snowmobile 10 is steered. It should be noted here with reference to FIG. 8 that the lower surface 36 of the ski 14 pivots about a point 36a (hereinafter called the pivot center 36a) on the first pivot axis A1.

Now, reference will be made to FIG. 4B. When the straight portion 42 is horizontal, the horizontal distance D2 between the rear end 42d of the straight portion 42 (the second straight portion 42b) and the second pivot axis A2 is longer than the horizontal distance D1 between the fore end 42c of the straight portion 42 (the first straight portion 42a) and the second pivot axis A2. In this case, it is possible in the straight portion 42 to ensure an area of contact between a rearward segment which is behind the second pivot axis A2 (the second straight portion 42b) and the snow surface (not illustrated). This makes it possible to improve a straight travel characteristic of the snowmobile 10. It should be noted here that even if the straight portion 42 has an extended rear segment behind the second pivot axis A2, the power steering device 28 assists the rotating operation of the steering shaft 24, thereby preventing the steering load from increasing.

Also, referring to FIG. 13, within the horizontal plane P1, the first pivot axis A1 is located at a more forward position than the second pivot axis A2. With reference to FIG. 8, therefore, when the ski 14 pivots in a horizontal direction, the pivot center 36a of the lower surface 36 in the ski 14 is at a more forward position than the second pivot axis A2. In this case, when the steering mechanism 22 is operated by a large steering angle (when the body 12 makes a sharp turn), a portion of the lower surface 36 in the ski 14 under the second pivot axis A2 moves to outside of the first pivot axis A1 with respect to the turning direction. Meanwhile, even if the ski 14 pivots in the vertical direction, the portion of the lower surface 36 in the ski 14 under the second pivot axis A2 pivots very little in the vertical direction. Therefore, even when the body 12 makes a sharp turn, it is possible to surely support the load from the body 12 by the portion of the lower surface 36 in the ski 14 under the second pivot axis A2. This reduces rolling of the body 12 during cornering operations, i.e., this improves a cornering characteristic of the snowmobile 10. It should be noted here that generally, in order to improve the cornering characteristic of a snowmobile, it is necessary to increase the length of a portion ahead of the second pivot axis in the ski. In this case, however, it becomes difficult to improve the straight travel characteristic. For this reason, conventionally, it has not been easy to improve both the straight travel characteristic and the cornering characteristic. On the contrary, according to the snowmobile 10, it is possible to improve the cornering characteristic as described earlier by an arrangement that the first pivot axis A1 is located at a more forward position than the second pivot axis A2 within the horizontal plane P1 which includes the second pivot axis A2. This eliminates the need for increasing the length of the portion ahead of the second pivot axis A2 in the ski 14 in order to improve the cornering

11

characteristic, making it possible to improve both the straight travel characteristic and the cornering characteristic.

Also, referring to FIG. 4A and FIG. 4B, when the straight portion 42 is horizontal, the fore end 48d of the keel portion 48 is at a lower position than the second pivot axis A2. In other words, the keel portion 48 is not formed in the approach portion 44 on its fore side (above side) of the ski 14. In this case, even if a rut, etc., is already formed on the snow surface, the keel portion 48 is not easily set in the rut, etc., when the approach portion 44 makes contact with the snow surface. This provides easy steering of the snowmobile 10, and provides a comfortable ride on the snowmobile 10.

Also, in the side surface 48a of the keel portion, the region 48f under the second straight portion 42b (region behind the second pivot axis A2 and ahead of the rear end 42d of the straight portion 42) has a larger area than the region 48e under the first straight portion 42a (region ahead of the second pivot axis A2 and behind the fore end 42c of the straight portion 42). Likewise, in the side surface 48b of the keel portion 48, the region under the second straight portion 42b (region behind the second pivot axis A2 and ahead of the rear end 42d of the straight portion 42) has a larger area than the region under the first straight portion 42a (region ahead of the second pivot axis A2 and behind the fore end 42c of the straight portion 42). In this case, it is possible to ensure snow contact areas in regions behind the second pivot axis A2 and ahead of the rear end 42d of the second straight portion 42b (straight portion 42) in the side surfaces 48a, 48b of the keel portion 48. This makes it possible to further improve the straight travel characteristic of the snowmobile 10.

Also, the chip member 55 is fixed to the runner 50 so that the center 55a in the fore-aft direction (longitudinal direction) of the chip member 55 is located at a more forward position than the second pivot axis A2. In this case, it is possible to make the center 55a of the chip member 55 close to the pivot center 36a (see FIG. 8) in the lower surface 36 of the ski 14. This makes it possible to further improve the cornering characteristic of the snowmobile 10.

Also, referring to FIG. 5, when the straight portion 42 is horizontal, the vertical distance D4 (about 33 mm, for example) between the straight portion 42 and the lower end 55b of the chip member 55 is sufficiently long. In this case, working of the chip member 55 (the runner 50) is improved, resulting in further improvement in the cornering characteristic.

In the above preferred embodiments, description was made for a case where the engine 30 preferably is a four-cylinder four-stroke engine which has a displacement of about 1,000 cc. However, the engine 30 is not limited to the example described above. For example, a two-cylinder or a three-cylinder engine or one which has five or more cylinders may be used. The engine may be a two-stroke engine. Also, the engine may have a greater displacement than 1,000 cc, or a smaller displacement than 1,000 cc. For example, a three-cylinder 800 cc engine may be used.

Also, in the above preferred embodiment, description was made for a case where the arm mechanism 16 preferably includes a steering knuckle 60. However, the arm mechanism may not have a steering knuckle 60. In this case, a column assembly may be attached to an upper arm mechanism and a lower arm mechanism of the arm mechanism, rotatably about the first axis line.

Also, in the above preferred embodiment, the straight portion 42 is a portion extending straightly in the lower surface 36 of the ski 14. However, the straight portion is not limited to portions which extend along a true straight line. For example, the straight portion may be a portion which extends along an

12

arc of an extremely large radius (not smaller than about 8,000 mm, for example). Also, a vertically upward recess may be formed locally or within a small range in the straight portion.

The present invention being thus far described in terms of preferred embodiments, it is obvious that these may be varied in many ways within the scope and the spirit of the present invention. The scope of the present invention is only limited by the accompanied claims.

The invention claimed is:

1. A snowmobile comprising:

a body;  
a steering mechanism;  
a steering shaft connected to the steering mechanism and arranged to operate in association with the steering mechanism;  
a power steering device connected to the steering shaft;  
a pair of skis;  
a runner provided in a lower surface of each of the skis; and  
a connecting section arranged to connect the pair of skis with the body and to support the skis for pivotal movement in a horizontal direction about a first pivot axis in association with movement of the steering shaft, and for pivotal movement in a vertical direction about a second pivot axis which extends in a widthwise direction of the body; wherein

the first pivot axis is located at a more forward position than the second pivot axis in a horizontal plane which includes the second pivot axis;

each of the skis includes, in the lower surface of the ski, a straight portion extending straight, an approach portion arranged forward of the straight portion and curving upward, and a keel portion protruding downward to a lower position than the straight portion and the approach portion;

a horizontal distance between the second pivot axis and a rear end of the straight portion is longer than a horizontal distance between the second pivot axis and a fore end of the straight portion, and a fore end of the keel portion is at a lower position than the second pivot axis, when the straight portion is horizontal;

the runner is provided in the keel portion of each of the skis; and

the keel portion includes a side surface including a first region between the second pivot axis and the rear end of the straight portion having a larger area than a second region between the second pivot axis and the fore end of the straight portion, when the straight portion is horizontal.

2. The snowmobile according to claim 1, further comprising a four-stroke engine defining a power source and being located in a front portion of the body.

3. A snowmobile comprising:

a body;  
a steering mechanism;  
a steering shaft connected to the steering mechanism and arranged to operate in association with the steering mechanism;  
a power steering device connected to the steering shaft;  
a pair of skis;  
a runner provided in a lower surface of each of the skis; and  
a connecting section arranged to connect the pair of skis with the body and to support the skis for pivotal movement in a horizontal direction about a first pivot axis in association with movement of the steering shaft, and for pivotal movement in a vertical direction about a second pivot axis which extends in a widthwise direction of the body; wherein

**13**

the first pivot axis is located at a more forward position than the second pivot axis in a horizontal plane which includes the second pivot axis;  
each of the skis includes, in the lower surface of the ski, a straight portion extending straight, an approach portion arranged forward of the straight portion and curving upward, and a keel portion protruding downward to a lower position than the straight portion and the approach portion;  
a horizontal distance between the second pivot axis and a rear end of the straight portion is longer than a horizontal distance between the second pivot axis and a fore end of the straight portion, and a fore end of the keel portion is

**14**

at a lower position than the second pivot axis, when the straight portion is horizontal;  
the runner is provided in the keel portion of each of the skis;  
the snowmobile further comprises a chip member provided in the runner and arranged to protrude downward to a lower position than the runner; and  
the chip member has a center in a fore-aft direction located at a more forward position than the second pivot axis.  
**4.** The snowmobile according to claim **3**, further comprising a four-stroke engine defining a power source and being located in a front portion of the body.

\* \* \* \* \*