



US00D569307S

(12) **United States Design Patent**
Albertsson

(10) **Patent No.:** **US D569,307 S**

(45) **Date of Patent:** **** May 20, 2008**

(54) **SLED BRAKE SHOE**

(76) Inventor: **Stig Albertsson**, 161 Dorset Rd., East
Dorset, VT (US) 05253

(**) Term: **14 Years**

(21) Appl. No.: **29/279,632**

(22) Filed: **May 4, 2007**

(51) **LOC (8) Cl.** **12-14**

(52) **U.S. Cl.** **D12/6; D12/11**

(58) **Field of Classification Search** **D12/6,**
D12/7, 154, 10, 574, 578, 577, 9, 11, 180;
105/418; 180/181, 9.1; 238/14; 280/28,
280/810, 18, 16, 20; 305/810; D6/582-586;
D21/203, 771, 776; D25/109, 110, 112,
D25/113, 118, 111

See application file for complete search history.

(56) **References Cited**

U.S. PATENT DOCUMENTS

488,266	A *	12/1892	Jordan	280/28
2,202,309	A *	5/1940	Campbell	280/28
D296,724	S *	7/1988	Peterson	D2/957
D298,683	S *	11/1988	Kelley et al.	D2/954
4,784,068	A *	11/1988	Burke	105/418
4,787,556	A *	11/1988	Heisson	238/14
4,827,631	A *	5/1989	Thornton	36/102
4,913,062	A *	4/1990	Burke	105/418
5,566,514	A *	10/1996	Freller	52/79.5
5,607,210	A *	3/1997	Brazier	305/131
D383,976	S *	9/1997	Allinsmith et al.	D9/430
D383,977	S *	9/1997	Allinsmith et al.	D9/433
5,810,376	A *	9/1998	Matheny	280/87.042
5,913,374	A *	6/1999	Becker et al.	180/9.1
6,257,620	B1 *	7/2001	Kenney	280/810

6,290,009	B1 *	9/2001	Kondo et al.	180/9.1
D475,183	S *	6/2003	McClaskie	D2/957
2002/0074176	A1 *	6/2002	Justus et al.	180/181
2004/0154849	A1 *	8/2004	Fodor	180/181
2004/0227312	A1 *	11/2004	Dick et al.	280/28
2005/0077693	A1 *	4/2005	Simmons et al.	280/28

* cited by examiner

Primary Examiner—Robert M. Spear

Assistant Examiner—Anna K Dworzecka

(74) *Attorney, Agent, or Firm*—Heslin Rothenberg Farley &
Mesiti P.C.; Victor A. Cardona

(57) **CLAIM**

The ornamental design for a sled brake shoe, as shown and described.

DESCRIPTION

FIG. 1 is a perspective view of a sled brake shoe comprising the new design;

FIG. 2 is a top plan view thereof;

FIG. 3 is a right side elevational view thereof, which is a mirror image of the left side elevational view thereof;

FIG. 4 is an end elevational view thereof, which is identical to the other end elevational view;

FIG. 5 is a bottom plan view thereof;

FIG. 6 is a perspective view of the new design mounted on a sled shown in phantom; and,

FIG. 7 is a perspective view of another embodiment comprising the new design.

In the drawings, the broken lines depict environmental subject matter only and form no part of the claimed design.

1 Claim, 4 Drawing Sheets

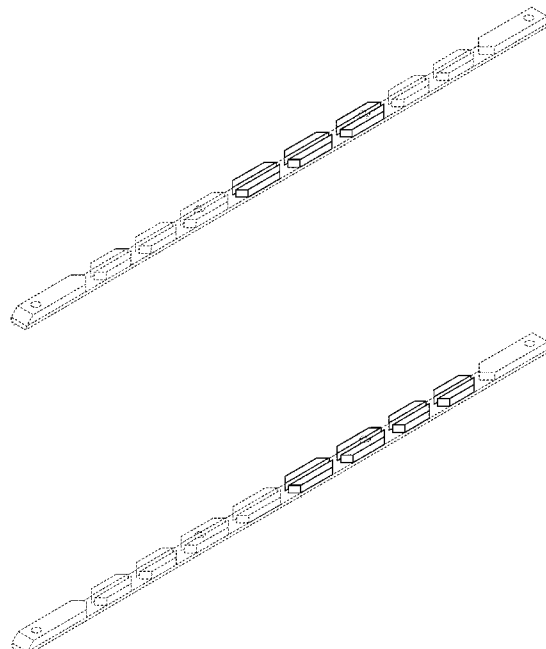

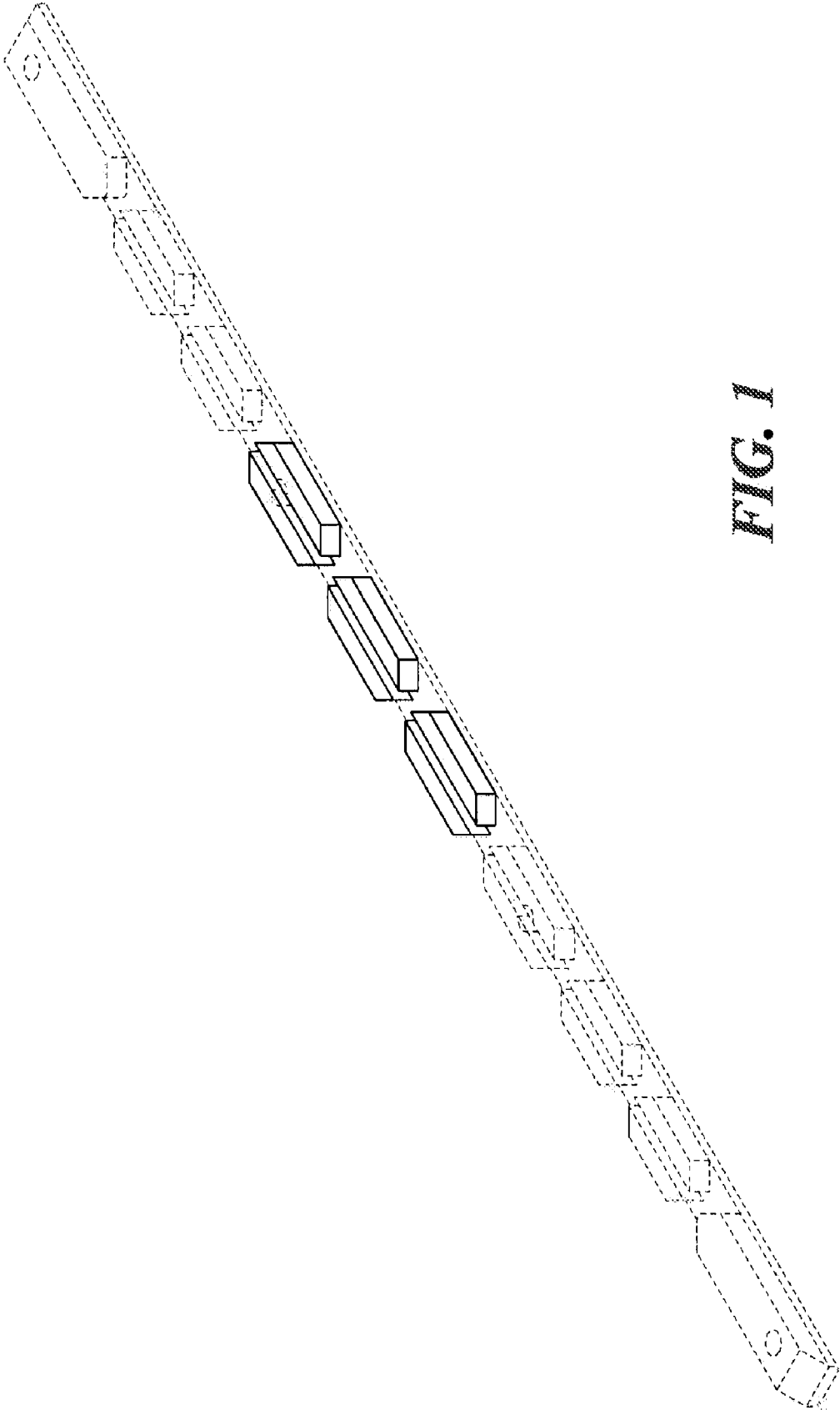

FIG. 1



FIG. 2

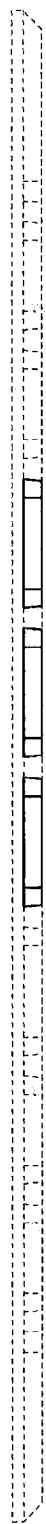

FIG. 3

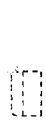

FIG. 4



FIG. 5

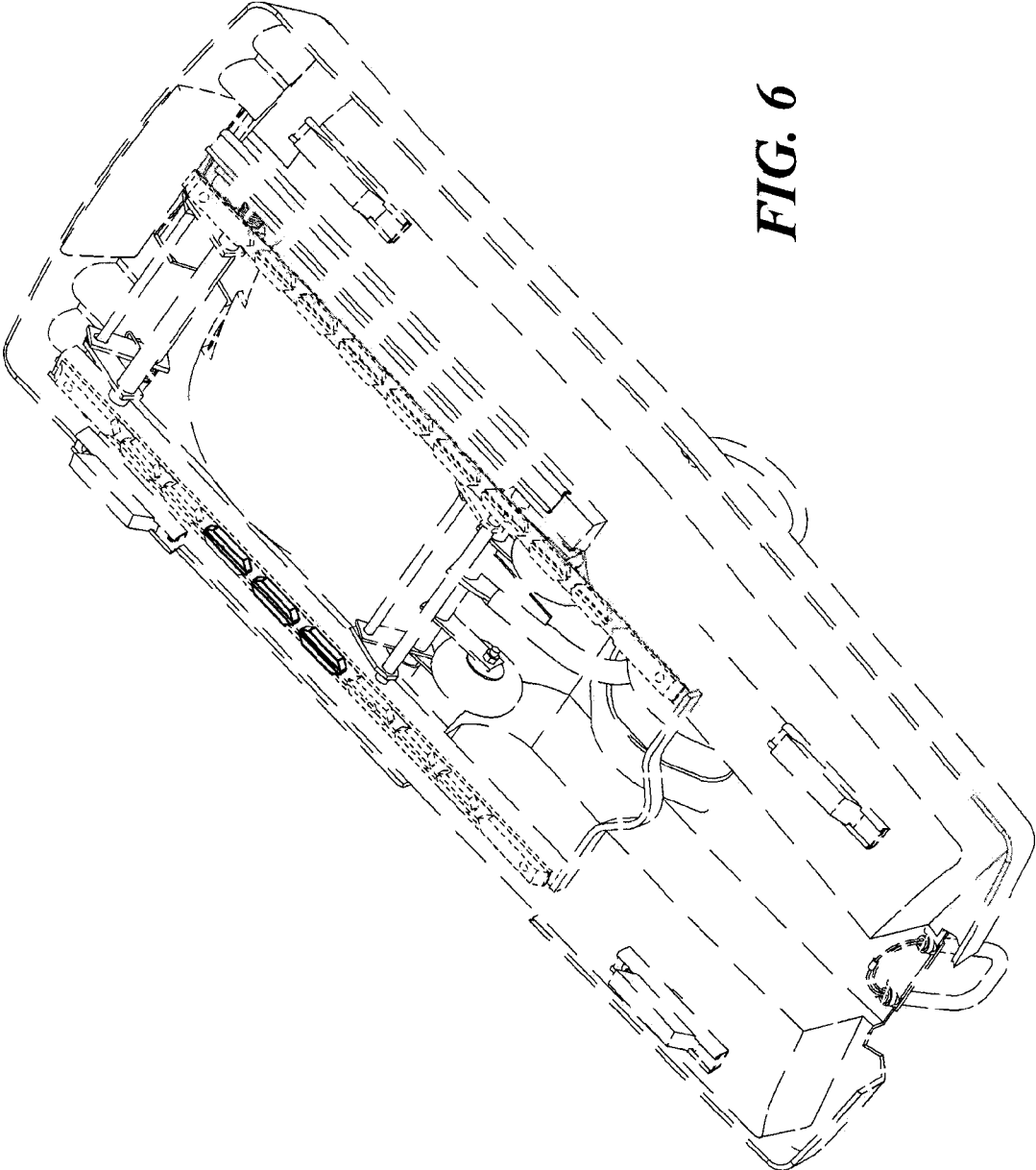

FIG. 6

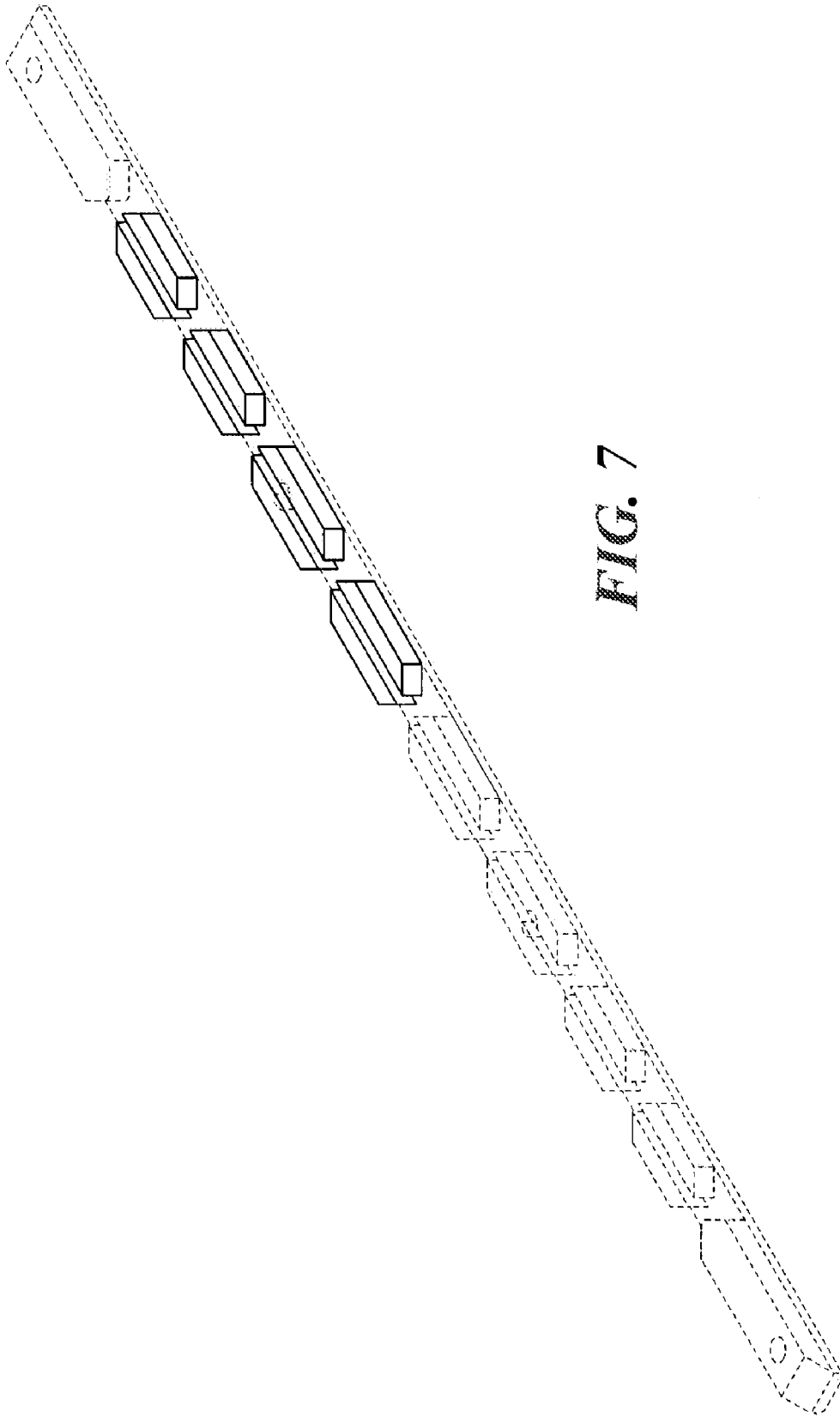

FIG. 7