

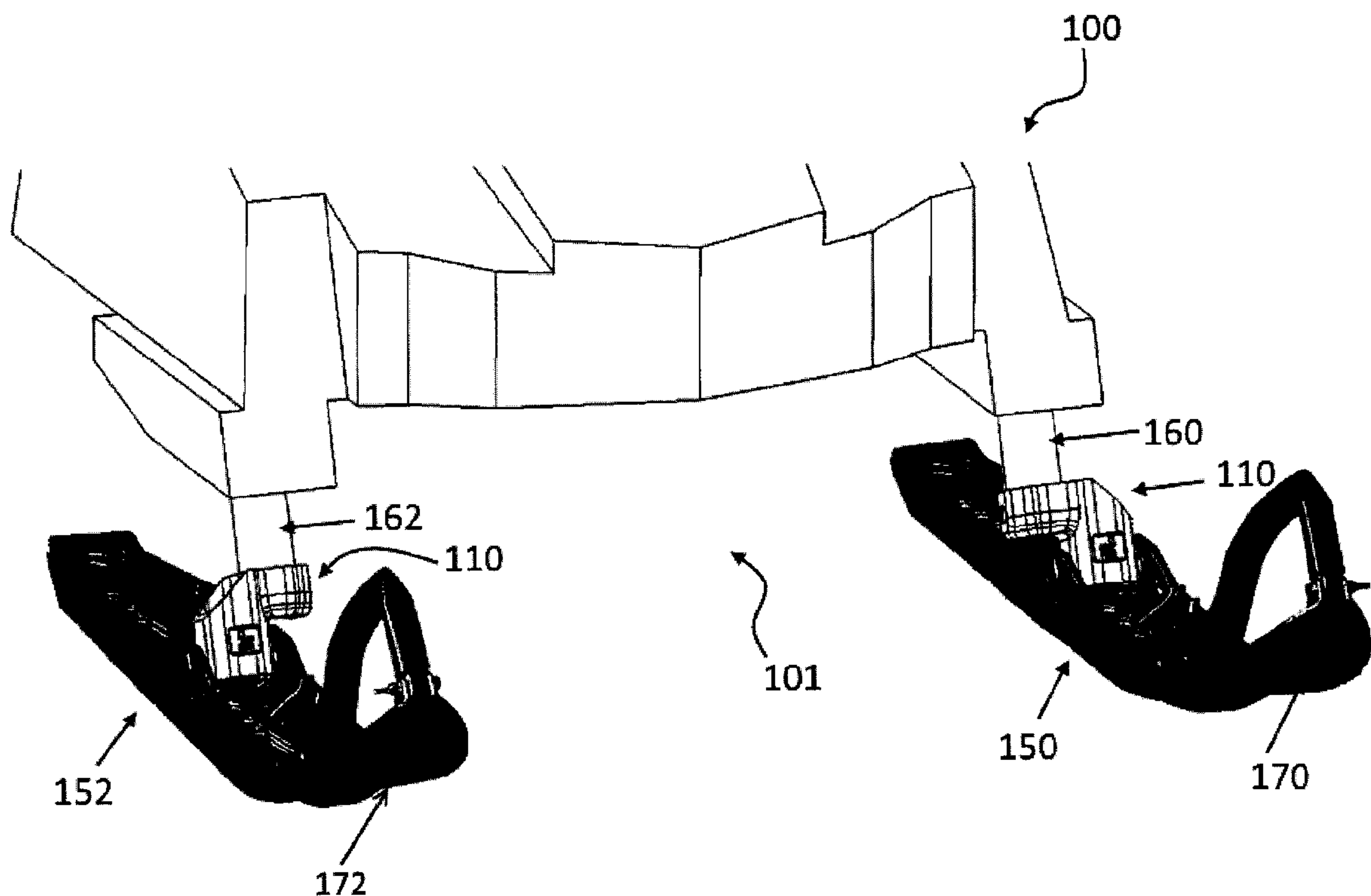

(22) **Date de dépôt/Filing Date:** 2017/03/03
(41) **Mise à la disp. pub./Open to Public Insp.:** 2017/09/03
(30) **Priorité/Priority:** 2016/03/03 (US62/303,195)

(51) **Cl.Int./Int.Cl. B62B 17/04** (2006.01),
B62D 55/07 (2006.01)
(71) **Demandeur/Applicant:**
INVESTISSEMENTS D. BEAUDOIN INC., CA
(72) **Inventeur/Inventor:**
BEAUDOIN, DENIS, CA
(74) **Agent:** BROUILLETTE LEGAL INC.

(54) **Titre : INSERTION DE STABILISATEUR DESTINEE A UNE MOTONEIGE**
(54) **Title: STABILIZER INSERT FOR A SNOWMOBILE**



(57) **Abrégé/Abstract:**

A stabilizer insert for a snowmobile is disclosed. The stabilizer insert comprises an upper portion adapted to receive a snowmobile spindle and a lower portion adapted to be secured to a snowmobile ski. The upper portion and the lower portion are being joined in a way that longitudinally and, optionally, laterally offsets the upper portion from the lower portion. Thus, the stabilizer insert longitudinally and, optionally, laterally offset the ski from its pre-set or manufactured position thus enlarging or narrowing the wheelbase/ski-track base, improving the pitch angle of the skis which improves the floatation of the front of the snowmobile over the snow in which it is operated, and preferably enlarging or narrowing the ski stance.

File: 11517-019

Abstract

A stabilizer insert for a snowmobile is disclosed. The stabilizer insert comprises an upper portion adapted to receive a snowmobile spindle and a lower portion adapted to be secured to a snowmobile ski. The upper portion and the lower portion are being joined in
5 a way that longitudinally and, optionally, laterally offsets the upper portion from the lower portion. Thus, the stabilizer insert longitudinally and, optionally, laterally offset the ski from its pre-set or manufactured position thus enlarging or narrowing the wheelbase/ski-track base, improving the pitch angle of the skis which improves the floatation of the front of the snowmobile over the snow in which it is operated, and
10 preferably enlarging or narrowing the ski stance.

File: 11517-019

Title of the Invention

Stabilizer Insert for a Snowmobile

Cross-Reference to Related Applications

[0001] The present patent application claims the benefits of priority of United States
5 Provisional Patent Application No. 62/303,195 entitled "Stabilizer Insert for a
Snowmobile", and filed at the United States Patent and Trademark Office on March 3,
2016.

Field of the Invention

[0002] The invention relates generally to snowmobiles. More particularly, the invention
10 relates to mounting arrangements for snowmobile skis.

Background of the Invention

[0003] Snowmobiles are popular recreational and utilitarian vehicles for use in snowy
conditions. Snowmobiles are driven for variety of purposes and under a variety of
conditions. For example, snowmobiles are used for touring, racing, and rescue operations
15 in remote areas. The conditions in which snowmobiles are operated can significantly
impact the performance of the snowmobile. For instance, the snow conditions may be
light and powdery or conversely, it may be hard packed.

[0004] Typical snowmobiles include, inter alia, a pair of skis for steering, a seat,
handlebars, and an endless track for propulsion mounted to a central chassis. The pair of
20 skis serve to facilitate steering as well as to provide floatation of the front of the
snowmobile over the snow in which it is operated. The ski stance of a snowmobile refers
to the distance separating the left and right ski as measured from a predetermined location
on each ski. The ski stance significantly impacts the driving performance and handling of
the snowmobile.

25 [0005] Driving performance of the snowmobile is of momentous importance to
snowmobile enthusiasts. Characteristics such as, steerability, maneuverability, floatation,
and side-hilling capability contribute to the ride characteristics of a snowmobile.

File: 11517-019

Particular characteristics become important when the snowmobile is driven in certain terrain or snow conditions.

[0006] In the prior art, there are at least two known types of skis. The first is called a single-keel ski because it incorporates a single keel having a single or double runners, which runs along a longitudinal part of the length of the underside of the keel. The second conventional ski is called the dual-keel ski because it incorporates a pair of keels which have runners that extend along longitudinal portions of the undersurface of the snowmobile ski at positions laterally disposed apart from one another. For the second type of ski, the two runners typically are disposed one each on the two lateral edges of the keels.

[0007] Most snowmobiles that have been made in the last twenty years have included two skis at the front for turning the vehicle. The ski stance for snowmobiles is determined as the distance (or width) between the two skis. In particular, where a snowmobile is provided with a pair of single-runner skis, which is the more common example to date, the ski stance is measured as the distance (or width) between the runners at the bottoms of the skis. In the case of a snowmobile fitted with a pair of dual-runner skis, the stance is measured as the distance between the centerlines of the skis (or some other suitable convention).

[0008] Conventionally, snowmobiles are manufactured with a pre-set ski stance. Depending on the type of terrain in which the snowmobile is used, the pre-set ski stance may have either a positive or a negative effect on the performance of the snowmobile.

[0009] As a general rule, there are two basic types of riding conditions for snowmobiles. Each of these two riding conditions places different demands on the snowmobile. Accordingly, each requires a different ski stance.

[0010] The first type of riding condition is the groomed trail. Groomed trails include a base of compacted snow, generally with a layer of loose snow above the compacted snow. Because the groomed trail has a solid, compacted base layer, the runners on the bottoms of the snowmobile skis are generally always in contact with the compacted surface. The runners, therefore, provide the edge upon which a turn may be executed. For maximum stability of the snowmobile on a groomed trail, the ski stance is usually pre-set

File: 11517-019

to the widest distance possible. Generally, the maximum width is set so that snowmobiles do not interlock skis when passing one another on groomed trails.

[0011] The second type of riding condition, which is antithetical to the first, is mountain terrain. Mountain snowmobiling differs considerably from snowmobiling on groomed trails because the snow is generally loose, powder snow, which is often deeper than the height of the skis. In other words, in mountain conditions, the bottoms of the skis almost never touch the ground. Therefore, the runners do not assist in turning the vehicle as much as when on groomed trails.

[0012] In mountain snowmobiling, it is the preferred practice to keep the ski stance to the smallest width possible. A small ski stance facilitates side hilling of the snowmobile. Side hilling is a technique used by mountain snowmobilers to climb the side of a mountain. The technique requires riders to traverse the mountain diagonally, thus, requiring riders to lean the snowmobile into the surface of the mountain to keep the snowmobile in a substantially horizontal position while crisscrossing the selected mountain area. In order to facilitate leaning of the snowmobile, it is preferred to decrease the distance between the ski and the frame (also referred to as the "tunnel") of the snowmobile. This decreases the moment applied to the snowmobile by the ski. It also permits the snowmobile to get closer to the side of the mountain. In mountain snowmobiling, snowmobiles usually traverse wooded areas. Therefore, a narrow ski stance is particularly advantageous, because riders may pass more easily between trees and other obstacles not encountered on groomed trails.

[0013] Since the stances for mountain and trail riding conditions are so different from one another, manufacturers currently manufacture different snowmobiles specifically tailored to the specific environment in which they are to be used. Groomed trail snowmobiles are typically manufactured with the widest stance in order to maintain maximum stability. Mountain snowmobiles, on the other hand, are manufactured with as narrow a stance as possible to facilitate side hilling and also retain the necessary balance of the vehicle while riding.

[0014] Because the two types of snowmobiles have such different stances, the average consumer faces a dilemma when purchasing a snowmobile. Purchasers who desire a

File: 11517-019

snowmobile that will handle optimally both on groomed trails and on mountain terrain will not find such a vehicle commercially available. In addition, purchasers located in areas where there is significant snowfall and few trails, while they may require a mountain snowmobile to navigate local conditions, may not desire a snowmobile
5 designed specifically for climbing hills and mountains. For consumers that live in heavy snowfall areas and do not necessarily engage in mountain climbing but do engage off-trail riding, a higher degree of stability can be achieved by increasing the narrow stance of a conventional mountain sled.

[0015] One way to alter the ski stance of a conventional snowmobile is to increase or
10 decrease the distance between the frame and the spindle holder by altering the length of the lower arm assembly and the upper arm assembly, both of which attach the spindle holder to the frame. Although this alters the ski stance of the snowmobile, such a modification requires realignment of the steering rod and the stabilizer bar. This modification also necessitates readjustment of the shock assembly because of the many
15 parts that individually connect to the arm at a predetermined distance from the frame.

[0016] Furthermore, the distance between a predetermined longitudinal location of the each ski and a predetermined location of the endless track may be known as the ski-track base. The ski-track base significantly impacts the driving performance and handling of the snowmobile as the wheelbase impacts the driving performance of a four-wheel
20 vehicle.

[0017] Typically, snowmobiles are manufactured with a pre-set ski-track base. Depending on the type of terrain in which the snowmobile is used or on the type of driving habits of a snowmobile driver, the pre-set ski-track base may have either a positive or a negative effect on the performance of the snowmobile. As such distance
25 between the track and the skis may not be changed, a snowmobile owner or driver may not adapt such configuration in order to obtain a positive effect on the performance of the snowmobile.

[0018] Thus, a novel stabilizer insert aiming at mitigating the shortcomings of the prior art is needed.

File: 11517-019

Summary of the Invention

[0019] The shortcomings of the prior art are generally mitigated by providing a stabilizer insert configured to be mounted on the snowmobile ski at the location where the spindle is typically inserted, the spindle being mounted in the stabilizer.

5 [0020] It is, therefore, an aspect of the present invention to provide a stabilizer insert designed to be inserted or installed between the snowmobile spindle and the ski to aim at improving the riding behavior of the snowmobile in various terrain conditions. Such stabilizer is configured to generally alter the altering the wheelbase or ski-track base and optionally the ski stance. As such, the stabilizer insert aims at allowing snowmobile with
10 a pre-set narrow stance to have an enlarged stance and behave more like a snowmobile designed for groomed trails.

[0021] According to one aspect of the present invention, the stabilizer facilitates altering the stance of a snowmobile without having to significantly rework or replace the snowmobile's suspension. As such, the stabilizer insert may generally be installed within
15 a few minutes.

[0022] It is another aspect of the present invention to provide stabilizer insert for a snowmobile having an upper portion which defines an axis of rotation along the spindle and a lower portion which defines a pivot axis within the ski, wherein the axis of rotation is offset from the midpoint of the lower portion.

20 [0023] Yet another aspect of the present invention is to provide a stabilizer insert acting as a removable spacer. The stabilizer insert thus increases the length between the snowmobile and the ski.

[0024] It is yet another aspect of the present invention to provide a snowmobile with a stabilizer insert, which can be placed on the opposite side of the snowmobile to alter the
25 ski stance. In other words, one aspect of the present invention is to provide a snowmobile with interchangeable stabilizer inserts. Accordingly, inverting the stabilizer insert from the left and right skis will result in increasing or decreasing the stance from the same distance.

File: 11517-019

[0025] It is still yet another aspect of the present invention to provide a snowmobile with a stabilizer insert having an upper portion adapted to receive a wide variety of spindle.

[0026] It is another aspect of the present invention to provide a snowmobile with a ski including a runner having a longitudinal axis attached to the underside of the ski, wherein
5 the axis of rotation of the spindle is laterally or longitudinally offset from the attach point of the lower portion.

[0027] Other and further aspects and advantages of the present invention will be obvious upon an understanding of the illustrative embodiments about to be described or will be indicated in the appended claims, and various advantages not referred to herein will occur
10 to one skilled in the art upon employment of the invention in practice.

Brief Description of the Drawings

[0028] The above and other aspects, features and advantages of the invention will become more readily apparent from the following description, reference being made to the accompanying drawings in which:

15 [0029] Figure 1 illustrates a front perspective view of a snowmobile having an embodiment of the stabilizer insert installed on each ski in accordance with the principles of the present invention mounted thereto.

[0030] Figure 2 is a top side perspective view of the skis and the spindles of the snowmobile of Figure 1.

20 [0031] Figure 3 is a rear perspective view of the right ski and the right spindle of the snowmobile of Figure 1.

[0032] Figure 4 is a close perspective view of the right ski and the right spindle of the snowmobile of Figure 1.

25 [0033] Figure 5 is a bottom right perspective view of the skis and the spindles of the snowmobile of Figure 1.

[0034] Figure 6 is a perspective view of an assembly of the right ski and the right spindle of a snowmobile showing a stabilizer insert in accordance with the principles of the present invention mounted thereto.

File: 11517-019

[0035] Figure 7 is a perspective view of a stabilizer insert according to an embodiment of the present invention.

[0036] Figure 8 is a top view of the stabilizer insert of Figure 7.

[0037] Figure 9 is a cross sectional view along the B-B axis of the stabilizer insert of
5 Figure 8.

[0038] Figure 10 is a cross sectional view along the A-A axis of the stabilizer insert of Figure 8.

[0039] Figure 11 is a cross sectional view along the C-C axis of the stabilizer insert of Figure 8.

10 [0040] Figure 12 is an exploded view of the assembly of the Figure 6.

[0041] Figure 13 is a perspective view of the skis and the spindles of the snowmobile having another embodiment of the stabilizer insert in accordance with the principles of the present invention mounted thereto.

[0042] Figure 14 is a perspective view of the right ski and the right spindle of the
15 snowmobile of Figure 13.

[0043] Figure 15 is a close perspective view of the right ski and the right spindle of the snowmobile of Figure 13.

[0044] Figure 16 is a perspective view of the skis and the spindles of the snowmobile of Figure 13.

20 **Detailed Description of the Preferred Embodiment**

[0045] A novel stabilizer insert 110 for a snowmobile will be described hereinafter. Although the invention is described in terms of specific illustrative embodiments, it is to be understood that the embodiments described herein are by way of example only and that the scope of the invention is not intended to be limited thereby.

25 [0046] Throughout the description of the several embodiments of the present invention, reference will be made to various elements, the construction of which is readily known to those skilled in the art. Accordingly, an exhaustive description of each and every

File: 11517-019

component is not provided, only description of those elements required for an understanding of the present invention.

[0047] Generally, conventional snowmobiles comprise a main frame having a rear section being adapted to receive an endless track to propel the snowmobile and a front section being adapted to receive two skis configured to turn the snowmobile effectively as it is propelled forward by the endless track. The conventional snowmobiles further comprise a motor being operatively connected to the endless track disposed at the rear of the snowmobile beneath the frame. The motor is preferably an internal combustion engine being one of either the two-stroke or the four-stroke variety. Understandably, other type of engine may be now be used such as electric engine or hybrid engine. The conventional snowmobiles further comprise handlebars allowing a user to drive and to control the movement of the snowmobile. Such handlebars are typically disposed above and to the rear of the motor and are operatively connected, via a steering rod or another suitable connector, to the two skis disposed at the front section of the snowmobile. The handlebars allow controlling the direction of the snowmobile by controlling the movement of the two skis.

[0048] Referring to Figures 1-6, a front underside section 101 of a snowmobile 100 is illustrated. The front section 101 generally comprises a front suspension (not shown) which comprises, among other components, two arms 160 and 162, each disposed on a side of the snowmobile 100 and being connected to shock assemblies (not shown). The two arms 160 and 162, also referred to as spindles, are mounted, each, to a stabilizer insert 110, which is being mounted to two skis 150 and 152 being typically suspended from the non-illustrated front suspension. The skis 150 and 152 are, each, provided with one or more runners 170 and 172. The runners 170 and 172 extend along a portion of the undersides of the skis 150 and 152 and come into contact with the ground. The runners 170 and 172 are typically made of a wear-resistant material, such as but not limited to steel. Other constructions of the runners may be used without departing from the scope of the present invention.

[0049] Still referring to Figures 3-6, according to one embodiment, an assembly 102 of the right ski 152 and the right spindle 162 of a snowmobile 100 is illustrated. The

File: 11517-019

assembly 102 comprises a stabilizer insert 110 mounted thereto. The stabilizer insert 110 is mounted between the snowmobile ski 152 and the spindle 162. The stabilizer insert 110 preferably comprises an upper receiving portion 112 and a lower portion 114 both joined together in a way that at least longitudinally (along the z-axis) offsets the upper receiving
5 portion 112 from the lower portion 114. The receiving portion 112 and the lower portion 114 may further be joined together in a way that laterally (along the X-axis) offsets the upper receiving portion 112 from the lower portion 114. As such, the stabilizer insert 110 longitudinally and, optionally, laterally offsets the ski from its pre-set or manufactured position thus enlarging or narrowing the wheelbase/ski-track base and preferably the ski
10 stance. Understandably, the central vertical axis of the spindle 162 or 160 (extending along Y-axis) is always being coincident with the central vertical axis of the upper receiving portion 112 (extending along Y-axis).

[0050] Now referring to Figures 7-12, a first embodiment of a stabilizer insert 110 is illustrated. The stabilizer insert 110 comprises an upper receiving portion 112 being
15 longitudinally (along a Z-axis) and laterally (along X-axis) offset from the lower portion 114. In such a configuration, the central vertical axis of the upper receiving portion is being further longitudinally and laterally offset from the central vertical axis of the lower portion 114 while the central transversal axis (extending along X-axis) of the receiving portion 112 is being longitudinally offset from the central transversal axis (extending
20 along X-axis) of the lower portion 114.

[0051] Understandably, a longitudinal offset (along Z-axis) aims at changing the ski-track base and at creating an additional force or torque around the central transversal axis (extending along X-axis) of the upper receiving portion 112. Such a torque aims at positively or negatively affecting the floatation of the front of the snowmobile over the
25 snow on which it is operated. In a preferred embodiment, once the upper portion 112 is being offset behind the lower portion 114, the torque created around the central transversal axis of the upper receiving portion 112 increases the pitch angle of the ski 150 or 152, aiming then at improving the floatation of the front of the snowmobile over the snow.

File: 11517-019

[0052] Understandably, a lateral offset (along X-axis) aims at affecting the ski stance and at creating additional torque around a vertical axis, generally extending along Y-axis, of the upper receiving portion 112. Such a torque aims at affecting the stability and the directional manoeuvrability of the snowmobile. Such a torque aims at allowing a user to
5 more easily turn and guide the snowmobile skis.

[0053] . Referring back to Figures 7-12, the upper receiving portion 112 preferably comprises a section of the receiving cavity wall 124 at an angle, preferably 45 degrees, aiming at optimizing the mating of the receiving cavity 116 with the corresponding snowmobile ski arm 160 or 162. The walls of the receiving cavity 116 are generally
10 shaped to correspond to the snowmobile arms 160 or 162.

The lower portion 114 comprises a mounting portion 119 configured to be received in the ski mounting bracket 154 and secured to the ski mounting bracket using any attachment mean, typically a kingpin. The lower portion 114 may be hollow 118 to reduce the weight of the stabilizer insert 110. Alternatively, the stabilizer insert 110 lower
15 portion 114 may as well be made from a solid element deprived of any cavity 118 other than an opening 128 to receive the kingpin 158.

[0054] Further referring to Figures 7-11, the upper portion 112 preferably comprises an octagonal-like or rectangular-like outer structure, which comprises an internal cylindrical inner cavity 116 to reinforce the stabiliser insert 110 body. Likewise, the lower portion
20 114 also preferably comprises an octagonal-like or rectangular-like outer structure. Understandably, the lower portion 114 has an external width 130 substantially equal to the internal width 132 of the upper portion which receive the snowmobile ski arm 160 or 162 to allow the lower portion 114 to be received in the ski attachment bracket 154 and secured with an attachment mean, such as the kingpin 158. As such, according to one
25 embodiment, the lower portion 114 structure is generally shaped as a longitudinally elongated octagonal-like or rectangular-like structure (see Figure 10). Accordingly, such structure allows the stabilizer insert 110 to be of suitable strength while minimising the weight of the stabilizer insert 110.

File: 11517-019

[0055] According to one embodiment, still referring to Figure 10, depending on the width and/or length of the offset, where possible, the upper receiving portion 112 and lower portion 114 shall be vertically overlapping 134 to provide a greater structural strength.

[0056] According to another embodiment, as shown in Figures 9 and 12, the upper receiving portion 112 may be adapted to receive a supporting insert 163 being shaped to mate the angled section of the receiving cavity wall 124. The supporting insert 163 may be adapted to be inserted inside the cavity 116 of the upper portion 112 and configured to support the snowmobile spindle 162. Such a supporting insert 163 generally aims at improving the mechanicals properties of the assembly formed by the snowmobile spindle and the upper portion. The supporting insert 163 generally prevents the deterioration of the upper portion due to friction efforts.

[0057] Still referring to Figures 11 and 12, in such an embodiment, the upper receiving portion 112 is secured to the snowmobile arm 160, 162 by aligning the opening or aperture 136 to corresponding opening or aperture 165 of the snowmobile arm 160, 162 and inserting a kingpin 166 therein. Likewise, the lower portion 114 is received in the ski 150, 152 brackets 154, 156. In yet another embodiment, the lower portion 114 may be received by a ski supporting structure 159 adapted to be attached or received in one of the skis 150, 152.

[0058] The lower portion 114 may be further secured by inserting a bolt or a kingpin 158 in the brackets opening and in the opening 128 of the lower portion 114. The ski supporting structure 159 prevents the deterioration of the ski 152 due to friction efforts. The stabilizer insert 110 may be secured to the snowmobile arms 160, 162 and skis 150, 152 using any attachment mean, such as kingpins, screws, or any other suitable fasteners. Understandably, any other method of attaching the spindle 162 to the upper portion 112 and of attaching the lower portion 114 to the ski may be used without departing from the principles of the present invention.

[0059] According to a further embodiment of the present invention, the stabilizer insert is preferably made from a material adapted to withstand to the combined force of impacts and the weight of the front portion of the snowmobile. Suitable material for such use may be steel, aluminum, titanium or any combination thereof. Alternatively, the stabilizer

File: 11517-019

insert may be made from any composite material having a sufficient strength to withstand the force generated on the snowmobile ski arm 160, 162 while riding. As such, using composite material may improve the ease of manufacturing using innovative manufacture techniques such as 3D-printing for on demand manufacture of the stabilizer insert 110.

5 [0060] Understandably, the stabilizer insert 110 is preferably made in one piece structure in order to avoid any stress concentration at the junction between the upper and the lower portions due to a specific mechanical assembling process, such as but not limited to welding process.

10 [0061] Preferably, the stabilizer insert 110 is made in one-piece structure to avoid any need to reinforce especially the upper receiving portion 112 by adding supporting extruded structures.

[0062] Understandably, the lower portion 114 may extend from the upper portion 112 in any ways known in the art. As examples, the upper portion and the lower portion may either form a one-piece structure, may be welded one to the other or may be joined or
15 attached together with any fastening or attachment mean m.

[0063] Other embodiments of the stabilizer insert 110 may have alternate shapes to accommodate various kinds of spindle or ski arm 160, 162 and their respective attachment to the snowmobile ski 150, 152. As such, the stabilizer insert 110 should have a lower portion 114 configured to be received in the snowmobile ski 150, 152 mounting
20 brackets 154, 156. In order for the stabilizer insert 110 to suitably insert on an existing snowmobile 110, the upper receiving portion 112 must be identical or at least substantially similar to the mounting brackets 154, 156 of the snowmobile ski 160, 162. In which case, the upper receiving portion 112 is capable of receiving the lower portion of the snowmobile ski arm 160, 162 or spindle and the lower portion 114 is mounted in
25 the snowmobile ski bracket 154, 156. Such other embodiment will generally be required for snowmobile with ski arms 160, 162 or spindle having a shape other than a cylindrical member. Known snowmobile 100 often have spindles or ski arms of various shaped to allow mounting of different suspension systems. The stabilizer insert according to some embodiment may also be configured to receive spindles or ski arms which are not
30 cylindrically shaped.

File: 11517-019

[0064] According to some embodiments, referring now to FIGS. 1-14, the stabilizer insert 110 may, in addition to longitudinally offset the ski-track base, offset the ski 150, 152 laterally toward the interior or exterior from its original manufacture position, known as the pre-set position. The longitudinal and lateral offsets will generally be desired to
5 ride different terrain condition (i.e. mountain or groomed trails) or to adapt the snowmobile riding behavior when changing the skis 150, 152. Laterally offsetting the ski 150, 152 will alter the ski stance.

[0065] Referring now to FIGS. 13-16, another embodiment of the stabilizer insert 110A is shown. In such an embodiment, the stabilizer insert 110A is only longitudinally (along
10 Z-axis) offset the ski 150, 152 thus increasing the wheelbase of the snowmobile 100, which is the distance between the ski and the endless track. The increase in the wheelbase/ski-track aims at creating an additional torque or force around a generally central transversal axis (extending along the X-axis) of the upper receiving portion 112. The said torque generally results in an increase of the pitch angle of the ski 150 or 152
15 with regard to the ridden surface. The increase in the wheelbase/ski-track base may, for instance, be desired to improve the floatation of the front of the snowmobile over the snow in which it is operated and to improve the snowmobile riding behaviour or handling capability.

[0066] In other embodiments, the stabilizer insert 110 may laterally offset the ski 150 or
20 152 thus improving the ski stance. The increase in the ski stance may be desired to improve the stability and the directional manoeuvrability of the snowmobile.

[0067] In other embodiments, the stabilizer insert 110 also acts as a spacer to increase the length of the snowmobile ski arm 160, 162. As such, some embodiments may have an upper receiving portion 112 cavity 116 and a lower portion 114 that are spaced apart by a
25 spacer element to increase the distance between the snowmobile 100 and the ski 150, 152. The increase generally reduces the angle between the ski arms 160, 162 and the ground. The extent of the spacing is determined by measuring the distance between the lower and upper openings 128, 136 for the mounting bracket.

[0068] While illustrative and presently preferred embodiments of the invention have been
30 described in detail hereinabove, it is to be understood that the inventive concepts may be

File: 11517-019

otherwise variously embodied and employed and that the appended claims are intended to be construed to include such variations except insofar as limited by the prior art.

File: 11517-019

Claims

- 1) A stabilizer insert for a snowmobile, the snowmobile comprising at least one arm and at least one ski, the stabilizer insert comprising:
 - an upper portion adapted to receive the arm of the snowmobile;
 - 5 – a lower portion extending from the upper portion, the lower portion being adapted to be attached to the snowmobile ski and being longitudinally offset of the upper portion.
- 2) The stabilizer insert for a snowmobile of claim 1, wherein the upper portion is further laterally offset of the lower portion.
- 10 3) The stabilizer insert for a snowmobile of any of claim 1 or 2, wherein the upper portion vertically overlaps the lower portion.
- 4) The stabilizer insert for a snowmobile of any of claims 1 to 3, the lower portion having an external width and the upper portion having an internal width, the external width of the lower portion about the same as the internal width of the upper portion.
- 15 5) The stabilizer insert for a snowmobile of any of claims 1 to 4, wherein the upper portion comprises a cavity adapted to receive the arm of the snowmobile.
- 6) The stabilizer insert for a snowmobile of claim 5, the cavity of the upper portion comprising a wall being angled to mate with the arm of the snowmobile.
- 7) The stabilizer insert for a snowmobile of either of claim 5 or 6, the cavity of the upper
20 portion being shaped to match the shape of a cross-section of the arm of the snowmobile.
- 8) The stabilizer insert for a snowmobile of any of claims 5 to 7, the cavity being adapted to reinforce the stabilizer insert.
- 9) The stabilizer insert for a snowmobile of any of claims 1 to 8, the lower portion being
25 hollow.
- 10) The stabilizer insert for a snowmobile of any of claims 1 to 9, the lower portion comprising a mounting portion configured to be attached to a ski mounting bracket using an attachment mean.
- 11) The stabilizer insert for a snowmobile of any of claims 1 to 10, the upper portion
30 being attached to the arm of the snowmobile with a kingpin.

File: 11517-019

- 12) The stabilizer insert for a snowmobile of any of claims 1 to 11, the lower portion being attached to the arm of the snowmobile with a kingpin.
- 13) The stabilizer insert for a snowmobile of any of claims 1 to 12, the stabilizer insert being made of a material adapted to withstand to the combined force of impacts on the snowmobile ski and the weight of a front portion of the snowmobile.
- 14) The stabilizer insert for a snowmobile of any of claims 1 to 13, the stabilizer insert being made as a one-piece structure.
- 15) The stabilizer insert for a snowmobile of any of claims 1 to 14, wherein the upper portion and the lower portion have an octagonal-like structure.
- 16) The stabilizer insert for a snowmobile of any of claims 1 to 14, wherein the upper portion and the lower portion have a rectangular-like structure.
- 17) A stabilizer insert for a snowmobile, the snowmobile comprising at least one arm and at least one ski, the stabilizer insert comprising:
- an upper portion adapted to receive the arm of the snowmobile;
 - a lower portion extending from the upper portion, the lower portion being adapted to be attached to the snowmobile ski and being laterally offset of the upper portion;
- wherein the upper portion vertically overlaps the lower portion.
- 18) The stabilizer insert for a snowmobile of claim 17, wherein the upper portion is further longitudinally offset of the lower portion.
- 19) The stabilizer insert for a snowmobile of any of claims 17 or 18, the lower portion having an external width and the upper portion having an internal width, the external width of the lower portion about the same as the internal width of the upper portion.
- 20) The stabilizer insert for a snowmobile of any of claims 17 to 19, wherein the upper portion comprises a cavity adapted to receive the arm of the snowmobile.
- 21) The stabilizer insert for a snowmobile of claim 20, the cavity of the upper portion comprising a wall being angled to mate with the arm of the snowmobile.

File: 11517-019

- 22) The stabilizer insert for a snowmobile of either of claim 20 or 21, the cavity of the upper portion being shaped to match the shape of a cross-section of the arm of the snowmobile.
- 23) The stabilizer insert for a snowmobile of any of claims 20 to 22, the cavity being adapted to reinforce the stabilizer insert.
- 24) The stabilizer insert for a snowmobile of any of claims 17 to 23, the lower portion being hollow.
- 25) The stabilizer insert for a snowmobile of any of claims 17 to 24, the lower portion comprising a mounting portion configured to be attached to a ski mounting bracket using an attachment mean.
- 26) The stabilizer insert for a snowmobile of any of claims 17 to 25, the upper portion being attached to the arm of the snowmobile with a kingpin.
- 27) The stabilizer insert for a snowmobile of any of claims 17 to 26, the lower portion being attached to the arm of the snowmobile with a kingpin.
- 28) The stabilizer insert for a snowmobile of any of claims 17 to 27, the stabilizer insert being made of a material adapted to withstand to the combined force of impacts on the snowmobile ski and the weight of a front portion of the snowmobile.
- 29) The stabilizer insert for a snowmobile of any of claims 17 to 28, the stabilizer insert being made as a one-piece structure.
- 30) The stabilizer insert for a snowmobile of any of claims 17 to 29, wherein the upper portion and the lower portion have an octagonal-like structure.
- 31) The stabilizer insert for a snowmobile of any of claims 17 to 30, wherein the upper portion and the lower portion have a rectangular-like structure.
- 32) The stabilizer insert for a snowmobile of any of claims 1 to 16 and 18, the upper portion being longitudinally offset of the lower portion to increase ski-track base of the snowmobile.
- 33) The stabilizer insert for a snowmobile of any of claim 2 or 17 to 32, the upper portion being laterally offset of the lower portion to increase ski stance of the snowmobile.

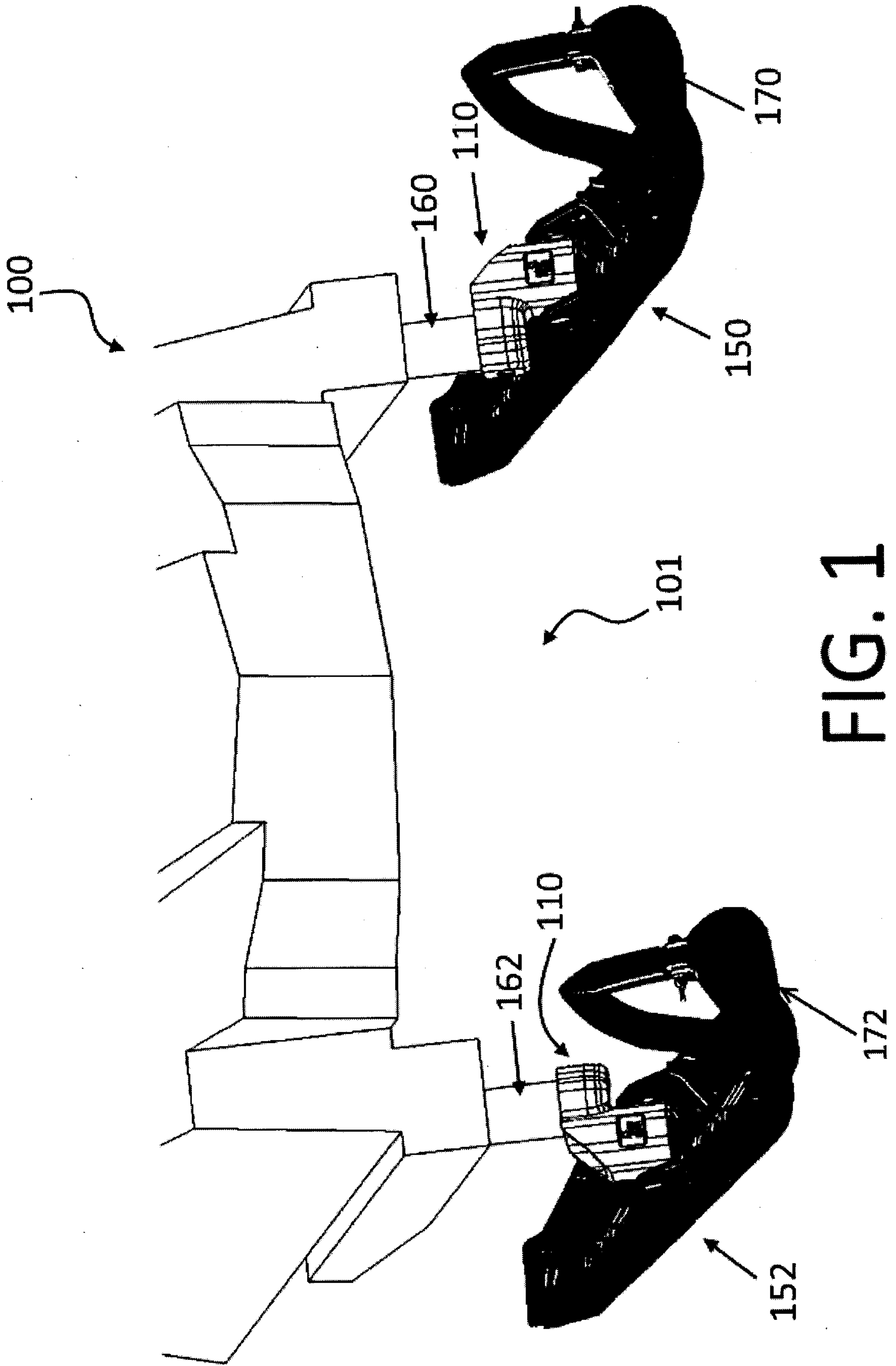

FIG. 1

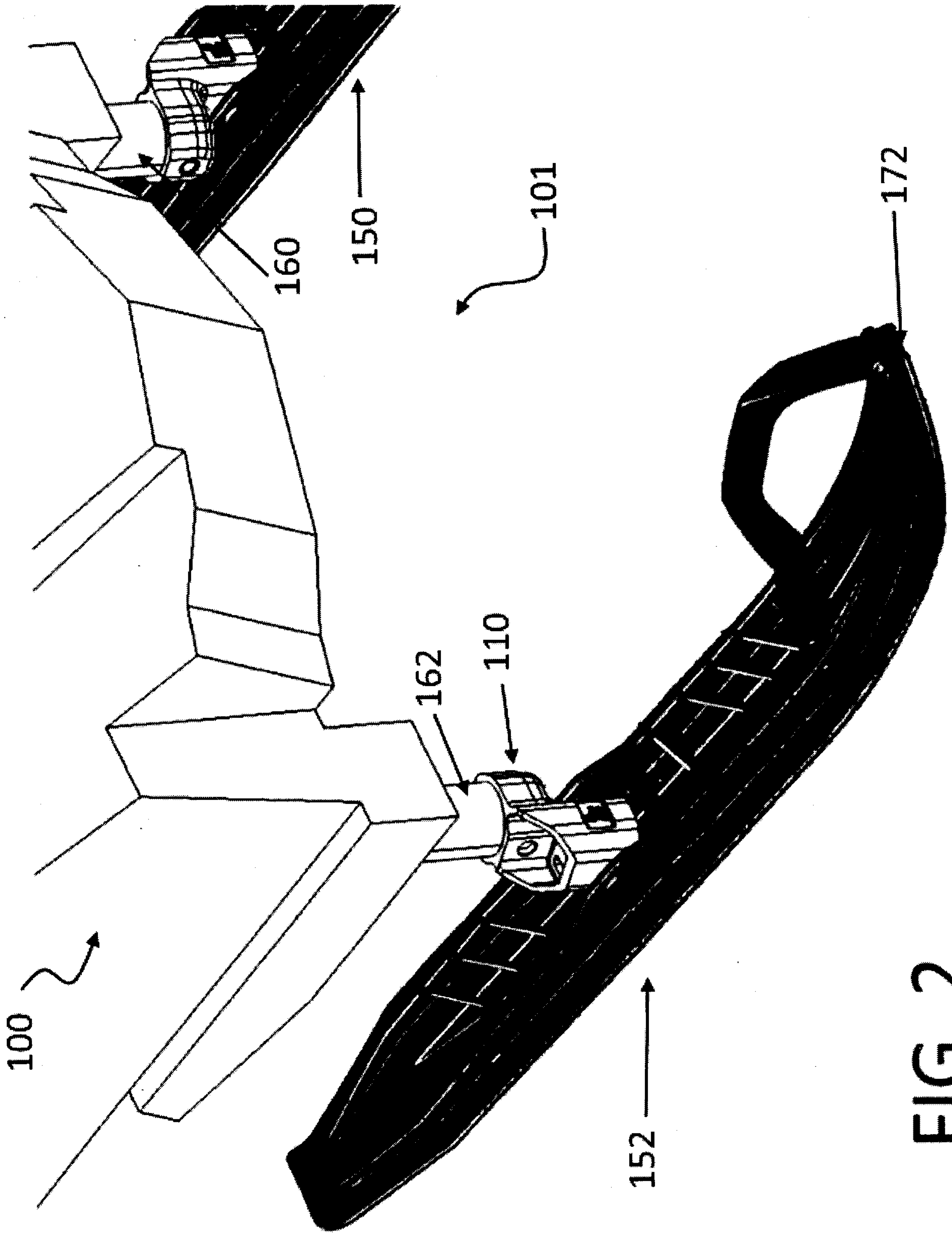

FIG. 2

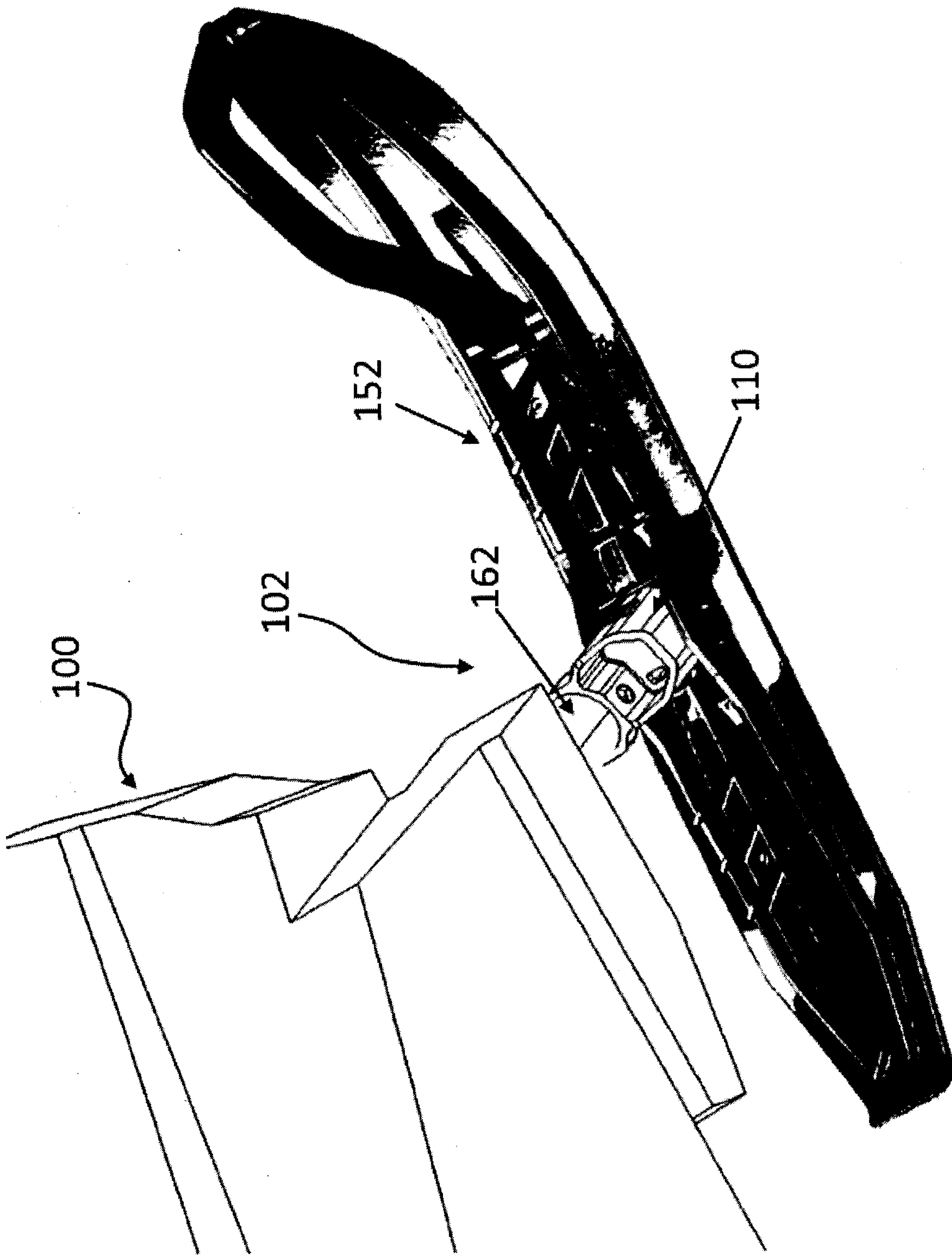
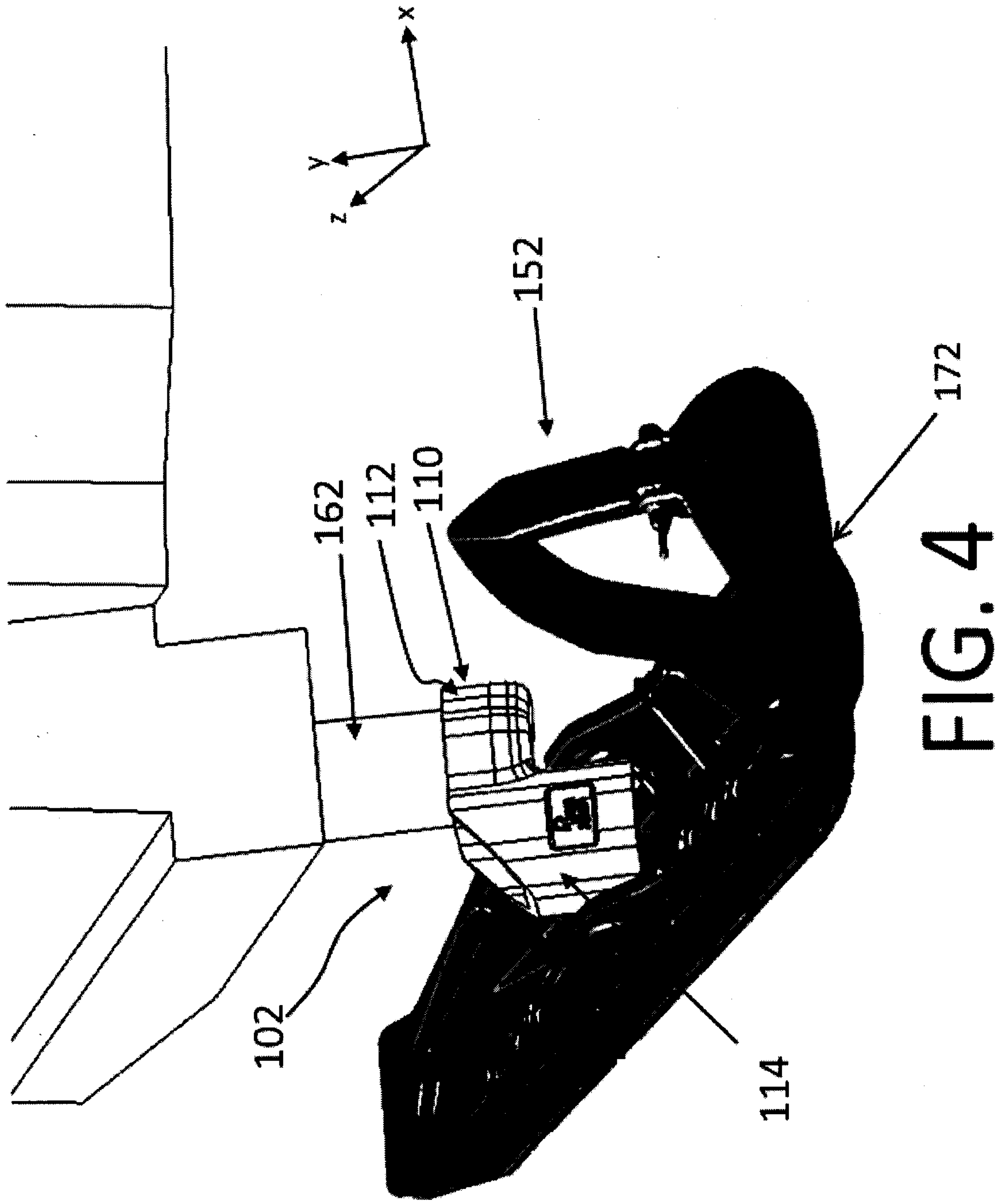

FIG. 3



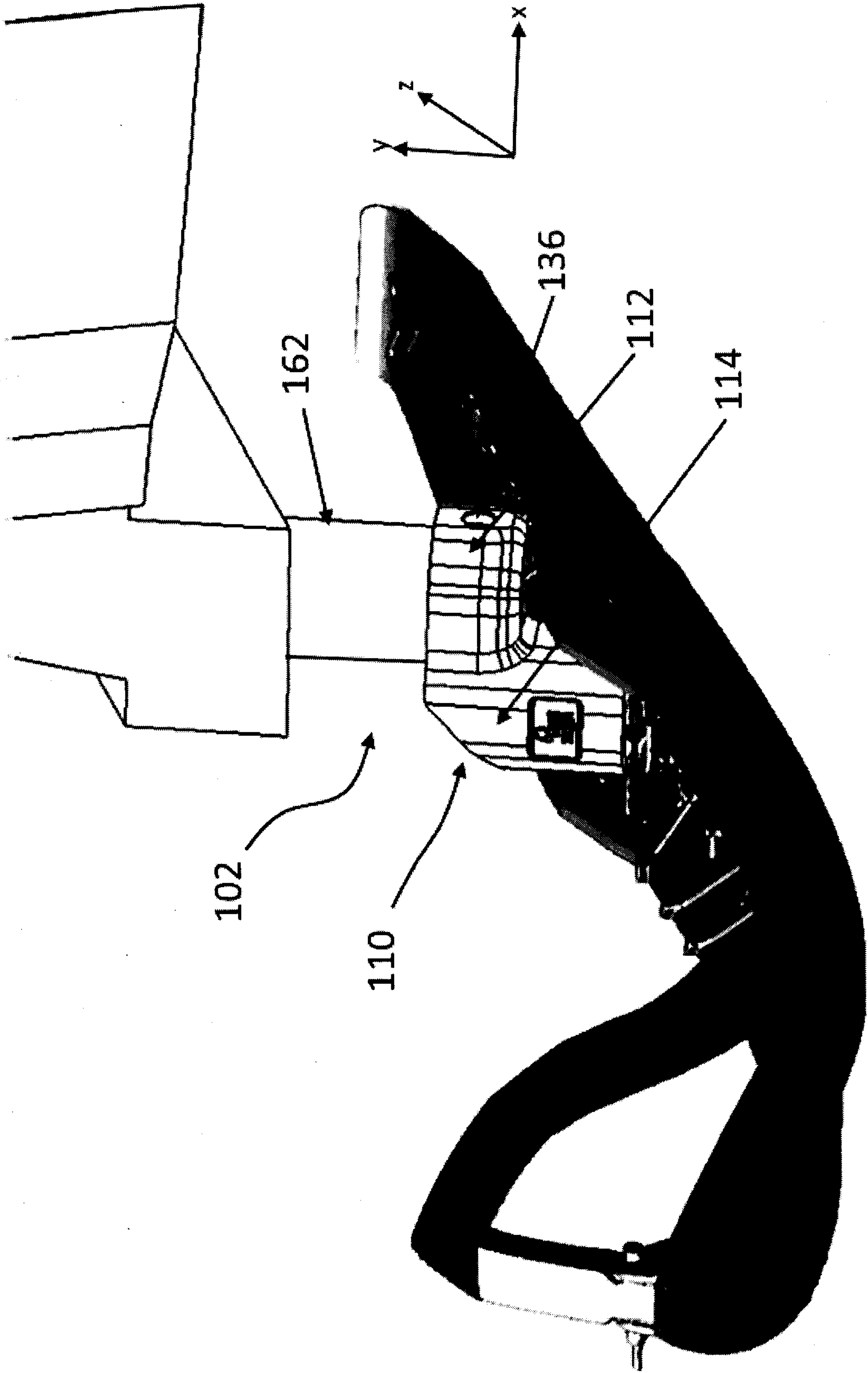

FIG. 5

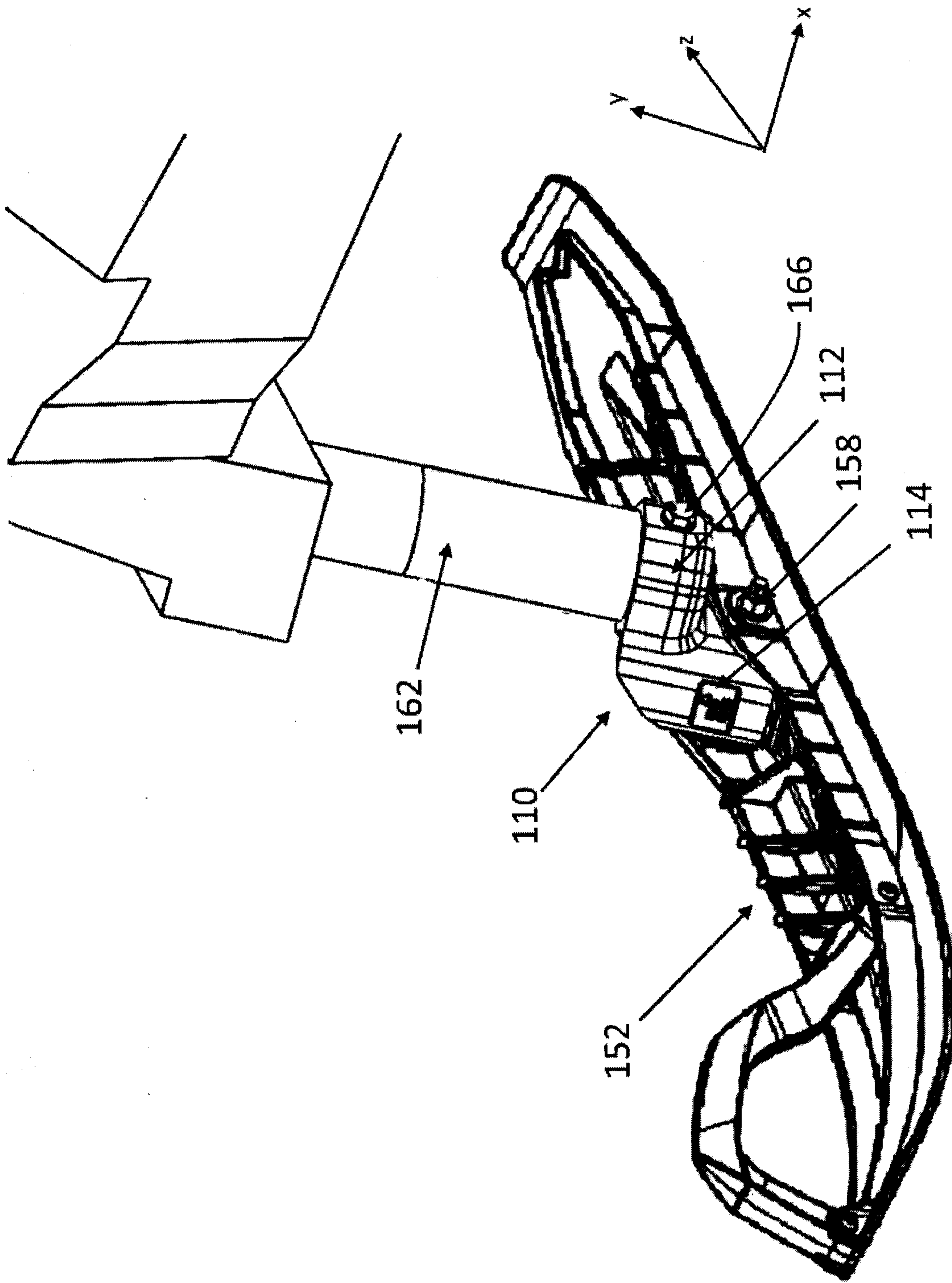

FIG. 6

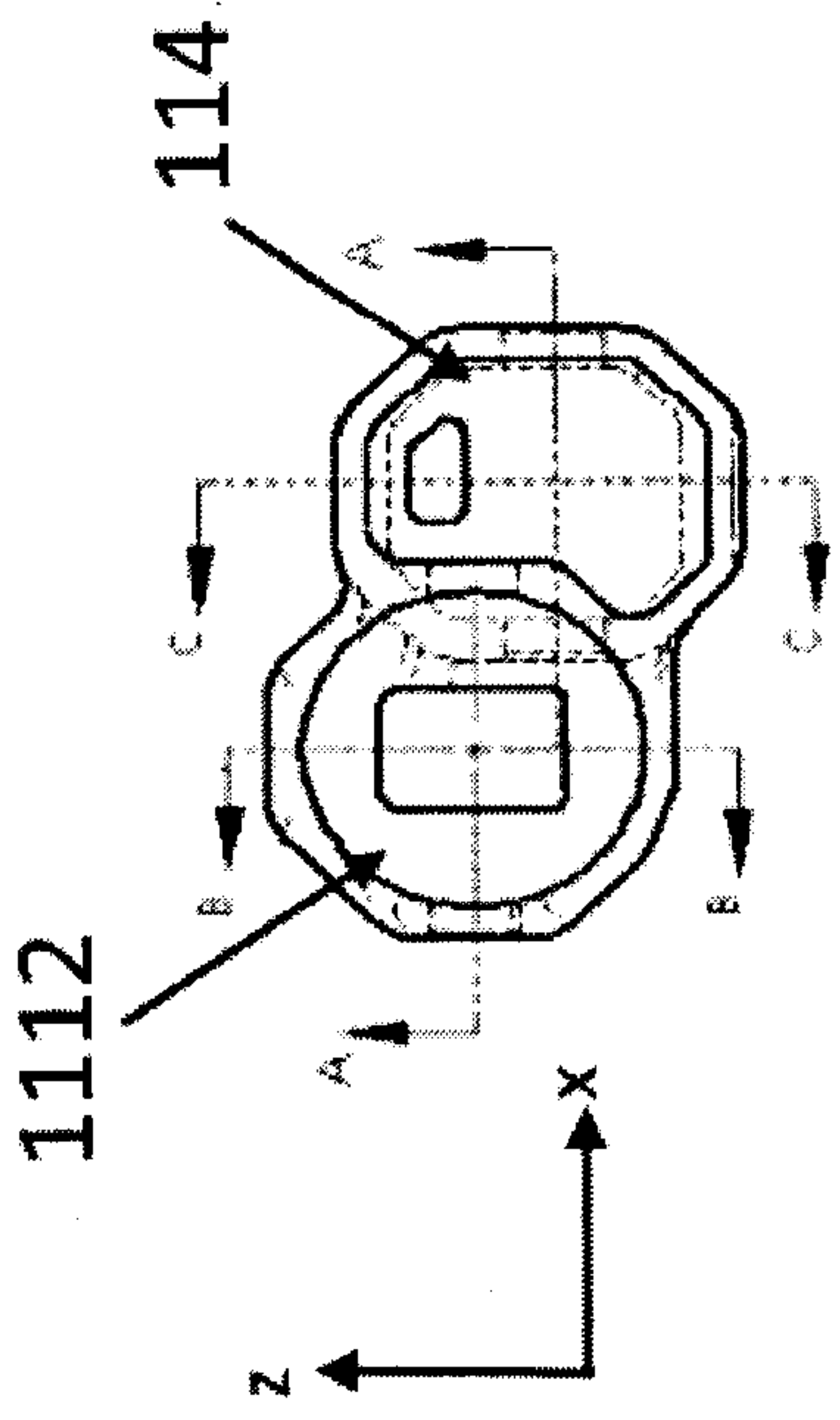

FIG. 8

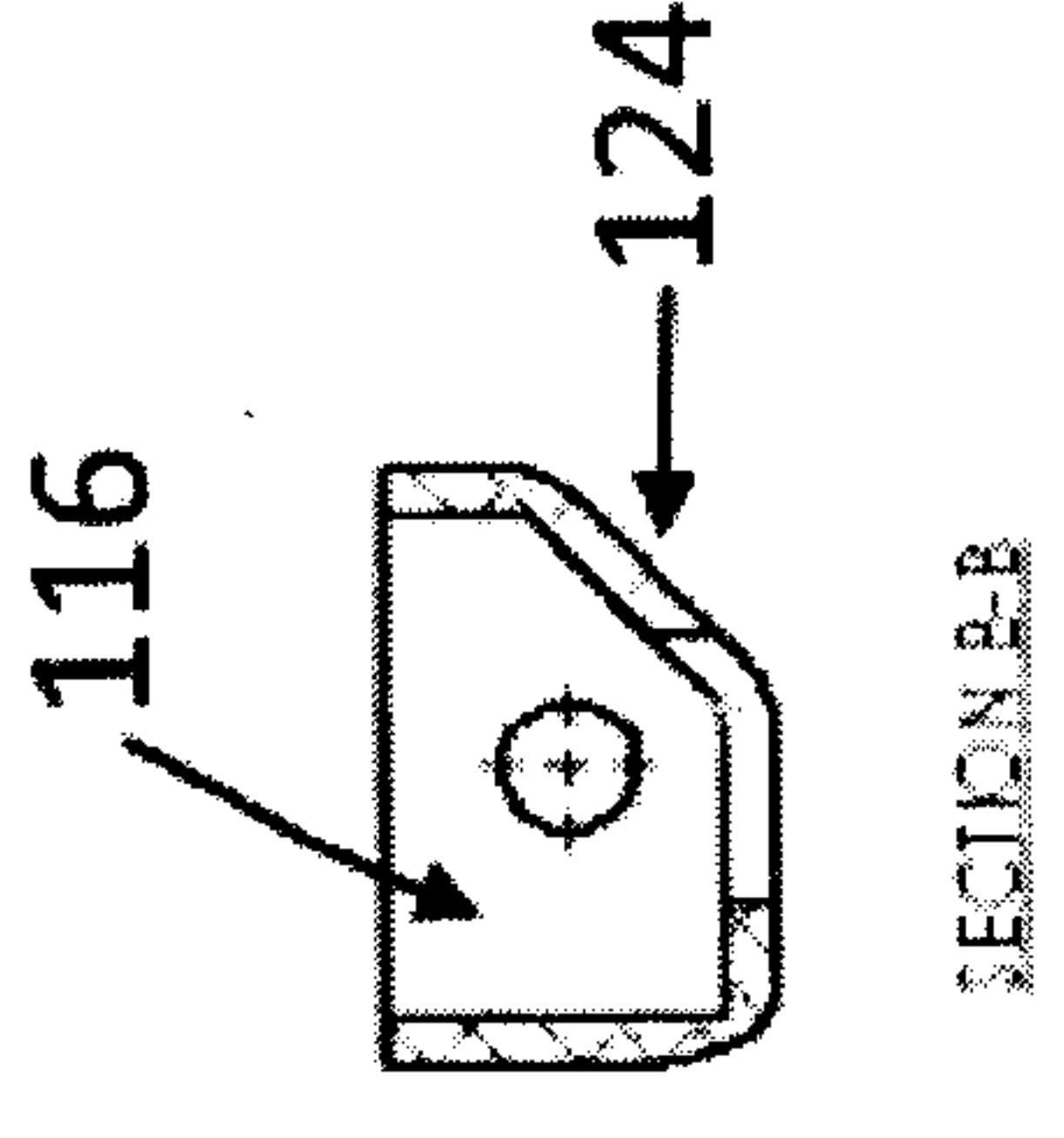

FIG. 9

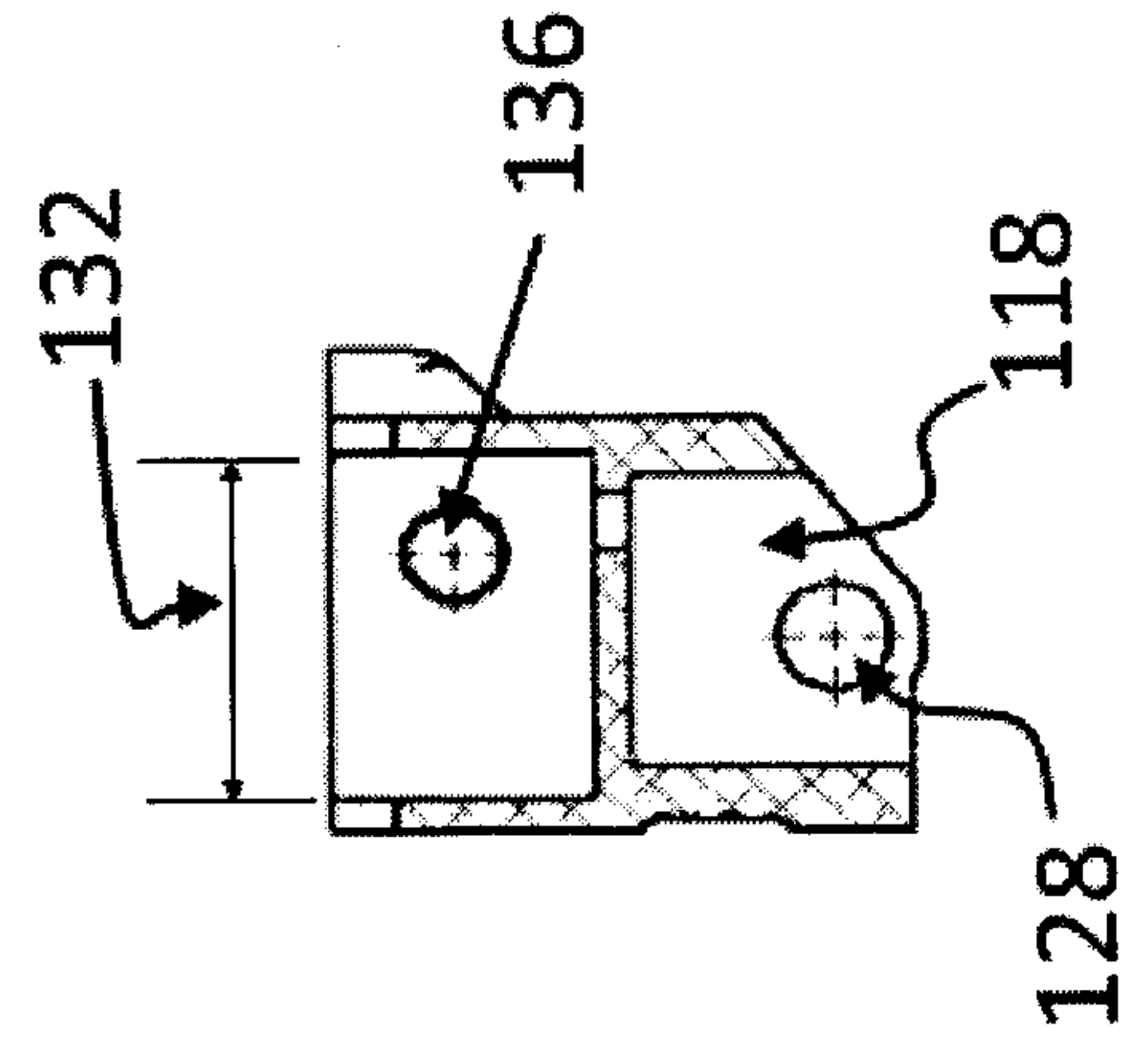

FIG. 11

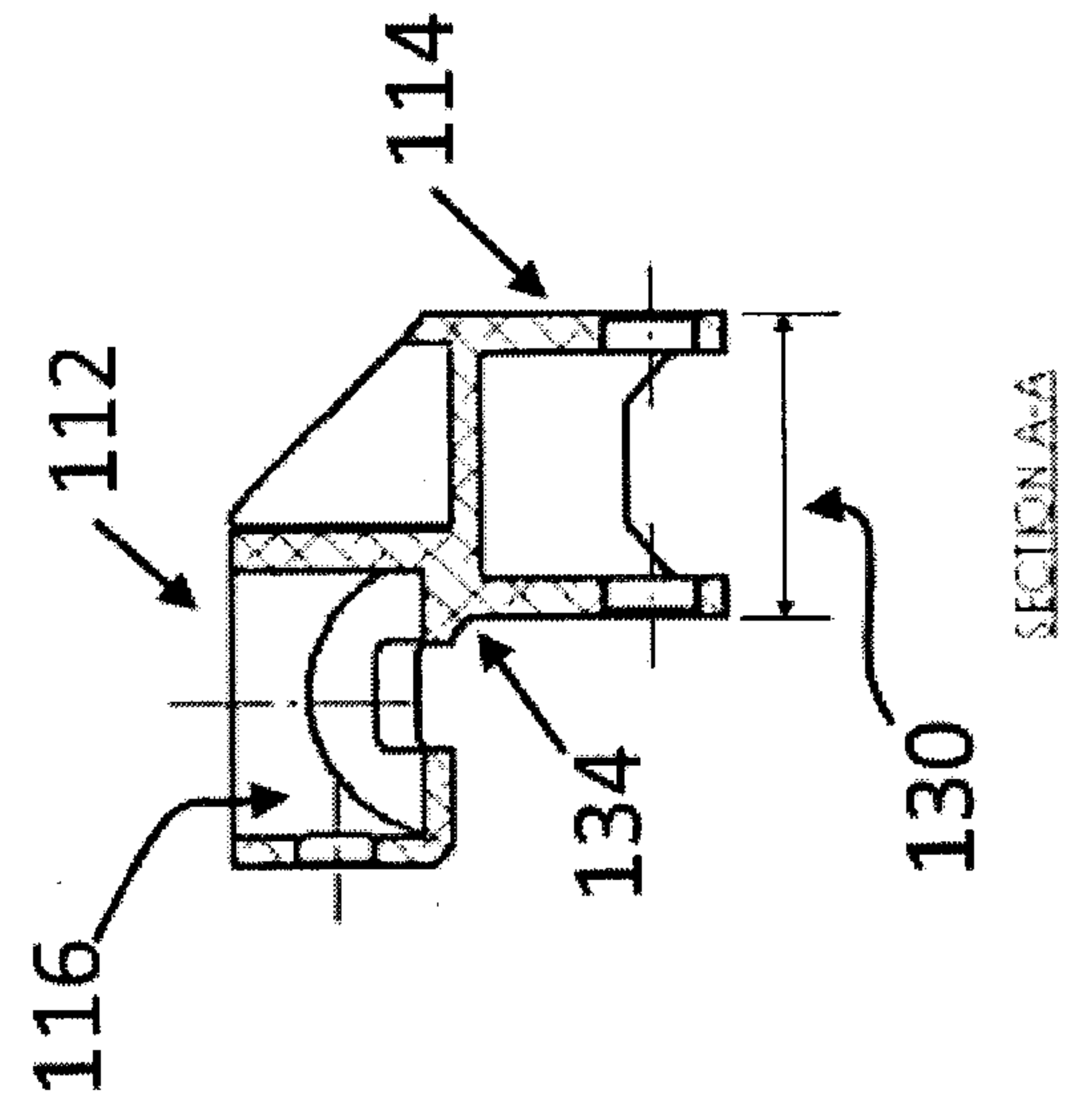

FIG. 10

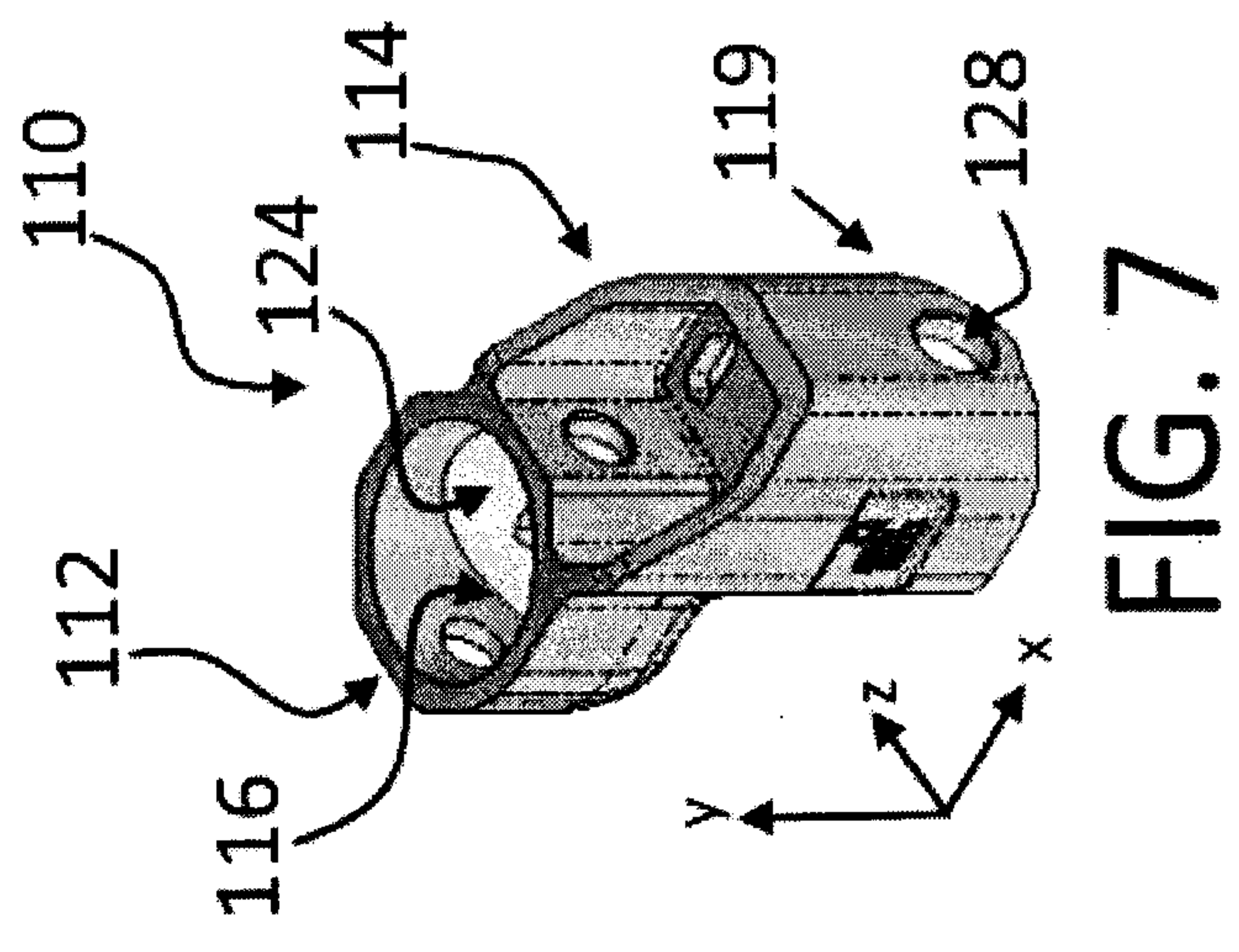

FIG. 7

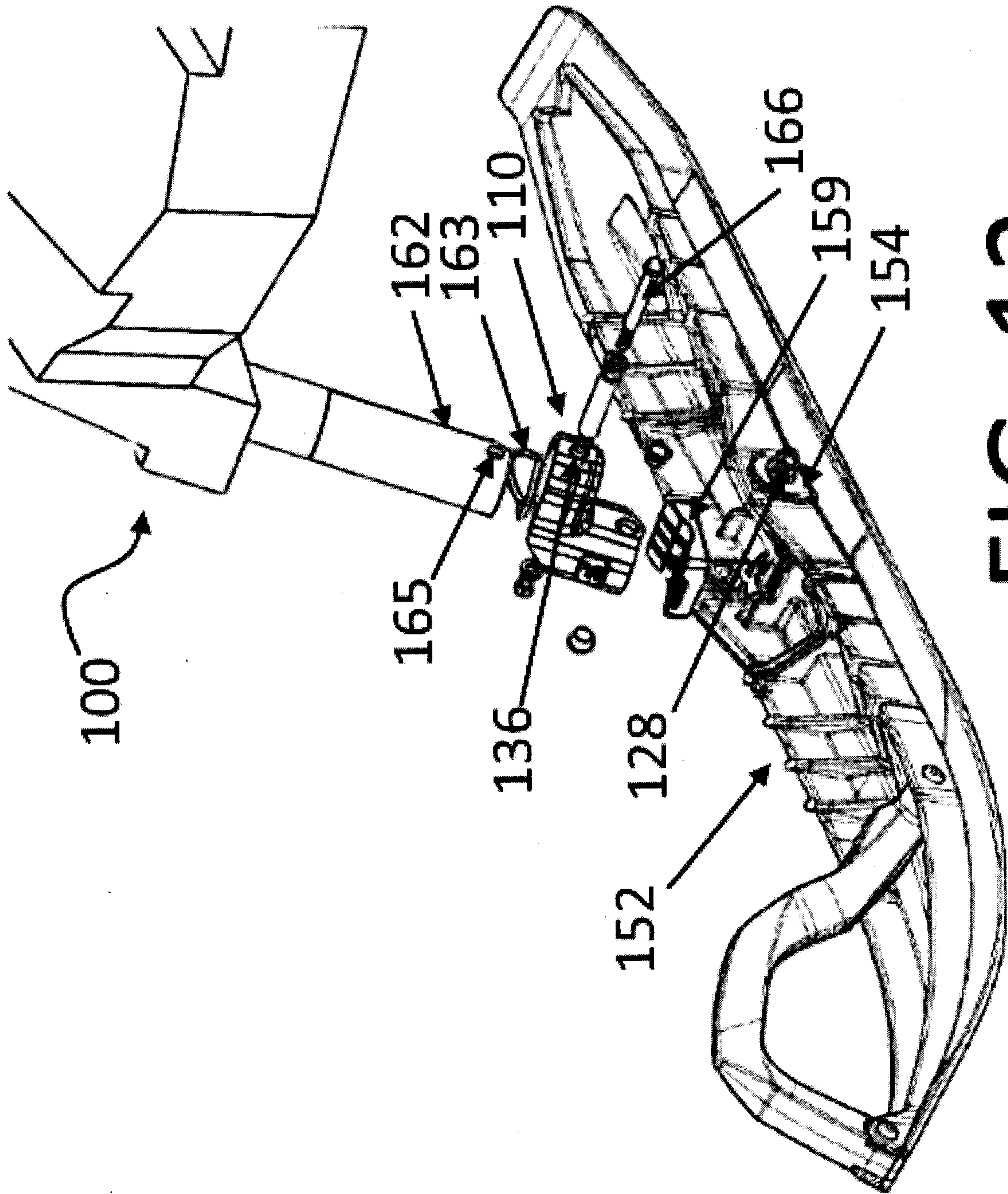

FIG. 12

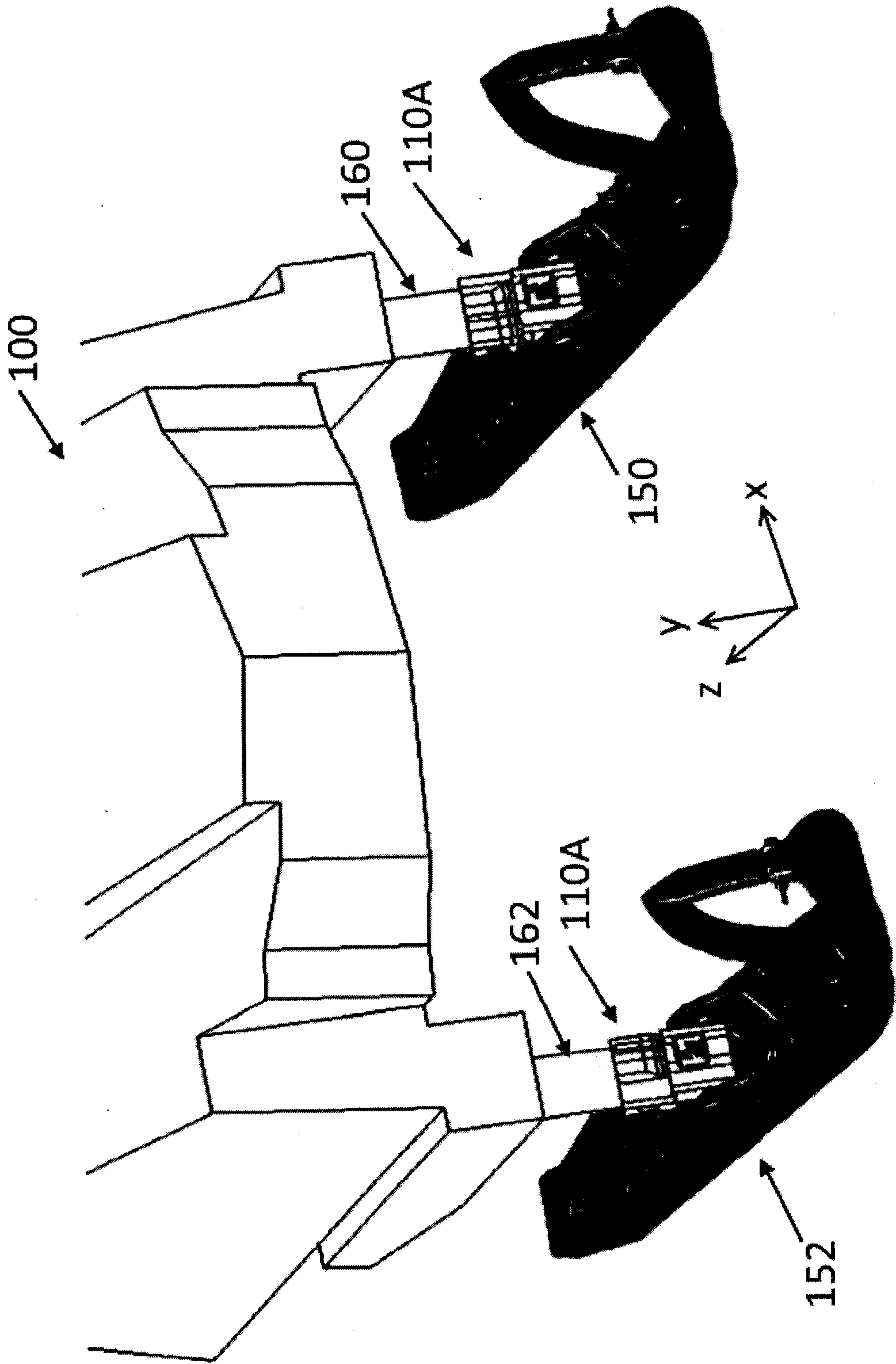

FIG. 13

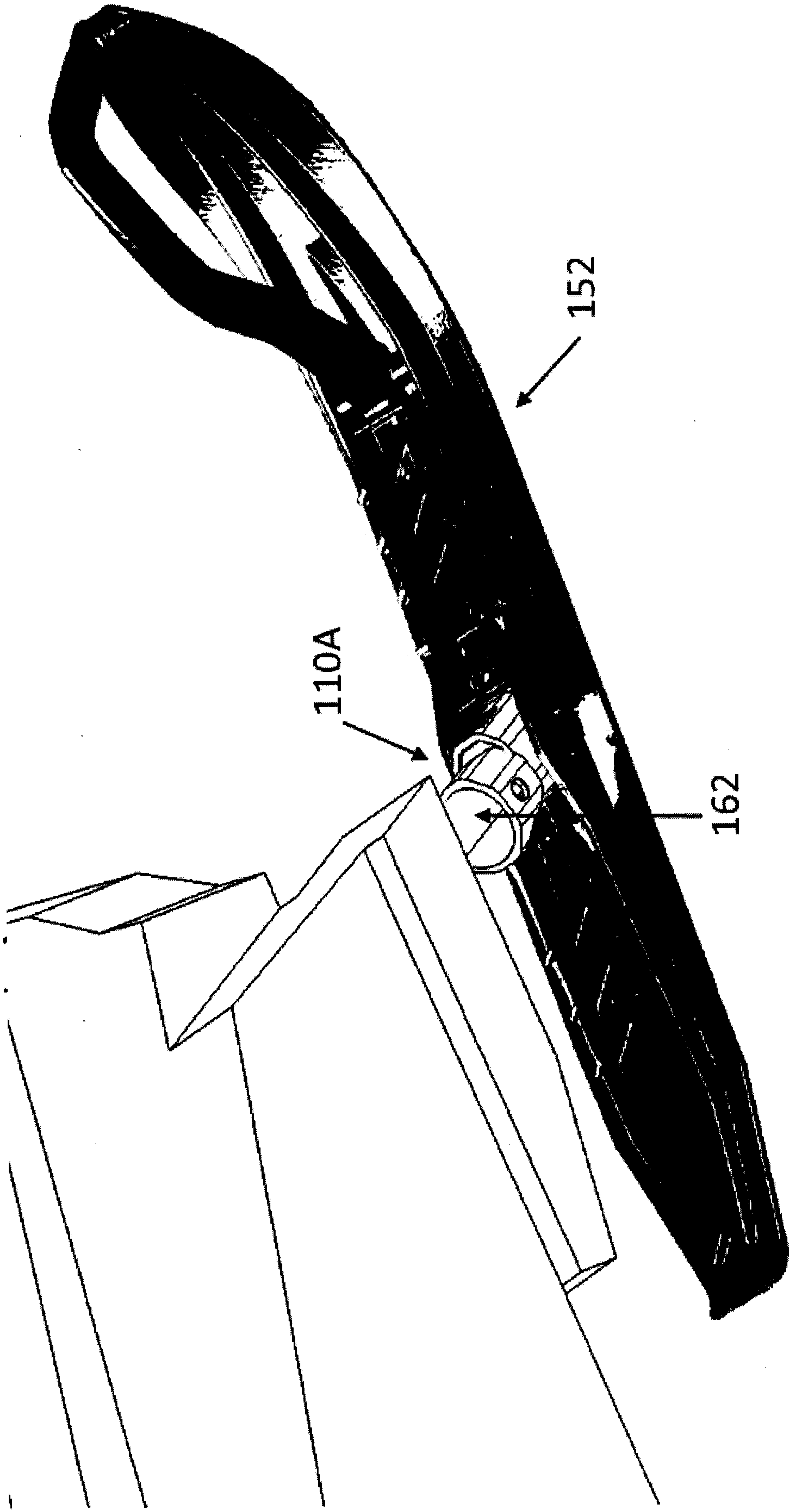

FIG. 14

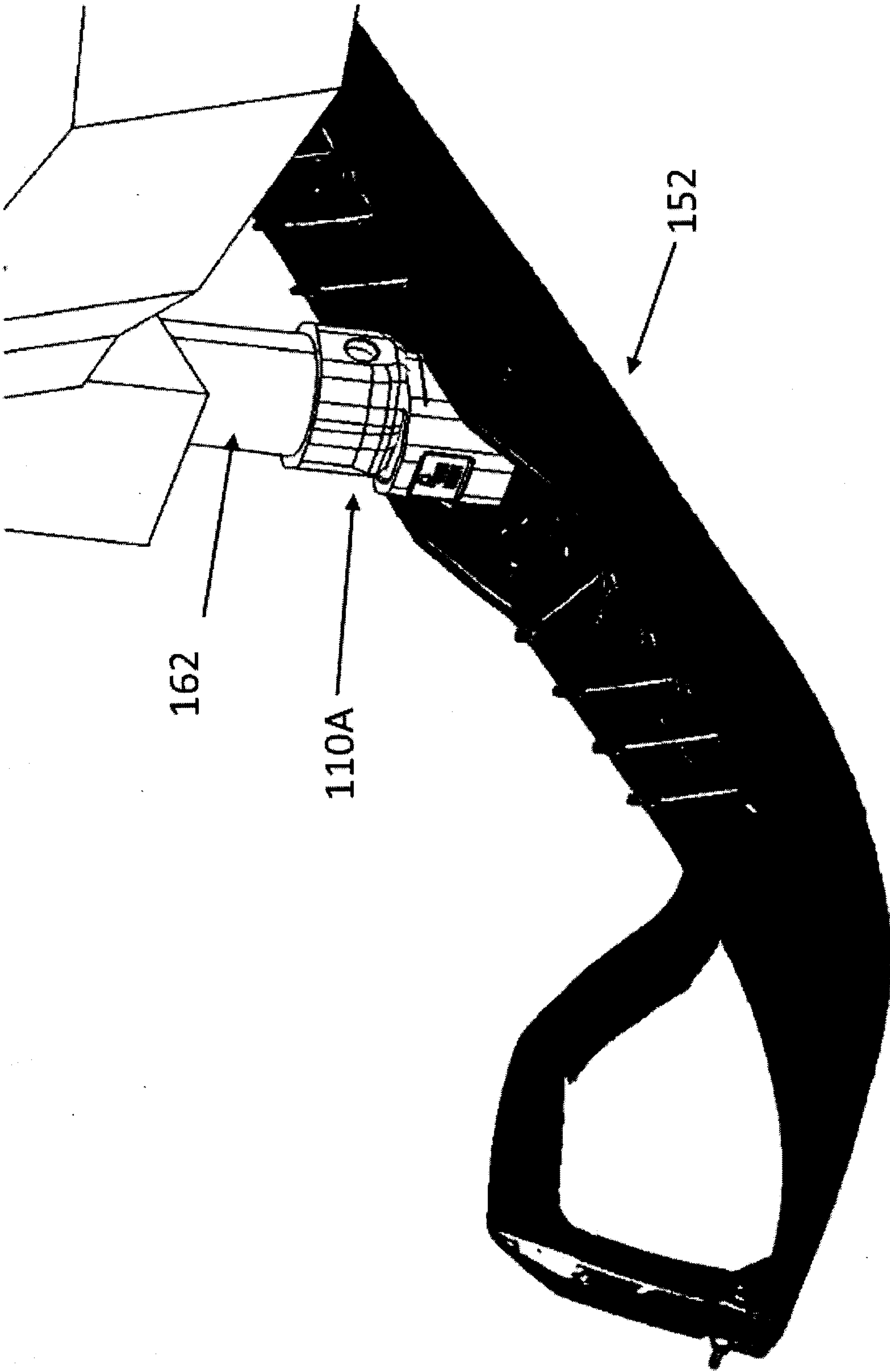

FIG. 15

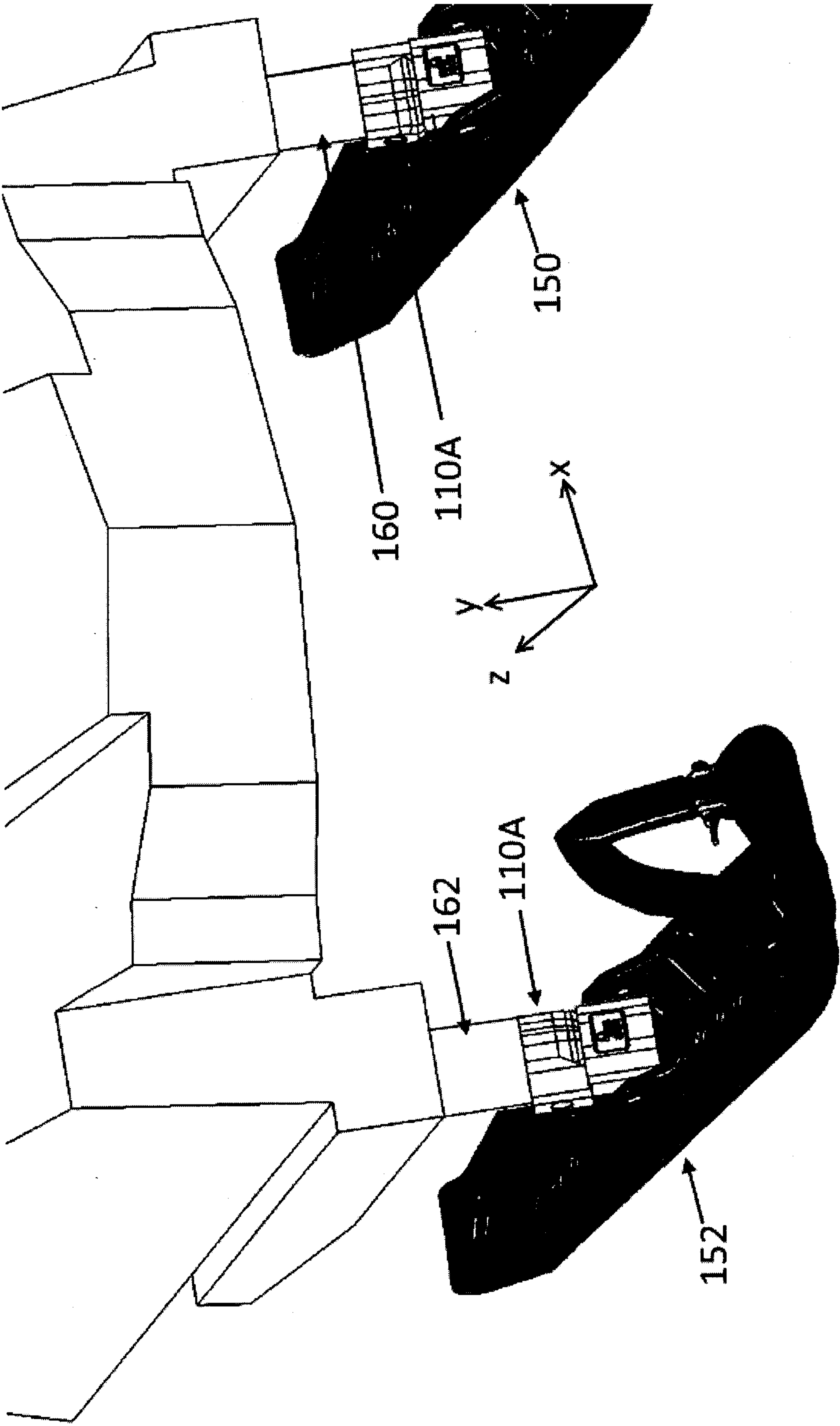

FIG. 16

