

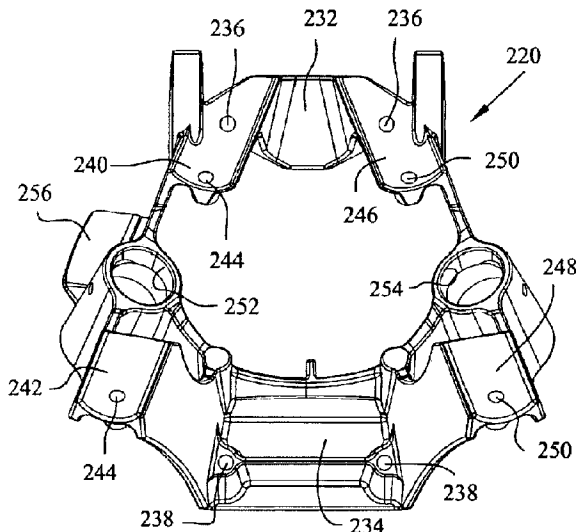

(22) Date de dépôt/Filing Date: 2010/12/16  
 (41) Mise à la disp. pub./Open to Public Insp.: 2011/08/18  
 (45) Date de délivrance/Issue Date: 2020/10/27  
 (62) Demande originale/Original Application: 2 788 551  
 (30) Priorités/Priorities: 2010/02/08 (US61/302394);  
 2010/02/09 (US61/337676)

(51) Cl.Int./Int.Cl. *B62D 55/07* (2006.01),  
*B62D 55/06* (2006.01)  
 (72) Inventeurs/Inventors:  
 CONN, JEFFREY D., US;  
 MILLS, ANDREW J., US;  
 MERTENS, DUSTIN A., US;  
 RIPLEY, ANTHONY J., US;  
 DAHLGREN, LYLE J., US;  
 SAMPSON, MARTIN E., US  
 (73) Propriétaire/Owner:  
 POLARIS INDUSTRIES INC., US  
 (74) Agent: MARKS & CLERK

(54) Titre : CHASSIS DE MOTONEIGE ET CONNECTEUR  
 (54) Title: SNOWMOBILE FRAME AND CONNECTOR



(57) **Abrégé/Abstract:**

Alternative configurations for frames and connectors for snowmobiles may be desired. Accordingly, there is provided a frame for a snowmobile. The frame comprises a plurality of frame members and a coupling to receive the plurality of frame members. The coupling includes a first open channel, a second open channel and at least one cylindrical member for receiving the plurality of frame members. The coupling is operatively coupled to a lower portion of a steering post of a steering assembly, wherein a forward-most end of the at least one cylindrical member is positioned forward of a forward-most end of the lower portion of the steering post, and the steering assembly is mounted to the coupling at a substantially upright angle. A connector for a snowmobile is also provided comprising a coupling member having a frame portion for securing frame members thereto and a steering portion for coupling a steering assembly thereto.

### ABSTRACT

Alternative configurations for frames and connectors for snowmobiles may be desired. Accordingly, there is provided a frame for a snowmobile. The frame comprises a plurality of frame members and a coupling to receive the plurality of frame members. The coupling includes a first open channel, a second open channel and at least one cylindrical member for receiving the plurality of frame members. The coupling is operatively coupled to a lower portion of a steering post of a steering assembly, wherein a forward-most end of the at least one cylindrical member is positioned forward of a forward-most end of the lower portion of the steering post, and the steering assembly is mounted to the coupling at a substantially upright angle. A connector for a snowmobile is also provided comprising a coupling member having a frame portion for securing frame members thereto and a steering portion for coupling a steering assembly thereto.

## SNOWMOBILE FRAME AND CONNECTOR

The present disclosure generally relates to snowmobiles. More particularly, the present disclosure relates to the components of a snowmobile such as the frame, suspension, running boards and various other assemblies.

5 Generally, there are a variety of configurations of snowmobiles available for applications such as deep snow, high performance, luxury touring, trail riding, etc. Most snowmobiles include a frame, a power train, a pair of front skis, and an endless belt assembly. Typically, features such as engine displacement and track length vary depending upon the specific application for which the snowmobile is targeted. For  
10 example, snowmobiles designed primarily for deep snow application may include an endless belt assembly having a longer track length, i.e. 166 inches (4.2 meters), than a snowmobile designed primarily for trail riding, i.e. 135 inches (3.4 meters). A snowmobile designed for deep snow may also include a relatively large displacement engine, i.e. 900 cc<sup>3</sup> (54.9 inches<sup>3</sup>), to provide suitable power when operating in a  
15 mountain environment at higher elevations with less oxygen. Other features of a deep snow snowmobile may be added to improve ride and handling characteristics such as side hilling.

One illustrative embodiment of the present disclosure includes a snowmobile comprising a frame, a power train supported by the frame; a running board assembly  
20 supported by the frame and comprising a toe clip, a front wall and a foot tread; and a shroud laterally encompassing the toe clip and the back wall, with the toe clip extending rearwardly, beyond a rear edge of the shroud.

Another illustrative embodiment of the present disclosure includes a frame; a power train supported by the frame; a running board assembly supported by the frame and  
25 comprising a toe clip, a front wall and a foot tread; and a shroud laterally encompassing the toe clip and the back wall, with the back wall extending substantially aligned with a rear edge of the shroud.

Another illustrative embodiment of the present disclosure includes a snowmobile comprising: a frame; a power train supported by the frame; and a running board  
30 assembly supported by the frame and comprising a toe clip, a front wall and a foot tread; the foot tread having upturned embossed openings having gripping surfaces thereon.

Another illustrative embodiment of the present disclosure includes a snowmobile comprising a frame; a power train supported by the frame; and a running board assembly supported by the frame and comprising a toe clip, a front wall and a foot tread; the foot tread having upturned embossed openings and openings through the running board.

Another illustrative embodiment of the present disclosure includes a snowmobile comprising a frame; a power train supported by the frame; a running board assembly supported by the frame and comprising a toe clip, a front wall and a foot tread; and a shroud laterally encompassing the toe clip and the back wall, with the back wall extending substantially aligned with a rear edge of the shroud.

Another illustrative embodiment of the present disclosure includes a frame for a snowmobile, the frame comprising a plurality of frame members; and a coupling to receive the plurality of frame members, the coupling includes a first open channel, a second open channel and at least one cylindrical member for receiving the plurality of frame members, the coupling being operatively coupled to a lower portion of a steering post of a steering assembly, wherein a forward-most end of the at least one cylindrical member of the coupling is positioned forward of a forward-most end of the lower portion of the steering post, and the steering assembly is mounted to the coupling at a substantially upright angle.

Another illustrative embodiment of the present disclosure includes a connector for a snowmobile, the connector comprising: a coupling member having a frame portion for securing a plurality of frame members thereto and a steering portion for coupling a steering assembly thereto, the frame portion including a first channel, a second channel, a first cylindrical member, and a second cylindrical member for receiving the plurality of frame members, the first channel including an upper portion having a first upper-most surface and a lower portion, and the second channel including an upper portion having a second upper-most surface and a lower portion, and the steering portion including a first web and a second web for receiving a steering post of the steering assembly, the first web including an upper-most surface directly coupled to the first upper-most surface of the first channel and the second upper-most surface of the second channel such that the upper-most surfaces of the first web, the first channel, and the second channel define a continuous outer surface of an upper portion of the coupling member, and the second web extending between the lower portion of the first channel and the lower portion of the second channel.

The above mentioned and other features of this disclosure, and the manner of attaining them, will become more apparent and will be better understood by reference to the following description of embodiments taken in conjunction with the accompanying drawings.

- 5 Fig. 1 is a front perspective view of an illustrative embodiment of a snowmobile;
- Fig. 2 is a rear perspective view of the embodiment shown in FIG. 1;
- Fig. 3 is a side view of the left-hand side of the embodiment shown in FIG. 1;
- Fig. 4 is a side view of the right side of the embodiment shown in FIG. 1;

- Fig. 5 is a top view of the embodiment shown in FIG. 1;
- Fig. 6 is a front view of the embodiment shown in FIG. 1;
- Fig. 7 is a rear view of the embodiment shown in FIG. 1;
- Fig. 8 is a bottom view of the embodiment shown in FIG. 1;
- 5 Fig. 9 is an enlarged view of the running board assembly of the embodiment shown in FIG. 1;
- FIG. 10 is an enlarged view of the foot tread of the embodiment shown in FIG. 1;
- FIG. 11 is an enlarged side view of a front portion of the running board;
- FIG. 12 is an exploded view of the tunnel;
- 10 FIG. 13 is an enlarged view of the rear snow flap;
- FIG. 14 is a partial front perspective view of the snowmobile with the front body removed;
- FIG. 15 is an enlarged front perspective of the front frame;
- FIG. 16 is a front perspective of the cast frame member;
- 15 FIG. 17 is an underside perspective view of the cast frame member of FIG. 16;
- FIG. 18 is a rear view of the cast frame member;
- FIG. 19 is a front perspective view of the steering assembly;
- FIG. 20 is a side view of the steering assembly mounted to the cast frame member of FIG. 16;
- 20 FIG. 21 is a side perspective view of a heat shield member mounted to an inside of the body panel; and
- FIG. 22 is an exploded perspective view of the air intake system;
- FIG. 23 is a side showing the suspension system removed from the tunnel; and

FIG. 24 shows an exploded view of a rear bumper.

Corresponding reference characters indicate corresponding parts throughout the several views. Although the drawings represent embodiments of the present invention, the drawings are not necessarily to scale and certain features may be  
5 exaggerated in order to better illustrate and explain the present invention.

The embodiments disclosed below are not intended to be exhaustive or to limit the invention to the precise forms disclosed in the following detailed description. Rather, the embodiments are chosen and described so that others skilled in the art may utilize their teachings. For example, while the following description refers primarily to  
10 a snowmobile, it should be understood that the principles of the invention apply equally to other snow vehicles. While the present invention primarily involves a snowmobile, it should be understood, however, that the invention may have application to other types of vehicles, such as motorcycles, ATVs, utility vehicles, scooters, and mopeds.

15 Referring to FIGS. 1-8, one illustrative embodiment of a snowmobile 10 is shown. Snowmobile 10 includes a frame 12, supported by front skis 14 and by endless belt assembly 16. Front skis are coupled to a front suspension 18, and endless belt assembly is supported by a rear suspension 20. Snowmobile also includes a seat assembly 22, front outer body 24, and a steering assembly 26. Steering assembly  
20 26 is operably coupled to steering arms 28 (FIG. 2) which allows a rider to steer snowmobile 10. A power train is covered by outer body 24 and provides power to endless belt assembly 16. Running board assemblies 32 extend along the sides of the seat assembly which are supported by the frame 12. A snow flap 34 (FIG. 2) is also supported by the frame rearward of the endless belt.

25 With reference to FIGS. 1 and 2, frame 12 includes a tunnel 40 having a top wall 42 and side walls 44. As shown best in FIG. 2, endless belt 16 at least partially runs up into tunnel 40 between side walls 44 and upwardly towards top wall 42. As shown, running board assemblies 32 include a rider's foot grip assembly 50 (FIG. 4) and a foot tread assembly 52, where the foot grip assembly 50 and foot tread assembly 52  
30 are supported by the tunnel sidewall 44. As shown best in FIGS. 11 and 12, the tunnel 40 also include a plurality of cutout portions 46 which reduce the material in

locations where fasteners are not needed. These cutouts 46 help to reduce the weight of the entire vehicle. The surface to which sidewalls 44 abut (not shown), also include notches but complement notches 46 such that the notches do not overlap. Other cutouts could be provided elsewhere as well.

- 5 With reference now to FIG. 9, the foot grip assembly 50 is shown in greater detail. Foot grip assembly 50 includes frame member 100 which extends over the top wall 42 of tunnel 40, having a first portion 102 extending downwardly and away from the tunnel, and a second portion 104 extending downwardly and reversely bent towards the tunnel. The end of portion 104 is flattened and includes a flange at 106. Foot
- 10 grip assembly 50 further includes a tube portion 110 which is fastened to the side of the tunnel and connected to frame portion 100 for example, by welding. A toe clip 112 extends between frame member 110 and frame portion 102. Finally, foot grip assembly 50 includes a back wall 114 attached at marginal edges 115 and 116, and comprises plural slotted openings 118.
- 15 With reference to FIGS. 9-12, foot tread assembly 52 is comprised of an elongate frame member 122 and running board plate 124. Elongate frame member 122 is comprised of a tube 126 and a frame bracket 128. As shown in FIG. 12, frame bracket 128 is discreet from tube 126. Bracket 128 includes a bracket foot 130 which extends into tube 126 and a bracket arm 132 for attachment to flange 106.
- 20 Bracket foot 130 may be attached to tube 126 by way of fasteners, welding or adhesives, or a combination thereof. As shown (FIG. 9), the flattened surfaces of flanges 106 and bracket arms 132 are positioned back to back and attached by way of fasteners 134 (FIG. 9). Furthermore, the planes of the flat surfaces of flanges 106 and bracket member 132 extend in a longitudinal direction as described herein.
- 25 With respect now to FIGS. 9 and 10, running board plate 124 is comprised of a plate portion 140 having a lip 142 positioned and attached to elongate tube member 126 as shown. The opposite side of the plate portion 140 has a marginal edge 144 which is attached to the tunnel side wall 44. As shown in Figure 12, the running board plate 124 is integral with the tunnel side wall 44, however this connection could also
- 30 be by fastening, such as by welding, adhesives or riveting.

The running board plate 124 further includes a plurality of upturned embossments 150 (FIG. 10) having a generally triangular shape with gripping serrations 152 positioned thereon. Intermediate each of the upturned embossments 150 is an opening 156, of reverse triangular shape, where the embossments 150 rigidify the plate portion 140 whereas openings 156 maximize the open area of the foot tread to allow snow to drop downwardly therethrough. This provides a smooth bottom surface to plate portion 140, having no interference with the snow.

Thus, as shown in FIG. 9, an enlarged ventilation area is defined by the spacing at 160 and within the slots 118. The longitudinal disposition of the flanges 106 and 132 as described above also maximizes the ventilation area 160, particularly for the removal heat from the engine compartment as described herein.

Finally, with respect to FIGS. 9-11, an outer shroud 180 covers foot grip assembly 50 and includes a shroud portion 182 which encompasses portions 102 and 104 of frame tube 100. Shroud 180 also includes a rear edge 184 (FIG. 11) which is proximate to back wall 162. As shown best in FIG. 11, toe clip 112 extends rearwardly beyond rear edge 184 of shroud 180 which provides easy access for the rider to place their boot in the toe clip, yet prevents forming a pocket into which snow may accumulate and pack. Also, the forward angle of edge 184 allows a rider's foot to position sideways, overlapping the foot tread assembly 52, and yet stay retained behind foot grip assembly 50.

With reference now to FIG. 13, snow flap 34 is shown in an enlarged view. Snow flap 34 is hinged to the tunnel 40 along a rear edge 190. The snow flap 34 includes a plurality of apertures 192 which reduces the overall weight of the component. These could be machined or molded in.

With reference now to FIG. 14, the outer body 24 has been removed which better exposes the engine compartment 200, the steering assembly 26, the frame front portion 202, and the power train 204. The power train 204 includes an engine 206 having an exhaust system 208, an intake system 210 and a drive system including a CVT 212. As mentioned above, the ventilation area 160 was defined around the foot grip area, and this allows the CVT ventilation to exhaust through ventilation area 160.

With reference now to FIG. 15, the front portion 202 of the frame is shown in greater detail. Front portion 202 includes a cast coupling or connector 220 configured to attach plural frame tubes, namely front frame tubes 222, 224 and rear frame tubes 226 and 228 thereto. The frame tubes 222, 224, 226, 228 may be attached to the cast coupling 220 by way of fasteners such as 230 and/or may be adhesively fixed to the cast coupling 220. As shown, the cast coupling 220 further includes two support webs 232 and 234. Each of the webs is provided with threaded apertures, for example, 236 and 238. As also shown in FIG. 15, a steering post 260 of steering assembly 26 is directly coupled to webs 232 and 234 of the cast coupling 220, as described herein.

With reference now to FIGS. 16-18, cast coupling 220 will be described in greater detail. Cast coupling 220 further includes a first circular channel (FIG. 16) defined by portions 240 and 242 having threaded bosses 244 extending downwardly therethrough. A second circular channel is defined by portions 246 and 248 having threaded bosses 250 therein. The circular channels are intersected by cylindrical members 252 and 254. Thus, with a comparison of FIGS. 15 and 16, it should be appreciated that frame tubes 222 and 224 are positioned across the circular channels with fasteners such as 230 positioned through the frame tubes 222, 224 and into the threaded bosses 244, 250. Adhesive may also be applied. Meanwhile, frame tubes 226 and 228 are positioned in the cylindrical members 252 and 254, and may also be fixed in place by way of fasteners and adhesive.

With reference now to FIG. 18, cast coupling 220 includes machined mounting surfaces 232A and 234A on the backside of the webs 232 and 234, respectively, for mounting the steering post as described below. Finally as best shown in FIG. 17, cast coupling 220 includes an integral fuel tank mounting tab shown at 258.

With reference now to FIG. 19, the steering assembly is shown in greater detail. As shown, steering post 260 includes an upper and lower bearing posts 270 and 272 which attach to the backside of the webs 232, 234 respectively, with fasteners being attached to threaded apertures 236 and 238, respectively. This rigidly connects the steering post 260 to the cast coupling 220 yet allows the steering post to pivot about the corresponding bushings 270 and 272. As also shown, handlebars 276 of

steering assembly 26 are attached to the steering post 260 by way of a clamp at 278.

Steering assembly 26 further comprises a lower steering post 280 which is operatively coupled to steering post 260 by way of respective link arms 282, 284, 5 connected together by way of a link 286. Lower steering post 280 is ultimately connected to steering arms 28 by way of a further steering arm, not shown, to maneuver the steering skis 14.

With reference now to FIG. 20, steering assembly 26 is shown mounted to the backside of cast coupling 220 with the bushings 270, 272 (FIG. 19) mounted to the 10 surfaces 232A, 234A (FIG. 18), respectively. As shown, steering post 260 is nearly vertical and could be in the range where angle  $\emptyset$  could be between 0 and 15 degrees and as shown is about 13 degrees. As steering post 260 is positioned at a substantially upright angle, the ergonomics is improved for the deep snow rider.

As known, when side hilling, a rider is often standing on only one side of the running 15 board assemblies 32 and the maneuverability of the steering post and handlebars 276 is substantially increased when the steering post 260 is close to vertical. This prevents the handlebars 276 from dipping down or raising up on either side when attempting to steer the snowmobile while standing on only one side.

FIG. 20 also shows a fuel tank 258 having a front end positioned adjacent to the 20 integral fuel tank mounting tab 256 to retain a front end of the fuel tank 258. Fuel tank 258 may be attached to tab 256 through fasteners, or fuel tank could have a molded slot to be applied over tab 256.

With respect now to FIG. 21, front side panel 300 (see also FIG. 4) on the right hand side of the snowmobile is provided with sound insulation 302 as well as a heat shield 25 304. The foam includes a front surface 306, a back surface 308, and a plurality of cutouts 310 extending between the front and back surface. Heat shield 304 includes a plate 320 having a plurality of mounting feet 322 which correspond in location to the apertures 310. An adhesive is provided against the back surface 308 to retain sound insulation to the inside surface of the panel 300. Heat shield 304 can be 30 placed with the feet 322 aligned with the associated apertures 310 and pressed against the foam 302 until the feet contact the adhesive, through the apertures,

which retains the heat shield to the foam member 302. This prevents any fasteners or additional dimensional requirements for attaching the heat shield to the foam. This also provides less weight for the snowmobile yet provides a heat shield 304 adjacent to a portion of the exhaust system of the snowmobile power train as described above. The adhesive could be a double-sided sticky tape, double sided foam tape, or any other adhesive for the purposed described.

Referring now to FIG. 22, air inlet 210 (FIG. 15) is shown in greater detail as comprised of inlet housing 350, retainer housing 352 and sound-deadening foam 354. Housing 350 is generally rectangular having a plurality of apertures 356 extending therethrough, where the rectangular housing has a front wall 360, sidewall 362 opposite side wall 366 and rear wall 368. Retainer 352 includes a front wall 370, sidewall 372 having lugs 374, opposite sidewall 376 and a partial rear wall 378. Sound-deadening foam 354 generally includes a foam body portion 380 having locating apertures at 382.

It should be appreciated that the foam 354 is positioned on an inside of the retainer member 352 with lugs 374 aligned with apertures 382 of the foam 354. The retainer and foam together are then snapped around housing 350 with the front wall 370 of retainer 352 positioned against front wall 360 of housing 350, sidewalls 372 and 376 positioned adjacent to corresponding sidewalls 362 and 366, respectively, and with partial wall 378 at retainer 352 positioned against back wall 368. The retainer 352 and housing 350 can be held together by way of corresponding latch members such as lug 390 and aperture 392 to retain the two components together. This provides an easy to assemble two component intake system 210 having an internal housing 350 and a retainer housing 352 whereby air traveling through the intake system can be sound-deadened by foam member 354.

With reference now to FIG. 23, rear suspension 20 is shown removed from the tunnel, understanding that the rear suspension is attached to the underside of tunnel 40. Suspension 20 includes a frame 400 having laterally spaced frame rails 402 with slide rails 404 attached thereto. Suspension 20 includes two coil over shocks 406 and 408 providing dampening between the tunnel 40 and frame 400. A track roller 410 is mounted on the outside of the slide rail 402, and as shown, has an outer radial surface 412 which extends beyond lower surface 414 of slider 404. Track

rollers 410 are located at a position proximate a maximum pressure point between the sliders 404 and track (absent the track wheel) which allows the track a slight spacing between the sliders 404 preventing substantial frictional heating.

Suspension 20 also includes idler rollers 420 and 422. Scratchers 426 are also  
5 provided on the side of frame 404 to break up crusted snow in order that the track can throw snow against the underside of tunnel 40, as the tunnel includes a heat exchanger for engine water.

With reference now to FIGS. 13 and 24, a rear bumper assembly 450 is shown including a rear bumper member 452 and side brackets 454. Bumper member 452  
10 is comprised of a carbon fiber material and as best shown in FIG. 24 has an outer diameter 456, an inner diameter 458, and apertures 460. Side brackets 454 are comprised of an extruded aluminum and include apertures 462 for mounting the side brackets to tunnel 40 by way of fasteners 464 (FIG. 13). As shown, extruded  
15 brackets 454 have extruded openings at 466 and apertures 468 which extend into openings 466. A cap 470 is also provided having a lip 472, and a reduced diameter portion 474 having apertures 476.

To assemble bumper assembly 450, bumper member 452 is positioned in openings 466 of extruded members 454. Caps 470 are positioned with diameter portions 474  
20 within inner diameter 458 and with the lips 472 against the extruded side bracket 454, with apertures 460 and 476 aligned. Fasteners 480 are then placed through the extruded members 454, bumper member 452 and cap 470 to retain the bumper member thereto. Fasteners 464 could be set screws, bolts, rivets or any similar  
25 fastening device, although as shown, fasteners 480 are rivets. As also shown in FIG. 13, snow flap 34 includes a stop member 490 integrally molded with the flap which has an upper stop surface 492 which abuts against the bumper member 452.

It should be generally understood that the description provided herein relates only to the specific embodiment, and that other variations could be envisioned. For example, while referring herein to tubes, cylindrical tubes are shown, but it is contemplated  
30 that other structural geometries, such rectangular or square tubes could also be used.

While this invention has been described as having an exemplary design, the present invention may be further modified within the spirit and scope of this disclosure. This application is therefore intended to cover any variations, uses, or adaptations of the invention using its general principles. Further, this application is intended to cover  
5 such departures from the present disclosure as come within known or customary practice in the art to which this invention pertains.

**What is claimed is:**

1. A frame for a snowmobile, the frame comprising a plurality of frame members; and a coupling to receive the plurality of frame members, the coupling includes a first open channel, a second open channel and at least one cylindrical member for receiving the plurality of frame members, the coupling being operatively coupled to a lower portion of a steering post of a steering assembly, wherein a forward-most end of the at least one cylindrical member of the coupling is positioned forward of a forward-most end of the lower portion of the steering post, and the steering assembly is mounted to the coupling at a substantially upright angle.
2. The frame of claim 1, wherein the coupling is cast.
3. The frame of claim 1 or 2, wherein the steering post is operatively coupled to at least one web of the coupling.
4. The frame of any one of claims 1 to 3, wherein the steering assembly is coupled to the coupling at an angle between 0 and 15 degrees.
5. The frame of any one of claims 1 to 4, wherein each of the frame members is attached to the coupling with at least one of adhesive and fasteners.
6. The frame of any one of claims 1 to 5, wherein the coupling includes a first web and a second web for receiving the steering post of the steering assembly.
7. The frame of claim 6, wherein the at least one cylindrical member comprises a first cylindrical member and a second cylindrical member, and wherein the first open channel is intersected by the first cylindrical member and the second open channel is intersected by the second cylindrical member.
8. The frame of claim 6 or 7, wherein the first open channel includes an upper portion and a lower portion, and the second open channel includes an upper portion and a lower portion, the first web extending between the upper portion of the first channel and the upper portion of the second channel, and the second web extending between the lower portion of the first channel and the lower portion of the second channel.

9. The frame of any one of claims 1 to 8, wherein the coupling includes a tab for mounting a fuel tank to the coupling.
10. The frame of claim 9, wherein the tab is integral with the coupling.
11. The frame of any one of claims 1 to 6, wherein at least a portion of one of the first and the second open channels is vertically aligned with a portion of the at least one cylindrical member.
12. A connector for a snowmobile, the connector comprising:
  - a coupling member having a frame portion for securing a plurality of frame members thereto and a steering portion for coupling a steering assembly thereto, the frame portion including a first channel, a second channel, a first cylindrical member, and a second cylindrical member for receiving the plurality of frame members, the first channel including an upper portion having a first upper-most surface and a lower portion, and the second channel including an upper portion having a second upper-most surface and a lower portion, and
  - the steering portion including a first web and a second web for receiving a steering post of the steering assembly, the first web including an upper-most surface directly coupled to the first upper-most surface of the first channel and the second upper-most surface of the second channel such that the upper-most surfaces of the first web, the first channel, and the second channel define a continuous outer surface of an upper portion of the coupling member, and the second web extending between the lower portion of the first channel and the lower portion of the second channel.
13. The connector of claim 12, wherein a first axis of the first channel is intersected by a first axis of the first cylindrical member and a second axis of the second channel is intersected by a second axis of the second cylindrical member.
14. The connector of claim 12 or 13, wherein the steering post is operatively coupled to a back face of the first web and a back face of the second web between 0 and 15 degrees.
15. The connector of any one of claims 12 to 14, further comprising a tab for mounting a fuel tank to the connector.
16. The connector of any one of claims 12 to 15, wherein the first web is vertically aligned with rearwards ends of the first and the second cylindrical members.

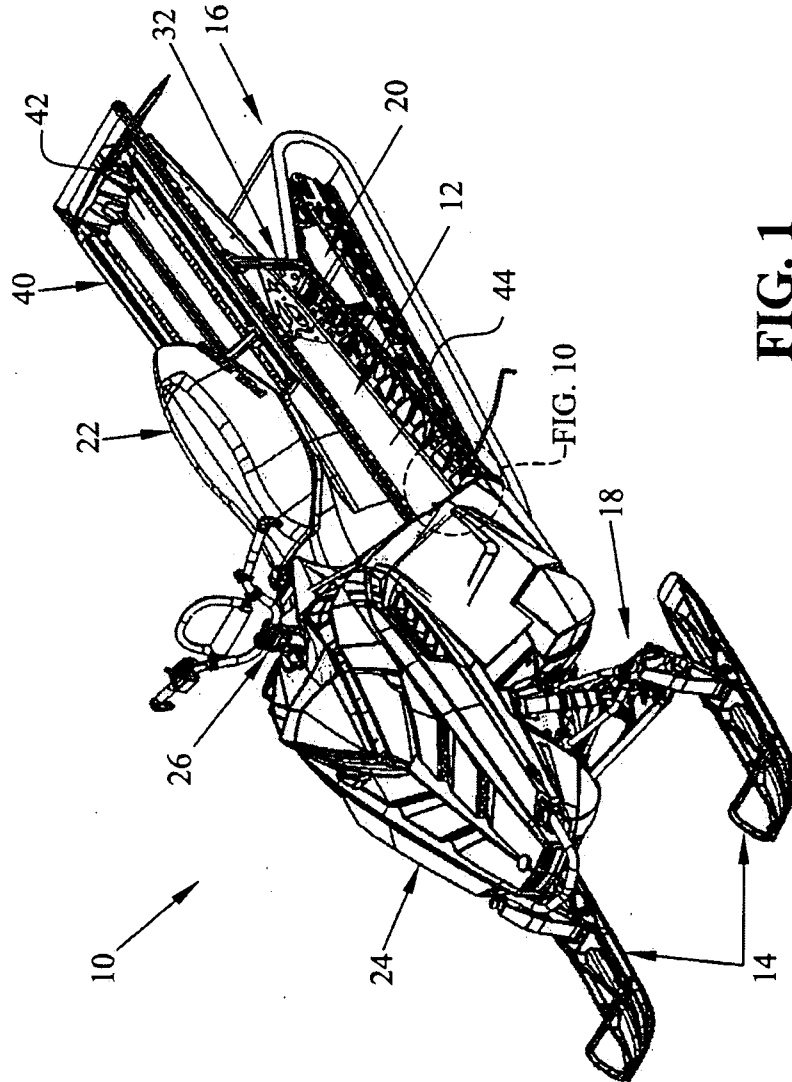

FIG. 1

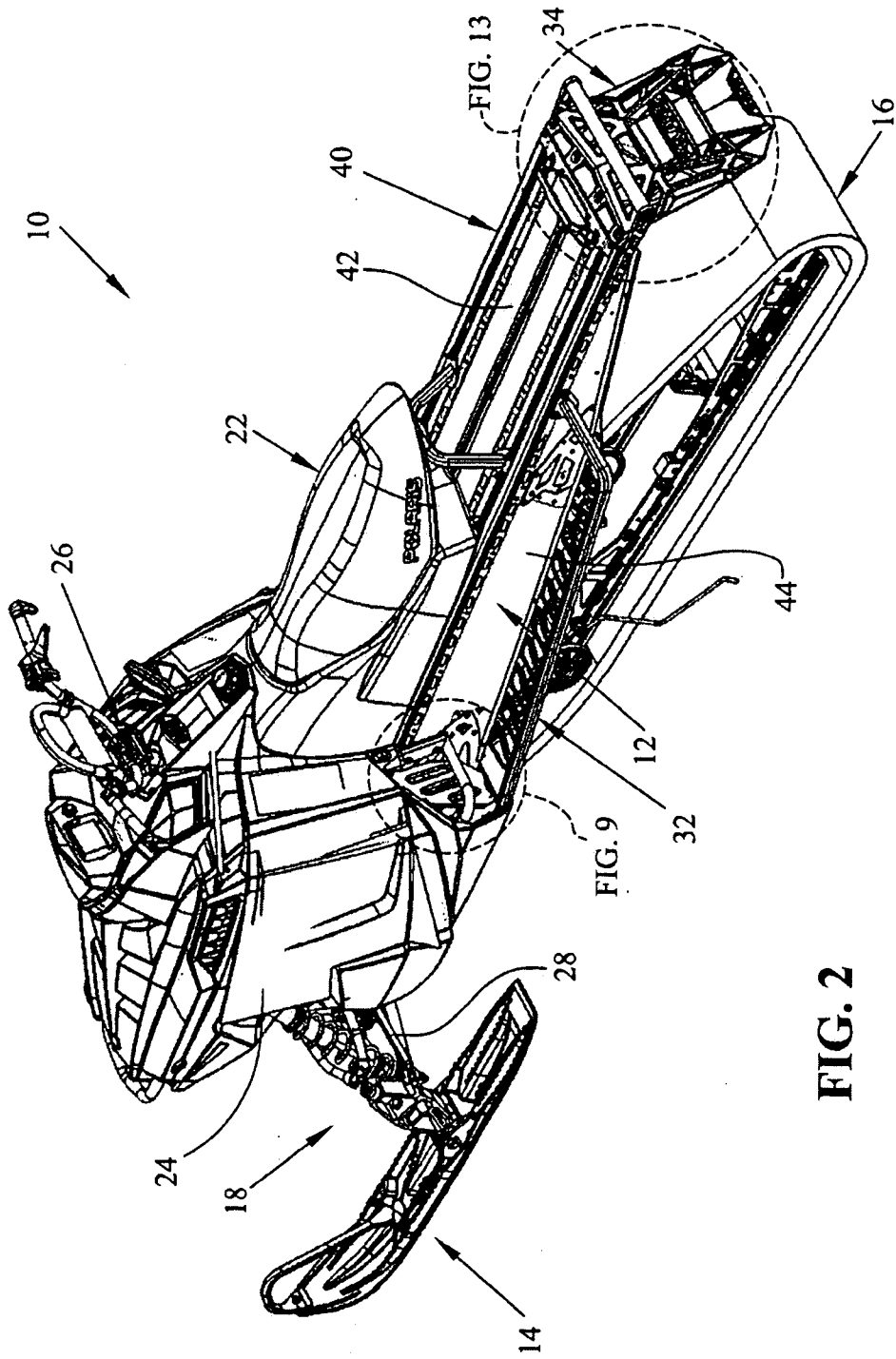

FIG. 2

3/22

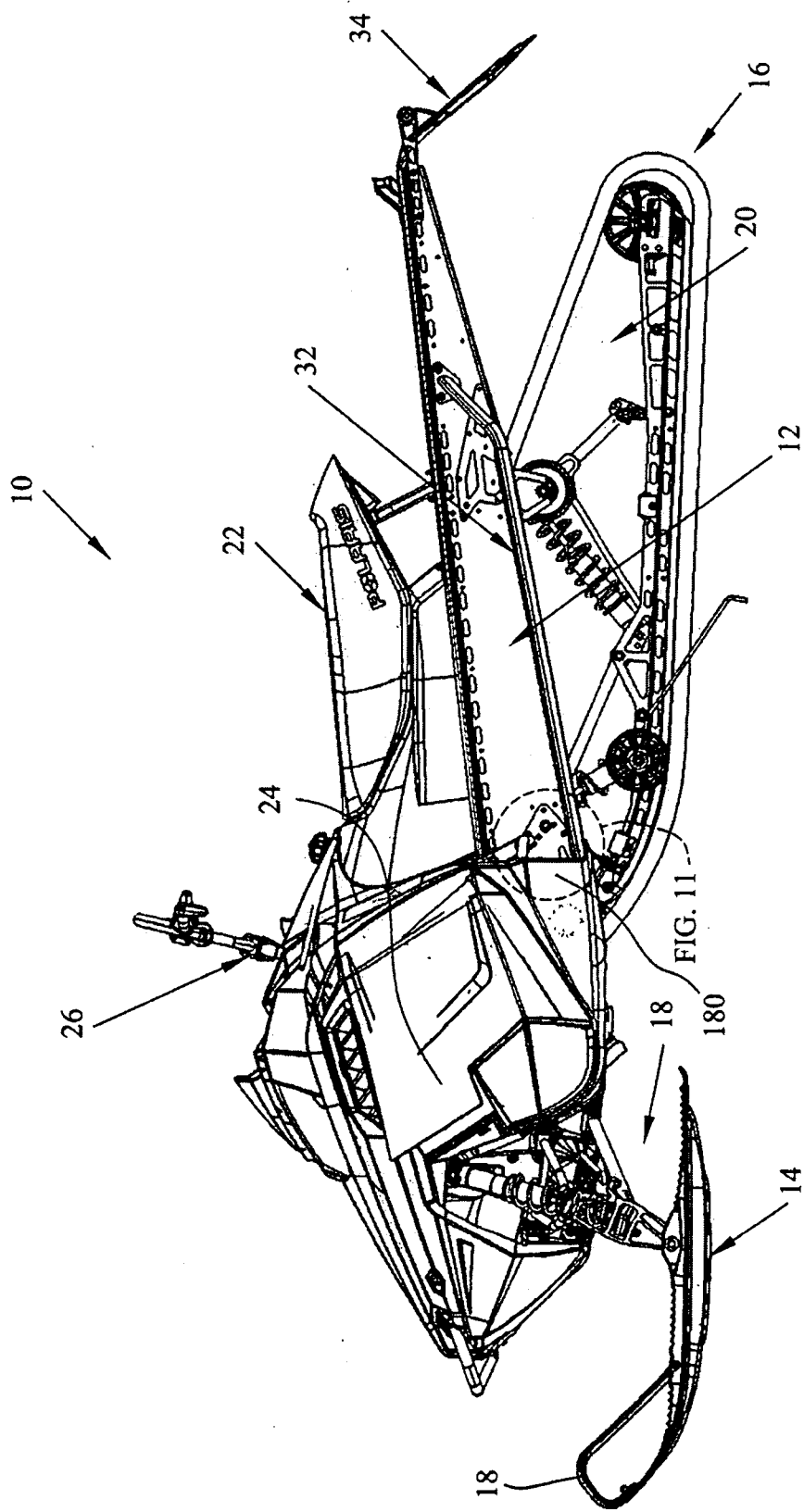

FIG. 3

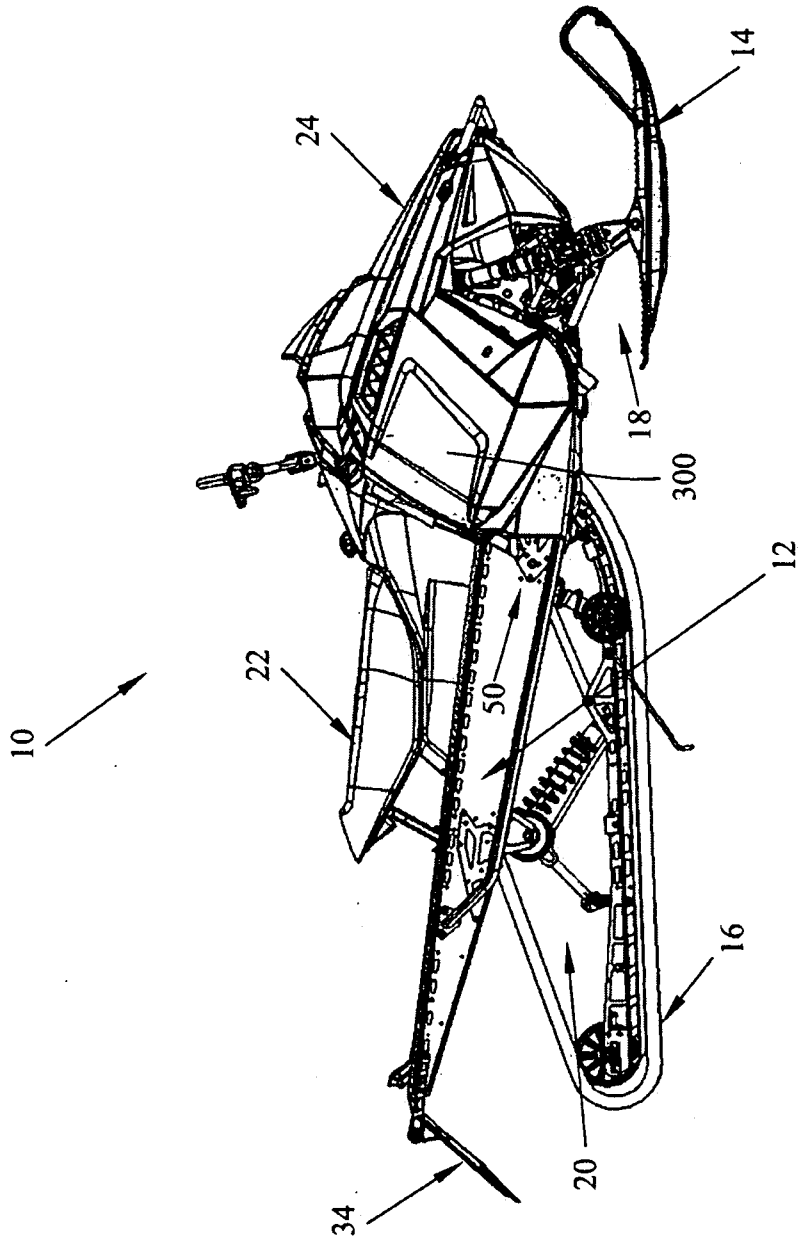
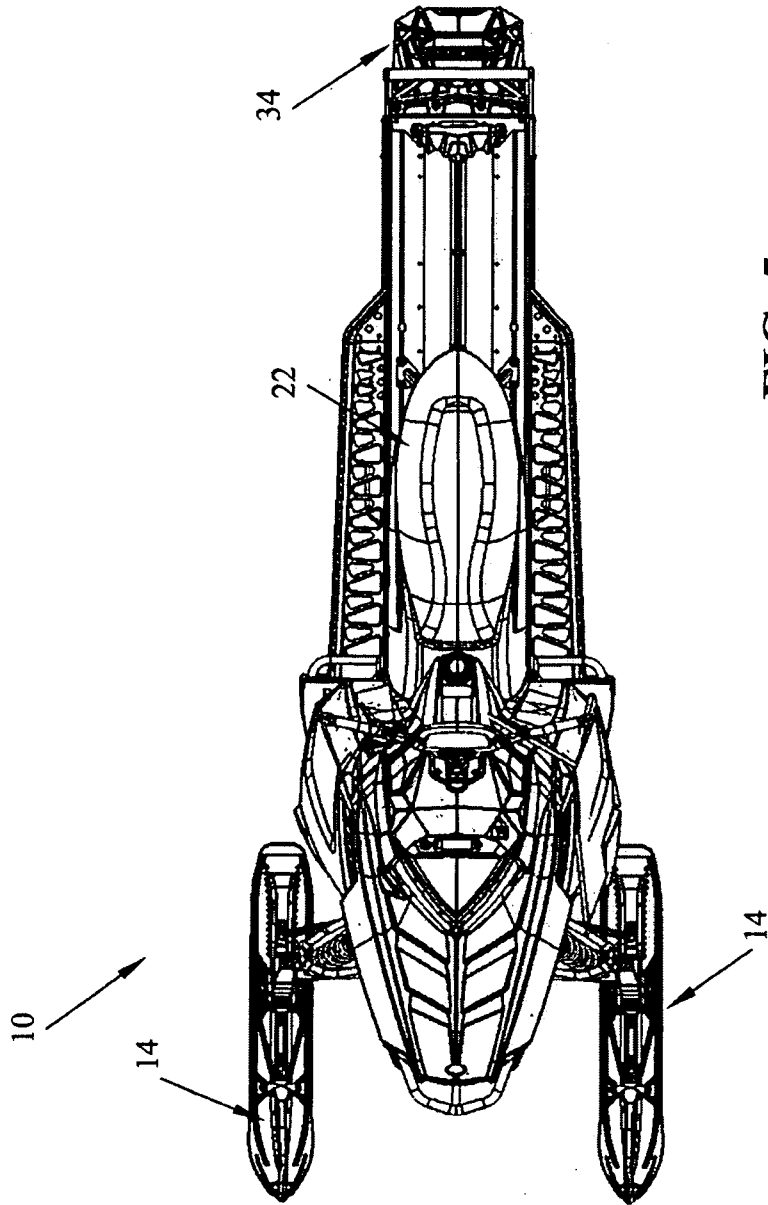
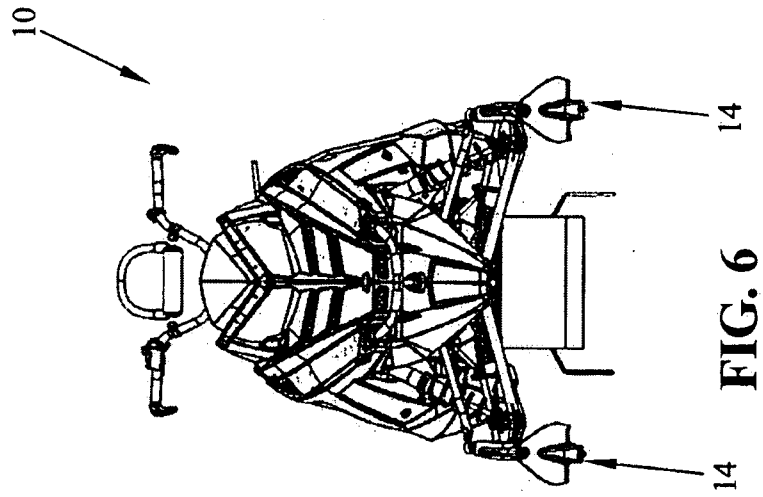
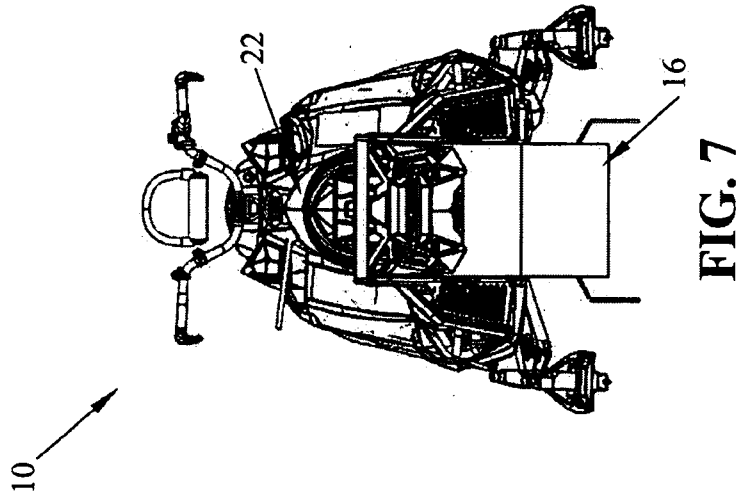

FIG. 4



**FIG. 5**



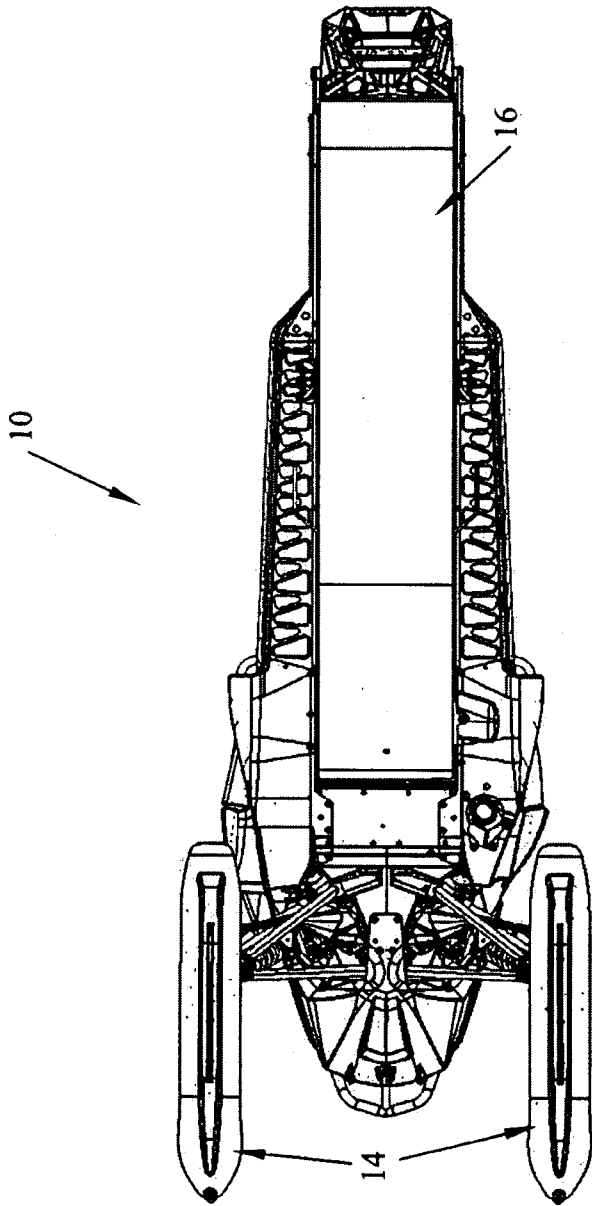

FIG. 8

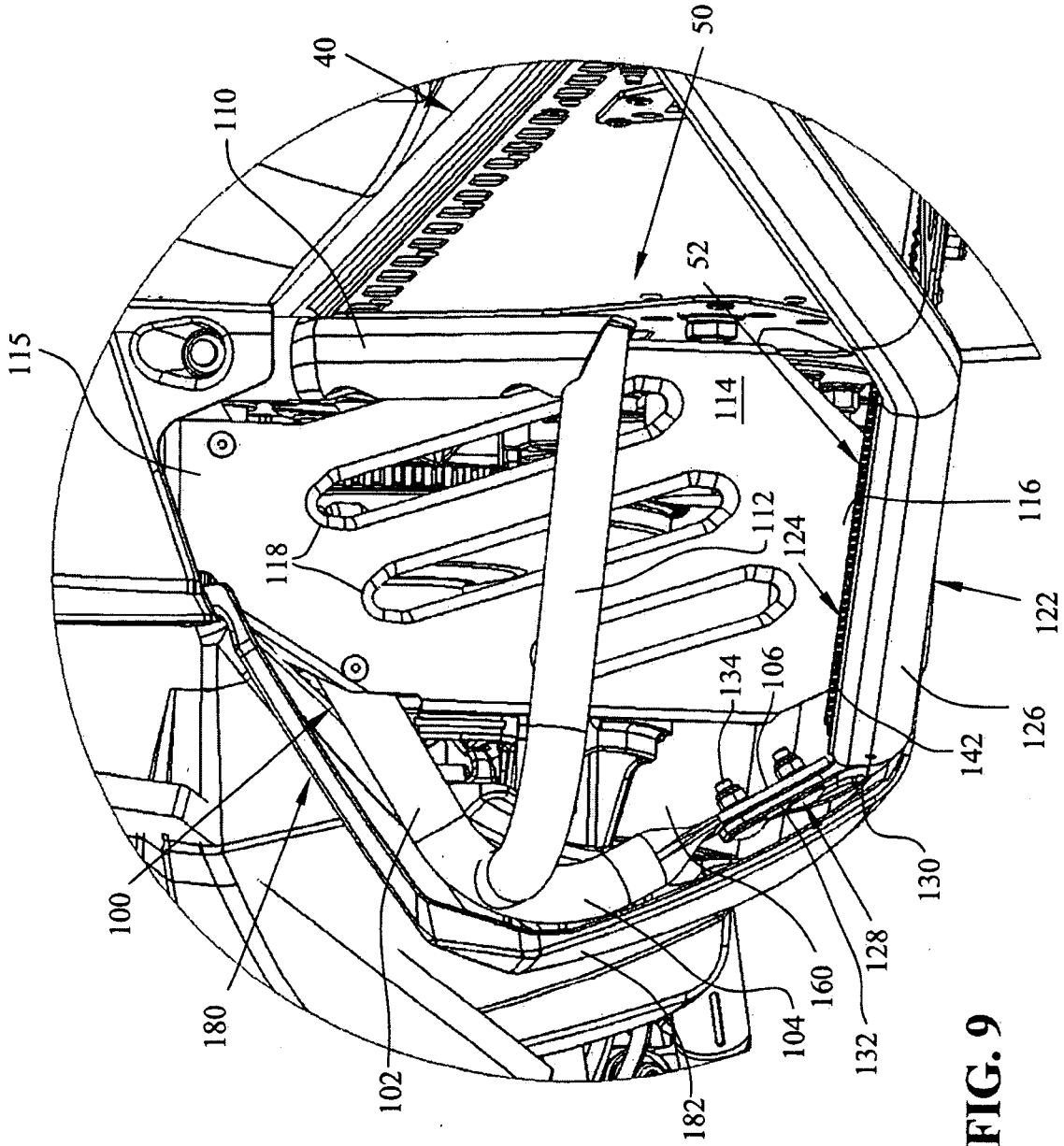
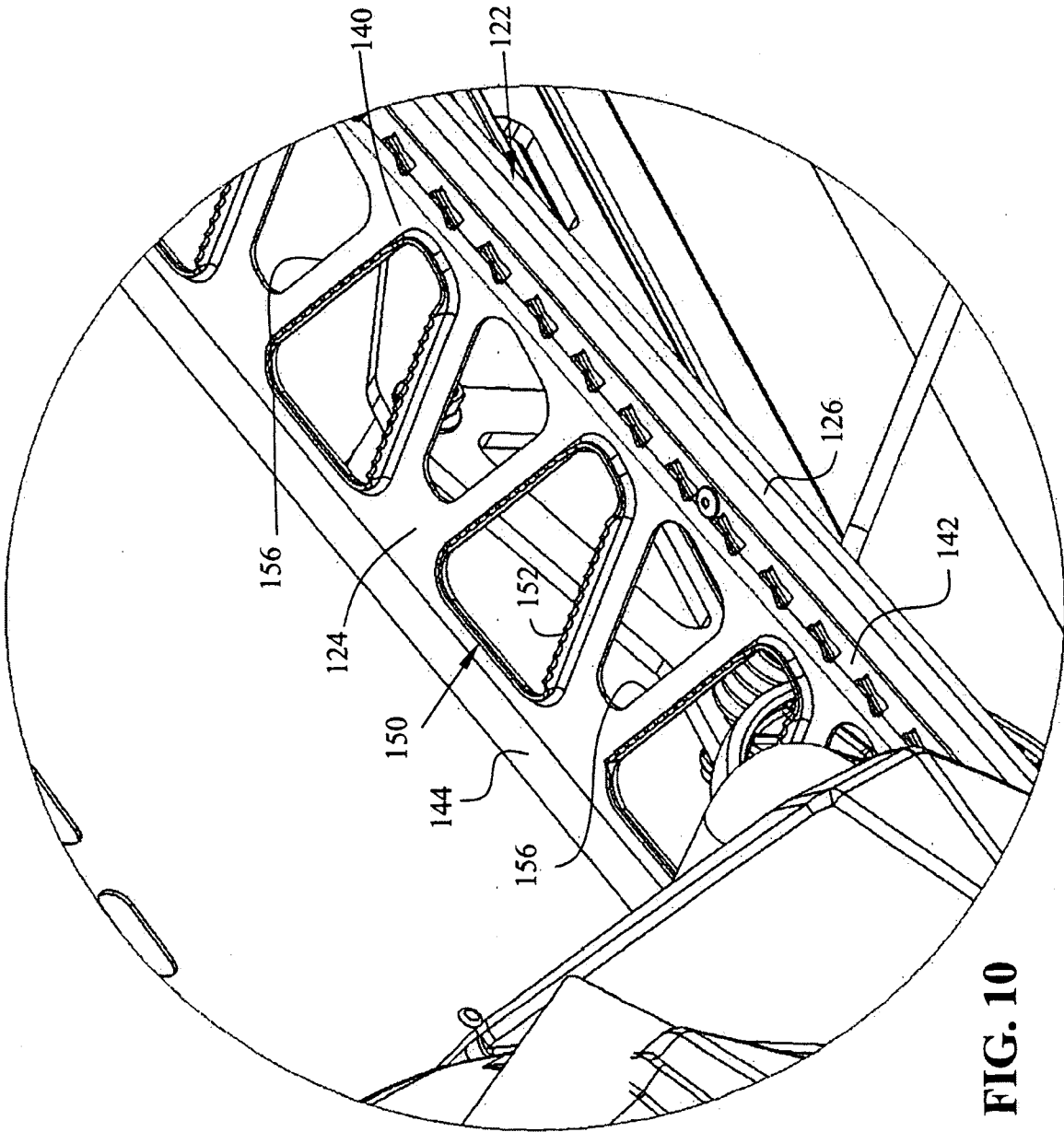
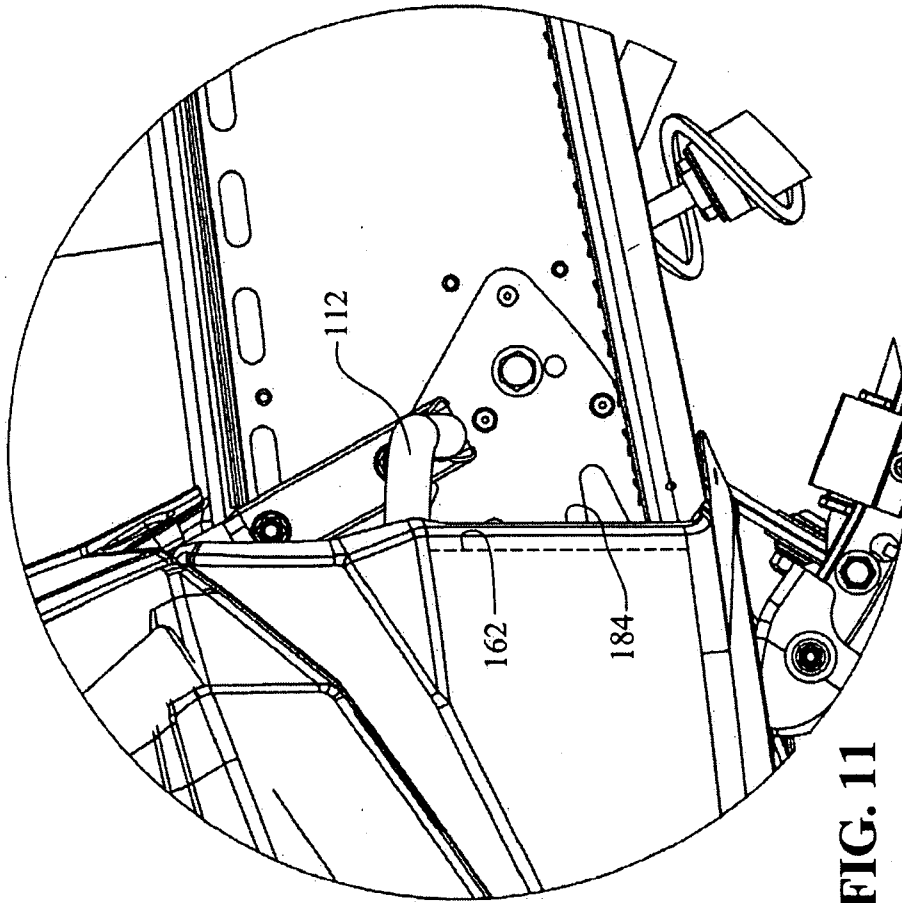

FIG. 9

9/22



**FIG. 10**



**FIG. 11**

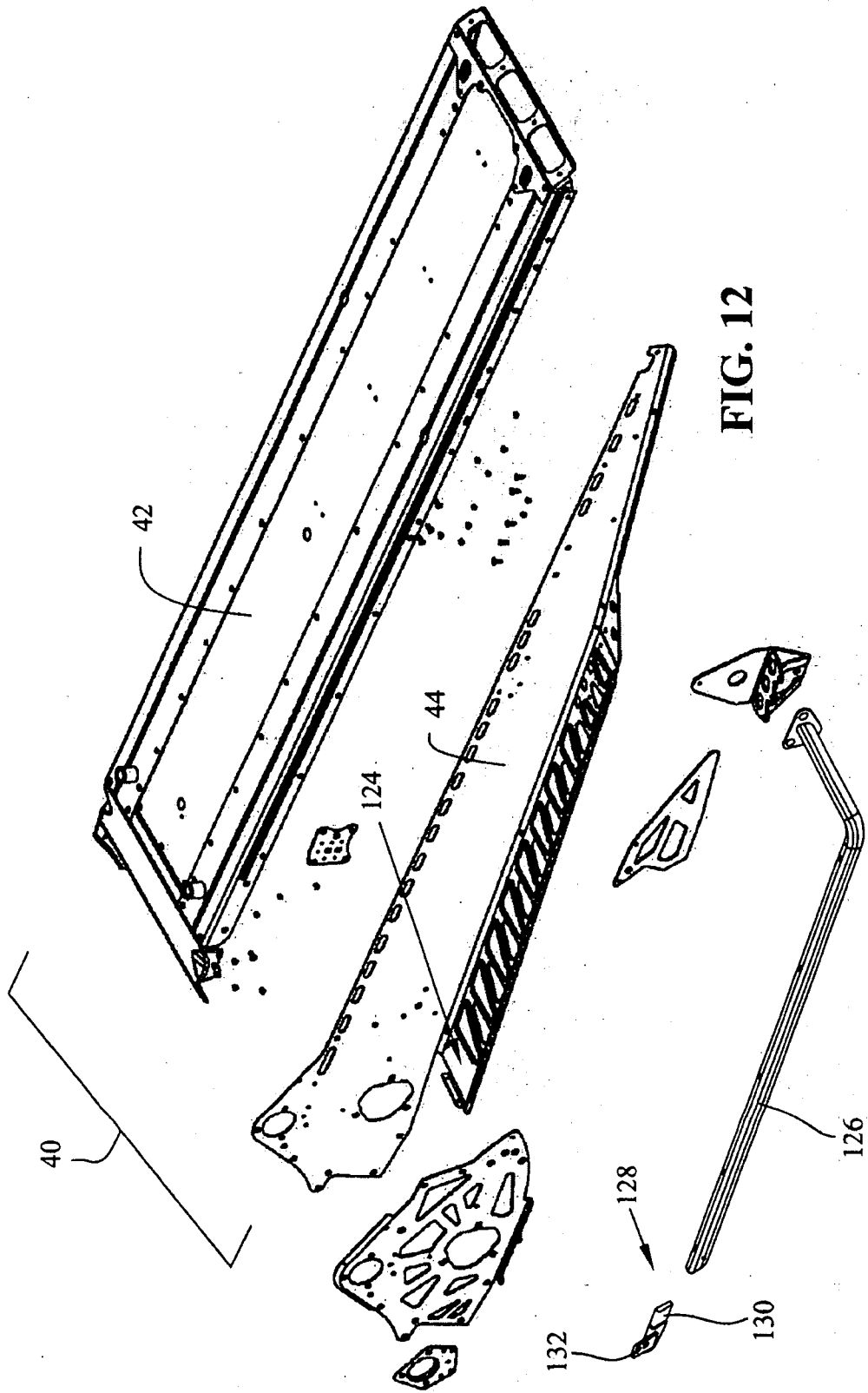

FIG. 12

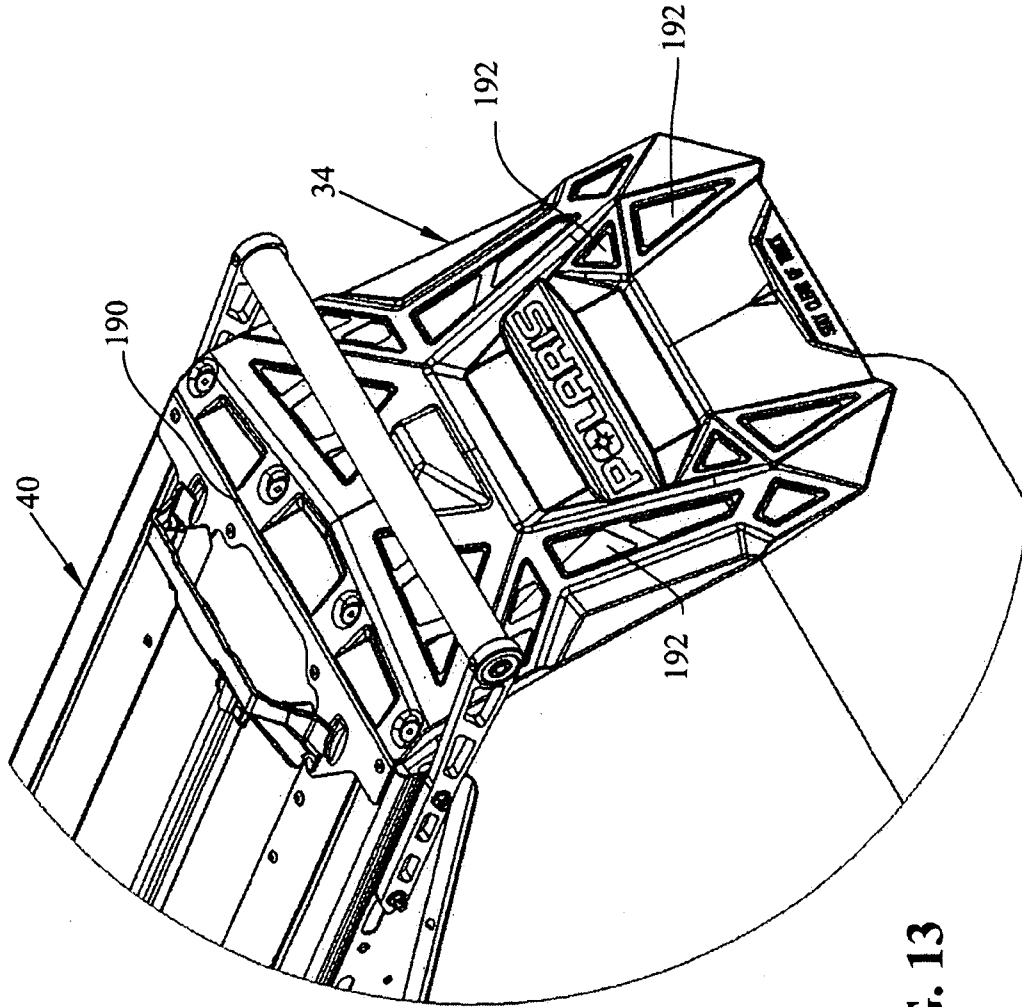

FIG. 13

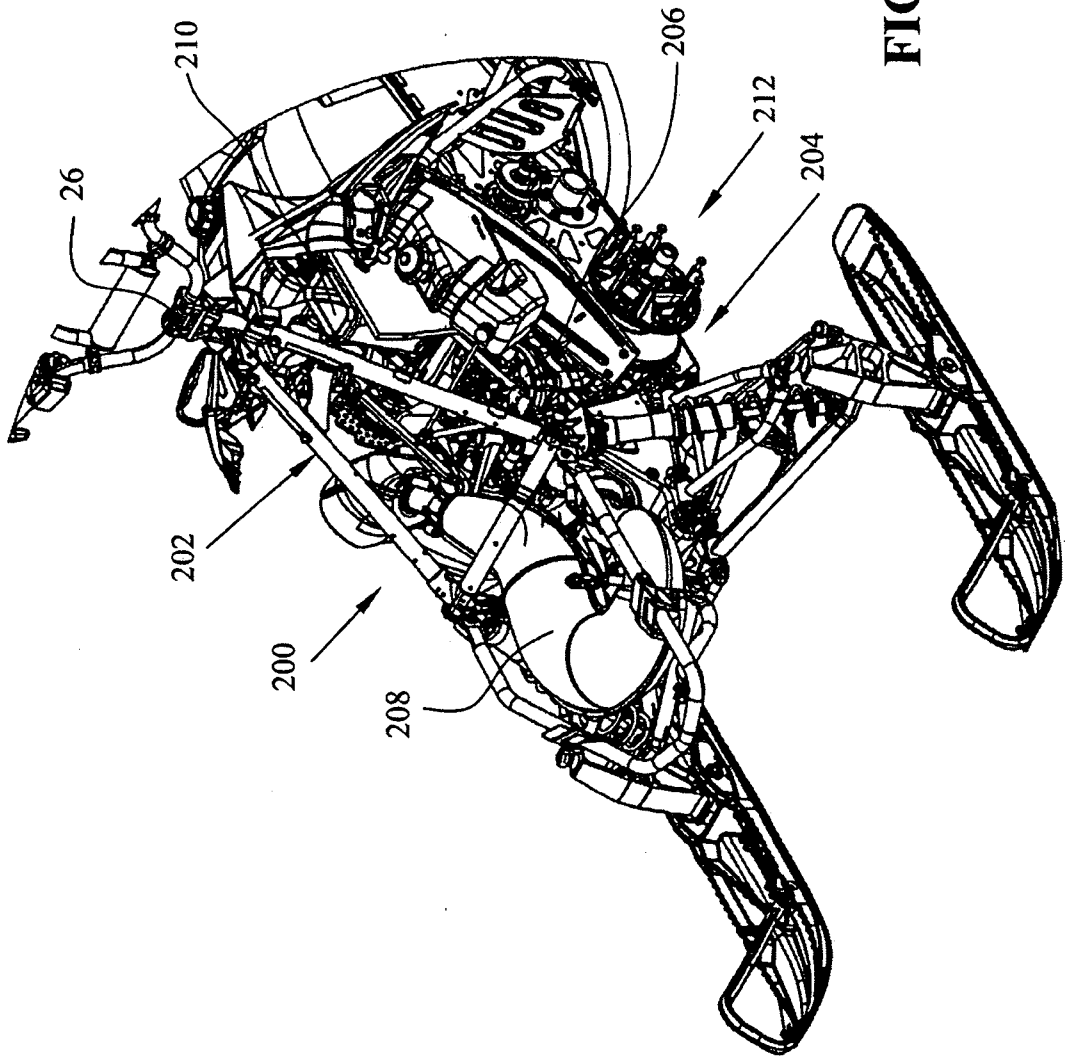

FIG. 14

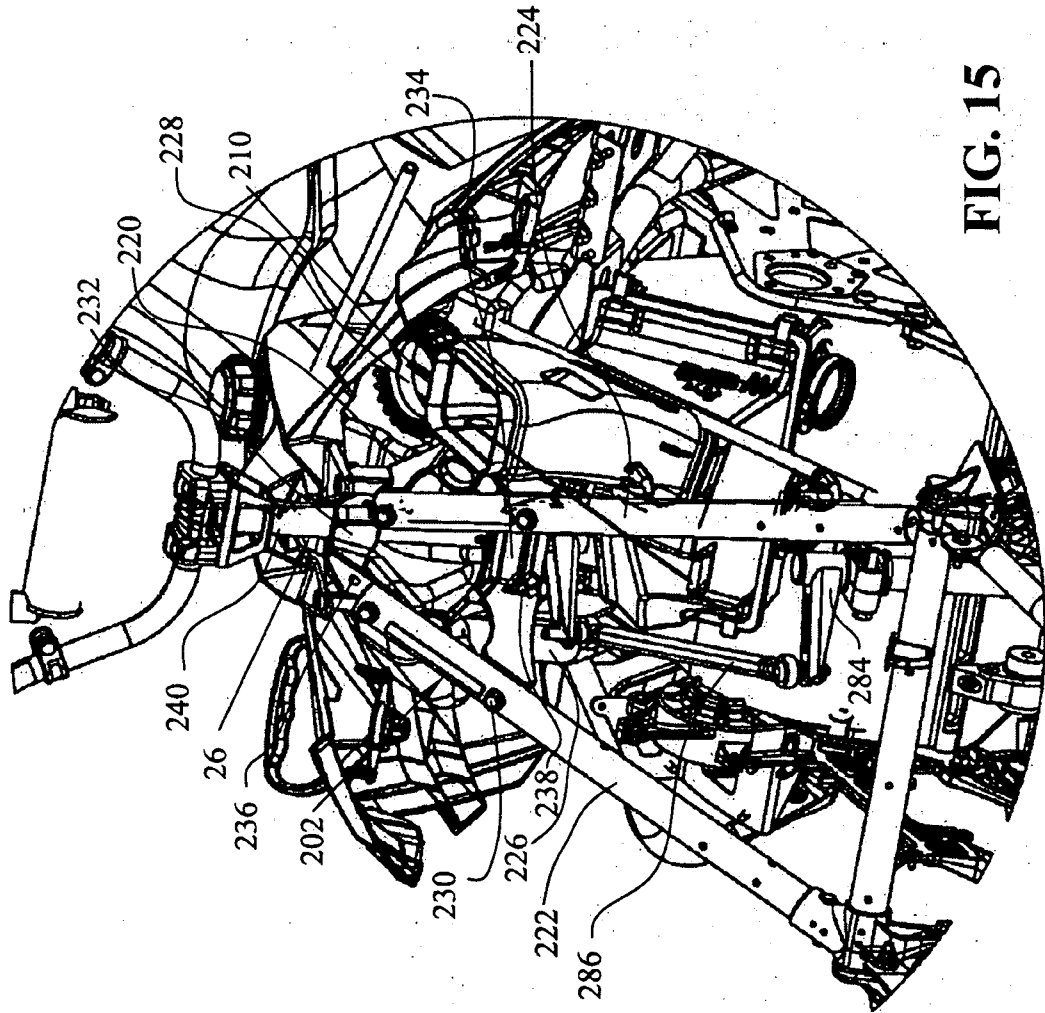

FIG. 15

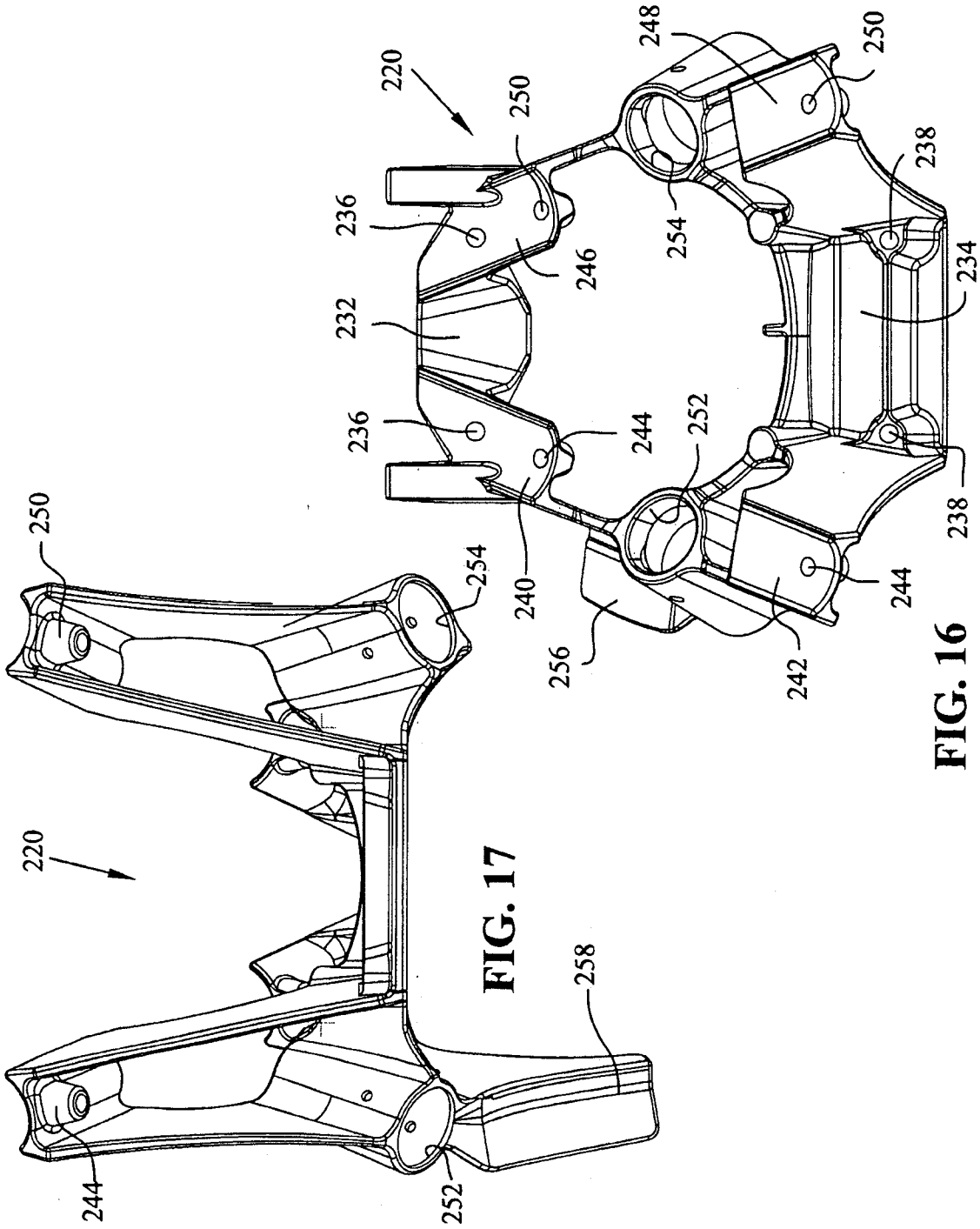
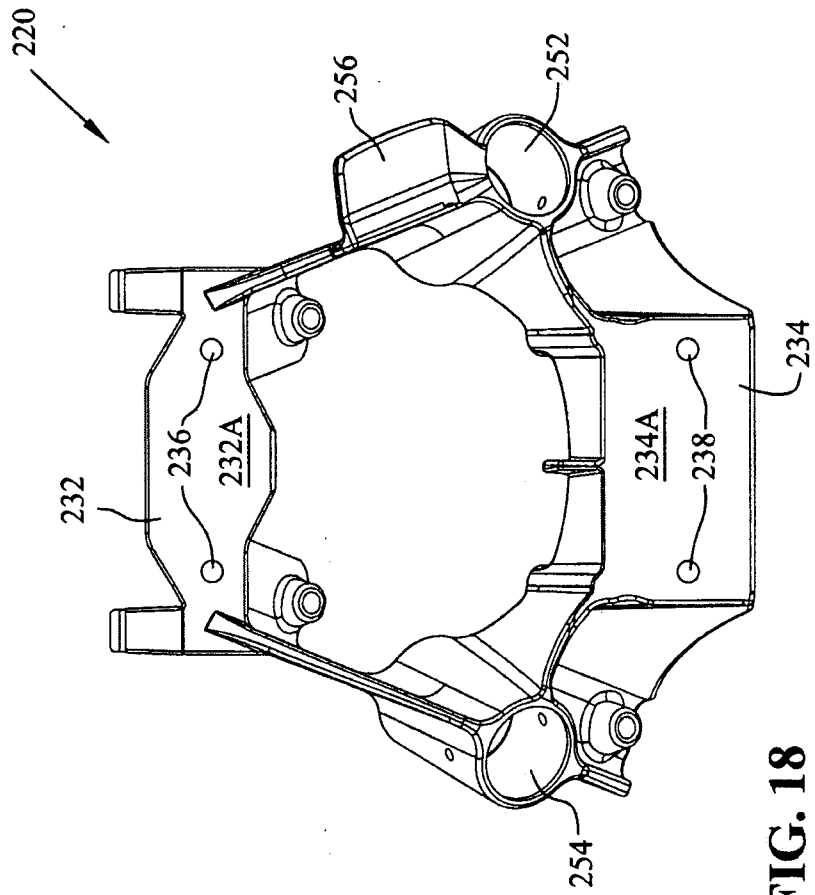

FIG. 16

FIG. 17



**FIG. 18**

FIG. 19

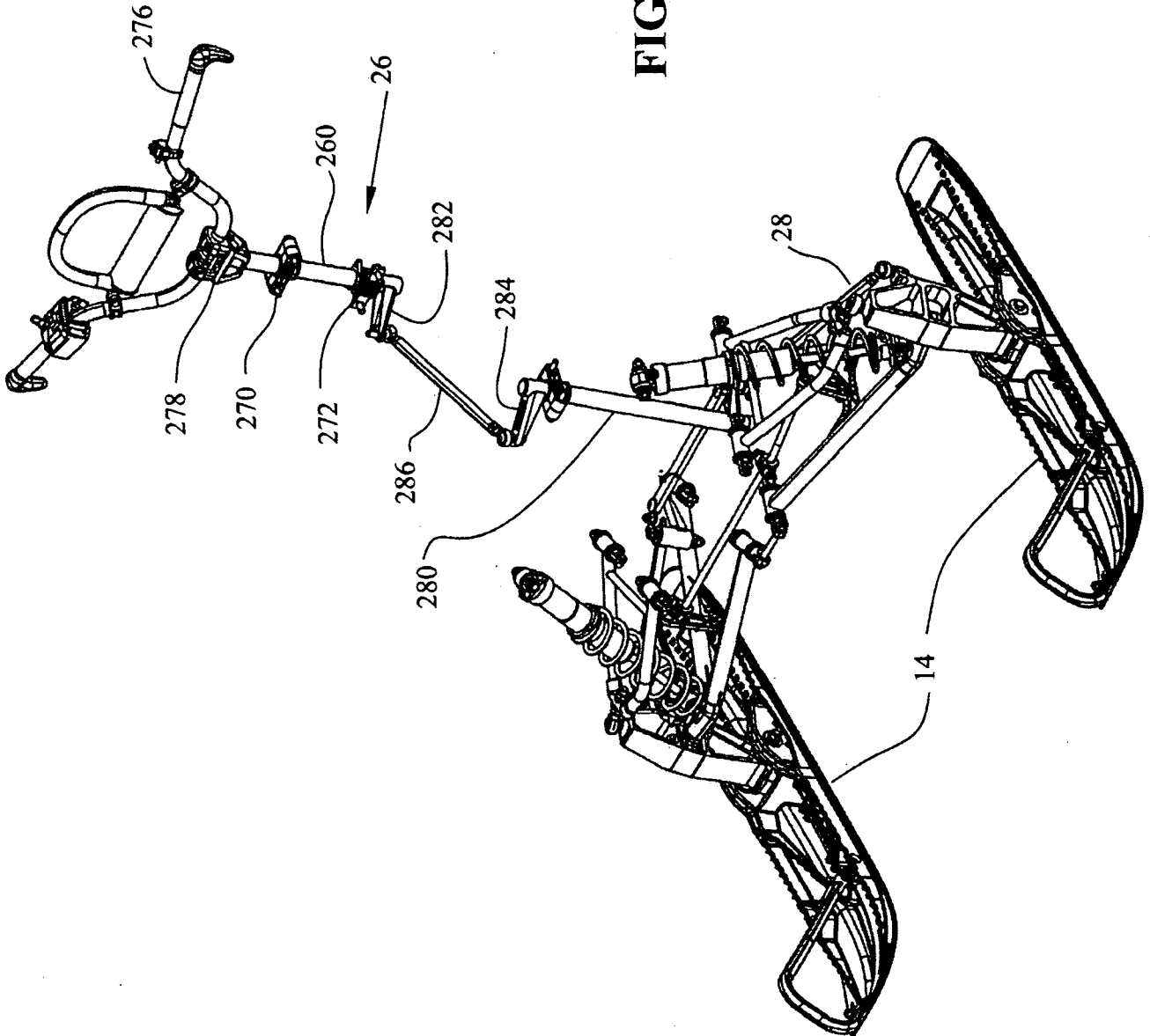

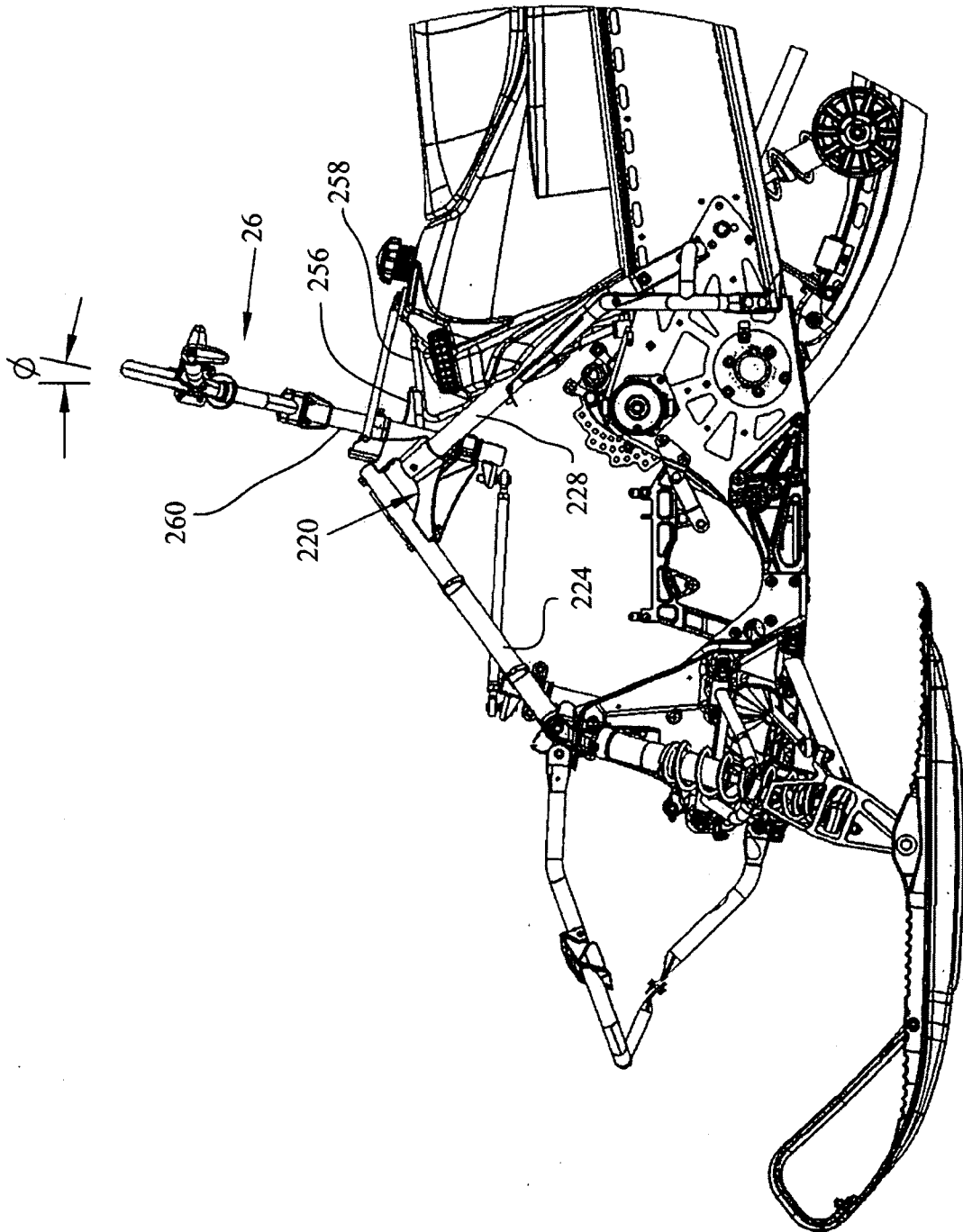

FIG. 20

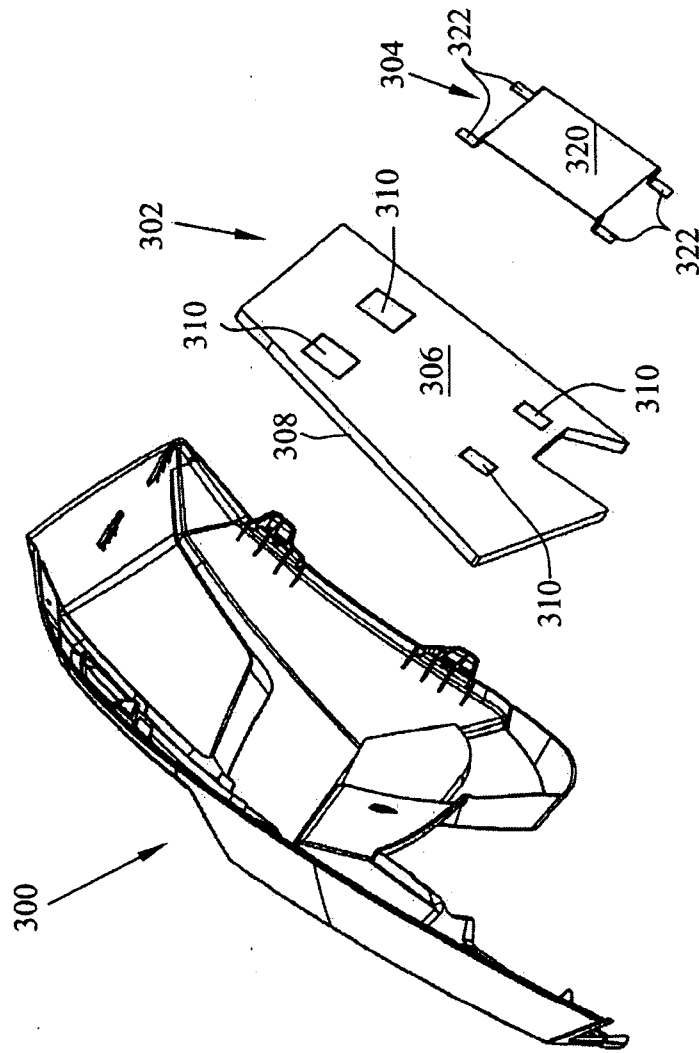
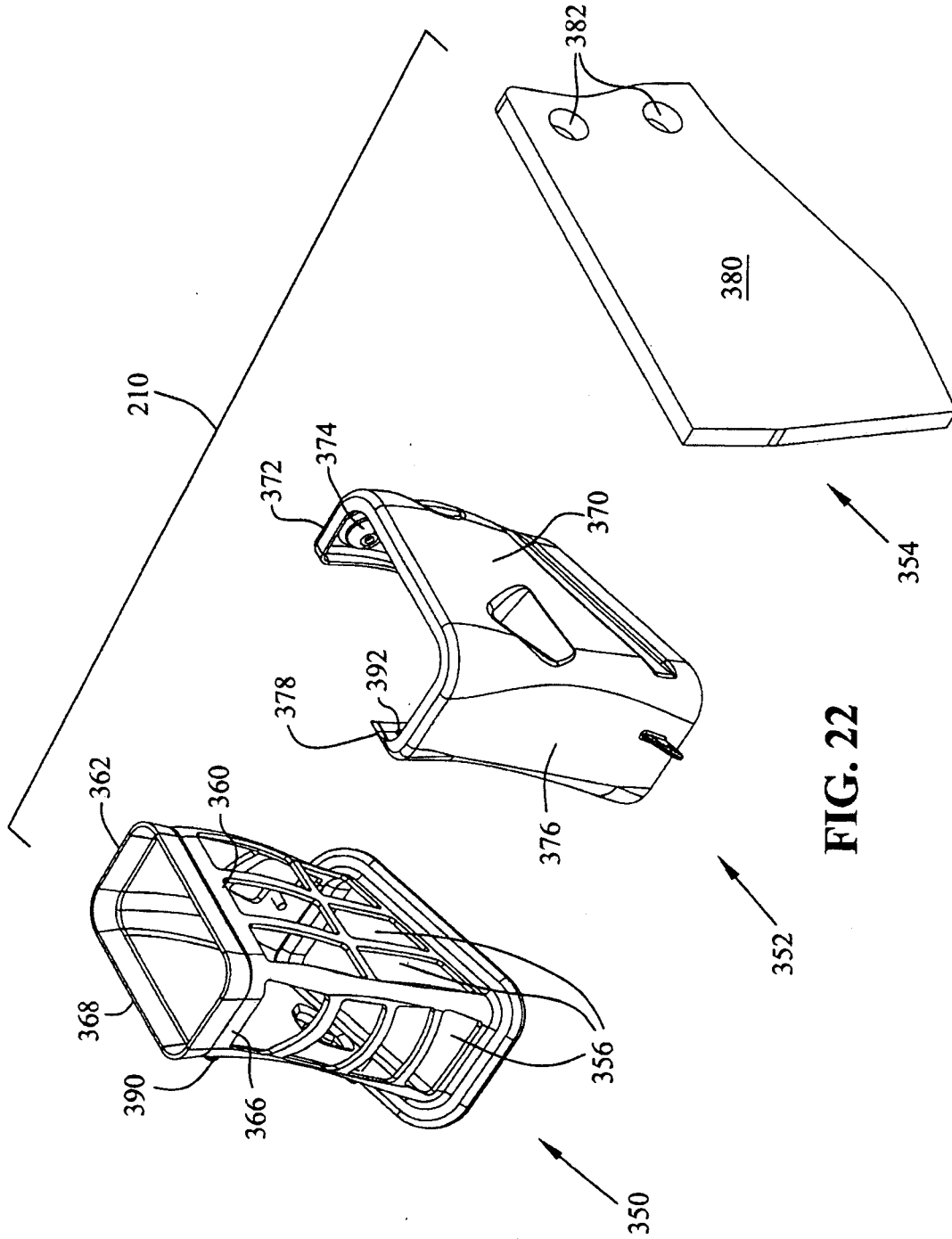

FIG. 21



**FIG. 22**

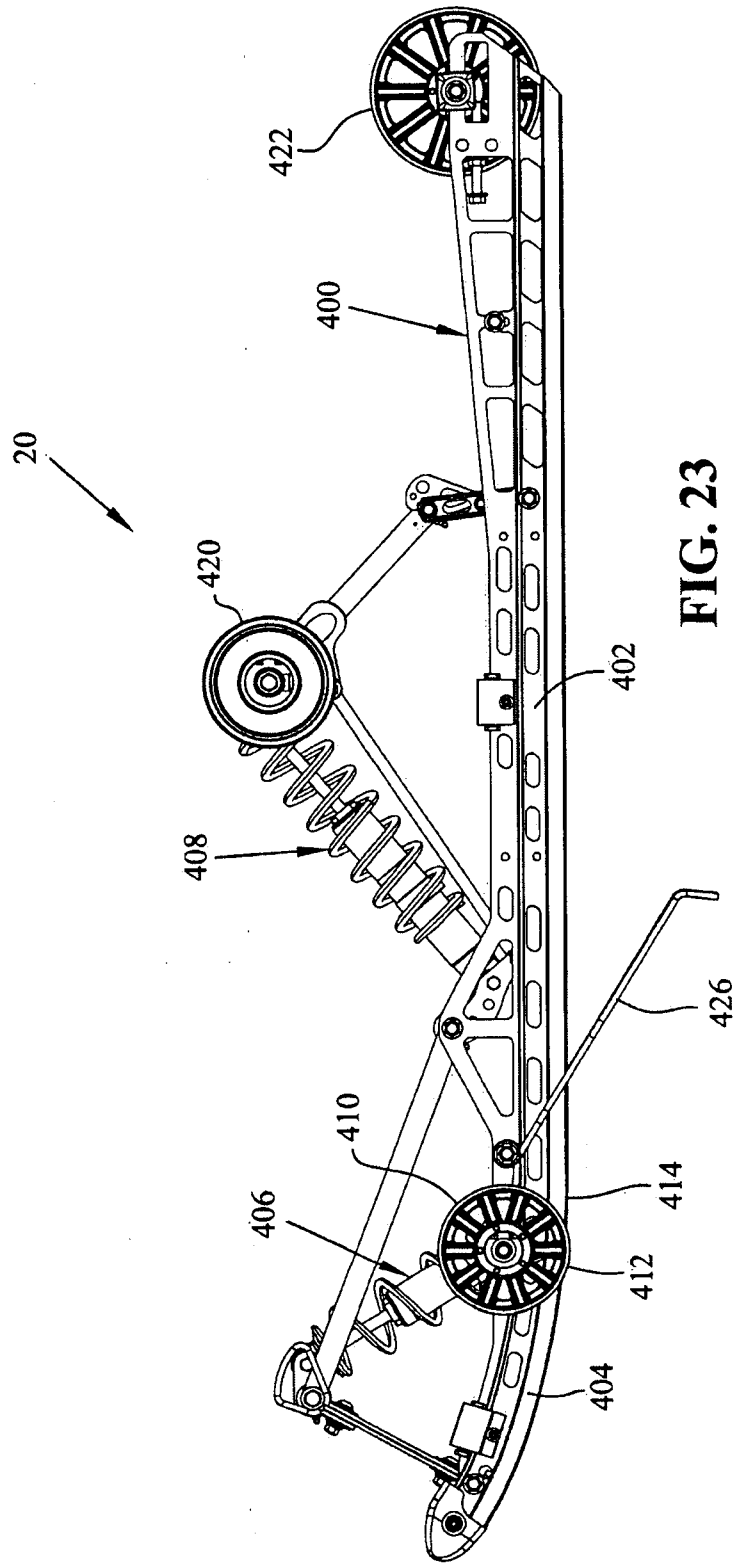

FIG. 23

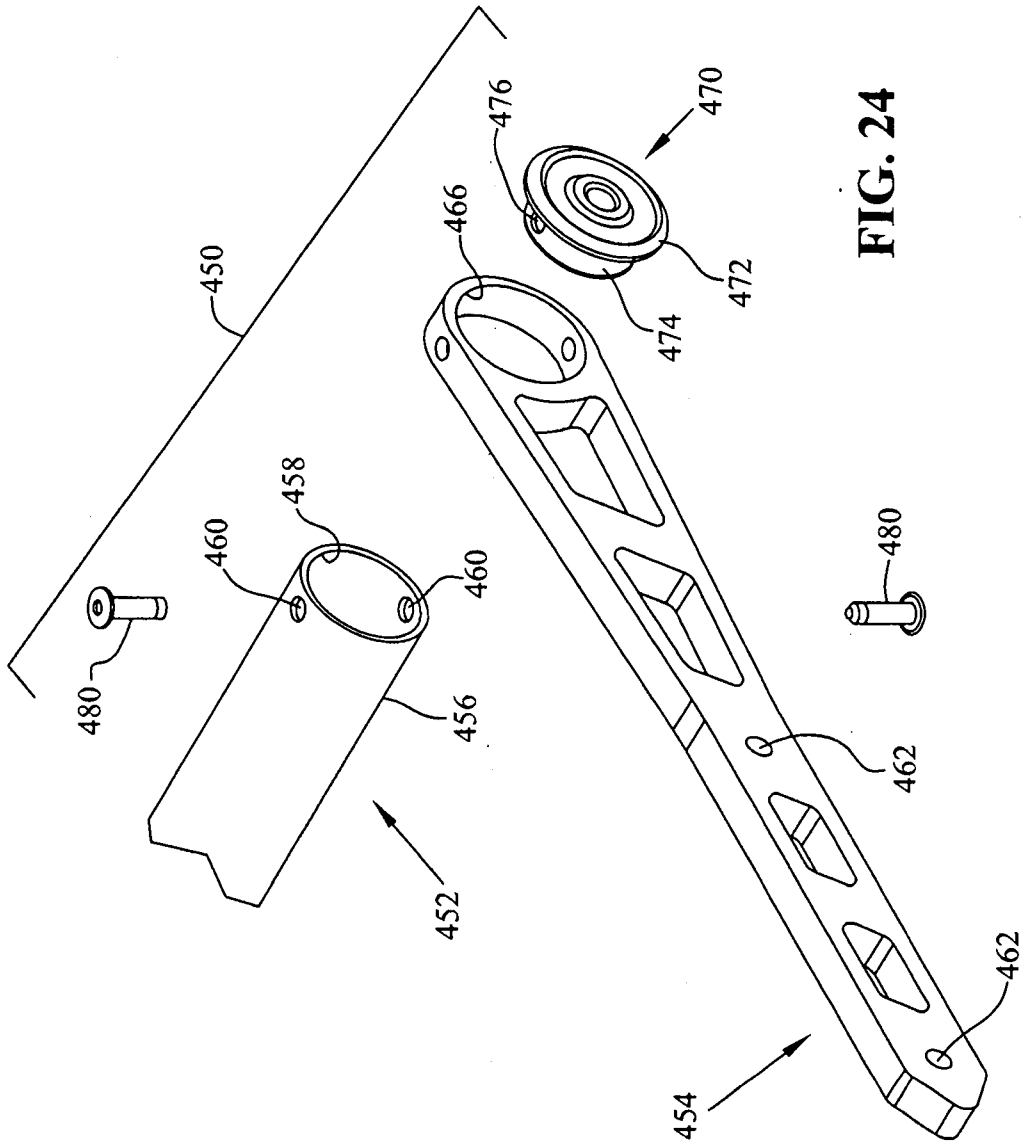

FIG. 24

