

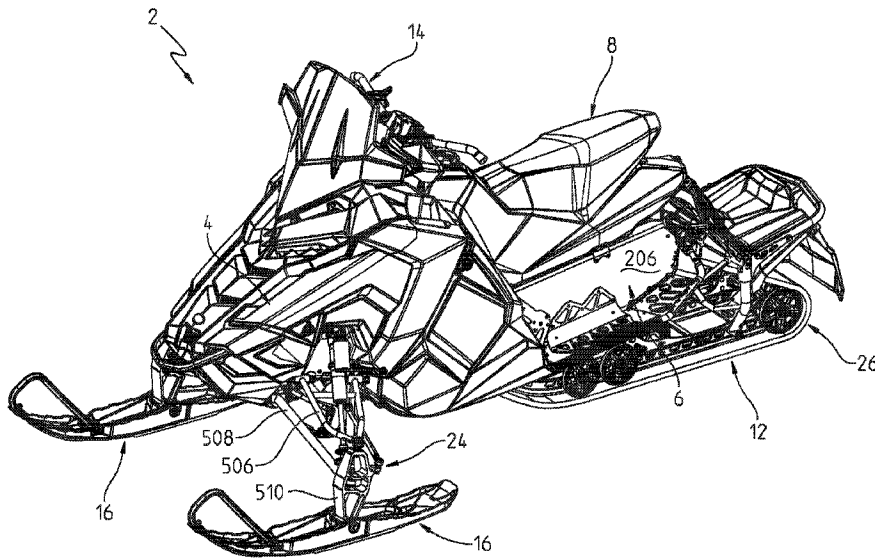

(22) Date de dépôt/Filing Date: 2015/01/08
 (41) Mise à la disp. pub./Open to Public Insp.: 2015/07/16
 (45) Date de délivrance/Issue Date: 2023/08/08
 (62) Demande originale/Original Application: 2 935 113
 (30) Priorités/Priorities: 2014/01/10 (US14/152,596);
 2014/01/29 (US61/933,237)

(51) Cl.Int./Int.Cl. *B62M 27/02* (2006.01),
B62D 55/07 (2006.01)
 (72) Inventeurs/Inventors:
 VISTAD, JAN R., US;
 MERTENS, DUSTIN A., US;
 MILLS, ANDREW J., US;
 HEDLUND, MICHAEL A., US;
 EATON, JEFFREY A., US;
 HEDLUND, DARREN J., US
 (73) Propriétaire/Owner:
 POLARIS INDUSTRIES INC., US
 (74) Agent: MARKS & CLERK

(54) Titre : MOTONEIGE
 (54) Title: SNOWMOBILE



(57) **Abrégé/Abstract:**

A snowmobile comprises: a chassis, comprising a tunnel, an engine cradle and a bulkhead; an engine supported by the chassis; a drive belt supported by the chassis; and a drive assembly for driving the drive belt, comprising a jack shaft driven by the engine and a drive shaft for driving the belt. A portion of the chassis includes an integrated casing for receiving the jack shaft and drive shaft therein, and for enclosing sprockets attached to the jack shaft and drive shaft.

ABSTRACT

A snowmobile comprises: a chassis, comprising a tunnel, an engine cradle and a bulkhead; an engine supported by the chassis; a drive belt supported by the chassis; and a drive assembly for driving the drive belt, comprising a jack shaft driven by the engine and a drive shaft for driving the belt. A portion of the chassis includes an integrated casing for receiving the jack shaft and drive shaft therein, and for enclosing sprockets attached to the jack shaft and drive shaft.

SNOWMOBILE

BACKGROUND AND SUMMARY

[0001] The present disclosure relates to snowmobiles, and more particularly, the present disclosure relates generally to the frame assembly, suspension assembly,
5 cooling system and air intake system for snowmobiles.

[0002] One of the performance characteristics of all vehicles, including snowmobiles, includes the noise, vibration and harshness, the so-called NVH of the vehicle. This includes the comfort of the ride, and depends on a variety of systems and components, including the snowmobile suspension. Typically, a snowmobile
10 suspension includes two systems, a front suspension system for a pair of skis and a rear suspension system for the track.

[0003] The front suspension of the snowmobile is coupled to the chassis of the snowmobile and to steerable skis. The front suspension may include one or more suspension arms on each side of the snowmobile.

[0004] The rear suspension of a snowmobile supports an endless track driven by the snowmobile engine to propel the machine. The track is supported beneath a vehicle chassis by a suspension that is designed to provide a comfortable ride and to help absorb the shock of the snowmobile crossing uneven terrain. Most modern snowmobiles use a slide rail suspension which incorporates a pair of slide rails along
15 with several idler wheels to support the track in its configuration. The slide rails are typically suspended beneath the chassis by a pair of suspension arms, with each arm being attached at its upper end to the chassis of the snowmobile, and at its lower end to the slide rails.
20

[0005] Noise of the vehicle is also a factor. Intake noise has been a concern for snowmobile designs, and includes the intake noise, that is, the noise from the engine caused by the rush of air flow into the combustion chambers of the engine. Some attempts to control the intake noise are done through air intake silencers. Recent
25

designs have become larger and more complicated and it has become difficult to further reduce intake noise due to a lack of volume available in the engine compartment.

5 **[0006]** Continued development of snowmobile platforms and the high performance 2-stroke engines that power them have driven platform architecture towards smaller, lighter and more compact integrated systems. As manufacturers push for lighter and smaller vehicles, the engine area space in the snowmobile engine compartment becomes increasingly limited, requiring efficient utilization of non-traditional packaging limitations. One of the areas requiring re-design is the highly tuned and critical 2-stroke exhaust pipe.

10 **[0007]** In one embodiment, a snowmobile comprises a chassis, comprising a front chassis portion and a rear chassis portion; an engine positioned in the front chassis portion and having at least one intake port and at least one exhaust port; a front body portion defined over the front chassis portion and defining an engine compartment; a plenum assembly coupled to the front chassis portion and having at least one intake
15 air vent and at least one air exit opening; and at least one duct coupled to the air exit opening and communicating air to the air intake, the duct being at least partially comprised of a porous material, whereby sound from the air intake is dissipated in the engine compartment.

[0008] In another embodiment, a snowmobile comprises a chassis, comprising a
20 front chassis portion and a rear chassis portion; an engine positioned in the front chassis portion and having at least one intake port and at least one exhaust port; a front body portion defined over the front chassis portion and defining an engine compartment, at least one portion of the front body portion being fixed relative to the front chassis and at least one other portion being movable relative to the front chassis; at least one air
25 vent positioned in the fixed front body portion; and an air intake system coupled to the at least one air vent and communicating air through the front body portion to the engine intake port, at least one portion of the air intake system being at least partially comprised of a porous material, whereby sound from the air intake is dissipated through the porous material and into the engine compartment.

[0009] In another embodiment, a snowmobile comprises a chassis; an engine supported by the chassis; a front suspension coupled to the chassis and to steerable skis; the front suspension comprising at least one suspension arm; and couplings coupling the at least one suspension arm to the chassis, the couplings comprising a
5 movable portion mountable to the chassis in multiple lateral positions, relative to the suspension arm for accommodating wear.

[0010] In yet another embodiment, a snowmobile comprises a chassis including a bulkhead and a tunnel; an engine supported by the chassis; a coupler attached to the chassis having plural connection points for coupling plural frame braces to the tunnel.

10 **[0011]** In a further embodiment, a snowmobile comprises a chassis, having a tunnel, an engine cradle and a bulkhead; an engine supported by the chassis; a drive belt supported by the chassis; a drive assembly for driving the drive belt, comprising a jack shaft driven by the engine and a drive shaft for driving the belt; a portion of the chassis including an integrated casing for receiving the jack shaft and drive shaft
15 therein, and for enclosing sprockets attached to the jack shaft and drive shaft.

[0012] In yet another embodiment, a snowmobile comprises a chassis; a water cooled engine supported by the chassis; and a cooler, the cooler comprising: a top wall, a lower wall, internal ribs connecting the top and lower wall and defining channels, an opening in one of the channels, an insert having an inlet port, an outlet port and a
20 separating rib, the insert being positioned in the opening with the separating rib separating the one channel into two divided channel portions, the inlet port communicating with a first divided channel portion and the outlet port communicating with a second divided channel portion, and side walls positioned between the top and lower wall and enclosing the channels.

25 **[0013]** In yet another embodiment, an exhaust pipe, comprises a diffuser, an expansion chamber, a rear cone, and a stinger tube extending into the rear cone, wherein the stinger tube and rear cone are curved, with centerlines of the stinger tube and rear cone being concentric.

[0013a] In yet another embodiment, a snowmobile comprises: a chassis, comprising a tunnel, an engine cradle and a bulkhead; an engine supported by the chassis; a drive belt supported by the chassis; and a drive assembly for driving the drive belt, the drive assembly comprising a jack shaft driven by the engine and a drive shaft
5 for driving the drive belt, wherein a portion of the chassis includes an integrated casing for receiving the jack shaft and the drive shaft therein, and for enclosing sprockets attached to the jack shaft and the drive shaft, and wherein the engine cradle comprises a frame portion having a continuous surface with the integrated casing and including a mounting bracket configured to directly couple to the bulkhead.

10 **[0013b]** In yet another embodiment, a snowmobile comprises: a chassis, comprising a tunnel, an engine cradle and a bulkhead; an engine supported by the chassis; a drive belt supported by the chassis; and a drive assembly for driving the drive belt, the drive assembly comprising a jack shaft driven by the engine and a drive shaft
15 for driving the drive belt, wherein a portion of the chassis includes an integrated casing for receiving the jack shaft and the drive shaft therein, and for enclosing sprockets attached to the jack shaft and the drive shaft, and wherein the engine cradle comprises a forwardly extending leg portion that is integrally formed and having a continuous surface with the integrated casing.

[0014] An illustrative embodiment will now be described by way of reference to the drawing figures.

BRIEF DESCRIPTION OF THE DRAWINGS

[0015] FIG. 1 shows a left front perspective view of a snowmobile according to
5 the present embodiment;

[0016] FIG. 2 is a right rear perspective view of the snowmobile of FIG. 1;

[0017] FIG. 3 is a left side view of the snowmobile of FIG. 1;

[0018] FIG. 4 is a right side view of the snowmobile of FIG. 1;

[0019] FIG. 5 is a top view of the snowmobile of FIG. 1;

10 **[0020]** FIG. 6 is a front view of the snowmobile of FIG. 1;

[0021] FIG. 7 is a rear view of the snowmobile of FIG. 1;

[0022] FIG. 8 is a rear fragmented view of the operator's area showing a rear side of the air intake system;

[0023] FIG. 9 is a left front perspective view of the air intake system shown
15 removed from the snowmobile;

[0024] FIG. 10 is left rear perspective view of the air intake system shown removed from the snowmobile;

[0025] FIG. 11 is left front perspective view of the air intake system shown in an exploded manner;

20 **[0026]** FIG. 12 shows a perspective view of the ducts of the air intake system;

[0027] FIG. 13A shows an exploded view of one of the ducts shown in FIG. 12;

[0028] FIG. 13B shows an exploded view of the other of the ducts shown in FIG.
12;

- [0029]** FIG. 14 shows a rear view of the air intake system showing the air vents;
- [0030]** FIG. 15 shows a portion of the snowmobile frame;
- [0031]** FIG. 16 shows a view of the snowmobile frame of FIG. 15, showing the frame components exploded away from a frame coupler;
- 5 **[0032]** FIG. 17 shows the frame coupler of FIG. 16 in greater detail;
- [0033]** FIG. 18 shows a rear perspective view of the rear suspension and cooling system;
- [0034]** FIG. 19 shows an underside perspective view of the rear cooler;
- [0035]** FIG. 20 shows a view similar to that of FIG. 18, in an exploded manner;
- 10 **[0036]** FIG. 21 shows a left front perspective view of the cooler;
- [0037]** FIG. 22 shows an exploded view of the cooler of FIG. 21;
- [0038]** FIG. 23 shows a cross-sectional view of the cooler through lines 23-23 of FIG. 21;
- [0039]** FIG. 24 shows a cross-sectional view of the cooler through lines 24-24 of
15 FIG. 21;
- [0040]** FIG. 25 shows a left side view of the front suspension;
- [0041]** FIG. 26 shows a left side view of the upper and lower suspension arms;
- [0042]** FIG. 27 shows an exploded view of the upper suspension arm in an exploded view;
- 20 **[0043]** FIG. 27A is an enlarged view of a portion of the components shown in FIG. 27;

[0044] FIG. 28 shows a cross-sectional view of the coupler through lines 28-28 of FIG. 26;

[0045] FIG. 29 shows a right side perspective view of the transfer case;

[0046] FIG. 30 shows a view similar to that of FIG. 29, with the transfer case cover removed;

[0047] FIG. 31 shows a view similar to that of FIG. 30 with the gears removed;

[0048] Fig. 32 shows a perspective view of an exhaust pipe according to the present disclosure;

[0049] Fig. 33 shows a side view of the exhaust pipe of Fig. 32; and

[0050] Fig. 34 shows the stinger portion of the exhaust pipe of Fig. 32.

DETAILED DESCRIPTION OF THE DRAWINGS

[0051] For the purposes of promoting an understanding of the principals of the invention, reference will now be made to the embodiments illustrated in the drawings, which are described below. The embodiments disclosed below are not intended to be exhaustive or limit the invention to the precise form disclosed in the following detailed description. Rather, the embodiments are chosen and described so that others skilled in the art may utilize their teachings. It will be understood that no limitation of the scope of the invention is thereby intended. The invention includes any alterations and further modifications in the illustrative devices and described methods and further applications of the principles of the invention which would normally occur to one skilled in the art to which the invention relates.

[0052] With reference first to FIGS. 1-7, a snowmobile is shown at 2 to generally include a front outer body 4, a frame 6, an operator's seat 8, a propulsion system 10 (FIG. 3) coupled to the frame 6, an endless track 12 coupled to the propulsion system 10 for driving the snowmobile, and a steering system 14 coupled to steerable skis 16. The snowmobile 2 further comprises an air intake system 20 (FIG. 2) coupled to an engine of the propulsion system 10, and front 24 and rear 26 suspensions. Snowmobile

2 further includes left and right footrests 30 and 32 (FIG. 5) for the placement of the left and right feet of a driver while riding. Snowmobile 2 further includes a cooling system including a rear cooling portion 40 (FIG. 4). Cooling system of snowmobile 2 is similar to that shown in US Patent 8,567,546. Snowmobile 2 further includes a snowmobile drive system 42 (FIG. 29).

[0053] With respect to FIGS. 8-14, air intake system 20 will be described in greater detail. With reference first to FIGS. 8 and 9, air intake assembly 20 is shown incorporated into the body styling. That is, the front outer body 4 includes an upper body panel 46 (FIG. 9), rear panel 52, side panel 54, and hood 56. The air intake assembly 20 including a plenum assembly 50, which intersects with rear panel 52, side panel 54, and hood 56 in a cohesive fashion, and is partially defined by upper body panel 46. Plenum assembly 50 includes air intake vents 60 as described further herein. The upper body panel 46, rear panel 52, and side panel 54, are fixed relative to the chassis or frame 6, whereas hood 56 is movable relative to frame 6 to access an engine compartment.

[0054] As shown best in FIG. 10, plenum assembly 50 includes a rear edge 66, which conforms to panel 52 as best shown in FIG. 8. Plenum assembly 50 includes integral brackets at 70 on either side thereof for mounting plenum assembly 50 to the snowmobile frame. A slot 72 is provided to allow access for a steering post of steering assembly 14.

[0055] With reference now to FIG. 11, plenum assembly 50 is shown as having an upper plenum housing 80 and a lower plenum housing 82. Upper plenum housing 80 includes a front wall 84 defining a lower peripheral edge 86. Lower plenum housing 82 includes a perimeter wall 90 defining an upper plenum edge at 92. It should be appreciated that walls 84 and 90 complement each other with edges 86, 92 conforming to provide a sealed plenum housing when coupled together. As shown in FIG. 11,

fasteners such as 96 are provided, which are received through lower plenum housing 82 to be received in threaded bosses on an underside of upper plenum housing 80. Lower plenum housing 82 includes an air exit port 100 having an opening at 102 as described herein. It should be appreciated that once coupled together, upper and lower plenum housings 80, 82 provide for a closed air box with the only intakes being provided by vents 60 and the only air exit being provided by opening 102. That is, passageways 104 are created that channel air forwardly from vents 60 to opening 102.

[0056] With reference now to FIGS. 9 and 10, the entire air intake system 2- is shown where plenum 50 is shown coupled to a first duct 120, which is coupled to a second duct 122, which in turn, is coupled to air box 124. Ducts 120 and 122 will be described in greater detail with reference to FIGS. 12, 13A and 13B. As shown in FIG. 12 and 13B, duct 120 includes a molded porous duct portion 130 coupled to a molded porous duct portion 132. As shown, duct portion 130 includes integrated mounting tabs 134, which provide apertures 136 for mounting to lower plenum housing 82. More particularly, and as shown in FIG. 11, fasteners 138 are receivable in apertures 136, which may then be received in threaded bosses 140 of lower plenum housing 82. Duct 120 defines a first opening at 144 (FIG. 12), which corresponds to opening 102 of lower plenum housing 82. A seal may be positioned between openings 102, 144 to better seal the interconnection between the interface of openings 102, 144. Duct 120 further defines an opening at 150 (FIG. 12), which couples to duct 122. Opening 150 is provided with a surrounding latching component 152 having a ramped surface, thereby providing a locking edge when inserted into duct 122 as shown herein.

[0057] Duct 122 is better shown in FIG. 13A as having a molded porous duct portion 160 and a molded porous duct portion 162. Porous portion 160 includes an opening at 164 to couple with opening 150 on duct 120 and opening 166 to couple with air box 124. Opening 166 is defined by a molded polyethylene portion ultrasonically welded to the porous portion. It should be understood that either duct could include a molded portion (polyethylene or other material) coupled to the porous portion in order to rigidify the duct in any place required. As shown, duct portion 160 includes an outer peripheral flange at 170 and duct portion 162 includes an outer peripheral flange at 172,

which is complementary to flange 170. Duct portions 160 and 162 can therefore be coupled, for example, by sonic welding at the flanges 170 and 172.

5 **[0058]** With reference now to Figs. 11 and 12, air box 124 will be further described. Air box 124 includes an upper housing portion 180 and a lower housing portion 182. Upper housing portion 180 includes intake opening at 184 and lower housing 182 includes openings 186, which would be coupled to throttle bodies of the snowmobile engine. Duct 122 would be coupled to air box 124 by way of fastener 190 (FIG. 12) attached to threaded boss 192. Air box 124 would include therein an air filter as is known in the art.

10 **[0059]** The operation of the air intake system 20 will now be described. As mentioned before, and with reference to FIG. 14, air vents 60 allow air to enter plenum 50 of air intake system 20. Air enters the vents 60 and continues into plenum 50. Air exits plenum 50 through opening 102 (FIG. 11) and continues into duct 120. Air exits duct 120 and enters into duct 122 whereupon it enters air box 124. Air exits openings
15 186 where it is connected to throttle bodies (not shown) and enters through an air intake side of an engine. As the outside portions 132, 162 of ducts 120 and 122 are comprised of a porous material, the sound at the operator's station through the vents is eliminated because the sound is dissipated through the porous material in the engine compartment. Furthermore, the vents face rearwardly towards a rider, but are angled
20 outwardly.

[0060] Thus, the vents can be placed along a fixed portion of the snowmobile body without undue sound effects to the operator. For example, most snowmobiles have the engine air intake attached to the hood, which requires a seal between the hood and intake duct. This seal is violated every time the hood is opened requiring
25 correct placement of the hood over the intake duct. This design also eliminates additional resonators and/or Hemholtz boxes in the engine compartment allowing increased volume for other essential engine components.

[0061] It has been found that the best performance is achieved where the material of duct portions 132 and 162 have a porosity of 30%; however, the sound

dissipation is substantially improved with porosity within the range of 20-40%. Suitable materials for the porous materials could include ultra-high molecular weight polyethylene (UHMWPE), polyester (PET) + polypropylene (PP), high-density polyethylene (HDPE), polypropylene (PP), polytetrafluoroethylene (PTFE), and polyvinylidene fluoride (PVDF). Ethylene vinyl acetate (EVA), polyethersulfone (PES), polyurethane (PU) and PE/PP co-polymer could also be used. In the embodiment shown, the material chosen is a polyester (PET) + polypropylene (PP).

[0062] As shown best in Figs. 15-17, a portion of the frame will now be described in detail. As shown best in FIG. 15, a frame coupler 200 is shown providing coupling attachment to multiple components. As shown in FIG. 15, frame 6 is shown as including a tunnel 202 having a top wall 204 and sidewall 206 to which foot rest 30 is attached. Engine cradle 208 extends forwardly from tunnel 206. Toe clip 210 extends forwardly from footrest 30 and is rigidified by a brace at 212. A mainframe tube 216 extends upwardly to a steering arm and brace 218 extends forwardly to another frame component.

[0063] As shown in Figs. 16 and 17, coupler 200 includes an upwardly extending tubular connection at 220; a downwardly extending tubular coupler at 222; a forwardly extending tab 224; and an L-bracket at 226. L-bracket 226 includes a horizontal bracket portion 228 and a vertical bracket portion 230. As shown in FIG. 16, coupler 200 is coupled to tunnel 202 by way of fasteners 240 (FIG. 16) through apertures 242 (FIG. 17) and into apertures 244 (FIG. 16) on tunnel sidewall 206. Fastener 250 is received through aperture (FIG. 17) 252 and through aperture 254 (FIG. 16) on tunnel top wall 204. Tube 212 can thereafter be received in opening 222a of coupler 222 (FIG. 17) and fastener 260 can be received through aperture 262. In a like manner, tube 216 can be positioned in opening 220a of coupler 220 and fastener 266 can be received through aperture 268. It should be appreciated that the coupling of tubes 212 and 216 into corresponding opening 222a and 220a could include the use of a bonding adhesive. Finally, strut 218 can be coupled to tab 224 by way of fasteners 280, 282 (FIG. 16). Thus coupler 200 allows for the coupling of multiple different frame components, even different sized tubes 212, 216.

[0064] With reference now to Figs. 18-24, the rear cooling portion 40 will be described in greater detail. As shown in Figs. 19-20, the rear cooling portion 40 includes a rear cooler 300, which is shown coupled to a rear control arm 302 of rear suspension. Rear control arm 302 includes lower couplings at 304 attached to upright tubes 306, which couple with brackets 308. Each bracket includes spaced apart plates 310 having apertures 312 there through. A rear bumper 320 is provided having forwardly extending tubes 322 having apertures 324. An insert spacer 330 is provided having apertures at 332. Cooler 300 includes threaded bosses 350 and 352, which are aligned with apertures 312. Rear snow flap 370 includes an upper cover portion 372 and sidewalls at 374, sidewalls 374 including clearance opening at 376.

[0065] Rear cooler 300 is assembled to rear control arm 302 by installing insert spacers 330 into the end of tubes 322 to align apertures 324 and 332. Tubes 322 are then positioned intermediate plates 310 of bracket 308 and fasteners 380 may be inserted through apertures 312, 332 and 324. Rear flap 370 is then positioned over cooler 300 with apertures 376 aligned with apertures 350 and 352. Apertures 350 and 352 are then aligned with fasteners 380; and fasteners 380 may be inserted and threadably received in threaded bosses 350 and 352. As shown best in FIG. 21, a portion of threaded boss extends beyond an end of the cooler 300, which defines end-faces 350a and 352a protruding from a side edge of the cooler 300. Thus, end surfaces 350a and 352a project through apertures 376 and may be flushly received against side surface 310a (FIG. 20) such that bracket 308 is fixed firmly against cooler 300 with apertures 376 only providing clearance for bosses 350, 352. A rear flap 390 may be attached to rear snow flap 370 by way of fasteners through corresponding apertures 392, 394 and 396, 398.

[0066] With reference now to Figs. 21-24, cooler 300 will be described in greater detail. Cooler 300 is generally comprised of an extrusion extruded along an axis 400. The extrusion defines internal ribs 404, 406 and 408, defining channels 410A, 410B, 412, 414, and 416. The extrusion process also defines a plurality of fins at 418. As shown best in FIG. 22, cooler 300 includes an insert at 430 defining an inlet at 432, an outlet at 434 and a separating rib 436 (see Figs. 23 and 24) intermediate the inlet 432

and outlet 434. Insert 430 further includes a top plate 440 and a front plate 442. An opening 444 may be cut in cooler 300 to receive insert 430 whereby divider rib 436 is positioned in channel 410 dividing the channel into inlet and outlet portions 410A, 410B. As shown in FIG. 24, portions of the ribs 404, 406, and 408, are cut away at 404a, 406a, and 408a (at each end) thus defining passageways between each of the channels.

[0067] Therefore, and with reference still to FIG. 24, water may flow into channel 410A and into any of channels 412, 414, or 416, and be returned to channel 410B and exit through outlet 434 (FIG. 22). End plates 460 may be positioned into openings 462 and held in place by adhesive or welding or any other means known in the art.

[0068] With reference now to FIGS. 25-28, front suspension 24 will be described in greater detail. Front suspension 24 is similar to the front suspension shown and described in US Patent 8,225,896.

[0069] With reference first to FIG. 25, snowmobile 2 includes a front bulkhead 500 comprised of mirror image cast members 502, 504. The front suspension 24 is coupled to bulkhead 500. For example, front suspension 24 includes an upper A-arm 506 and a lower A-arm 508 each of which is coupled to the left cast member 502. Counterpart A-arms similar to 506, 508 (shown in FIG. 2) are coupled to casting 504. Upper A-arm 506 and lower A-arm 508 are coupled by their outer ends to a spindle 510 (FIG. 1) which in turn couples to steerable ski 16. Upper A-arm 506 has inner couplings 512, 514 coupled to casting 502 and lower A-arm 508 has inner couplings at 516, 518 coupled to casting 502. Couplings 512, 514, 516 and 518 are coupled to casting 502 by way of fasteners 520 such as bolts or studs, and nuts.

[0070] With reference now to Figs. 26, 27, and 27A couplers 512, 514 will be described in greater detail. As shown, coupler 512 includes a coupling tube 520, sleeve 522, thrust washer 524 and coupling arm 526. As shown, coupling tube 520 includes an inner diameter 530 and an outward edge at 532. Sleeve 522 includes a cylindrical portion 540 having an outer diameter at 542 and an inner diameter at 544. Sleeve 522 includes an outer lip 550 having an inner surface 552 and an outer surface 554. Arm

526 includes a center cylindrical portion 560 having flat surfaces 562 at one end and flat surfaces 564 at the opposite end. Thrust ring or lip 566 is positioned between the flat surface of 564 and cylindrical portion 560 and includes a thrust surface 568. Arm 526 further includes slotted openings 570 at one end and slotted openings 572 at the opposite end. Cylindrical portion 560 includes outer diameter at 576. Thus openings 570 and 572 are elongated in the longitudinal direction of arm 526, or along axis 580 (FIG. 27A). It should be appreciated that coupler 514 is identical in assembly components, that is including sleeve 540, washer 524 and arm 526, the components however are simply reversed as that described above with reference to coupler 512 as will be described herein.

[0071] As shown in Figs. 27A and 28, sleeve 540 is positioned in coupling tube 520 with outer surface 542 positioned within opening 530 of coupling tube 520. Inner surface 552 of sleeve lip 550 abuts outer surface 532 of coupling tube 520. Arm 526 is positioned within sleeve 540 with outer diameter 576 positioned against inner diameter 544 of sleeve 540 and with thrust washer 524 positioned intermediate surfaces 554 (FIG. 27A), and 568. Thus as any of the surfaces 568, 524A, 524B, 554, 552 or 532 begin to wear, fasteners 520 (FIG. 25) may be loosened and arm 526 may be moved to the right or in the direction of arrow 590 as shown in FIG. 27. The same goes for coupler 514 whereby arm 526 may be moved in the direction of arrow 600 as shown in FIG. 27. However, in the embodiment shown, the thrust washer has a lower hardness than the sleeve 540 and the arm 526, such that the wear is defined at the thrust washer. The wear could be defined at the sleeve, by having the sleeve hardness lower than the arm 26 and washer 524.

[0072] With reference now to FIGS. 29-31, the snowmobile drive system 42 will be described in greater detail. It should be appreciated snowmobile drive system 42 is similar to that disclosed in US Publication 20130032419.

[0073] With reference first to FIGS. 29-30, front bulkhead 500 is shown coupled to a snowmobile front frame portion 208, also referred to as an engine cradle, which includes frame portion 650 extending forwardly from snowmobile tunnel 202. The frame portion 650 supports a first drive member 654 including pulley 655 (FIG. 29) which is coupled to driveshaft 656 (FIG. 30) which in turn drives a driveshaft 658. Driveshaft 658 is coupled to driveshaft 656 by way of sprockets 660 and 662 driven through chain 664.

[0074] As shown best in FIGS. 30 and 31, frame portion 650 includes a forwardly extending leg portion 700 having a gear casing 702 coupled to a rear end thereof, and a mounting bracket 704 at a front end thereof. Casing 702 includes a peripheral wall 706 which defines an inner volume to the casing forward of a rear wall 708. Apertures 710, 712 extend through wall 708 and form openings for jackshaft 656 and driveshaft 658. Casing 702 defines a volume for receiving gears 660, 662 as shown best in FIG. 30. Casing 702 includes a plurality of bosses 716, as described herein.

[0075] A cover 720 has a peripheral edge 722 having a geometry which coincides with wall 706. Cover 720 includes an inner groove 724 for receiving a seal to receive an edge of wall 706 therein for a sealed connection therewith. Cover 720 further provides a plurality of bosses 726 which correspond with bosses 716 for receiving fasteners 728 there through. Cover 720 further provides an opening 730 corresponding to opening 710, providing access for a brake disc 740 mounted to shaft 656.

[0076] With reference now to Figs. 32-34, a new exhaust pipe will be described in greater detail. As shown, an exhaust pipe is shown at 800 having an inlet 802 and an outlet at 804. Exhaust pipe 800 includes an outer tube 806 and an internal stinger tube at 808. As shown in Figs. 32 and 33, internal stinger tube 808 is curved along an axis symmetric with the outer tube 806. Components of the outer tube include a header 810, reverse bend 812, diffuser 814, expansion chamber 816, and rear cone 818.

[0077] An internal stinger in a 2-stroke tuned pipe serves multiple purposes. Both to provide an area change for wave reflection and to create an artificial baffle in the

convergent tail cone of the pipe serving to reduce the sound output both in absolute intensity and in frequency.

5 **[0078]** High performance 2-stroke engines have, historically, featured an axisymmetric convergent rear cone with a stinger concentric with the rear cone centerline axis. The reduction in both the overall engine area space and the longitudinal distance of the front section of the vehicle chassis will eliminate the ability to include a straight, concentric stinger design with an acceptable rear convergent cone length.

10 **[0079]** As shown herein, a curved, either as single radius or a compound, multi-dimensional bend allows integration of an internal stinger of sufficient length which is concentric with the convergent rear cone at any given centerline position. This allows for both the sound damping capabilities of the internal stinger as well as the reflection and wave dynamic requirements of the convergent rear cone to co-exist within a smaller overall vehicle package.

15 **[0080]** Utilizing a curved or compound 3-dimensional bent internal stinger allows for the stinger to remain concentric with the rear cone centerline allows effective use of the sound reduction capabilities of the stinger and the wave dynamic requirements of the rear cone without introducing non symmetric, 2 dimensional localized gas flow and wave reflection within the tuned pipe rear cone.

20 **[0081]** The curved internal stinger can be made either from bent tubing; with or without formed ends for joining to the convergent cone or multi-angle 3-dimensional resolved geometry made in two halves (see Fig. 34) and seam joined along side edges 820. The utilization of multi-angle, multi-dimensional complex geometry in tuned pipe cone design as subsequently stinger design will permit smaller vehicles and more compact packaging.

25 **[0082]** The use of this type of internal stinger will help achieve acceptable sound levels without the need to compensate for the lack of a stinger with the utilization of larger silencers and/or increasing numbers of silencer resonant chambers.

[0083] Furthermore, non-axisymmetric stinger design, which allows for a stinger which is concentric with the rear cone at any given position, attains more consistent thermal gradients along both the centerline and the radial distance at a given axis position. This creates more predictable performance, frequency response and operational characteristics.

[0084] While this invention has been described as having an exemplary design, the present invention may be further modified within the spirit and scope of this design disclosure. This application is therefore intended to cover any variations, uses, or adaptations of the invention using its general principles. Further, this application is intended to cover such departures from the present disclosure as come within known or customary practices in the art to which this invention pertains.

[0085] Other aspects of the present disclosure at least relate to the following clauses:

Clause 1. A snowmobile, comprising:
a chassis;
an engine supported by the chassis;
a front suspension coupled to the chassis and to steerable skis;
the front suspension comprising at least one suspension arm; and
couplings coupling the at least one suspension arm to the chassis, the couplings comprising a movable portion mountable to the chassis in multiple lateral positions, relative to the suspension arm for accommodating wear.

Clause 2. The snowmobile of clause 1, wherein the couplings include coupling tubes at their inner ends.

Clause 3. The snowmobile of clause 2, wherein the couplings include a sleeve positionable within the sleeve and having a lip defining an inner most position relative to the coupling tubes.

Clause 4. The snowmobile of clause 3, wherein the couplings include an arm positionable within the sleeve, and having a lip defining an inner most position relative to the sleeve.

5 Clause 5. The snowmobile of clause 4, wherein the arm is coupled to the chassis.

Clause 6. The snowmobile of clause 5, wherein the arm has slotted holes, and fasteners are positioned through the slotted holes and are affixed to the chassis, whereby the arm is movable relative to the sleeve, when the fasteners are loosened,
10 and the arm is movable to remove any slack caused by wear.

Clause 7. The snowmobile of clause 6, further comprising a thrust washer positioned intermediate the lip on the sleeve and the lip on the arm.

15 Clause 8. The snowmobile of clause 7, wherein the thrust washer has a lower hardness relative to the arm and the sleeve, such that the thrust washer is the wear portion.

Clause 9. A snowmobile, comprising:
20 a chassis including a bulkhead and a tunnel;
an engine supported by the chassis;
a coupler attached to the chassis having plural connection points for coupling plural frame braces to the tunnel.

25 Clause 10. The snowmobile of clause 9, wherein the coupler includes cylindrical coupling portions for coupling cylindrical tubular braces.

Clause 11. The snowmobile of clause 10, wherein the cylindrical coupling portions have varying diameters for coupling different diameters of tubes.

30

Clause 12. The snowmobile of clause 11, wherein the coupler comprises a right

angled base portion for coupling to the corner of the tunnel.

Clause 13. A snowmobile, comprising:

a chassis;

5 a water cooled engine supported by the chassis; and

a cooler, the cooler comprising:

a top wall,

a lower wall,

internal ribs connecting the top and lower wall and defining

10 channels, an opening in one of the channels,

an insert having an inlet port, an outlet port and a separating rib,

the insert being positioned in the opening with the separating rib separating the one channel into two divided channel portions, the inlet port communicating with a first divided channel portion and the outlet port communicating with a second divided

15 channel portion, and

side walls positioned between the top and lower wall and enclosing the channels.

Clause 14. The snowmobile of clause 13, wherein the cooler is extruded to define the

20 top wall, lower wall and internal ribs.

Clause 15. The snowmobile of clause 13, further comprising cooling fins on one of the top or lower wall.

25 Clause 16. The snowmobile of clause 13, wherein portions of the ribs are cut away at each end defining passageways between each of the channels.

Clause 17. A snowmobile, comprising:

a chassis;

30 an engine positioned in a front chassis portion and having at least one intake port and at least one exhaust port;

an air intake system coupled to the intake port and comprising a duct being at least partially comprised of a porous material; and

5 an exhaust system comprising an exhaust pipe having a stinger tube and a rear cone which are curved, with centerlines of the stinger tube and rear cone being concentric.

Clause 18. The snowmobile of clause 17, wherein the exhaust pipe further comprises a diffuser and an expansion chamber.

10 Clause 19. The exhaust pipe of clause 17, wherein the stinger and rear cone have a single radius bend.

Clause 20. The exhaust pipe of clause 17, wherein the stinger and rear cone have a compound, multi-dimensional bend.

15

Clause 21. The snowmobile of clause 45, wherein a front body portion is defined over a front chassis portion and defines an engine compartment.

20 Clause 22. The snowmobile of clause 21, wherein a plenum assembly is coupled to the front chassis portion and having at least one intake air vent and at least one air exit opening.

Clause 23. The snowmobile of clause 21, wherein the plenum assembly is defined at least in part by the front body portion.

25

Clause 24. The snowmobile of clause 23, wherein the front body portion comprises at least one upper body panel, rear panel, side panel and hood.

30 Clause 25. The snowmobile of clause 24, wherein the plenum is defined by an upper plenum housing and a lower plenum housing.

Clause 26. The snowmobile of clause 25, wherein the upper body panel defines a top wall of the upper plenum housing.

5 Clause 27. The snowmobile of clause 17, further comprising a second duct and an air box, the second duct being coupled to the first duct, and to the air box.

Clause 28. The snowmobile of clause 27, wherein the air box includes an air filter.

10 Clause 29. The snowmobile of clause 17, wherein the first duct includes a composite of a molded plastic portion and the porous material.

Clause 30. The snowmobile of clause 29, wherein the porous material has a porosity in the range of 20-40%.

15 Clause 31. The snowmobile of clause 30, wherein the porous material has a porosity of approximately 30%.

20 Clause 32. An exhaust pipe, comprising: a diffuser,
an expansion chamber,
a rear cone, and
a stinger tube extending into the rear cone, wherein the stinger tube and rear cone are curved, with centerlines of the stinger tube and rear cone being concentric.

25 Clause 33. The exhaust pipe of clause 32, wherein the stinger and rear cone have a single radius bend.

30 Clause 34. The exhaust pipe of clause 32, wherein the stinger and rear cone have a compound, multi-dimensional bend.

Clause 35. A snowmobile comprising the exhaust pipe of clause 34.

Clause 36. The snowmobile of clause 35, further comprising an air intake system coupled to the intake port and comprising a duct being at least partially comprised of a porous material.

What is claimed is:

1. A snowmobile, comprising:
a chassis, comprising a tunnel, an engine cradle and a bulkhead;
an engine supported by the chassis;
a drive belt supported by the chassis; and
a drive assembly for driving the drive belt, the drive assembly comprising a jack shaft driven by the engine and a drive shaft for driving the drive belt,
wherein a portion of the chassis includes an integrated casing for receiving the jack shaft and the drive shaft therein, and for enclosing sprockets attached to the jack shaft and the drive shaft, and
wherein the engine cradle comprises a frame portion having a continuous surface with the integrated casing and including a mounting bracket configured to directly couple to the bulkhead.
2. The snowmobile of claim 1, further comprising a chain entraining the sprockets.
3. The snowmobile of claim 2, wherein the chain is positioned within the integrated casing.
4. The snowmobile of any one of claims 1 to 3, further comprising a cover to cover the integrated casing.
5. The snowmobile of any one of claims 1 to 4, wherein the integrated casing is integrated with the engine cradle.
6. The snowmobile of any one of claims 1 to 5, wherein the jack shaft drives the drive shaft.
7. The snowmobile of any one of claims 1 to 6, wherein the integrated casing is defined on the frame portion.

8. The snowmobile of claim 7, wherein the frame portion includes a forwardly extending leg portion, the integrated casing being coupled to a rear end of the forwardly extending leg portion and the mounting bracket being coupled to a front end of the forwardly extending leg portion.

9. The snowmobile of claim 8, further comprising a front suspension assembly, and the bulkhead is configured to support the front suspension assembly.

10. The snowmobile of claim 9, wherein the forwardly extending leg portion is positioned longitudinally intermediate the front suspension assembly and the drive assembly.

11. The snowmobile of any one of claims 1 to 3, further comprising a cover configured to couple with the integrated casing and a brake disc mounted to the jack shaft, wherein the cover includes an opening providing access for the brake disc to be mounted to the jack shaft.

12. The snowmobile of any one of claims 1 to 11, wherein the integrated casing includes a first opening and a second opening, the first opening receiving the jack shaft and the second opening receiving the drive shaft.

13. The snowmobile of any one of claims 1 to 12, wherein the integrated casing includes a peripheral wall and a rear wall, and the peripheral wall extends outwardly from the rear wall.

14. The snowmobile of claim 13, wherein a lateral extent of the peripheral wall is at least equal to a lateral extent of the sprockets.

15. The snowmobile of any one of claims 1 to 3, wherein the integrated casing includes a rear wall, a peripheral wall extending outwardly from the rear wall, and a cover configured to sealingly receive a portion of the peripheral wall.

16. The snowmobile of any one of claim 1 to 8, further comprising a footrest and a front suspension assembly each supported by the chassis, and the integrated casing is positioned generally longitudinally intermediate the footrest and the front suspension assembly.

17. The snowmobile of claim 16, wherein at least a portion of the integrated casing extends forwardly of the footrest.

18. The snowmobile of claim 16, wherein a first portion of the integrated casing is at a vertical height greater than that of a portion of the footrest and a second portion of the integrated casing is at a vertical height less than that of the portion of the footrest.

19. A snowmobile, comprising:

a chassis, comprising a tunnel, an engine cradle and a bulkhead;

an engine supported by the chassis;

a drive belt supported by the chassis; and

a drive assembly for driving the drive belt, the drive assembly comprising a jack shaft driven by the engine and a drive shaft for driving the drive belt,

wherein a portion of the chassis includes an integrated casing for receiving the jack shaft and the drive shaft therein, and for enclosing sprockets attached to the jack shaft and the drive shaft, and

wherein the engine cradle comprises a forwardly extending leg portion that is integrally formed and having a continuous surface with the integrated casing.

20. The snowmobile of claim 19, wherein a mounting bracket is coupled to a front end of the forwardly extending leg portion configured for coupling to the bulkhead.

21. The snowmobile of claim 20, wherein the forwardly extending leg portion and the integrated casing form a one-piece assembly extending from at least an aperture for receiving the drive shaft to the mounting bracket.

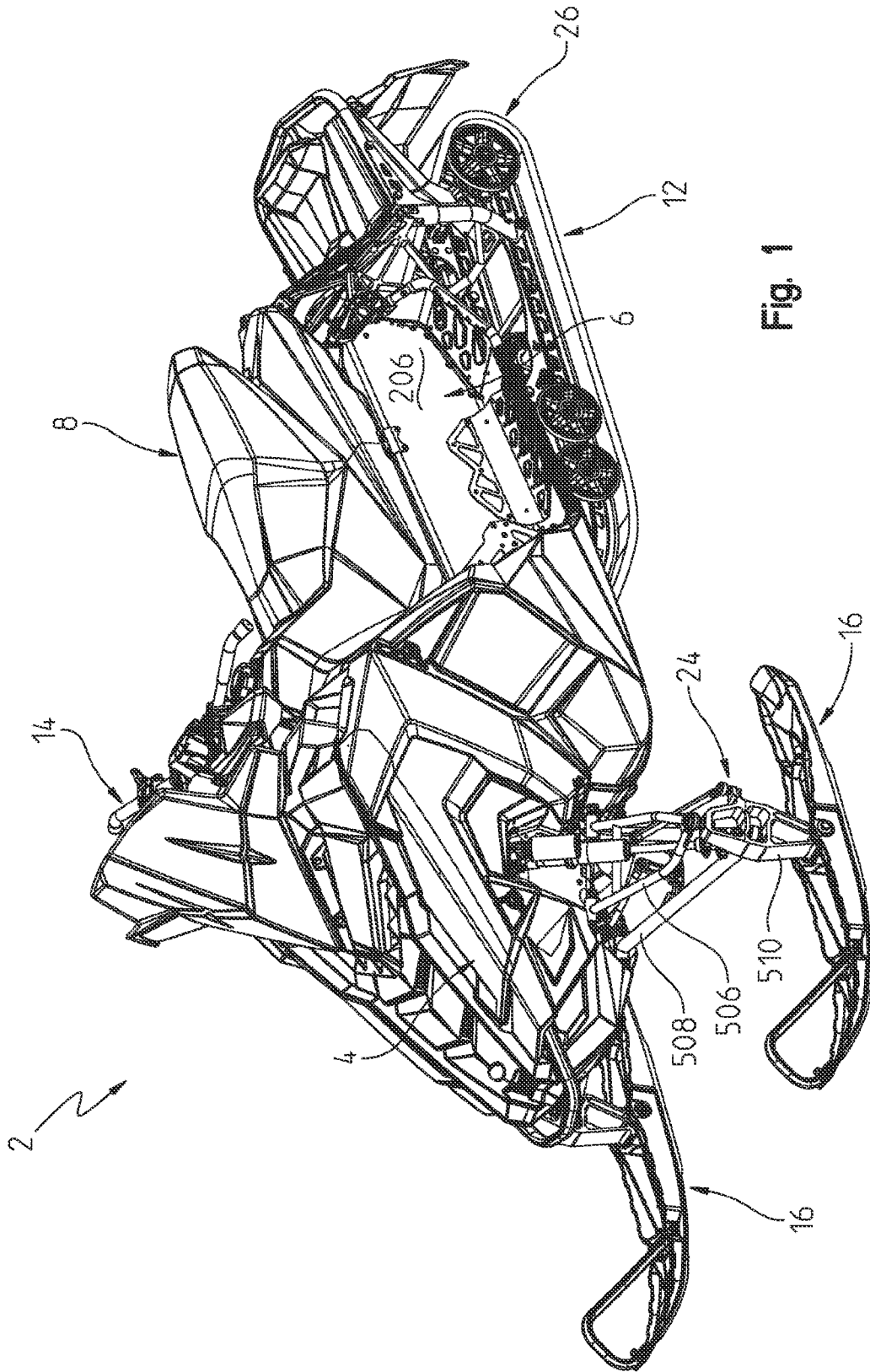

Fig. 1

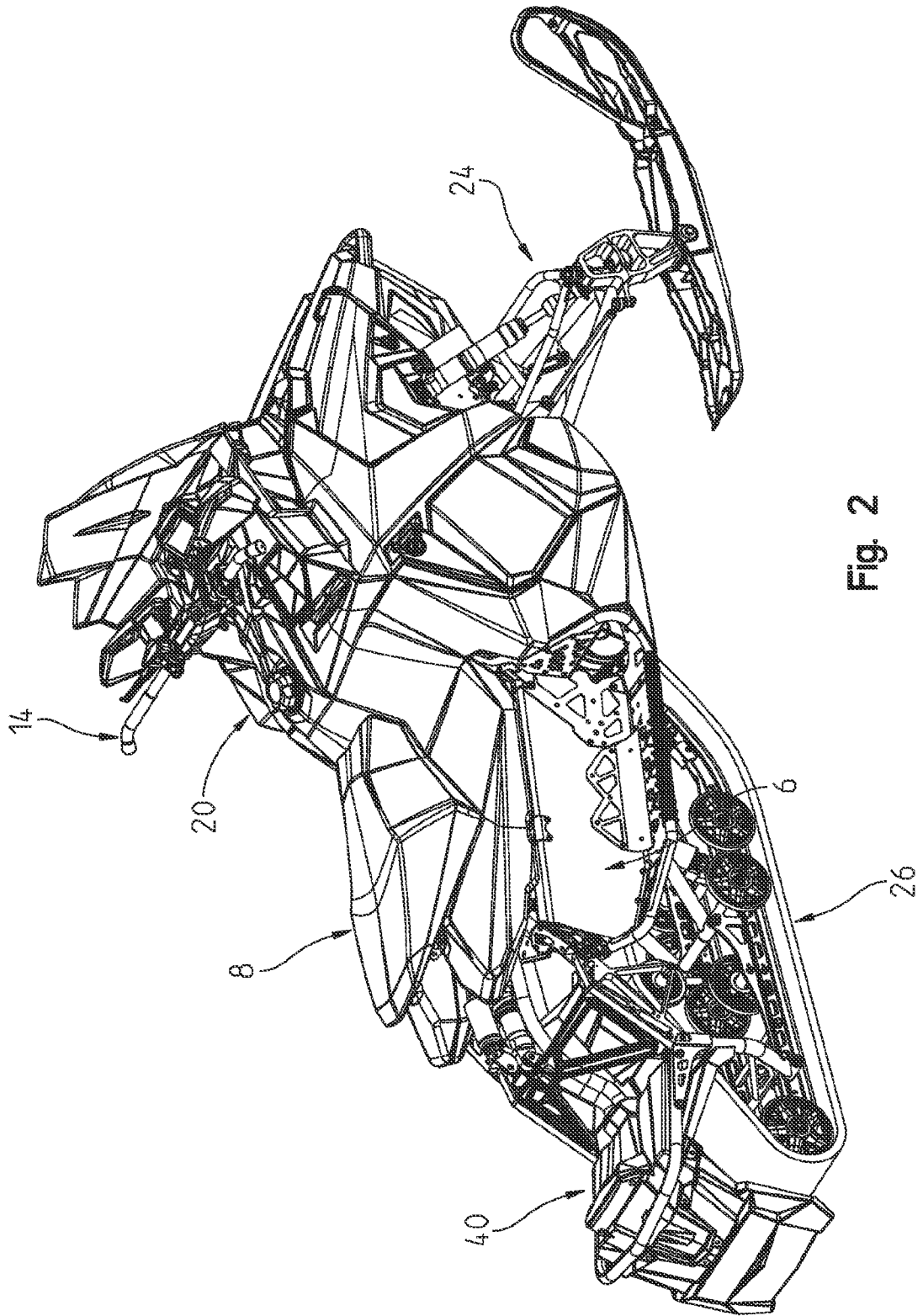

Fig. 2

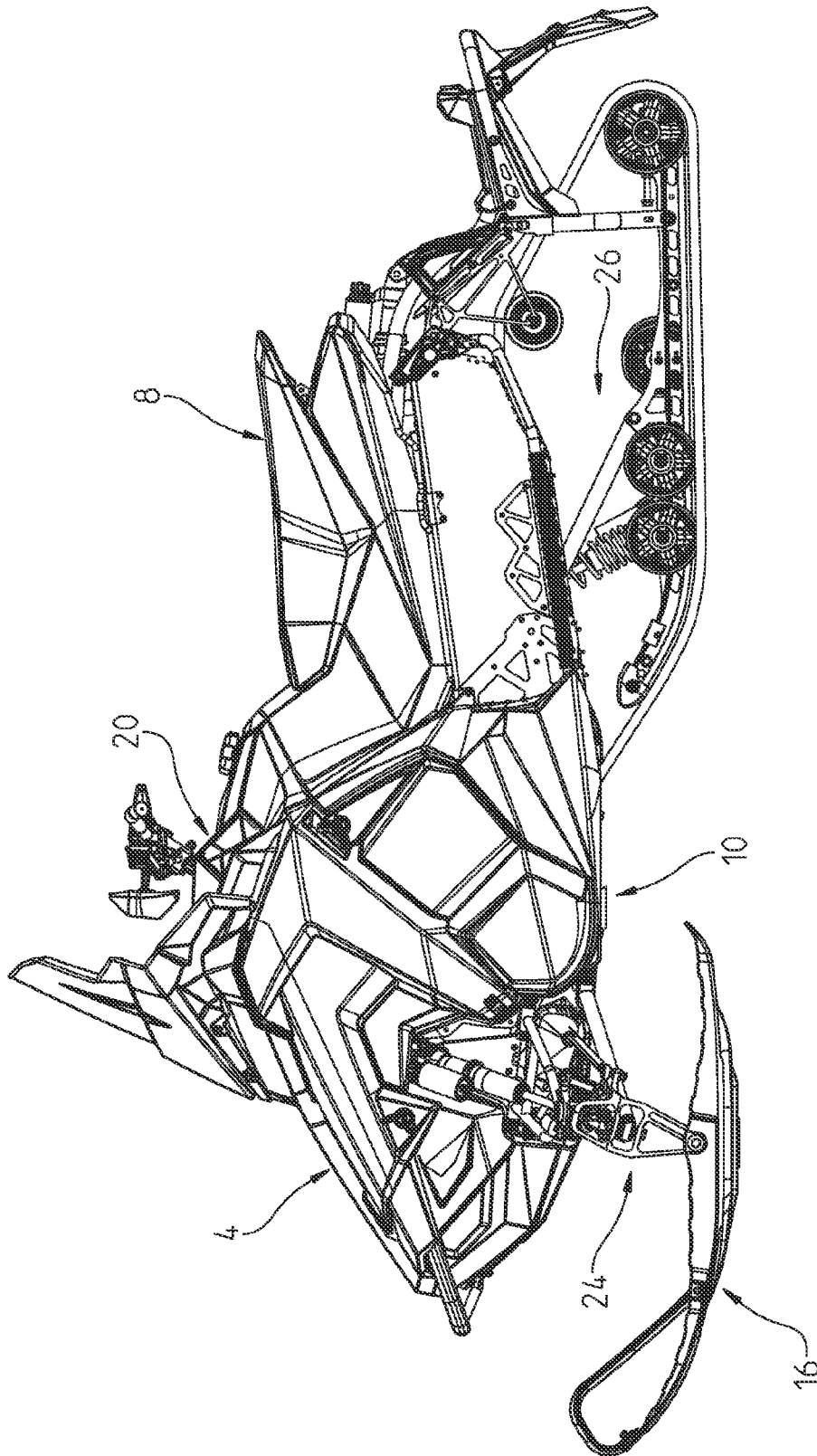

Fig. 3

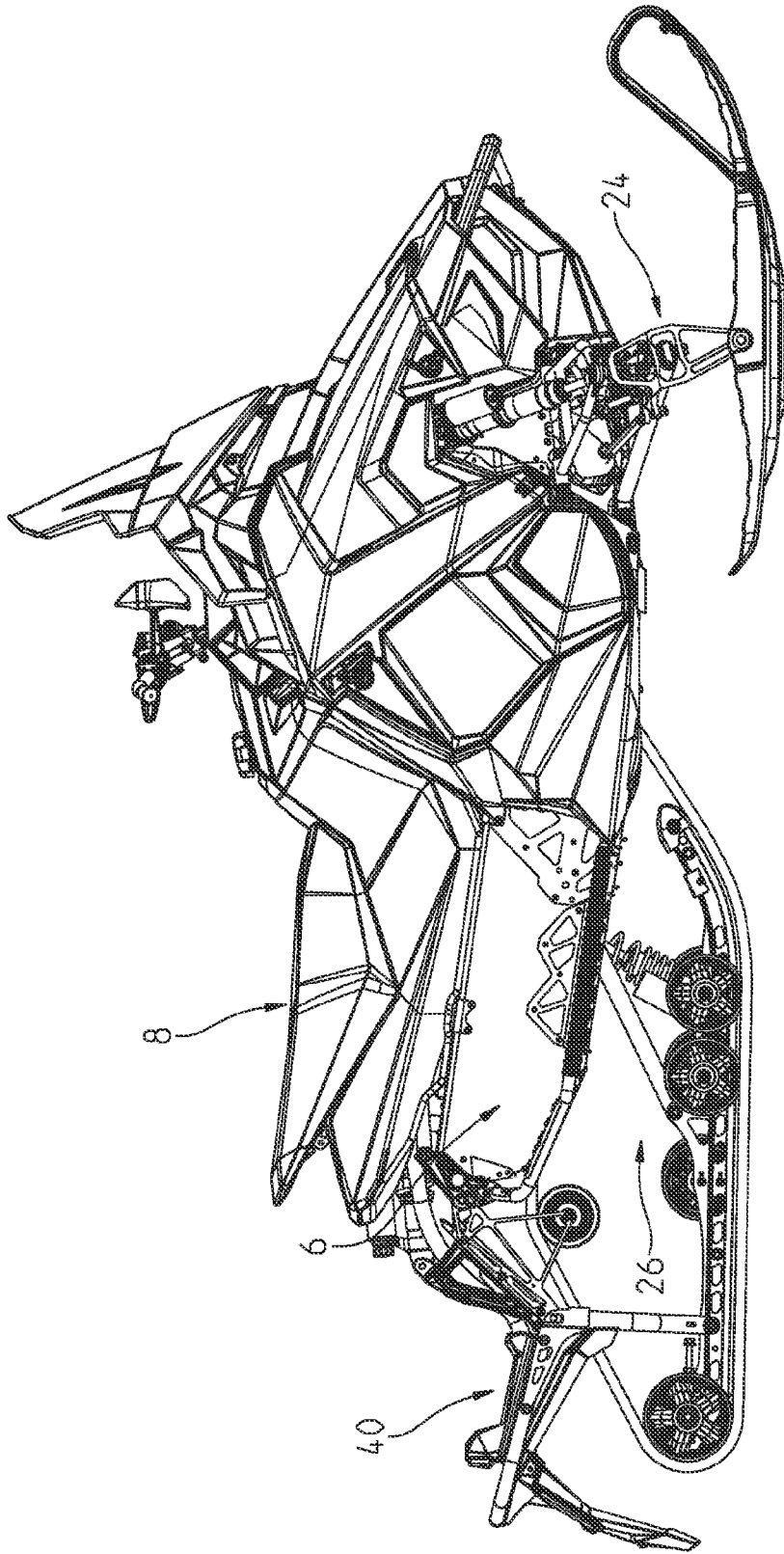

Fig. 4

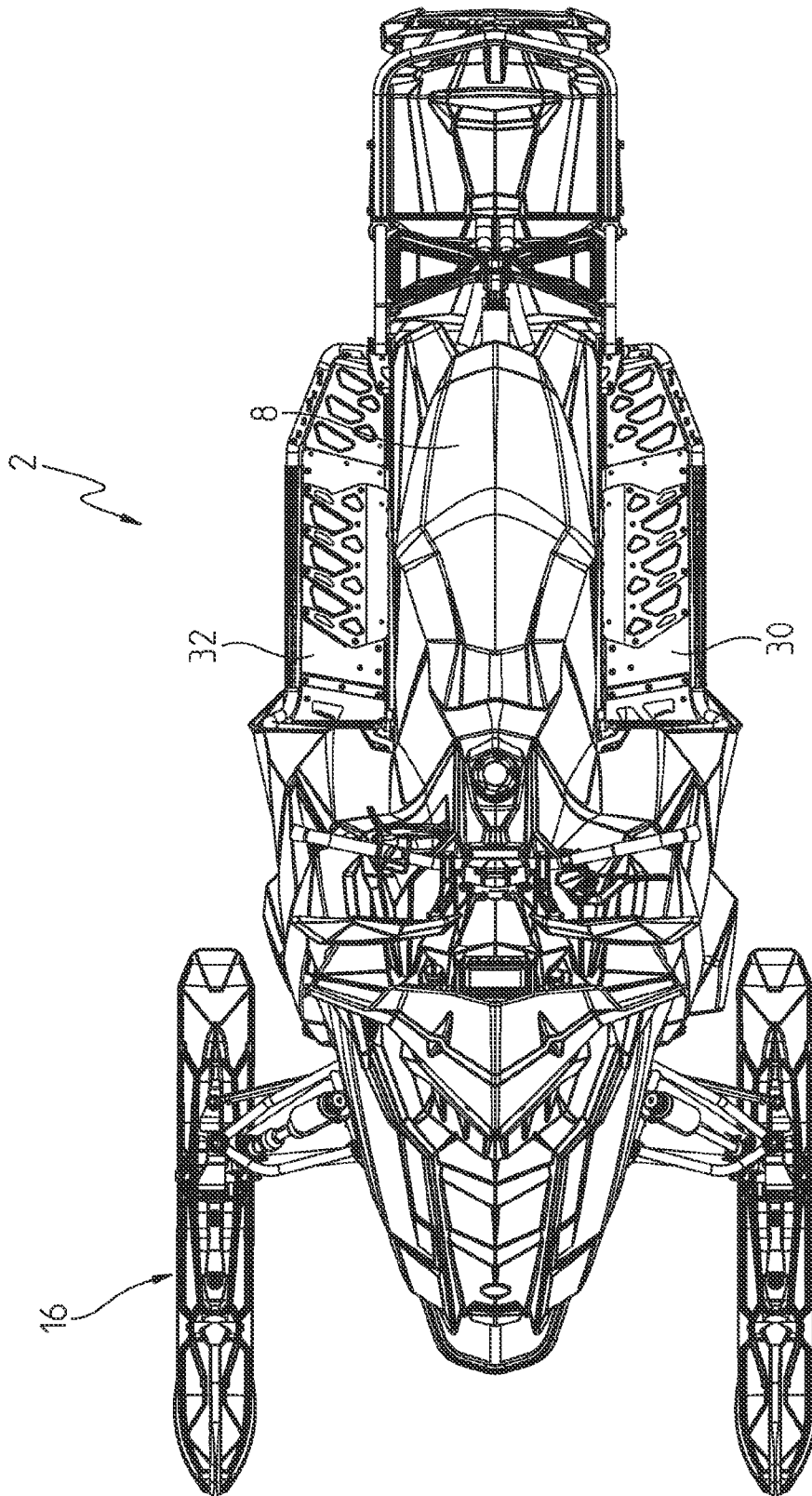

Fig. 5

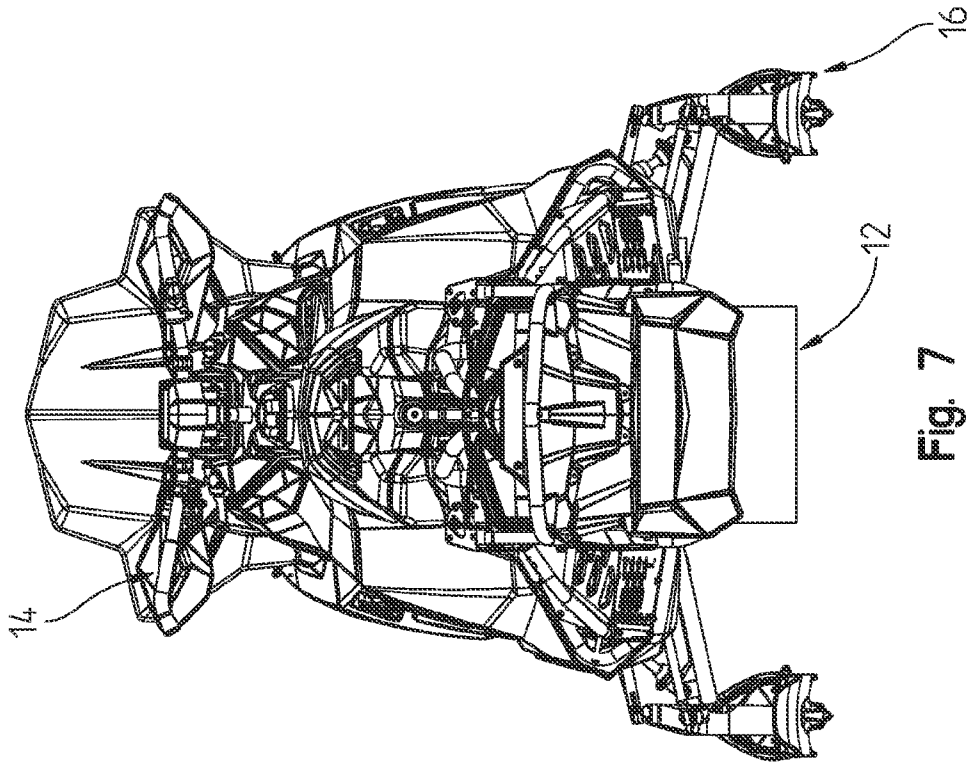

Fig. 7

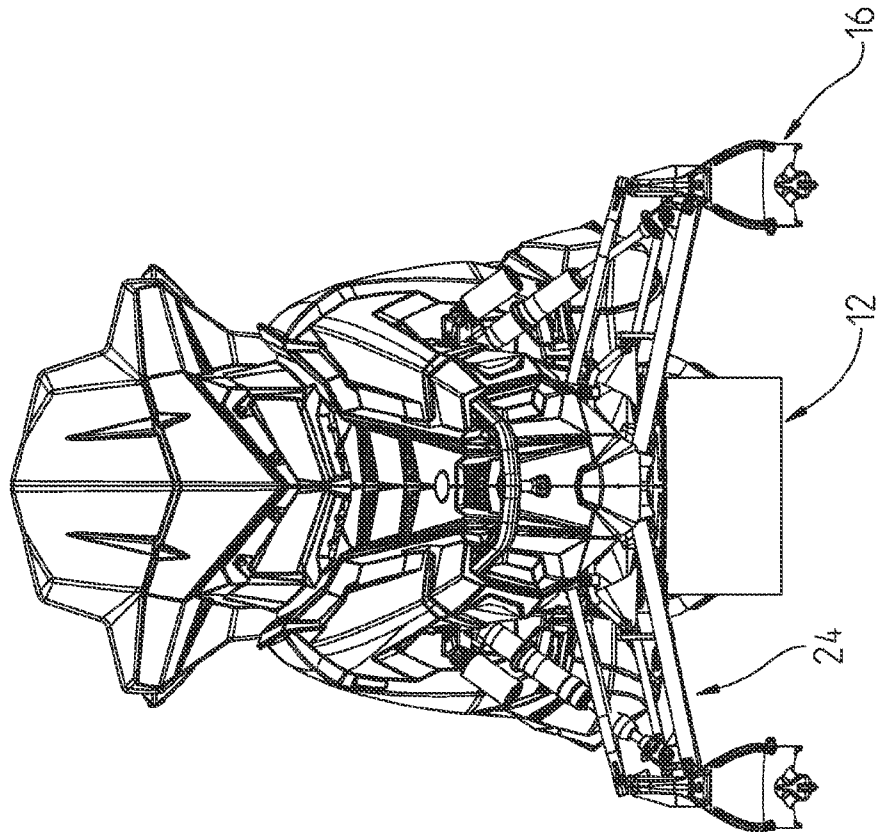

Fig. 6

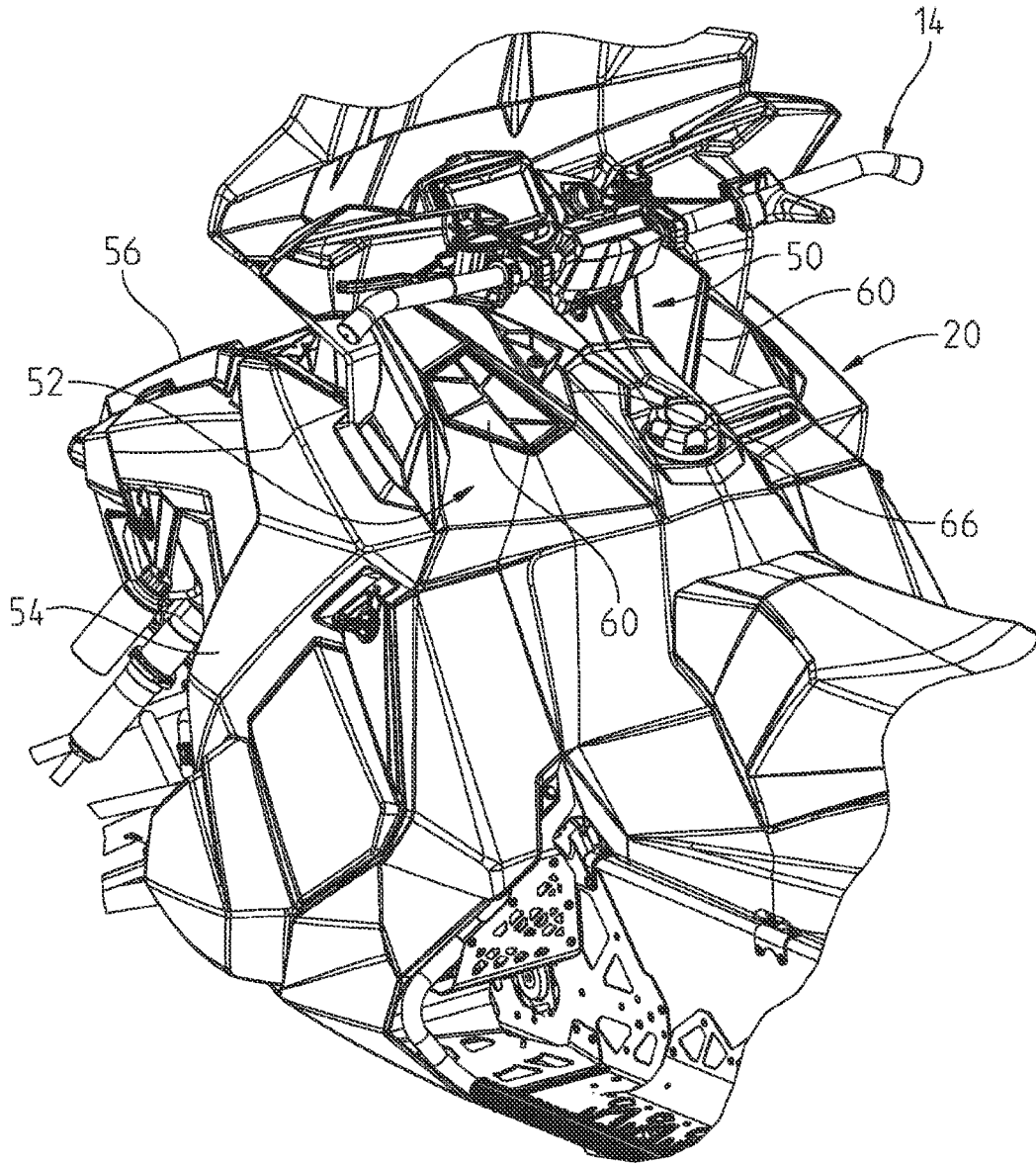

Fig. 8

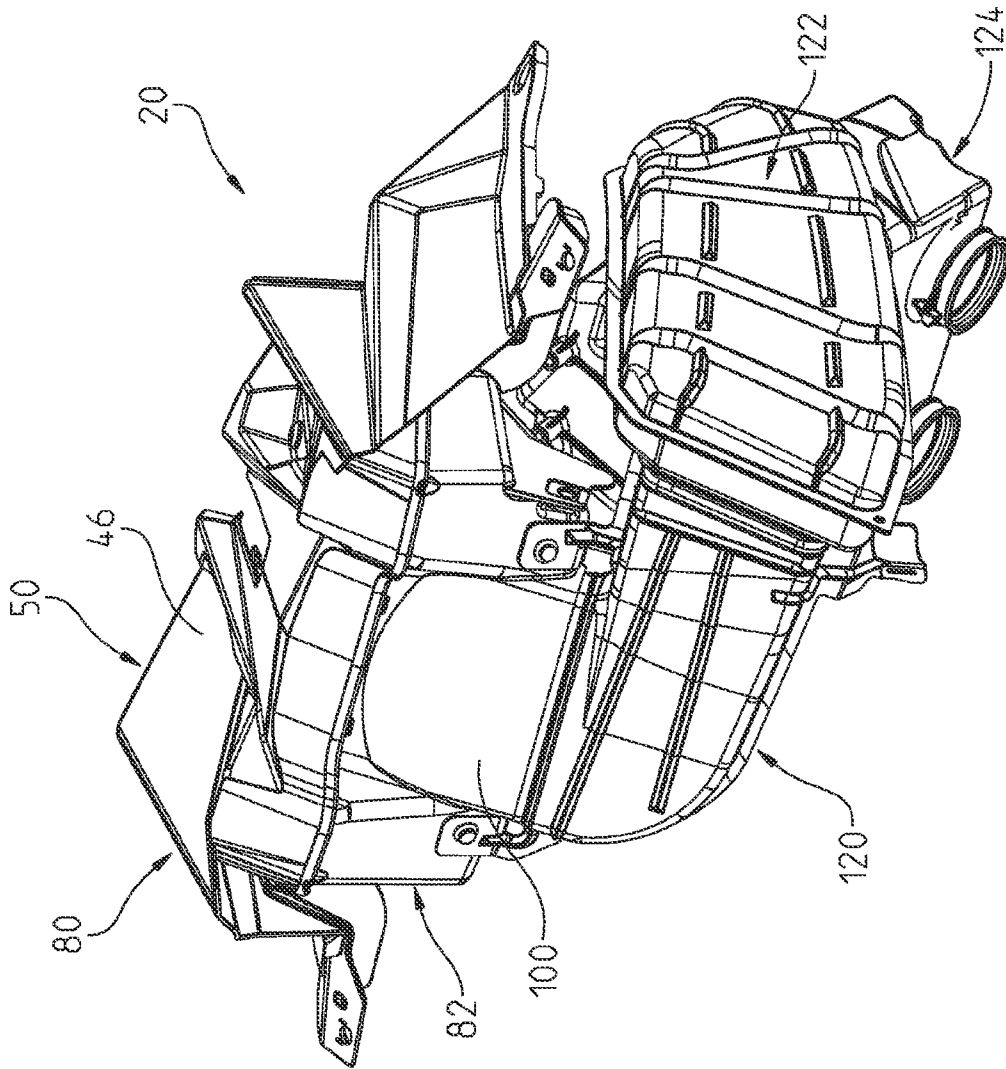

Fig. 9

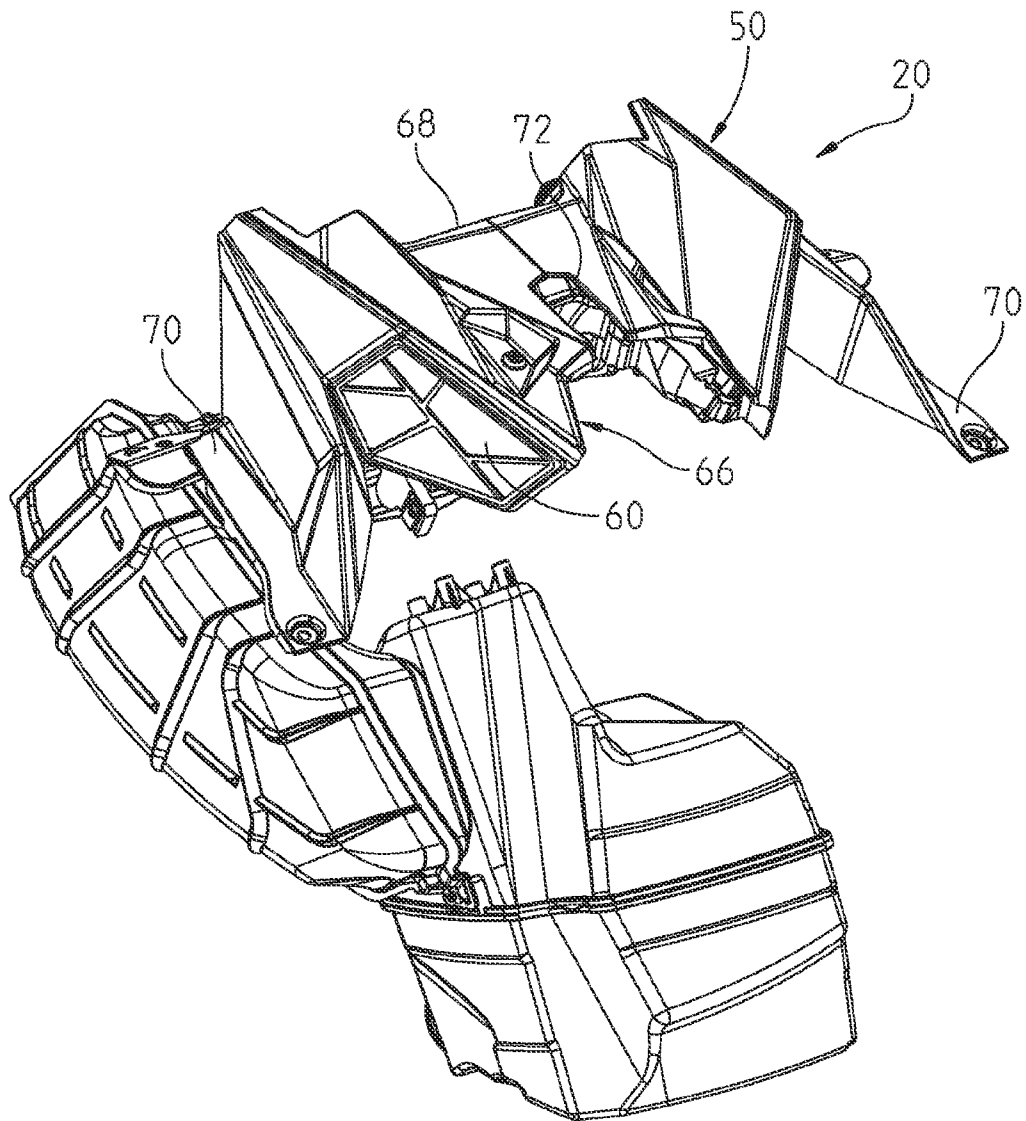

Fig. 10

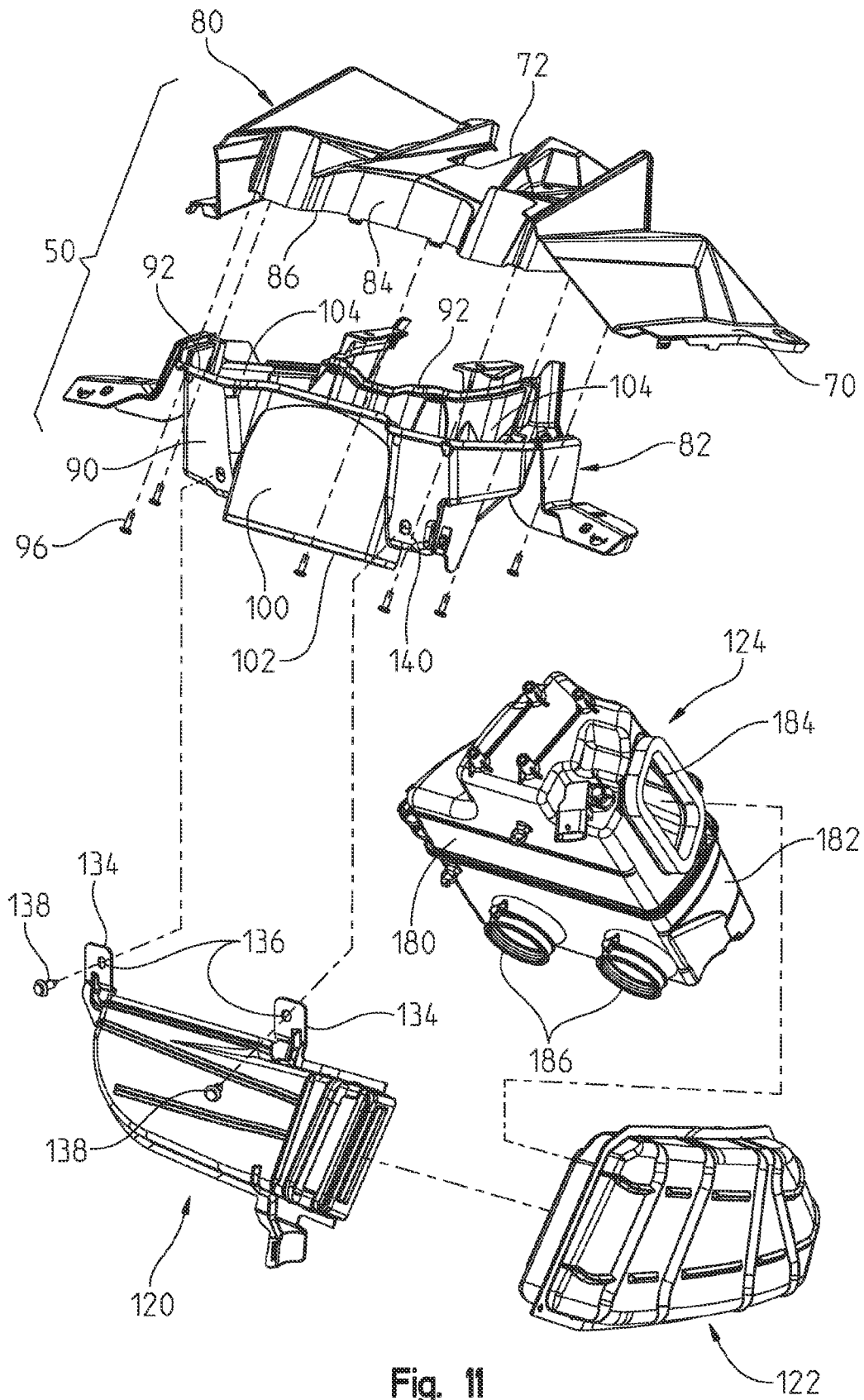

Fig. 11

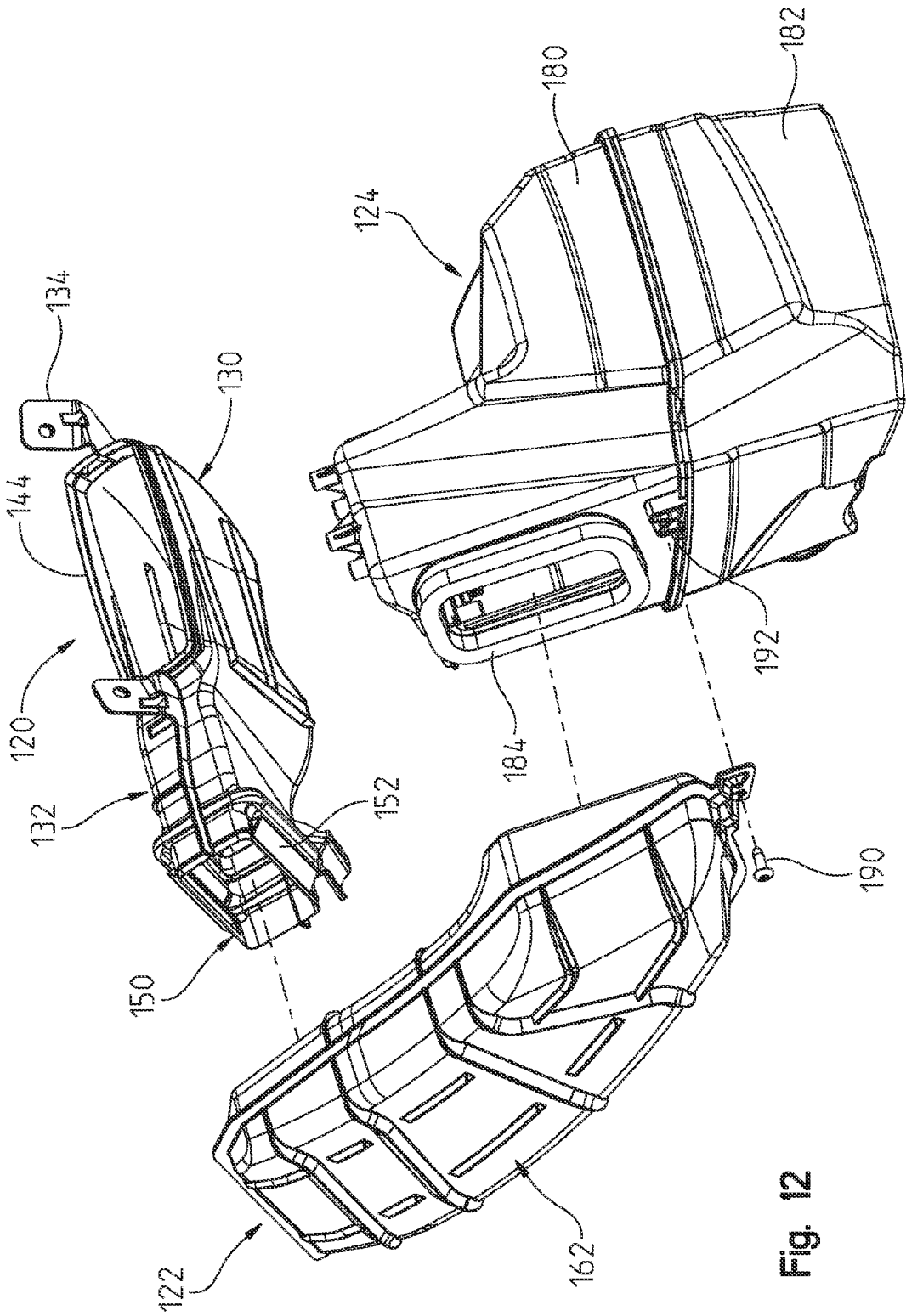

Fig. 12

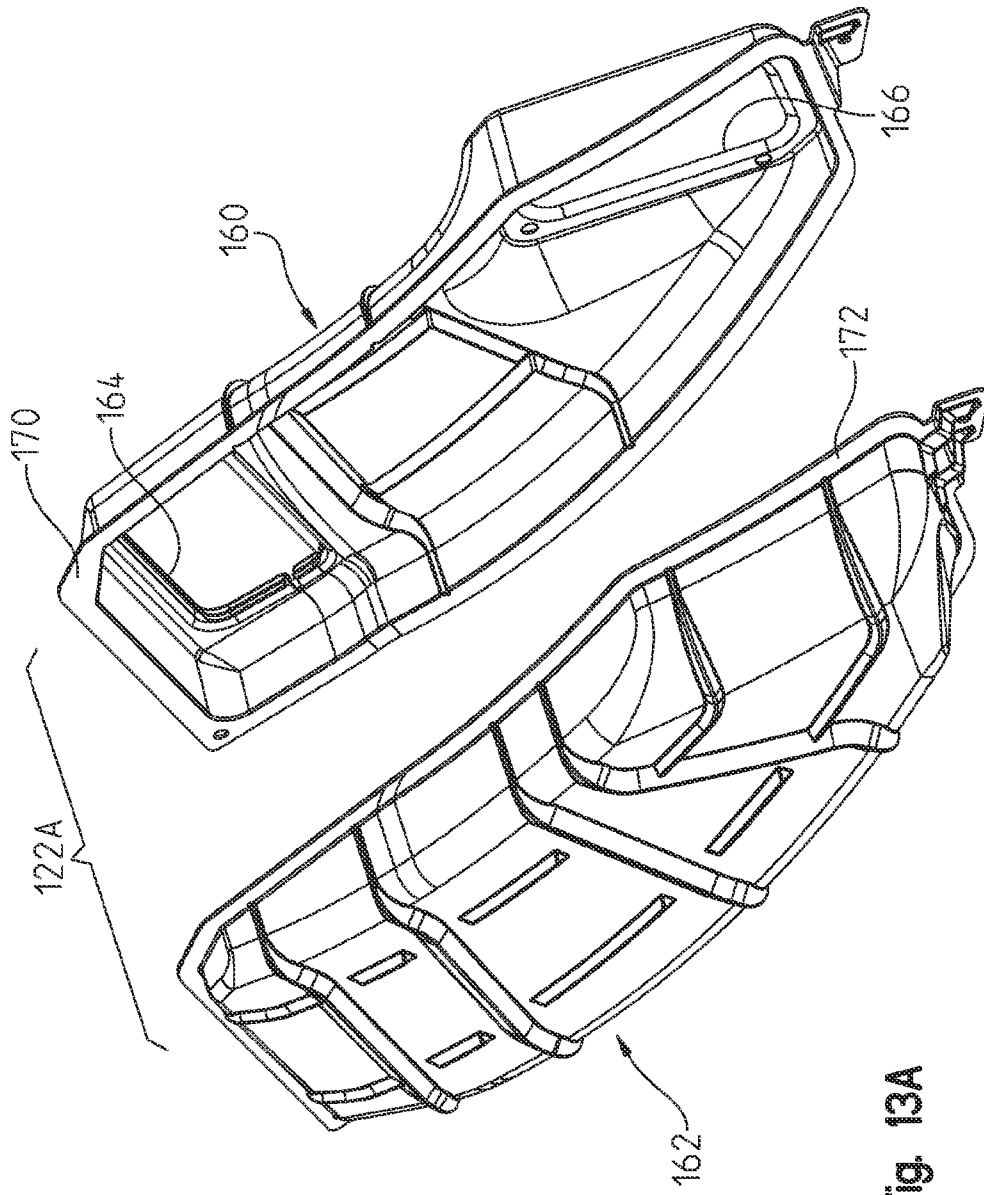

Fig. 13A

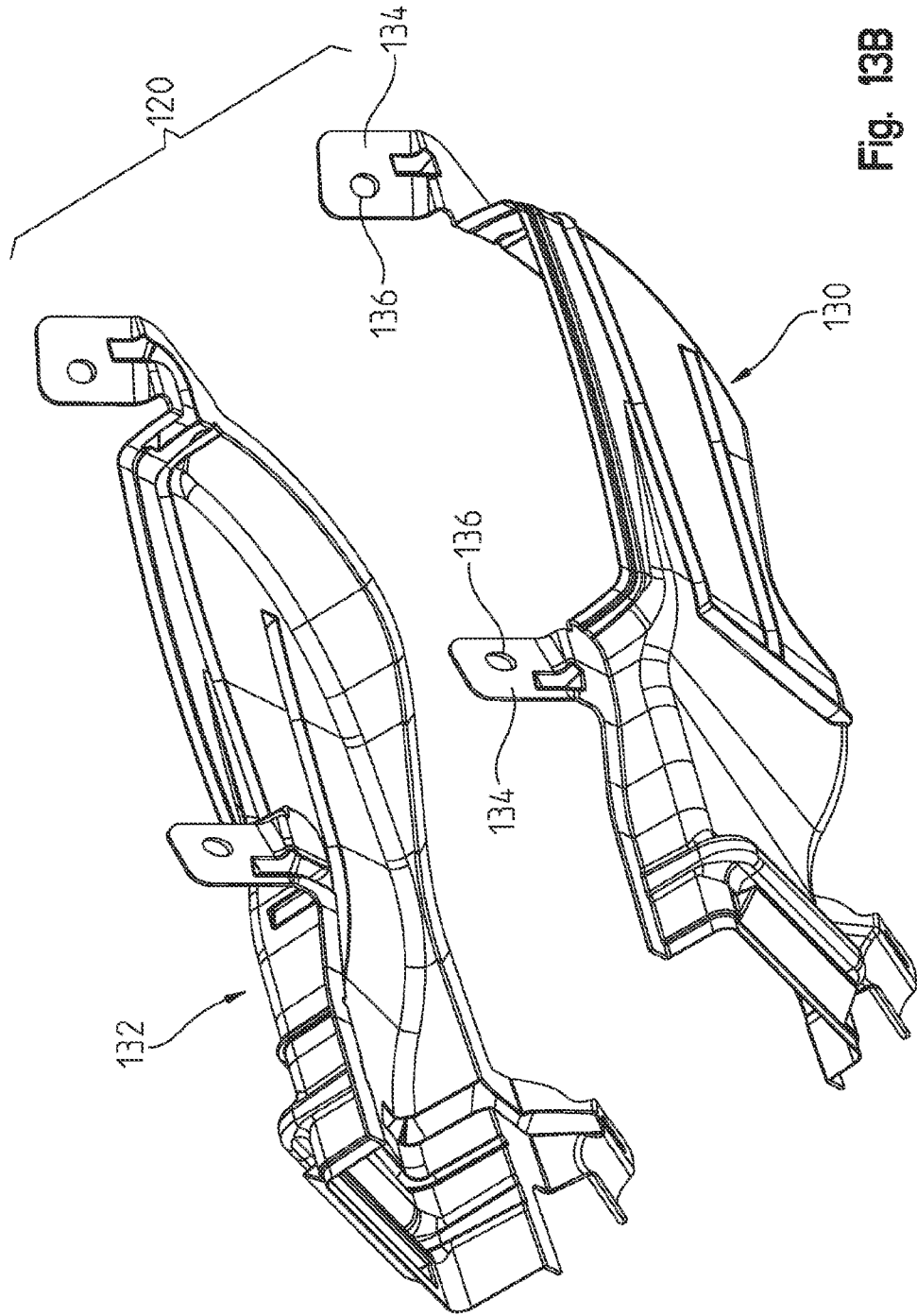

Fig. 13B

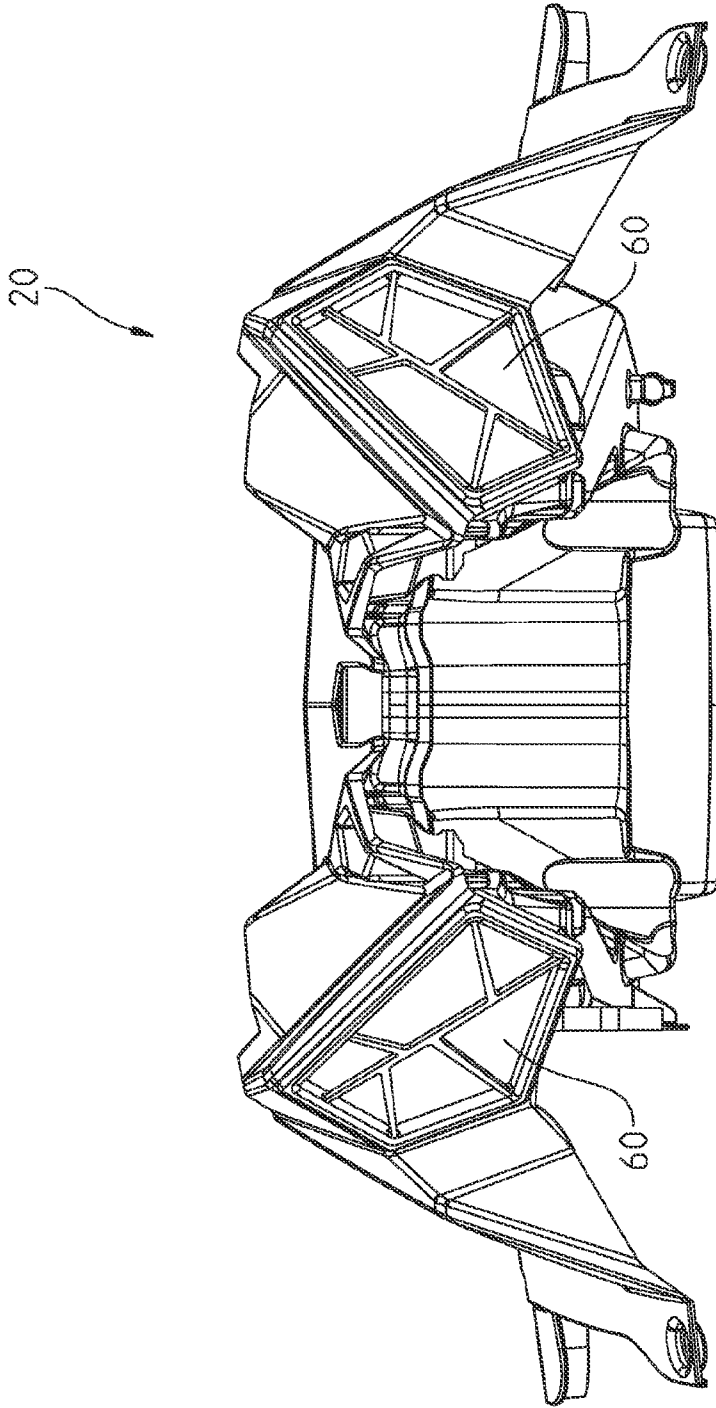

Fig. 14

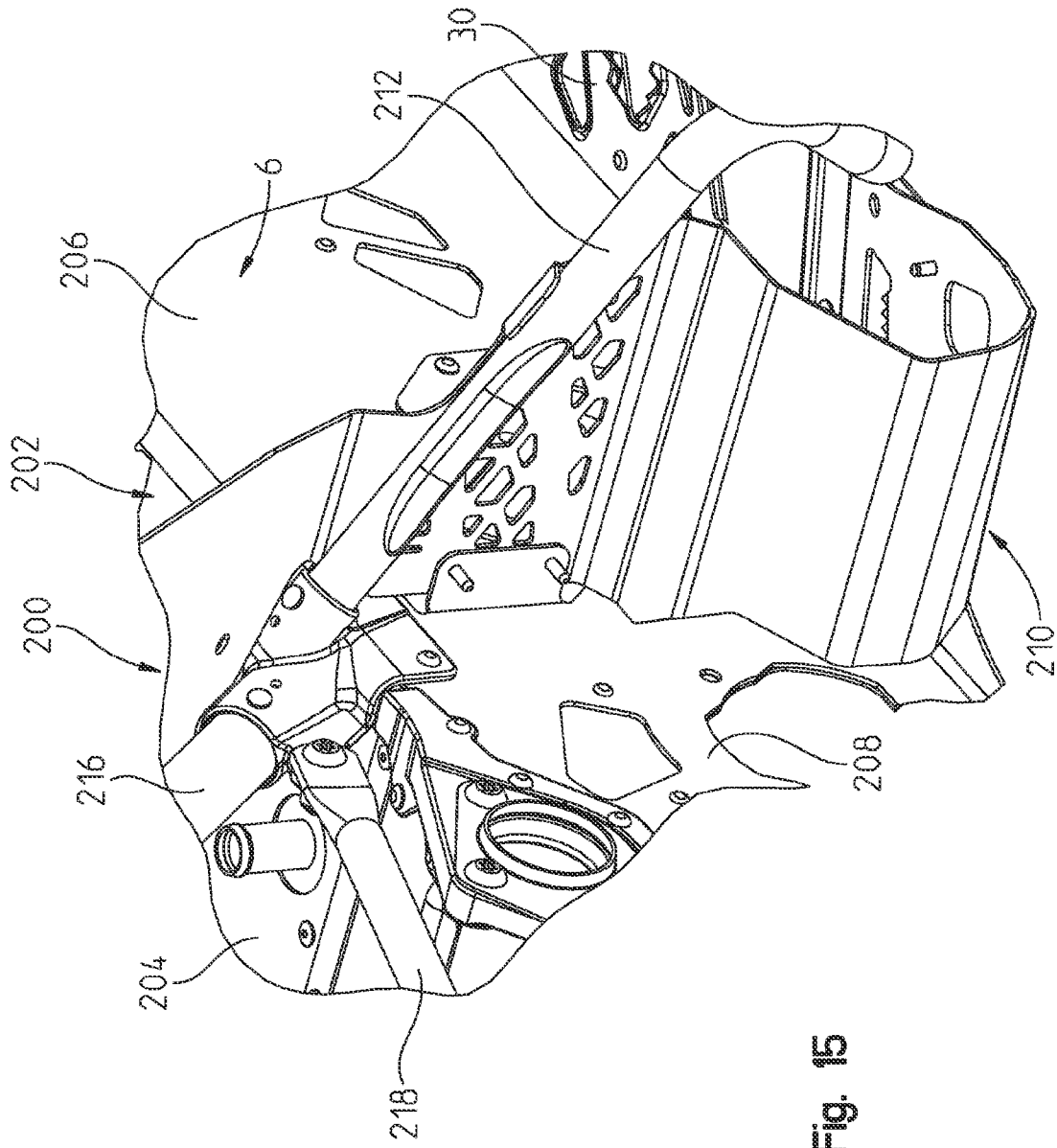

Fig. 15

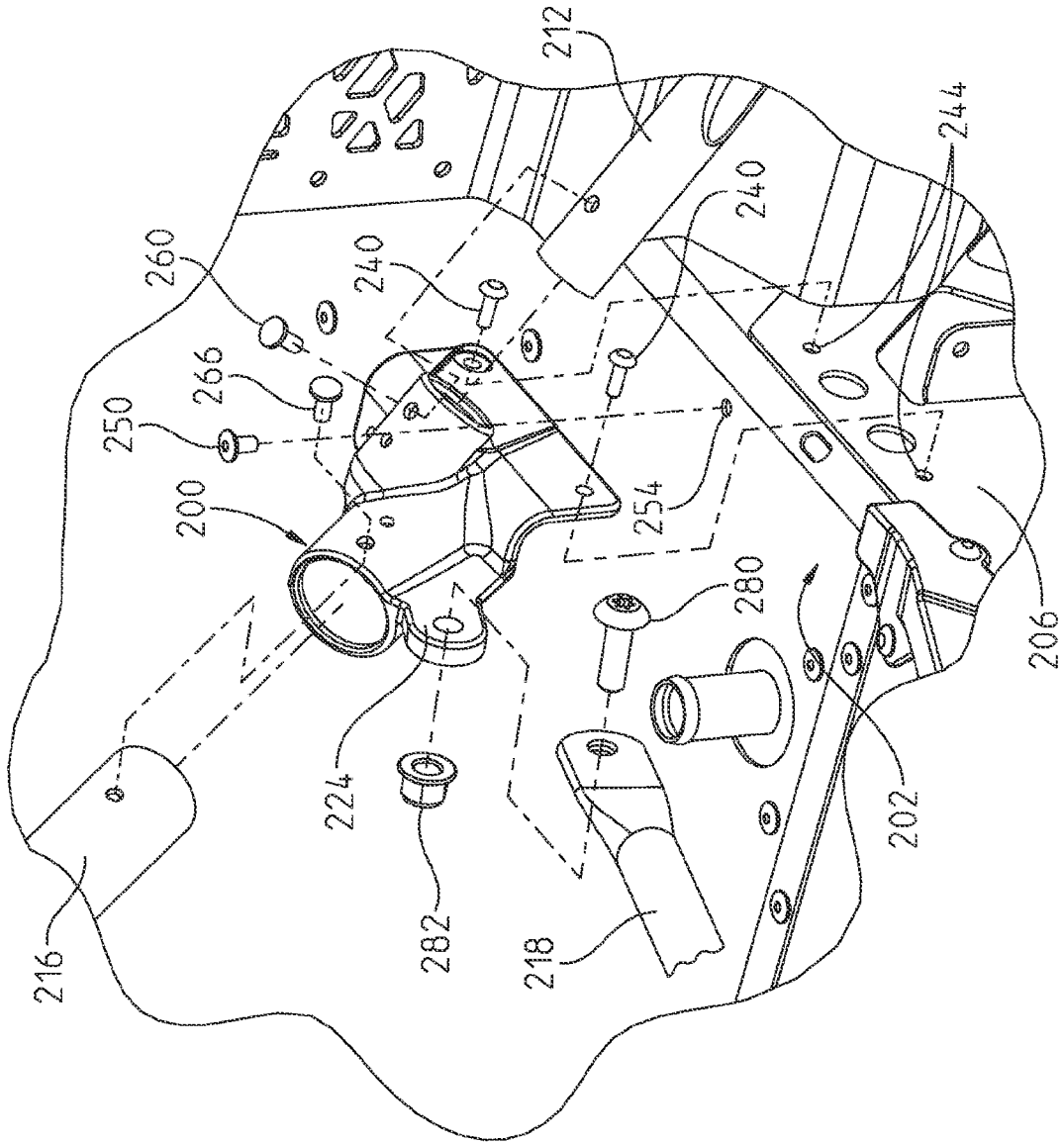

Fig. 16

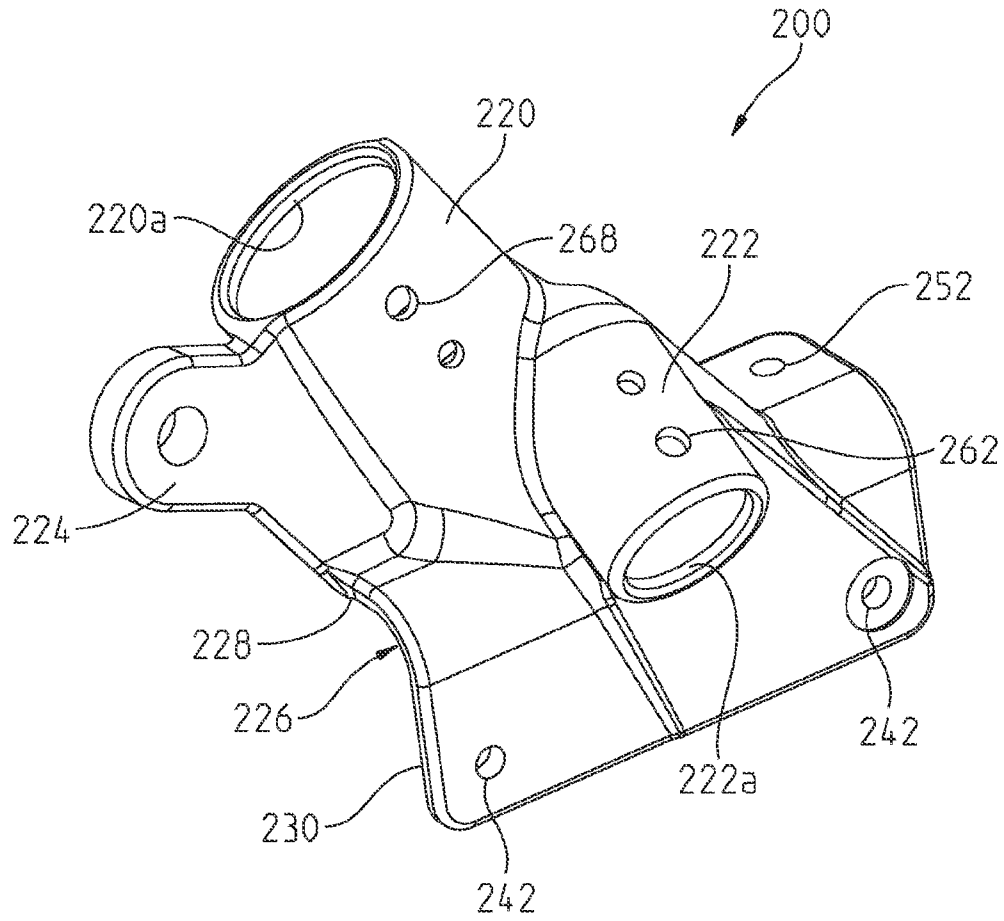

Fig. 17

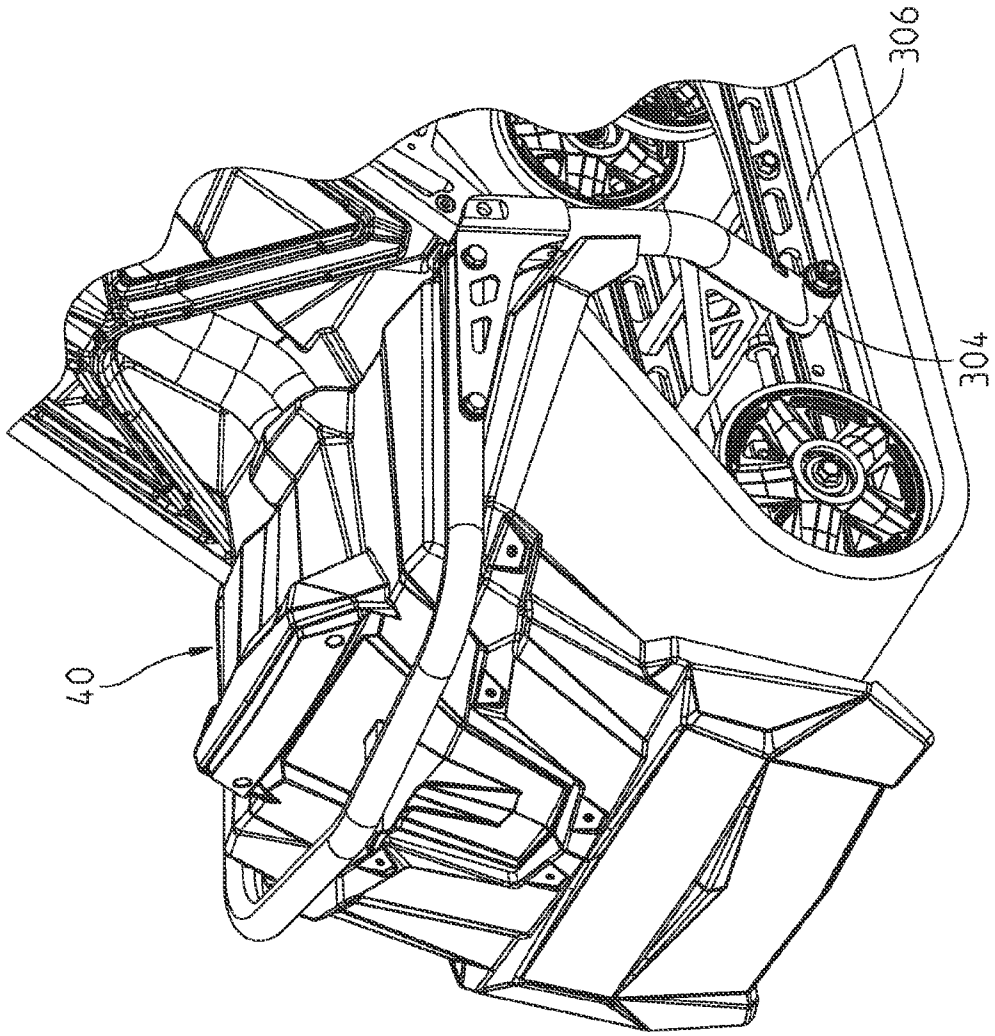

Fig. 18

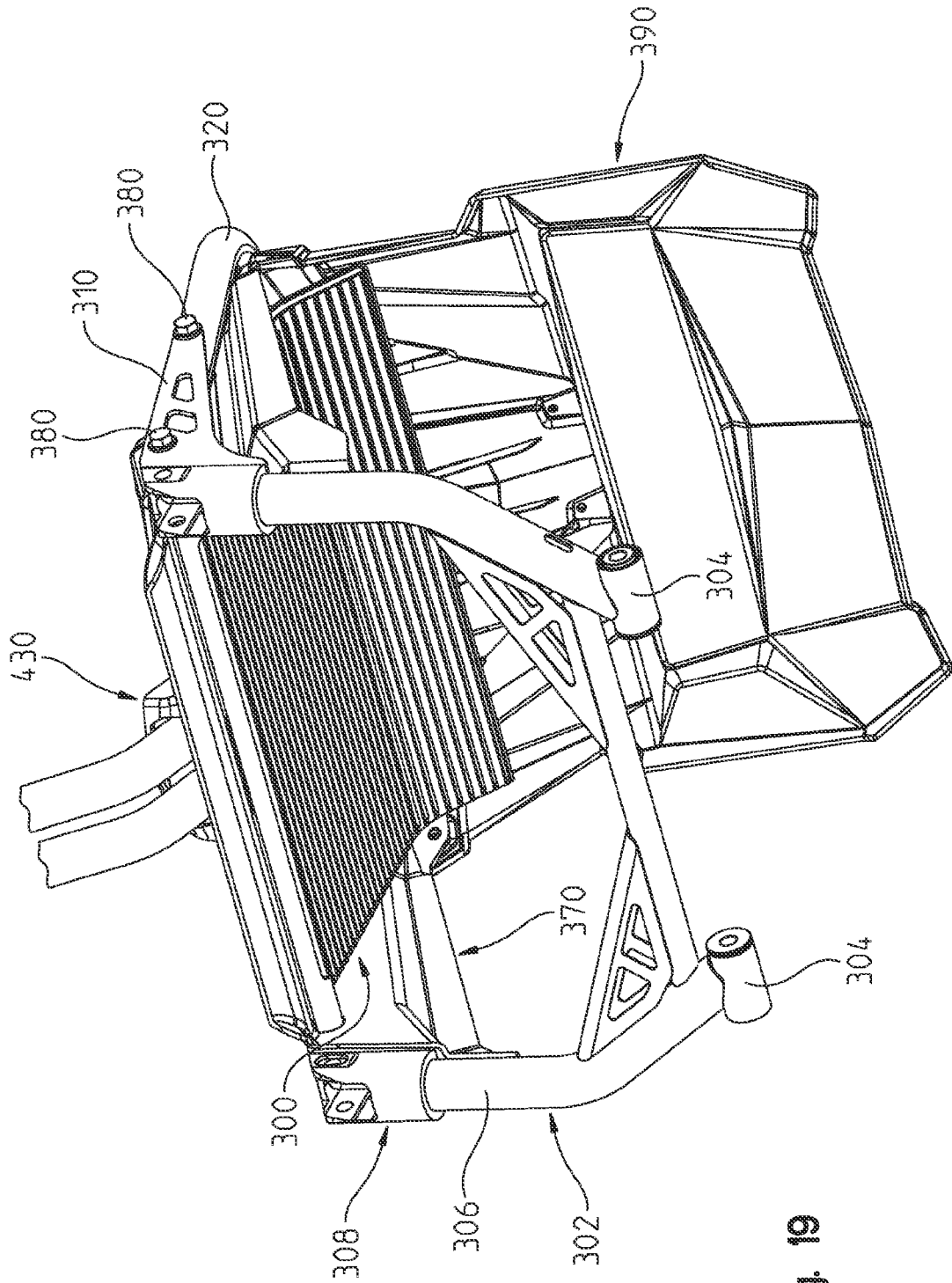

Fig. 19

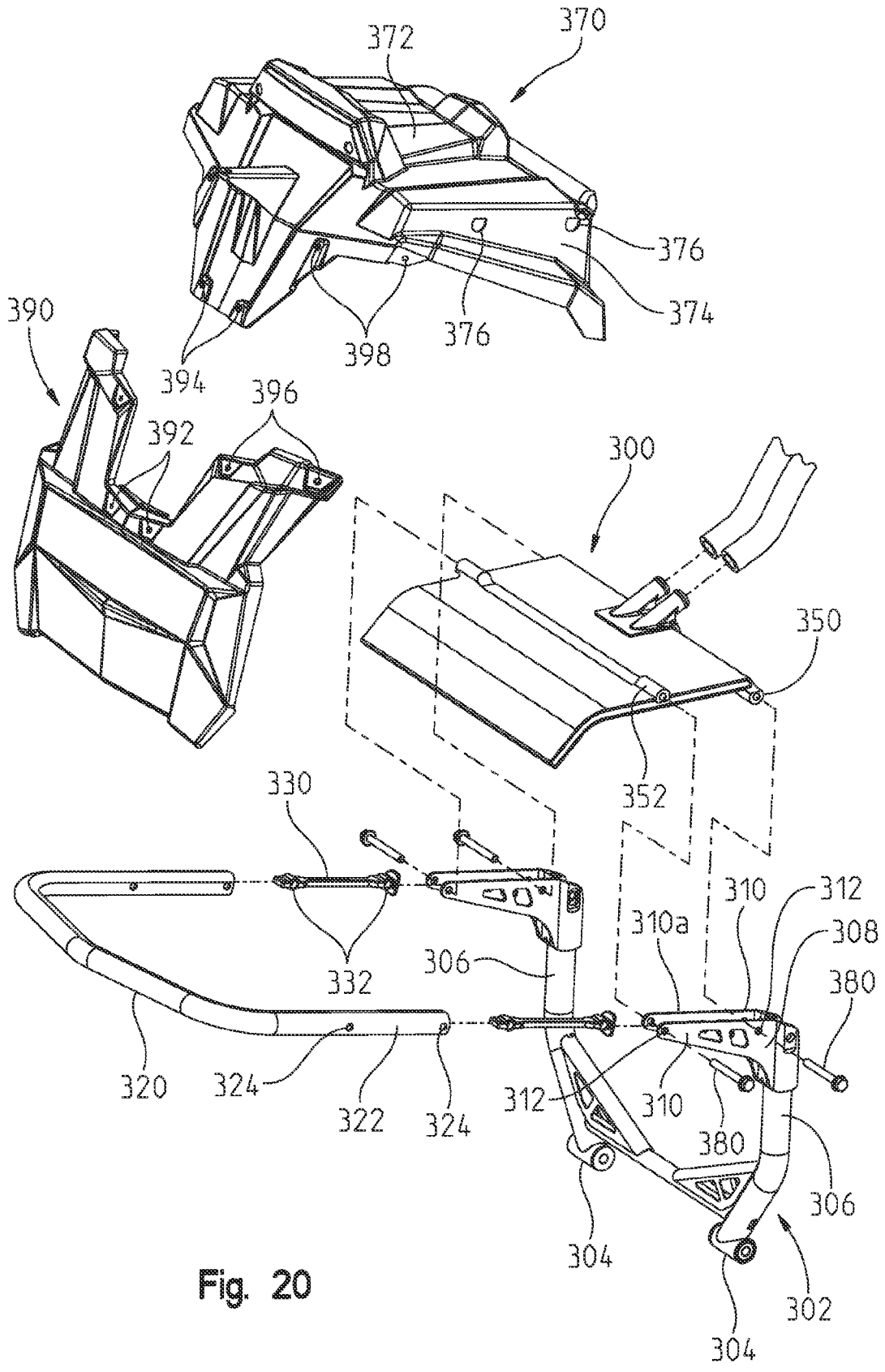

Fig. 20

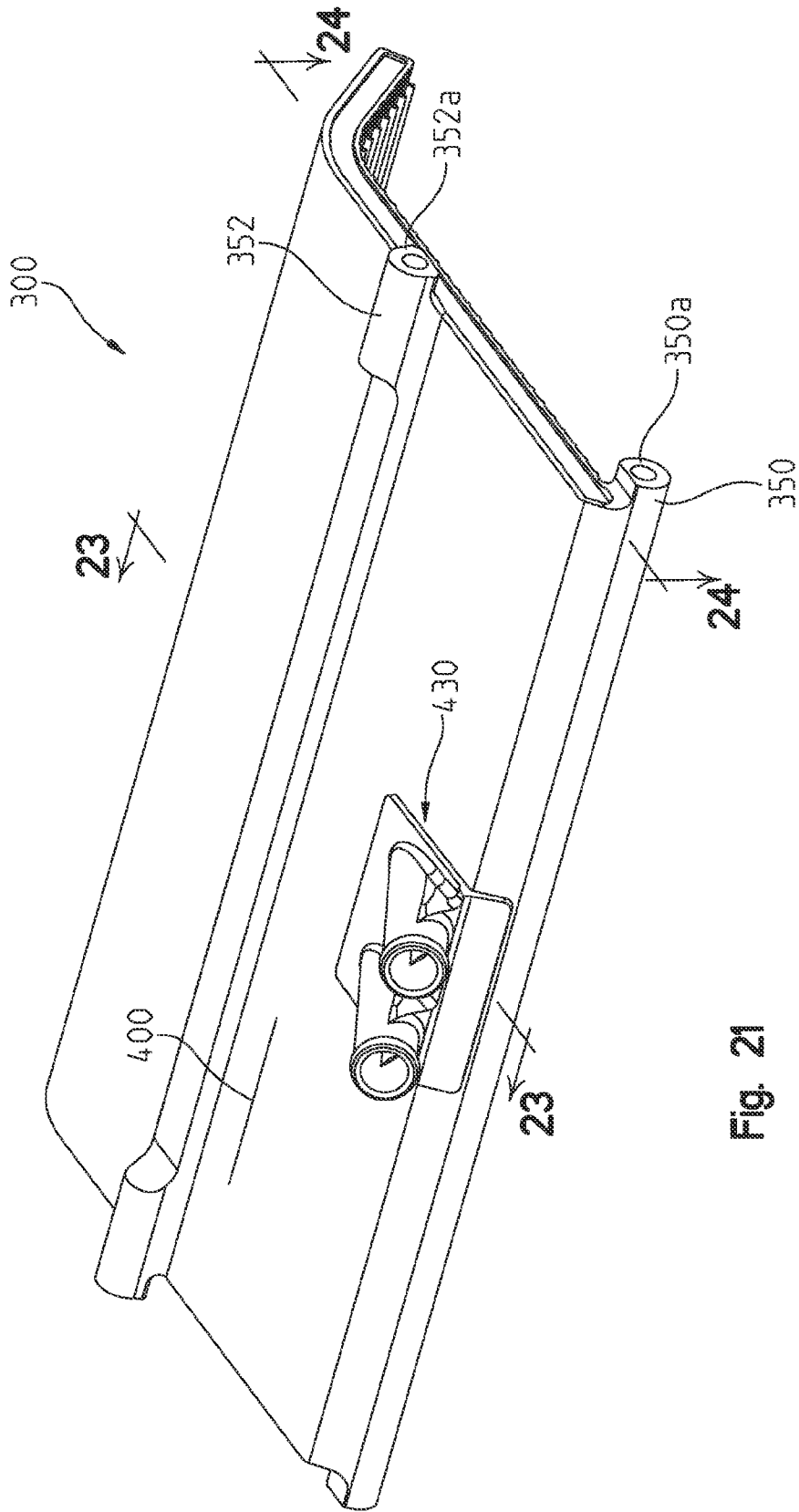

Fig. 21

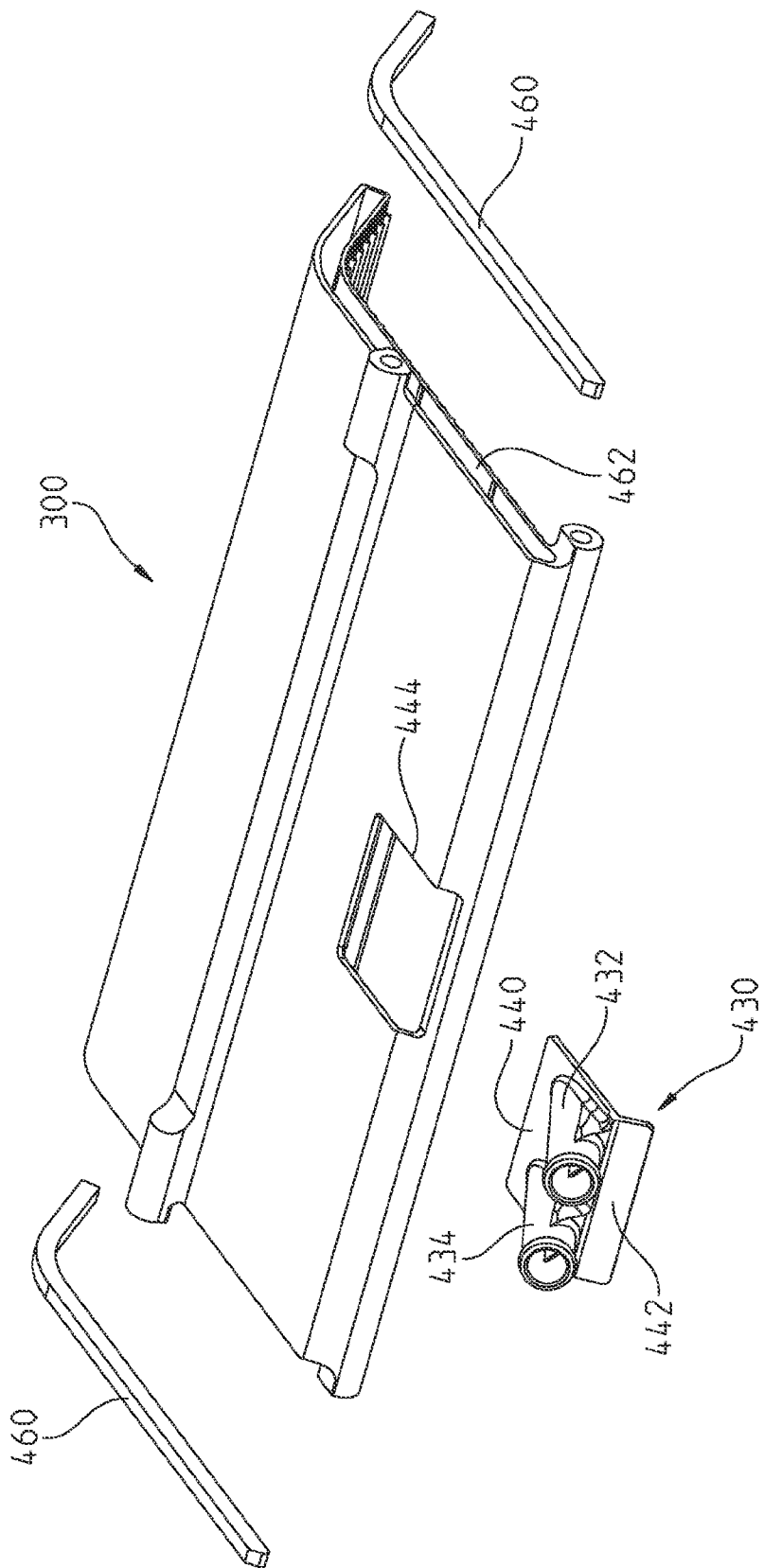

Fig. 22

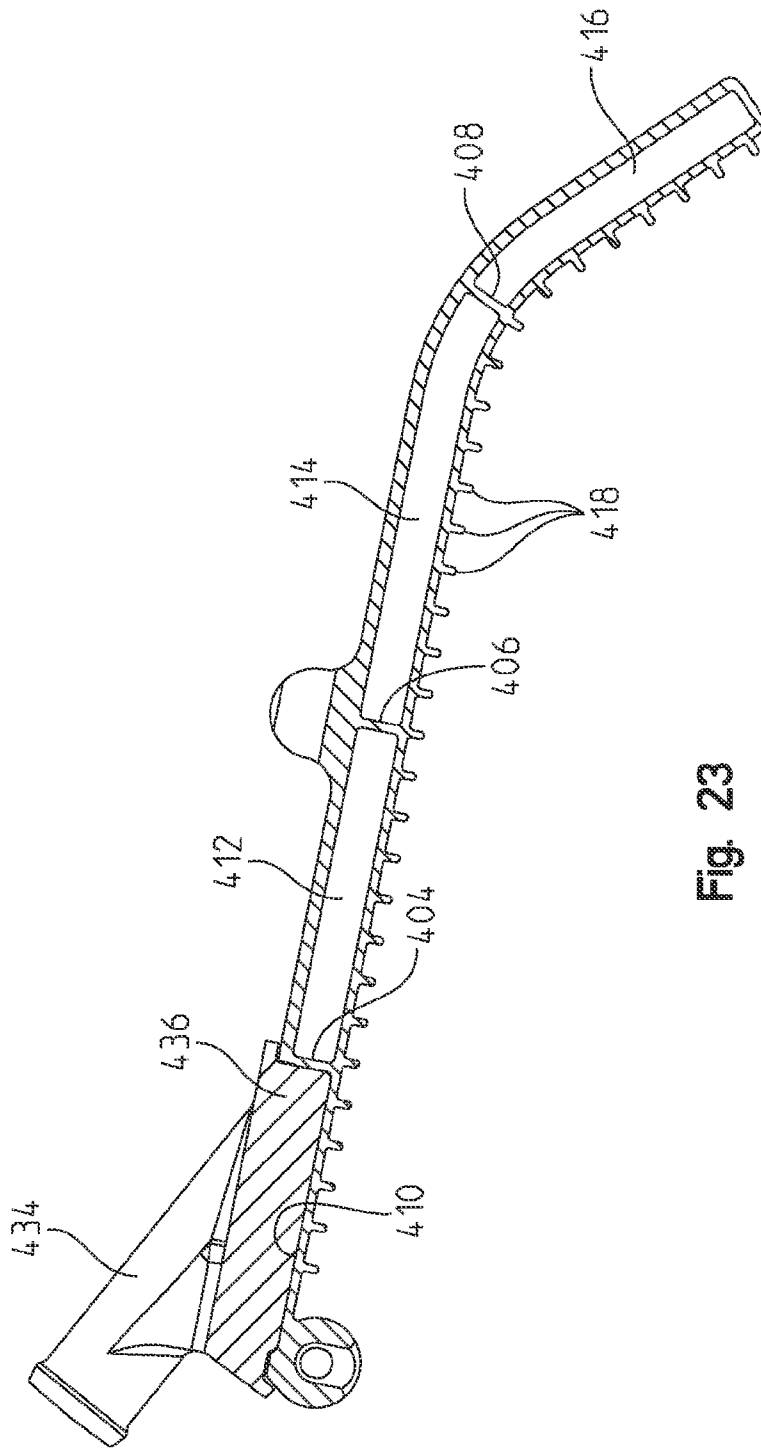

Fig. 23

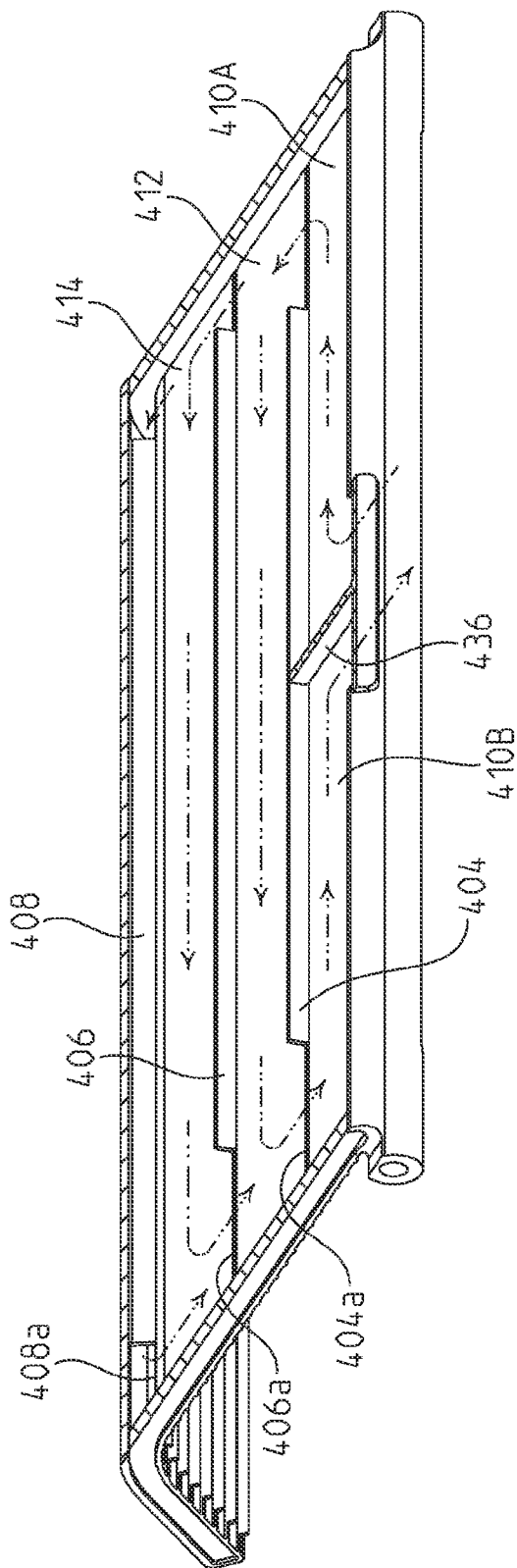

Fig. 24

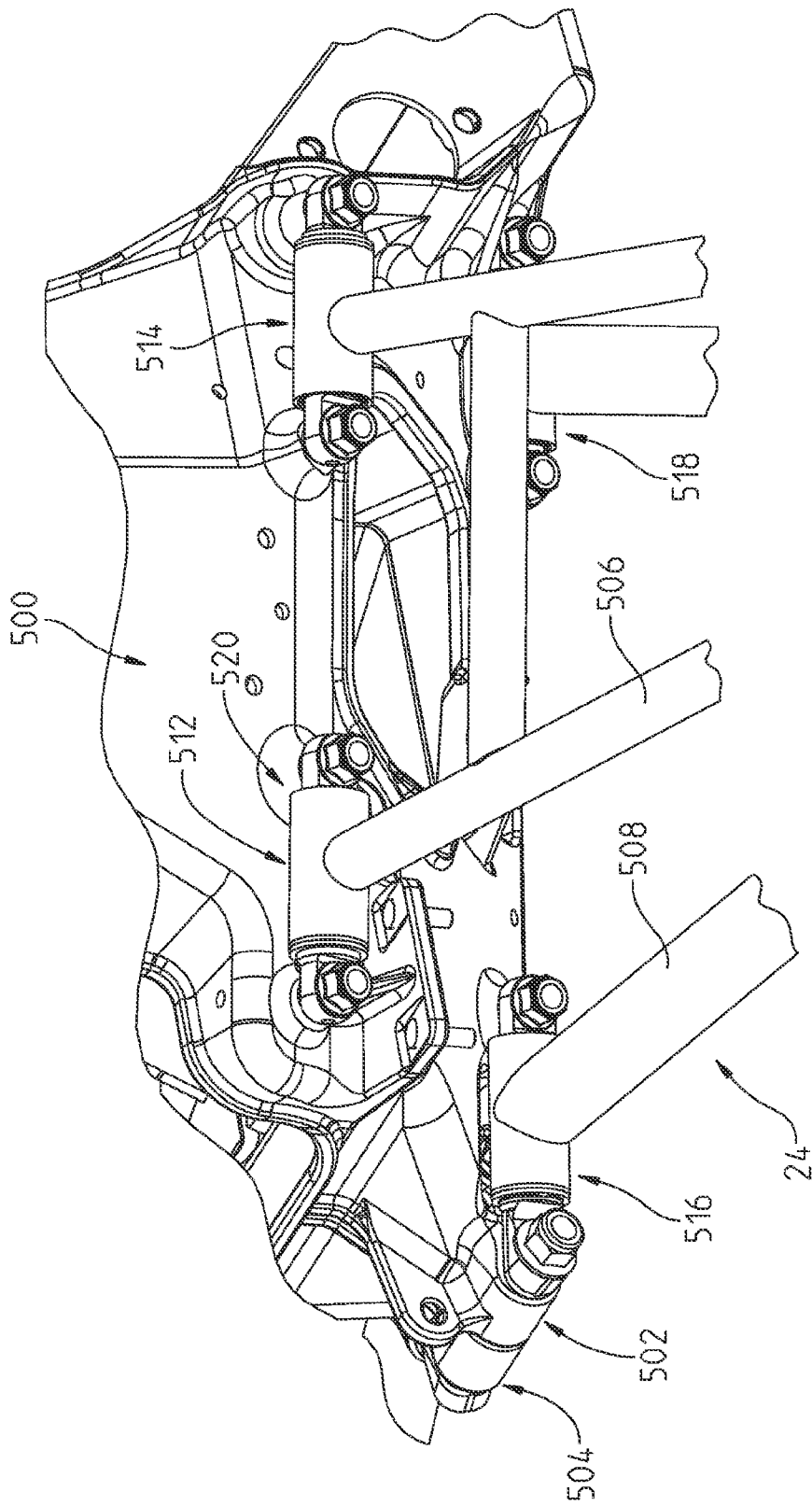

Fig. 25

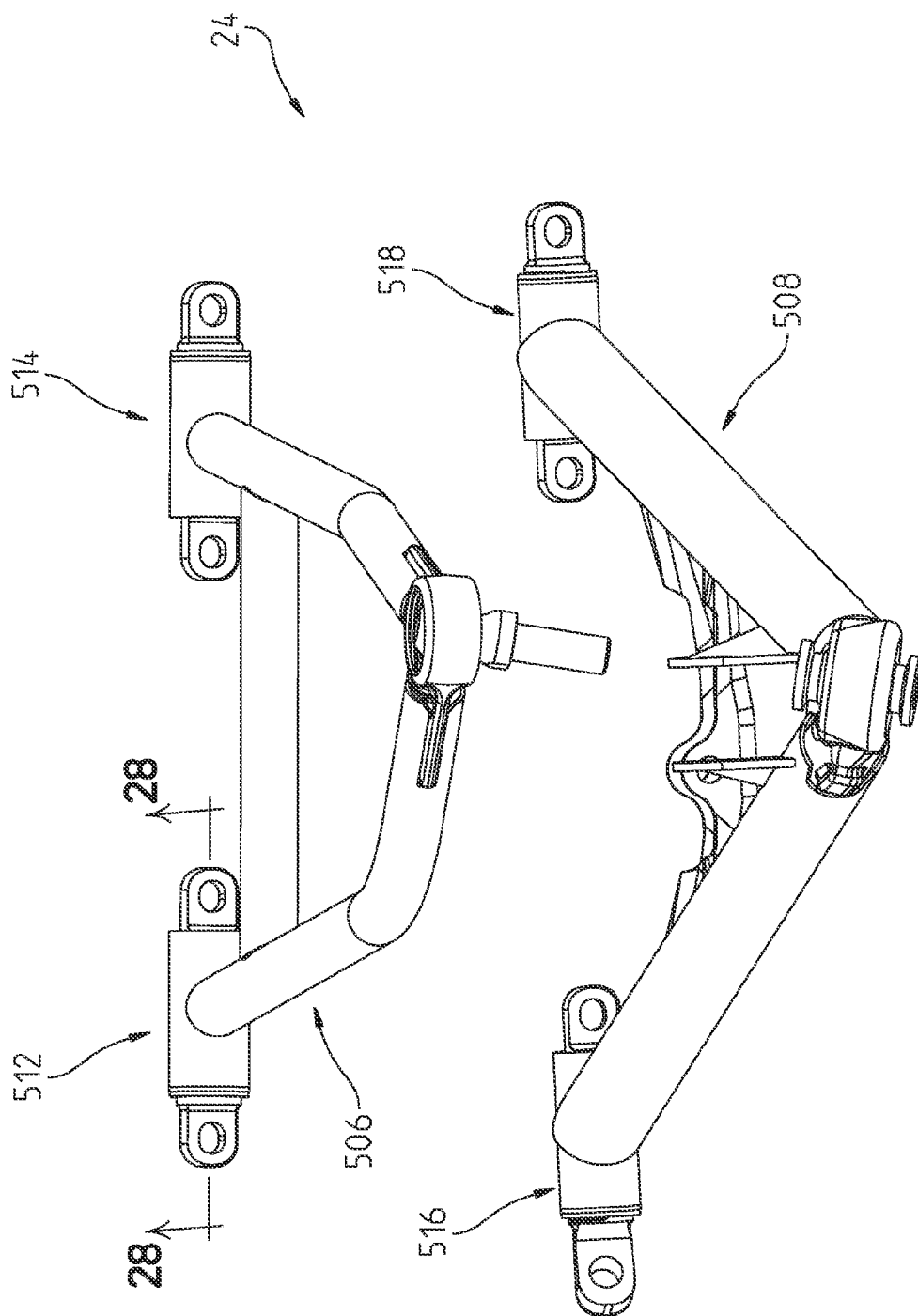

Fig. 26

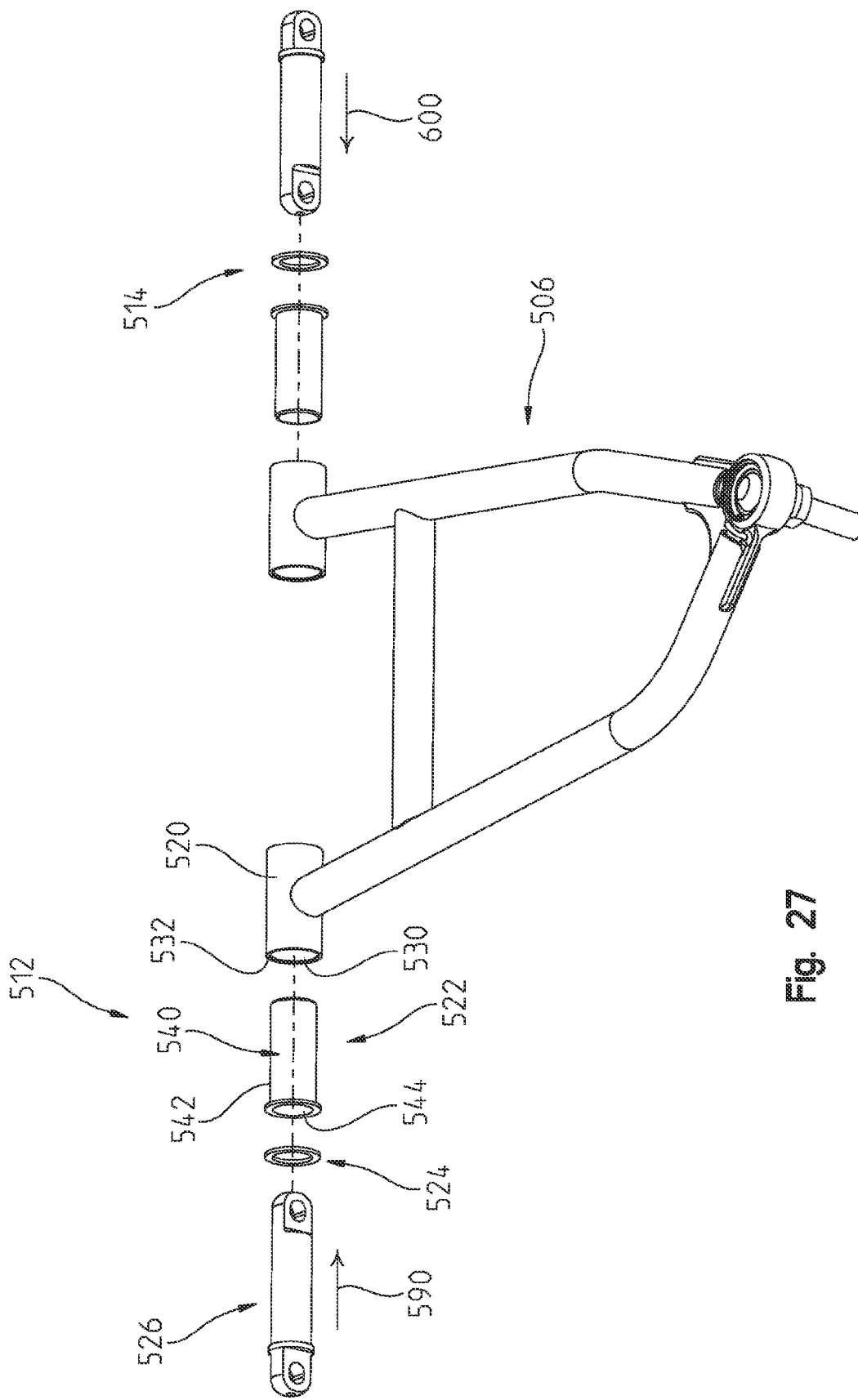

Fig. 27

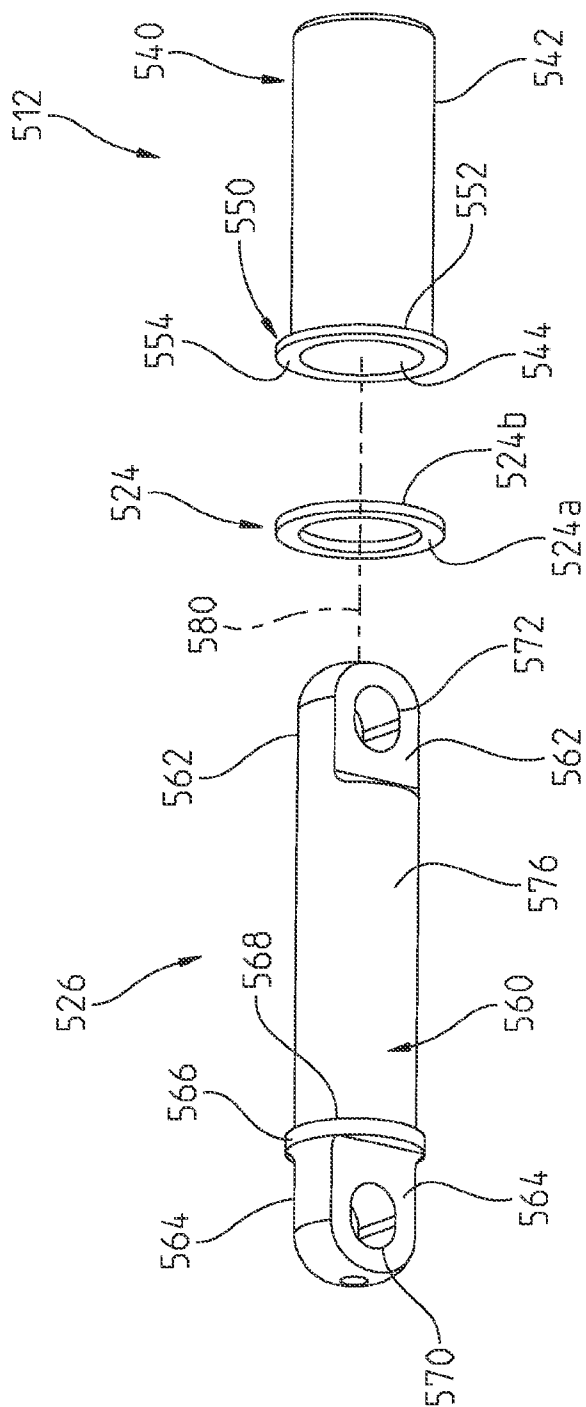

Fig. 27A

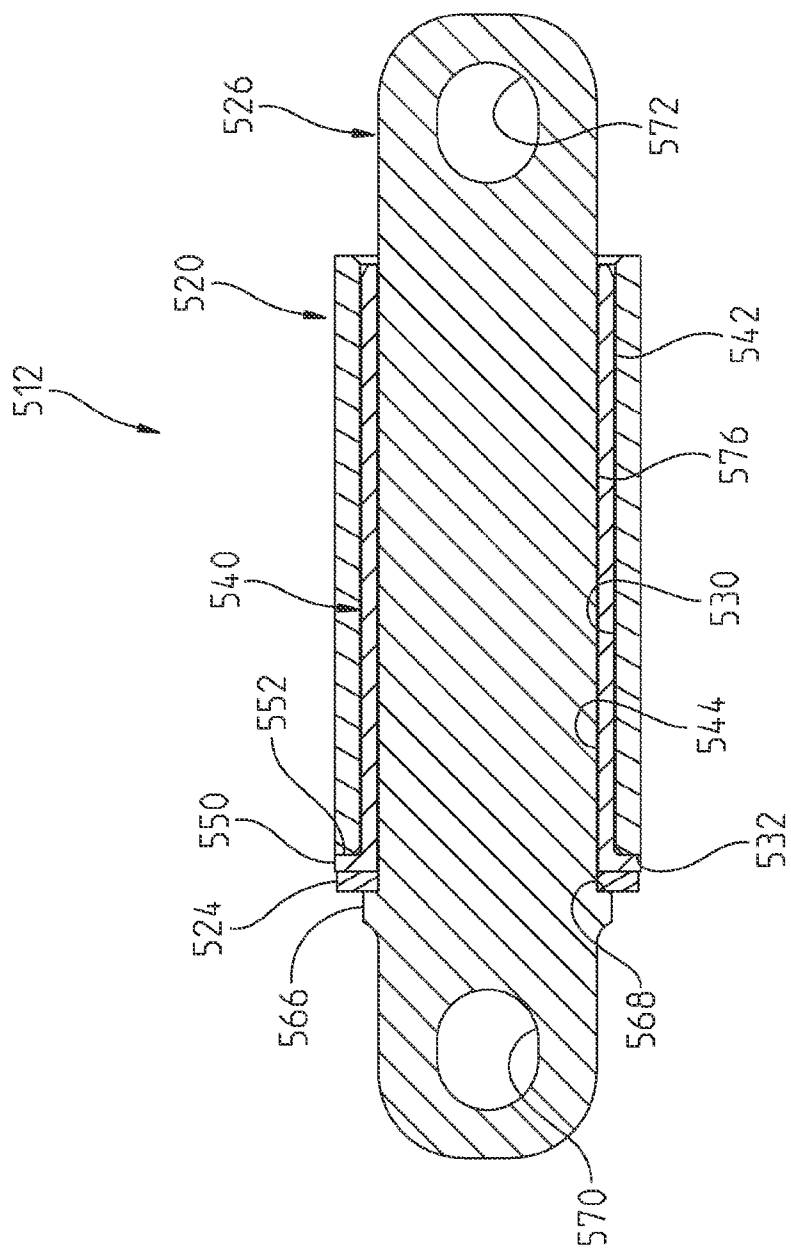

Fig. 28

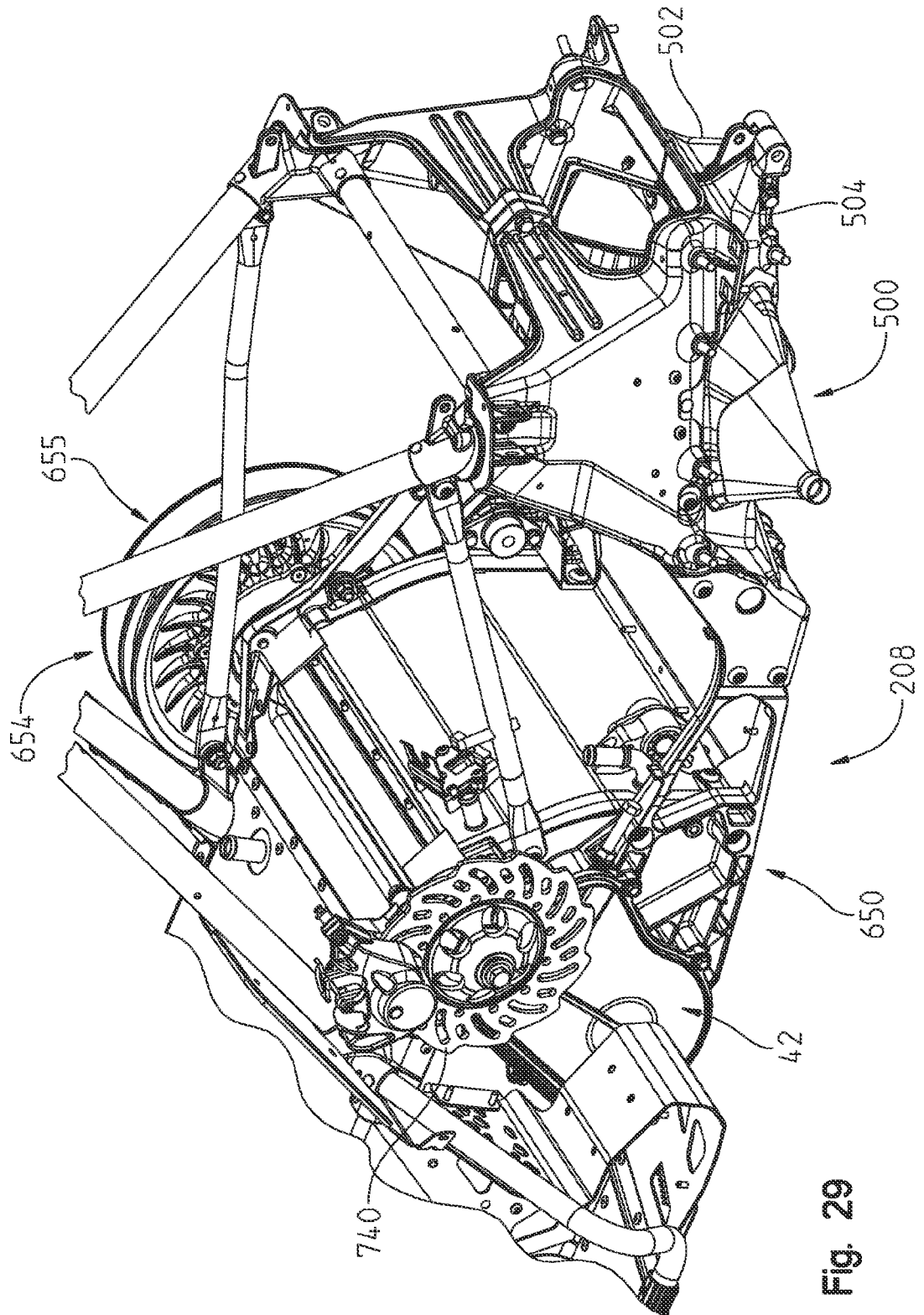

Fig. 29

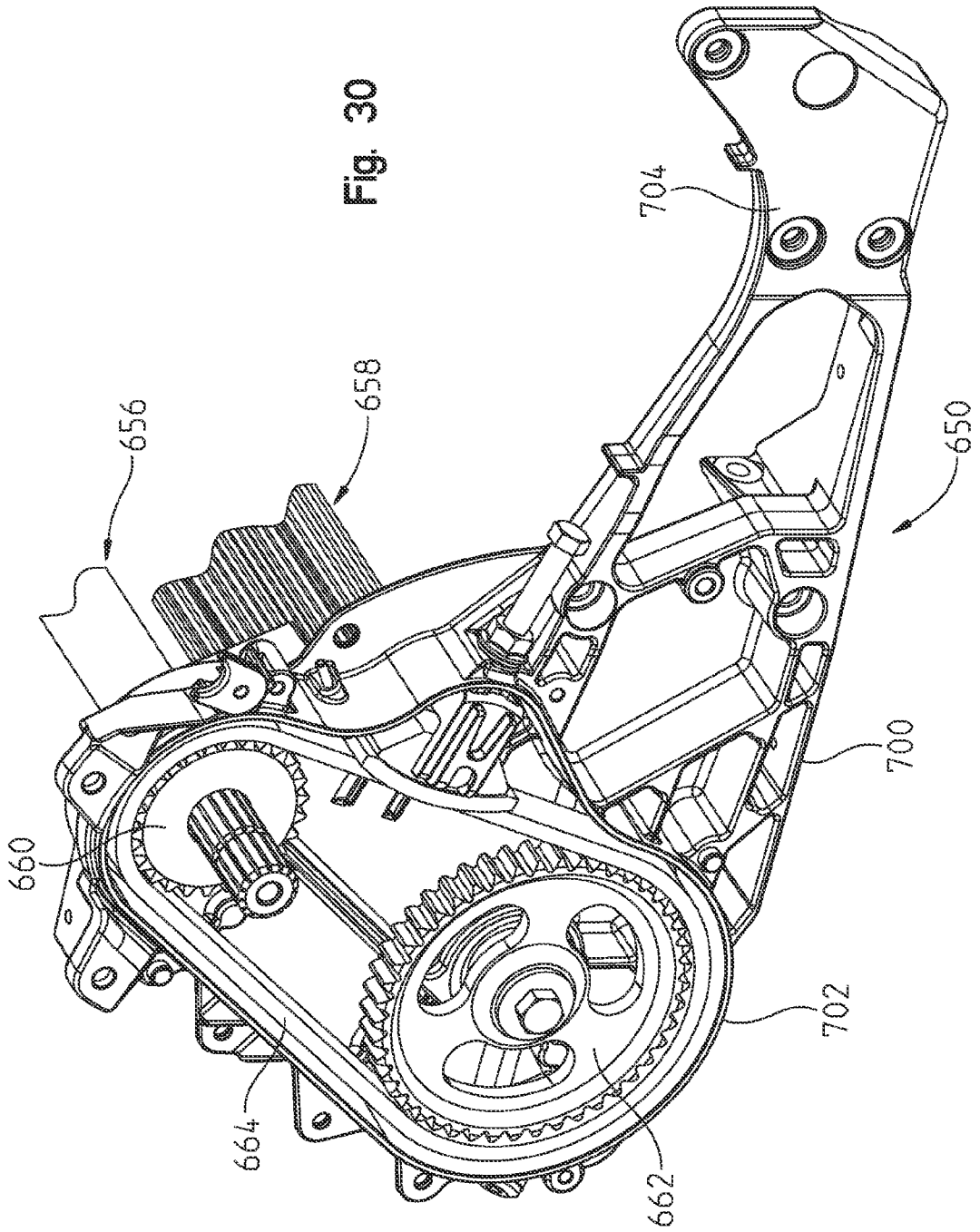

Fig. 30

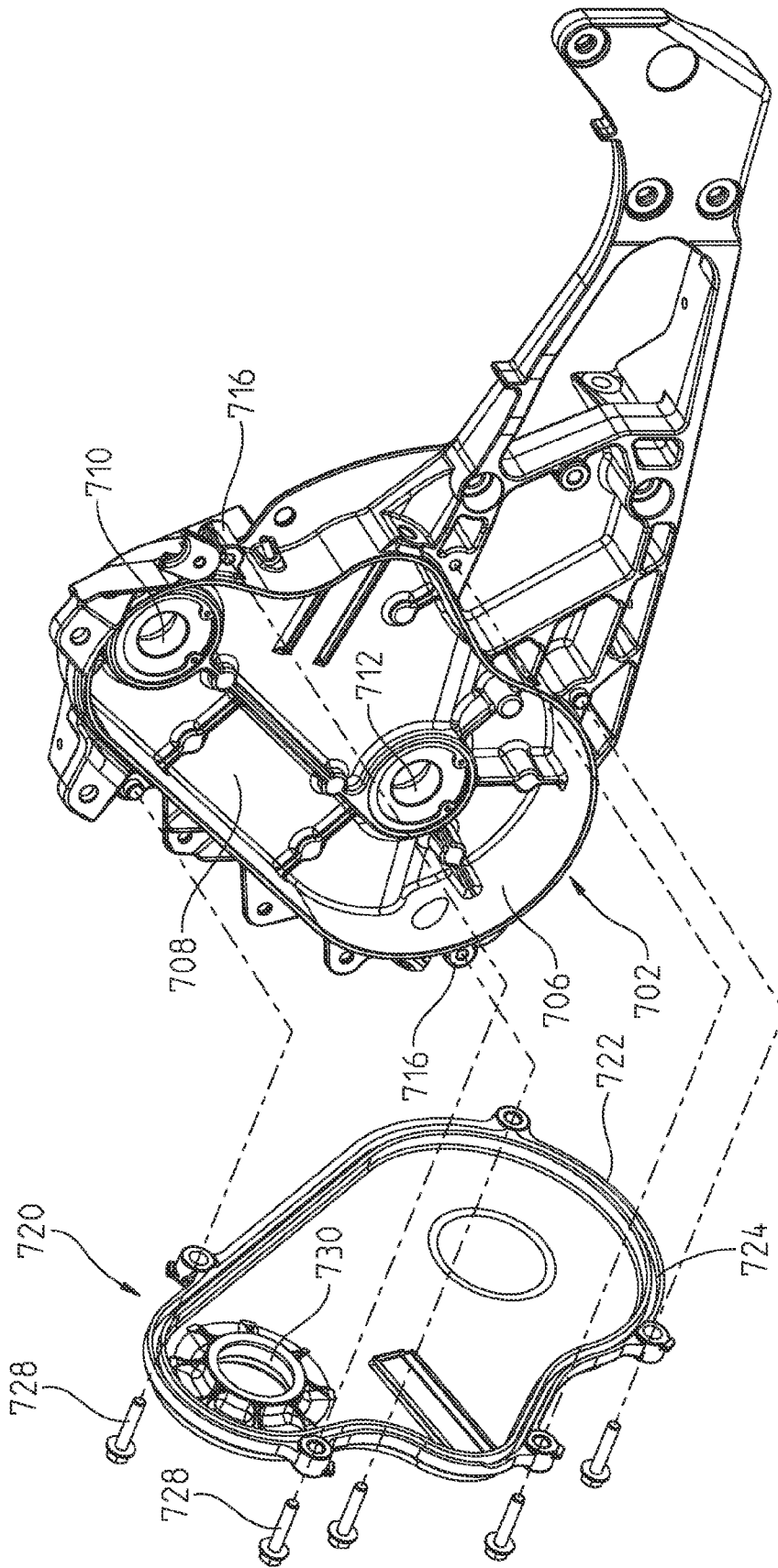

Fig. 31

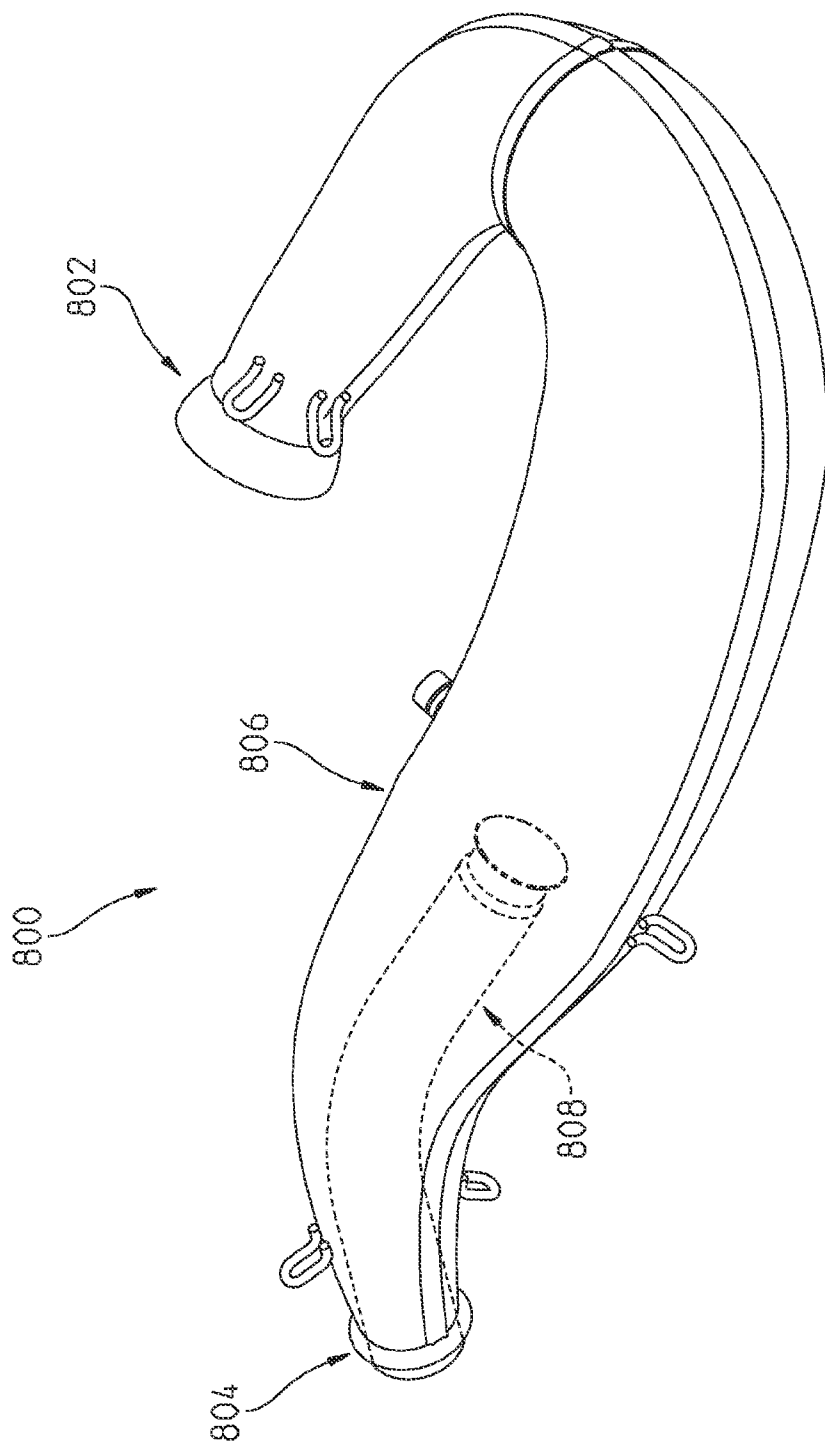

Fig. 32

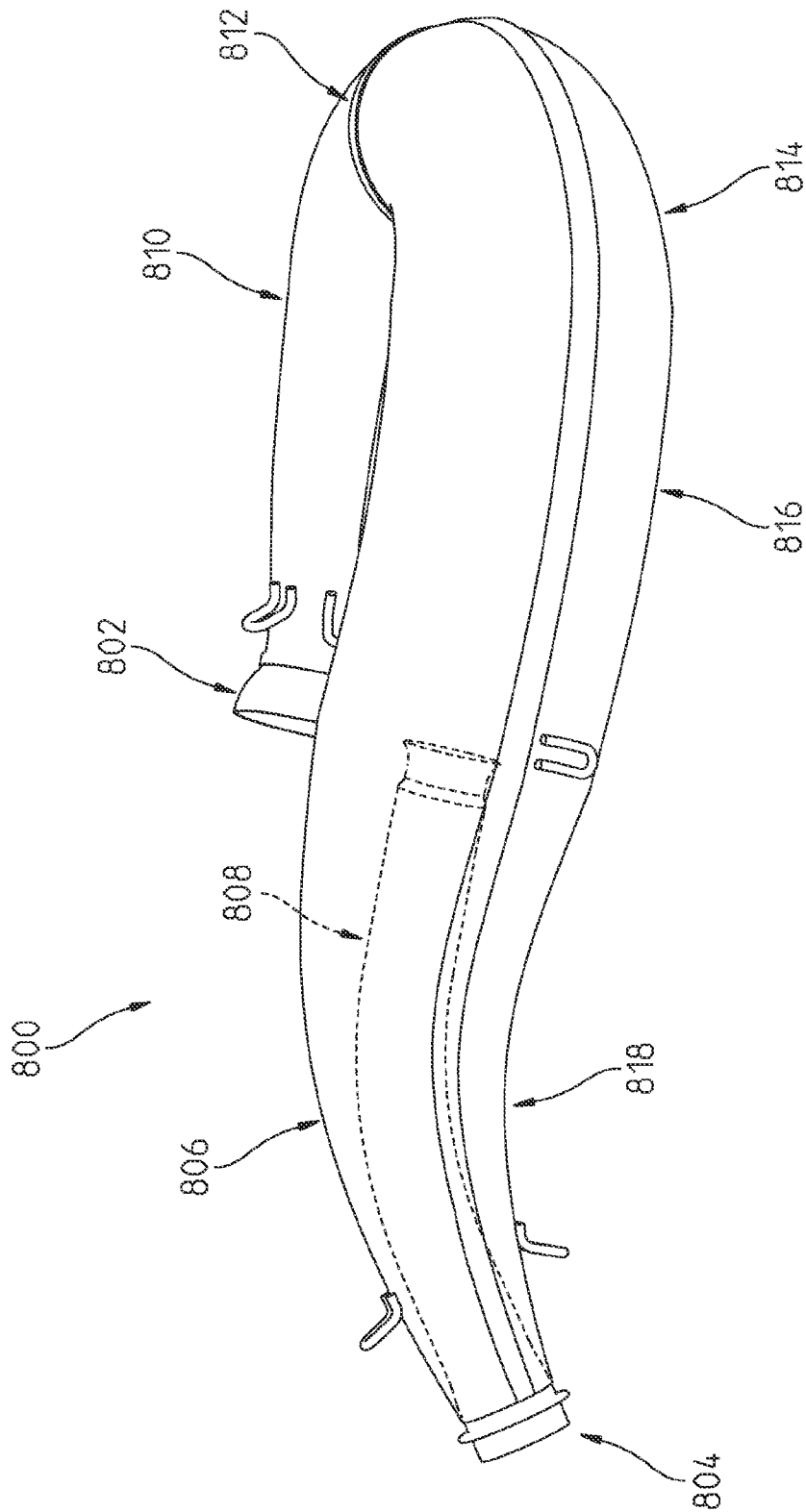

Fig. 33

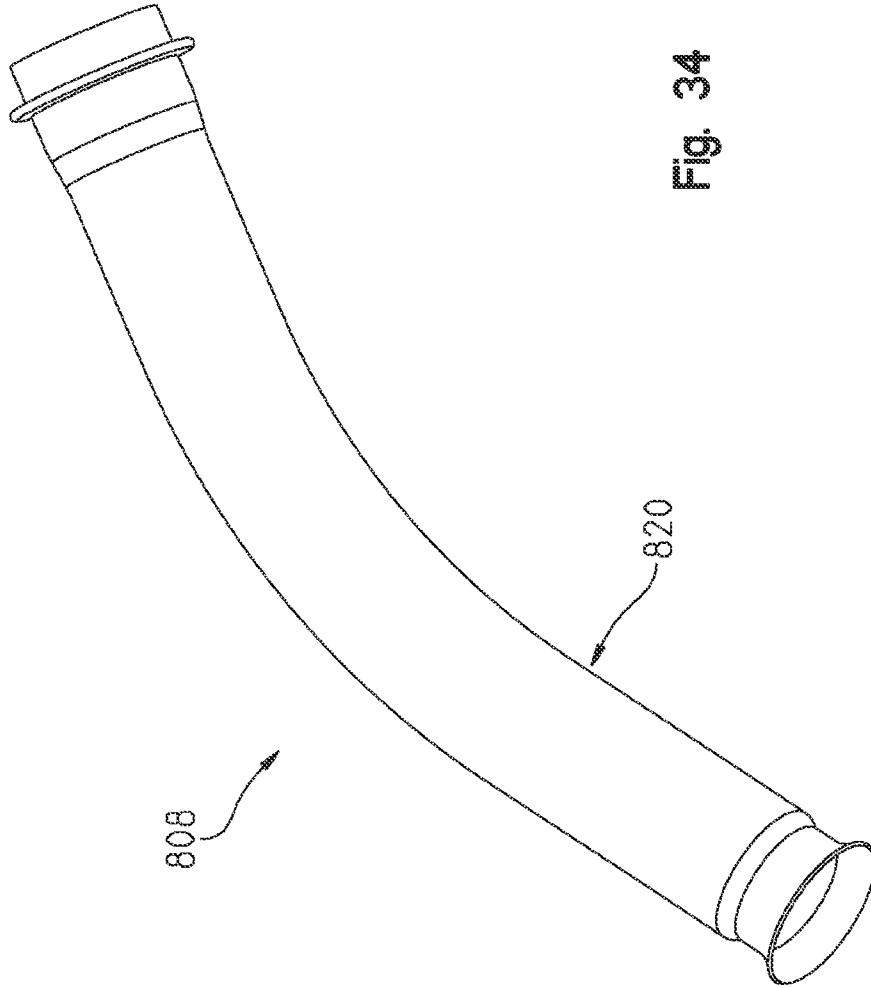

Fig. 34

