



US010392079B2

(12) **United States Patent**
Vezina et al.

(10) **Patent No.:** **US 10,392,079 B2**

(45) **Date of Patent:** **Aug. 27, 2019**

(54) **SNOWMOBILE FRAME STRUCTURE**

(56) **References Cited**

(71) Applicant: **BOMBARDIER RECREATIONAL PRODUCTS INC.**, Valcourt (CA)

U.S. PATENT DOCUMENTS

(72) Inventors: **Sebastien Vezina**, Sherbrooke (CA);
Yvon Bedard, Orford (CA)

6,942,051 B2 * 9/2005 Mallette B62J 35/00
180/183

7,543,669 B2 * 6/2009 Kelahaara B62M 27/02
180/190

(73) Assignee: **BOMBARDIER RECREATIONAL PRODUCTS INC.**, Valcourt (CA)

D723,976 S 3/2015 Petit et al.
2005/0205320 A1 * 9/2005 Girouard B62J 35/00
180/190

(*) Notice: Subject to any disclaimer, the term of this patent is extended or adjusted under 35 U.S.C. 154(b) by 483 days.

2006/0162976 A1 * 7/2006 Desmarais B62M 27/02
180/190

OTHER PUBLICATIONS

(21) Appl. No.: **14/788,612**

BRP Finland OY, Lynx—The Heroes of Lynx, Lynx Lineup Brochure, 2012, Cover page, page 8 and last page, Finland.

(22) Filed: **Jun. 30, 2015**

(Continued)

(65) **Prior Publication Data**

Primary Examiner — Jacob D Knutson

US 2016/0200397 A1 Jul. 14, 2016

(74) *Attorney, Agent, or Firm* — BCF LLP

Related U.S. Application Data

(57) **ABSTRACT**

(60) Provisional application No. 62/019,259, filed on Jun. 30, 2014.

A snowmobile has a frame, a front and a rear suspension assembly connected thereto, at least one ski, an endless drive track, and a motor. The frame includes a longitudinally extending tunnel, the rear suspension assembly being connected thereto. The tunnel includes a top wall extending generally horizontally and comprising a left edge and a right edge. A planar left bevel wall extends downwardly and leftwardly from the left edge. A left side wall extends downwardly from the left bevel wall. A planar right bevel wall extends downwardly and rightwardly from the right edge. A right side wall extends downwardly from the right bevel wall. An upper rear support includes a left leg and a right leg, each having a lower end connected to the corresponding one of the left bevel wall and the right bevel wall and extending forwardly, upwardly and laterally inwardly therefrom to an upper end.

(51) **Int. Cl.**
B62M 27/02 (2006.01)

(52) **U.S. Cl.**
CPC **B62M 27/02** (2013.01); **B62M 2027/023** (2013.01); **B62M 2027/025** (2013.01); **B62M 2027/026** (2013.01); **B62M 2027/028** (2013.01)

(58) **Field of Classification Search**
CPC B62M 27/02; B62M 2027/023; B62M 2027/025; B62M 2027/026
USPC 180/190
See application file for complete search history.

25 Claims, 30 Drawing Sheets

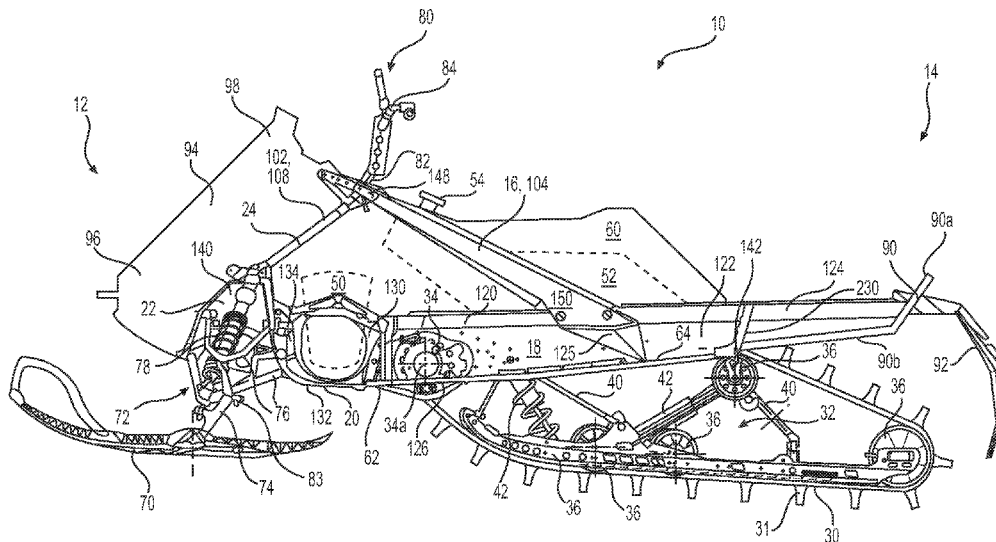

(56)

References Cited

OTHER PUBLICATIONS

BRP Finland OY, Lynx—Lynx Times, Lynx Brochure Spring 2014, 2014, Cover page, pp. 12, 13, 18, 19 and last page, Lynx Times Magazine, Finland.

Bombardier Recreational Products Inc., Linx—The Heroes of Lynx, Brochure, 2012, Finland.

Bombardier Recreational Products Inc., Linx 2013 Rave 550, Parts Catalog.

* cited by examiner

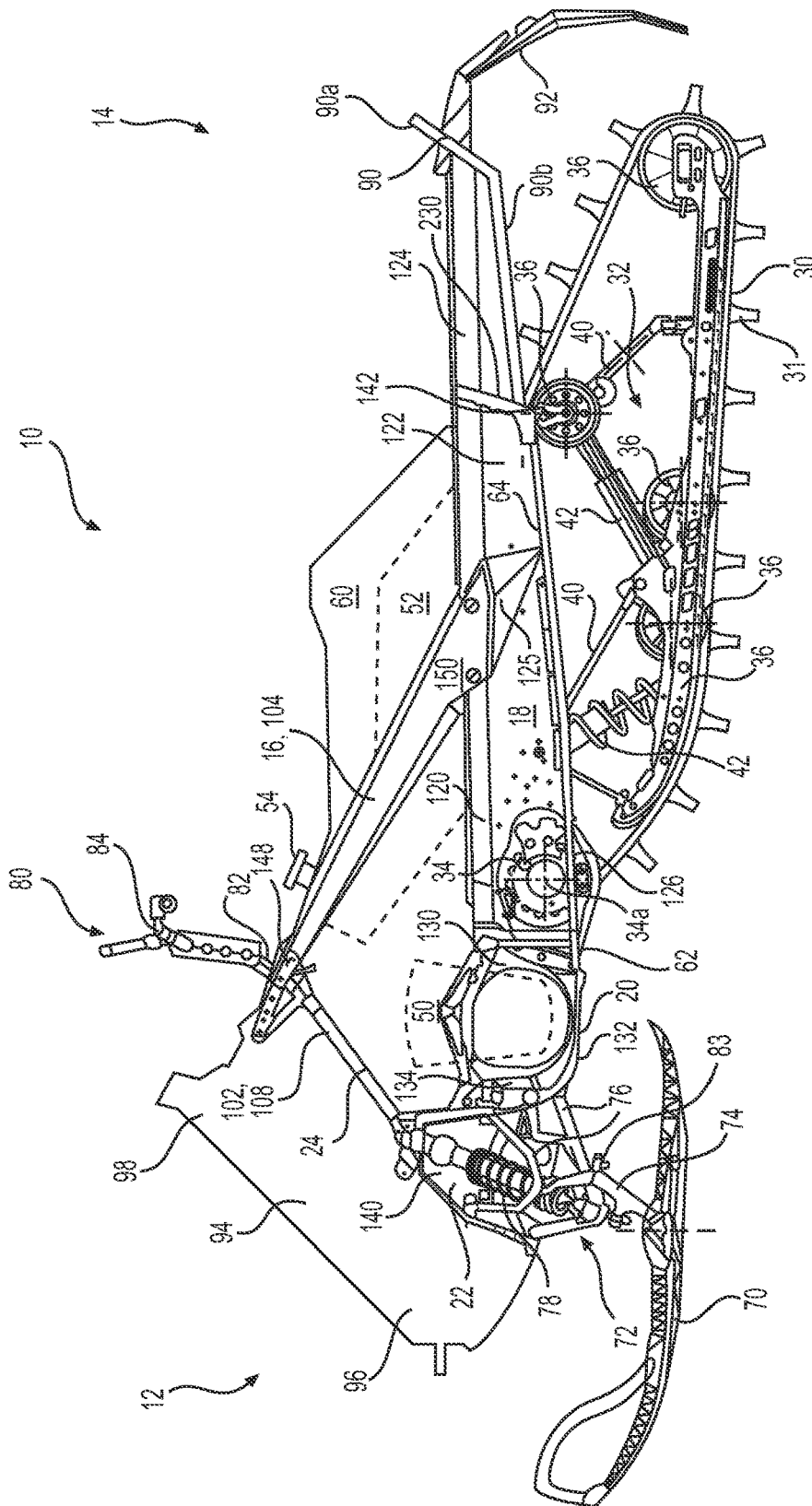

FIG. 1

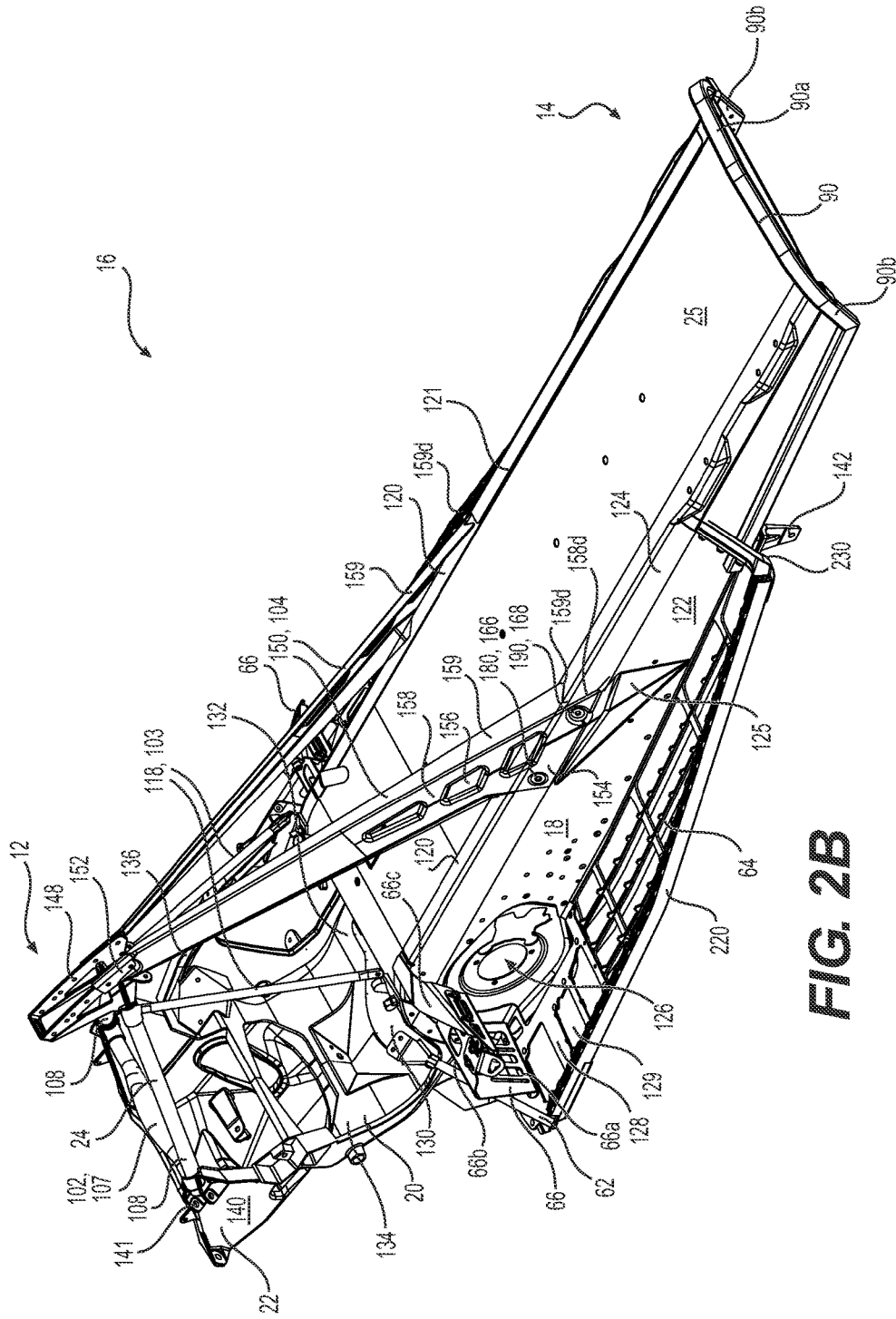

FIG. 2B

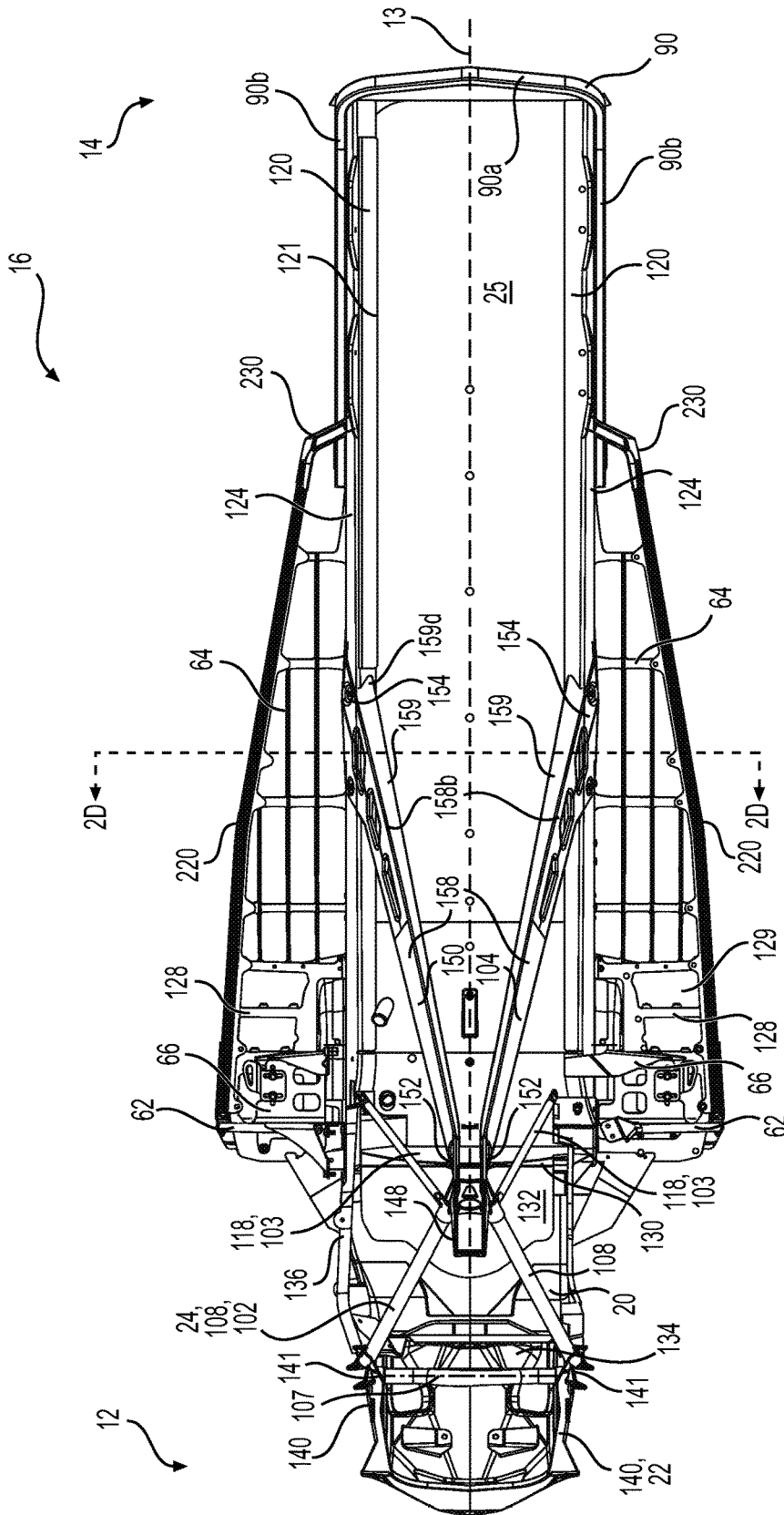

FIG. 2C

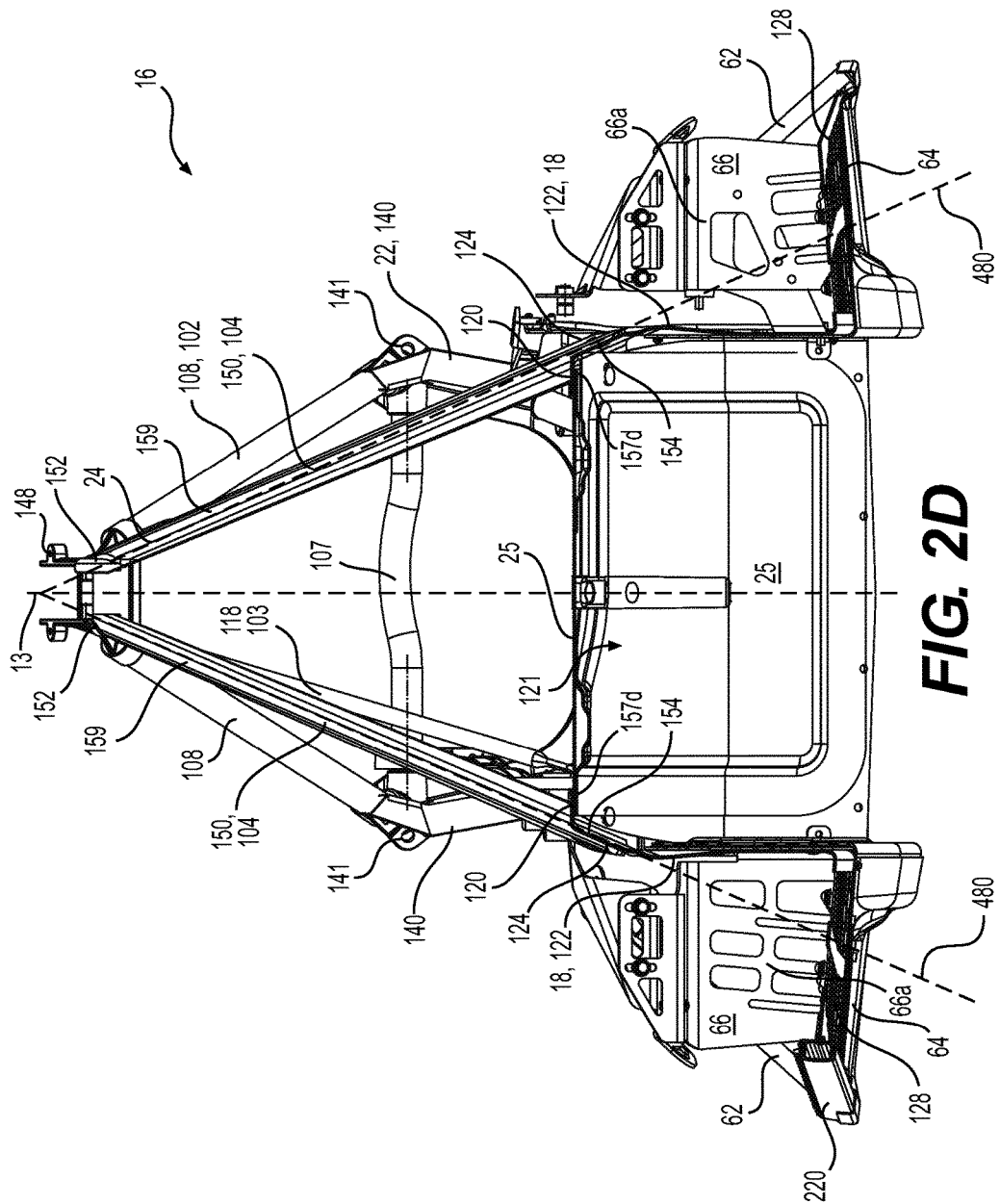

FIG. 2D

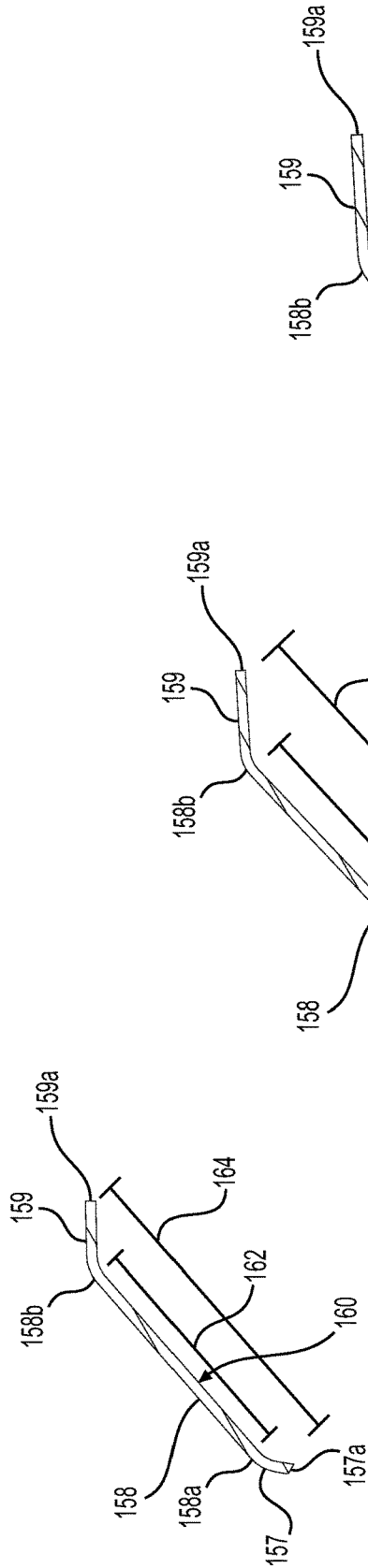

FIG. 4A

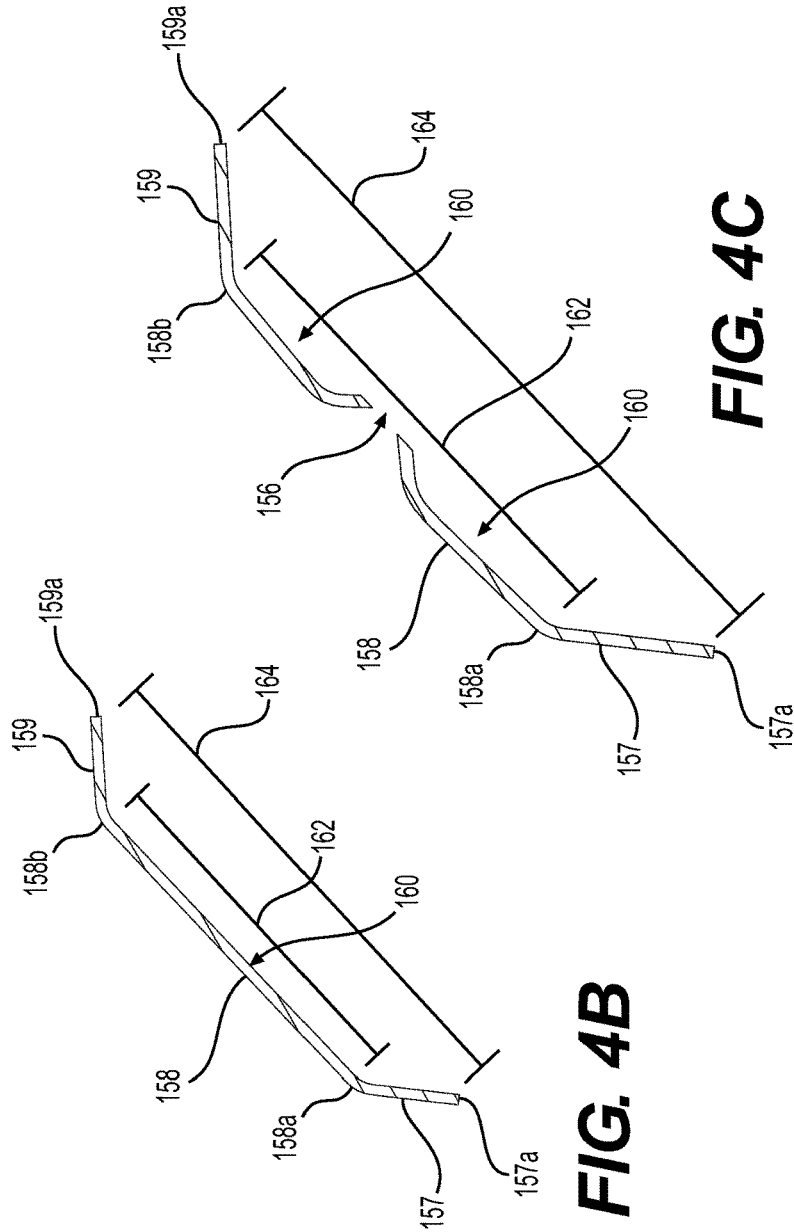

FIG. 4B

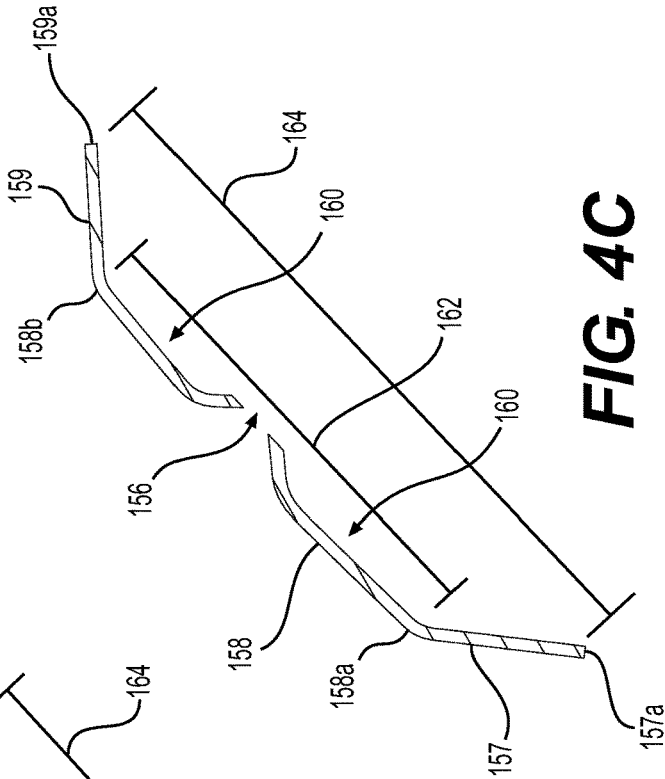

FIG. 4C

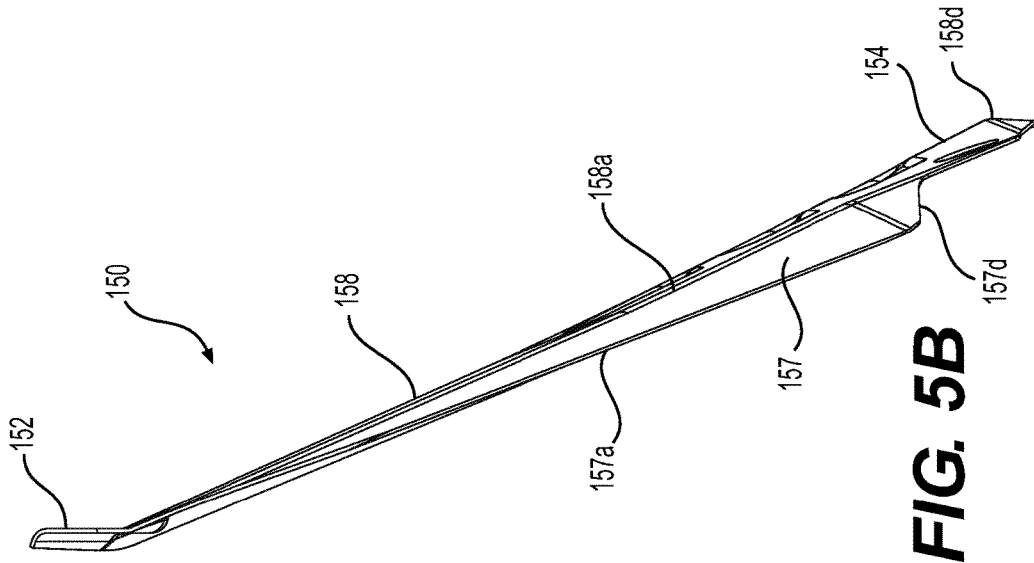

FIG. 5B

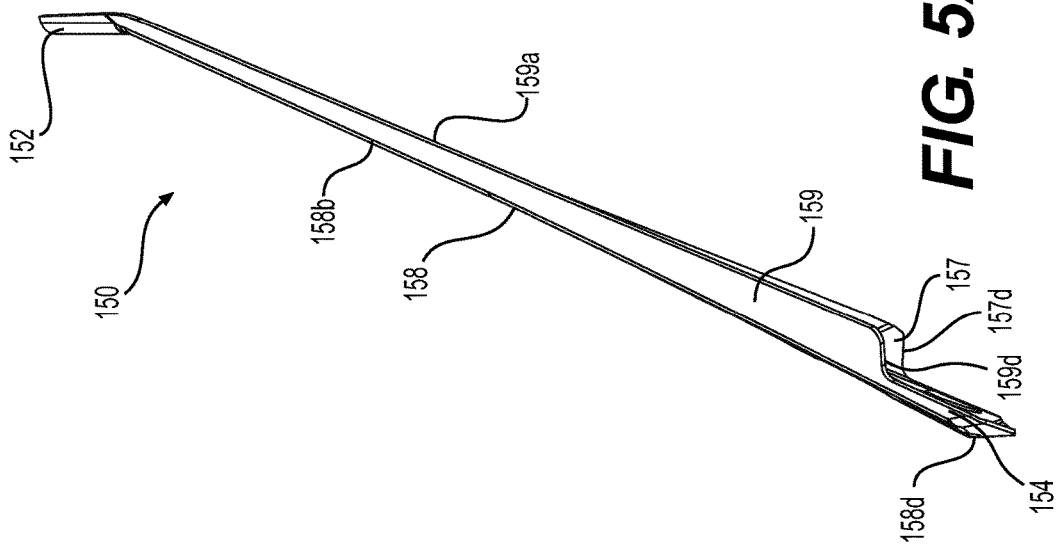

FIG. 5A

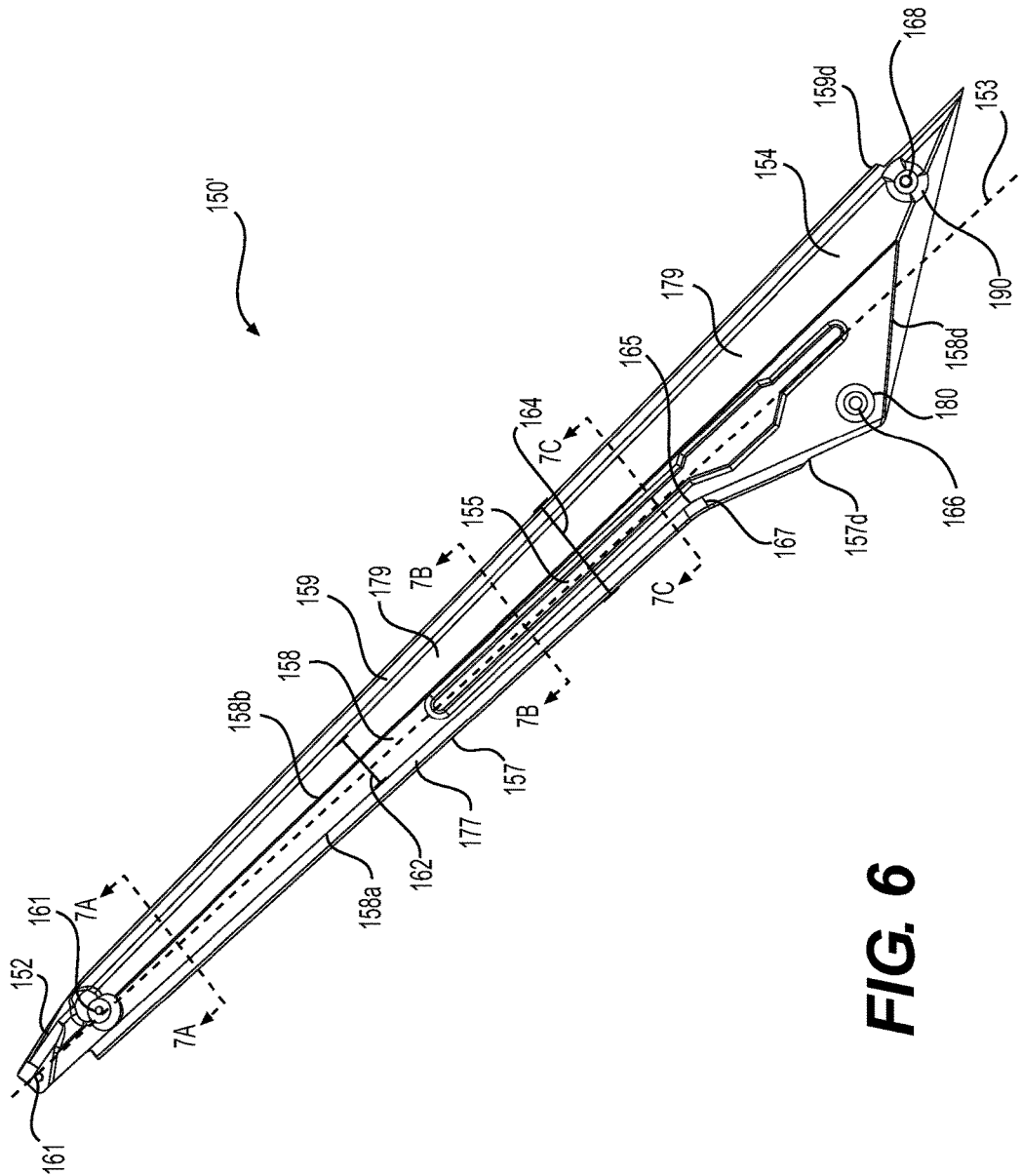
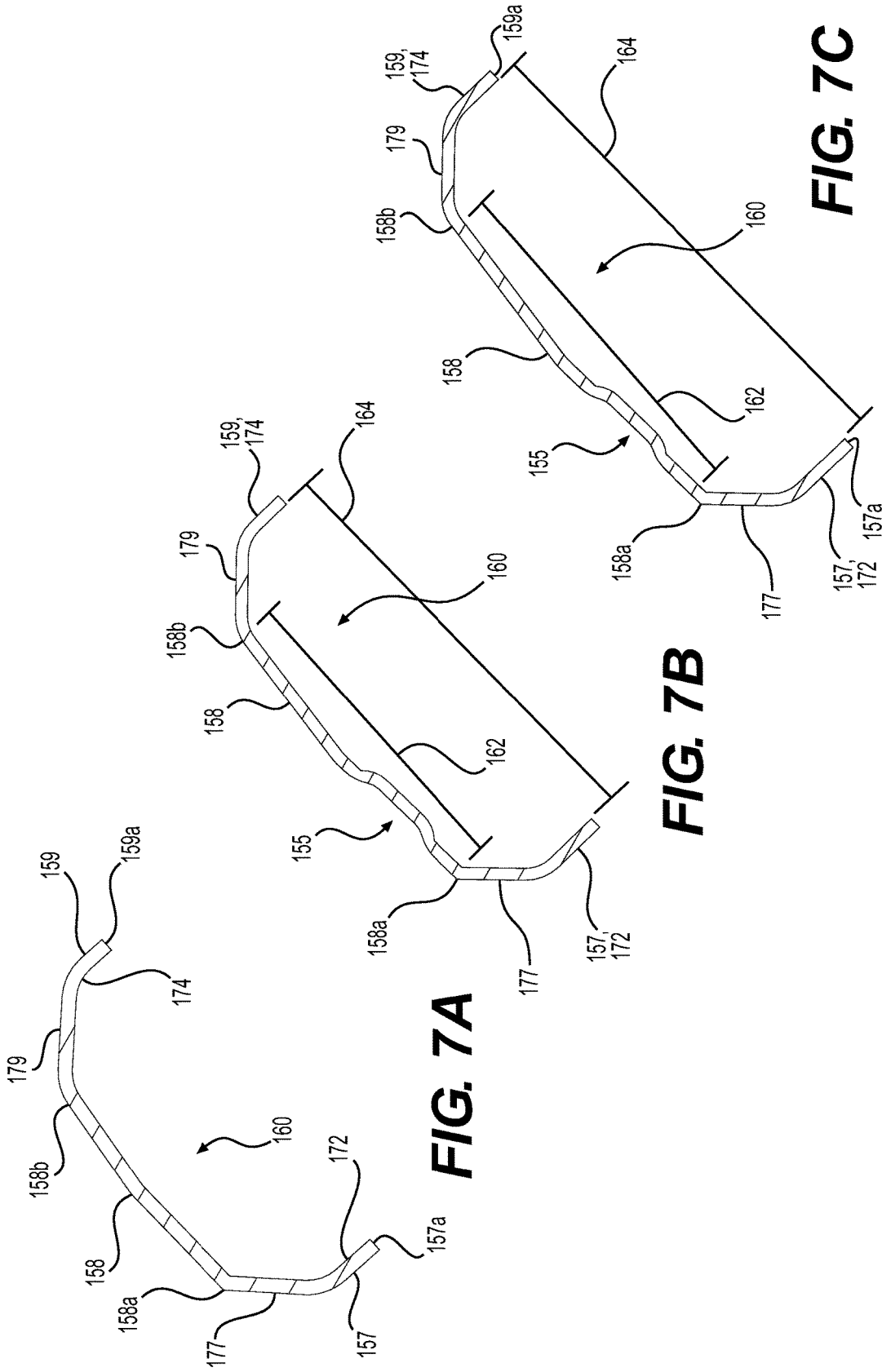

FIG. 6



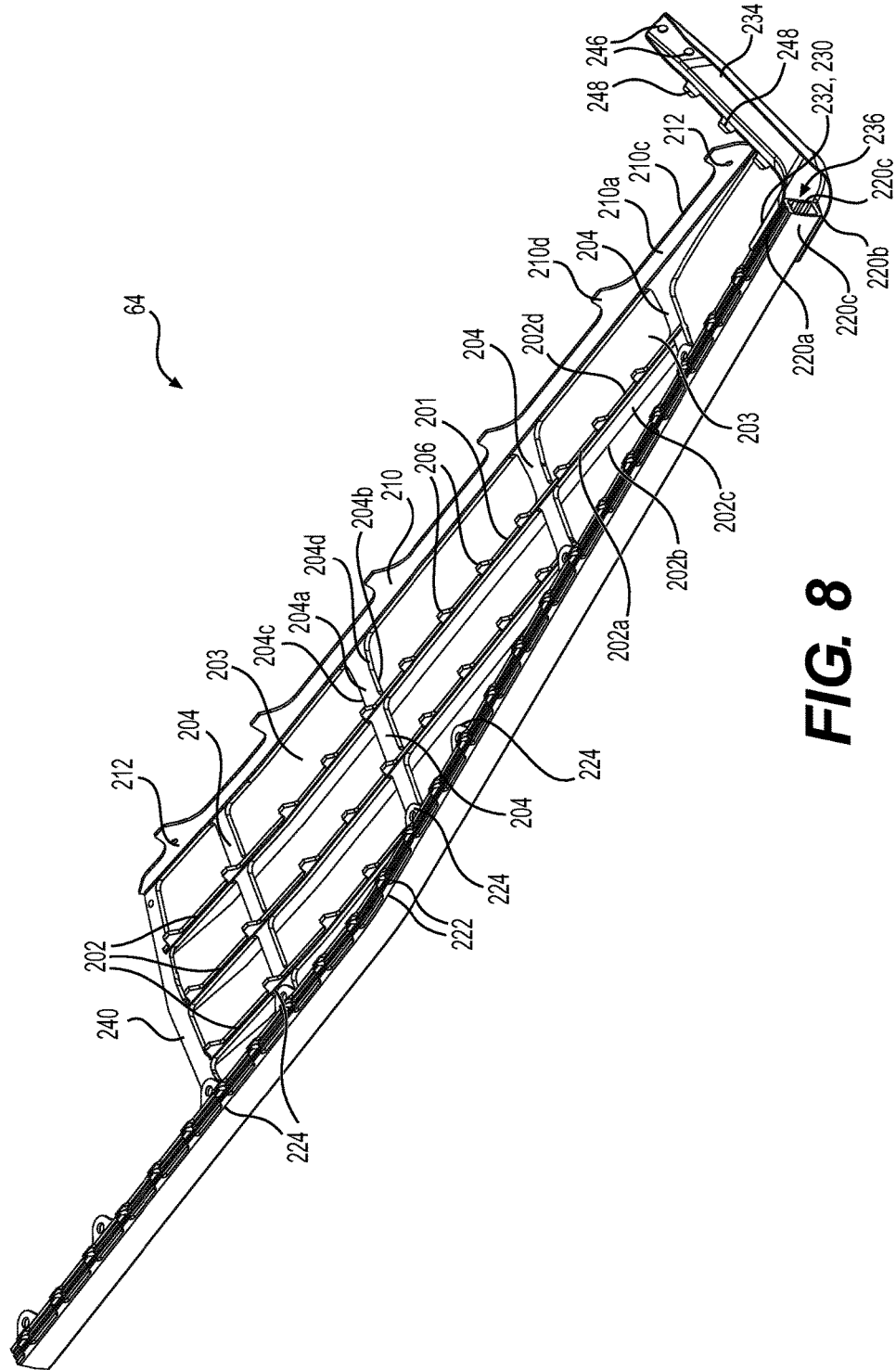

FIG. 8

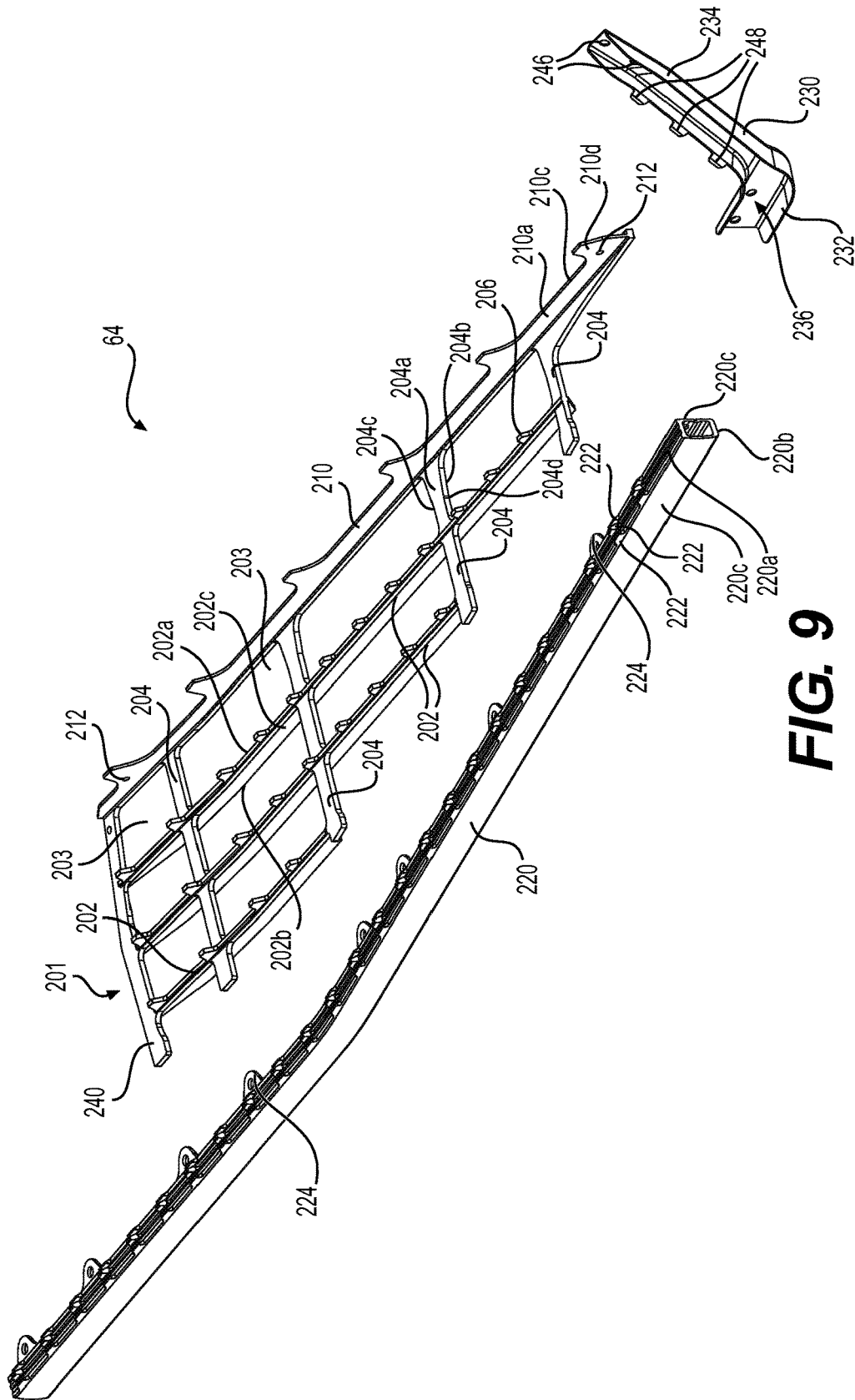

FIG. 9

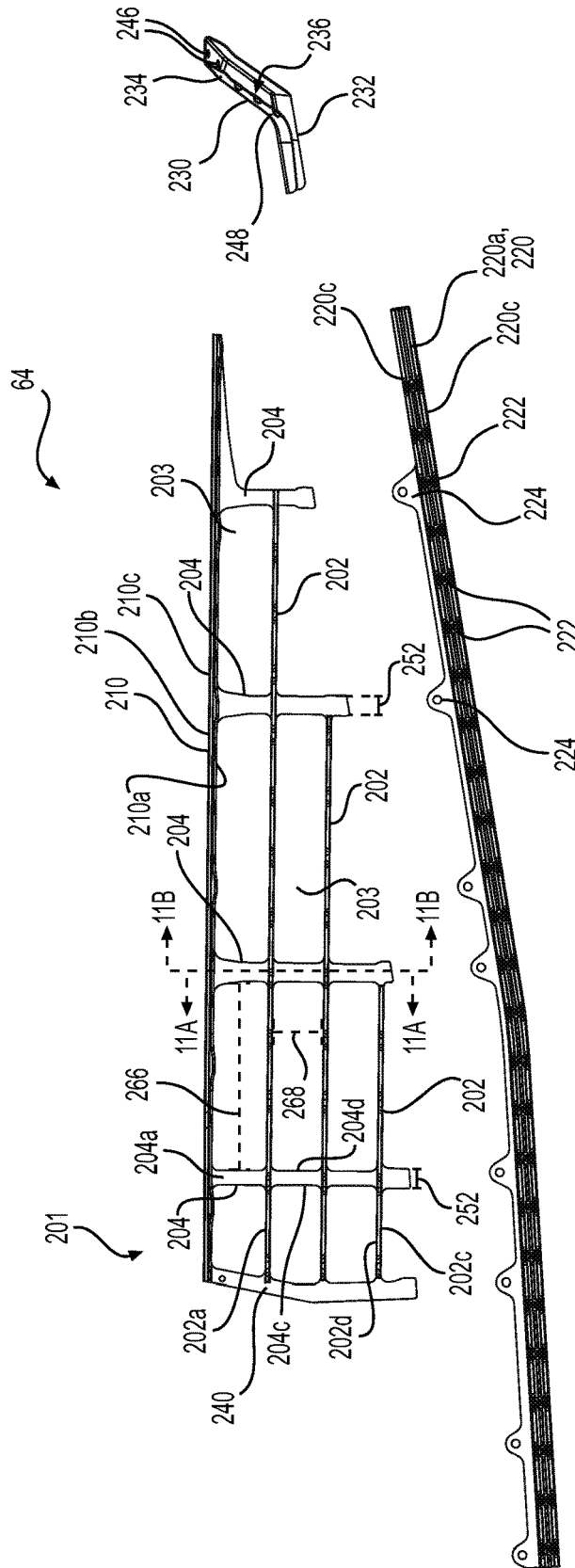

FIG. 10

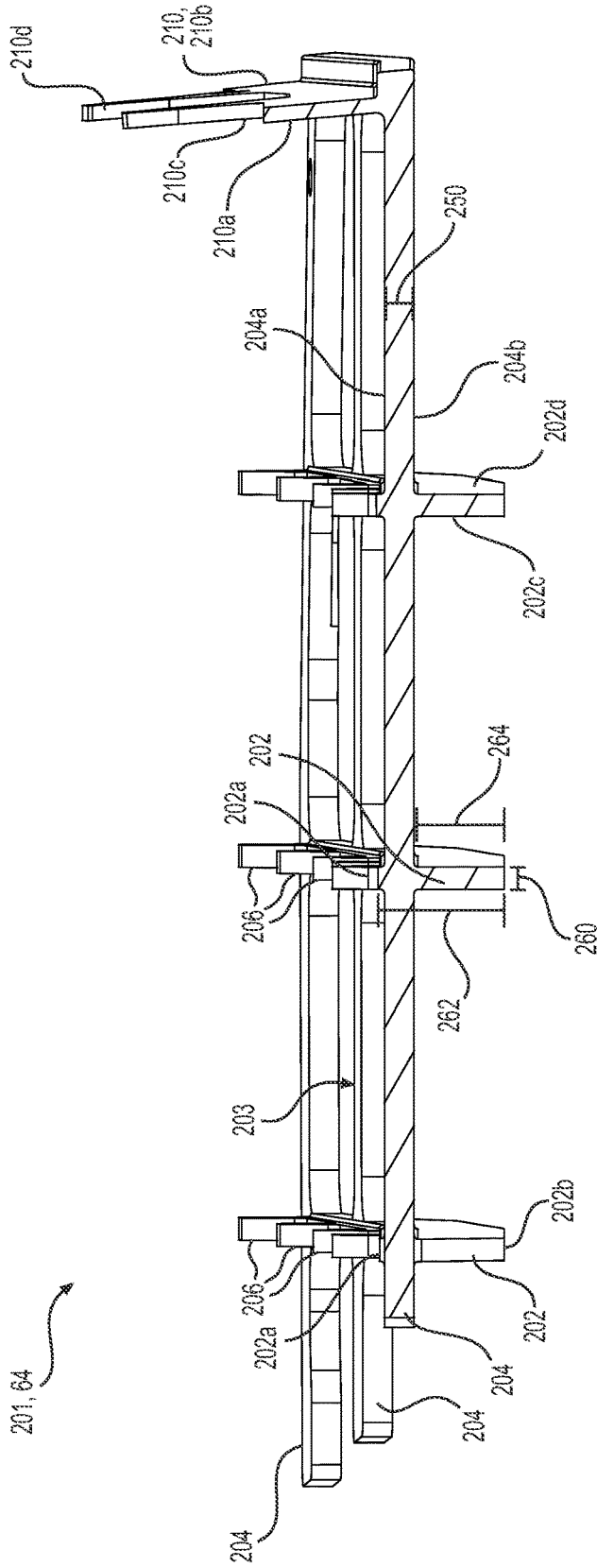

FIG. 11A

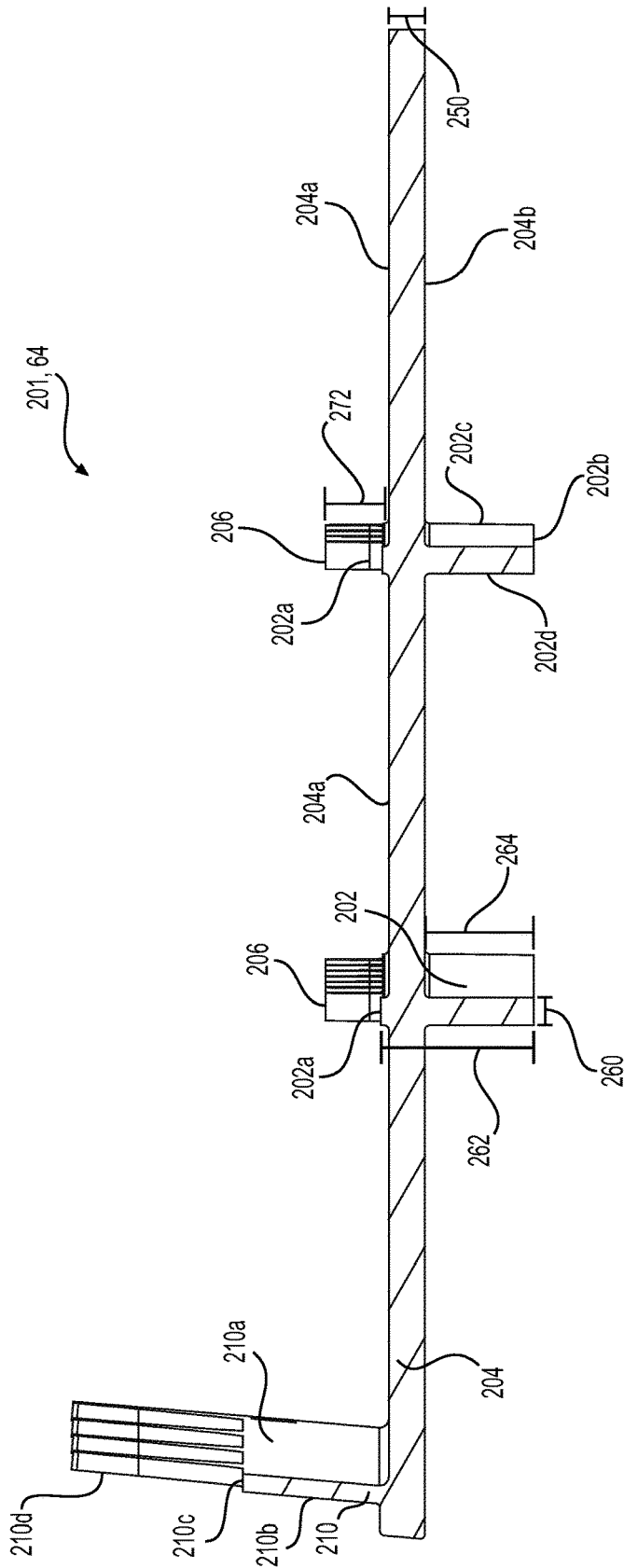

FIG. 11B

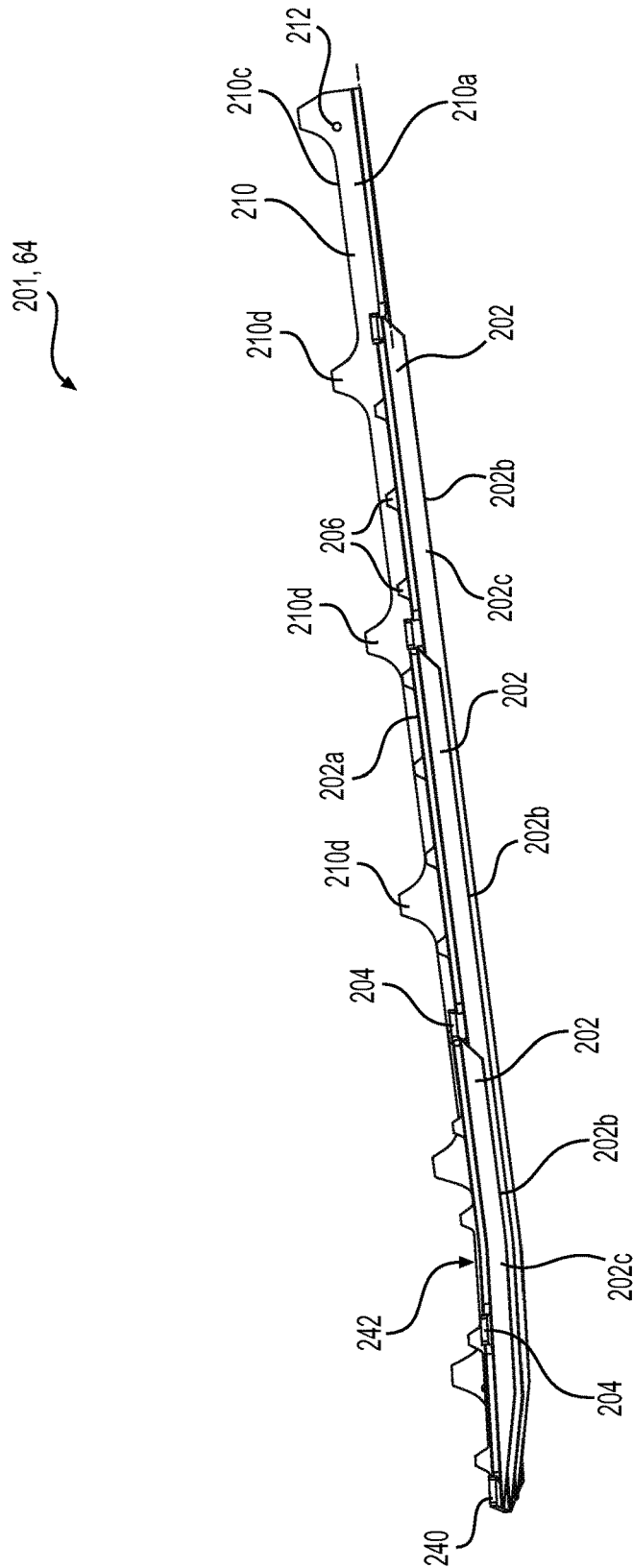

FIG. 12

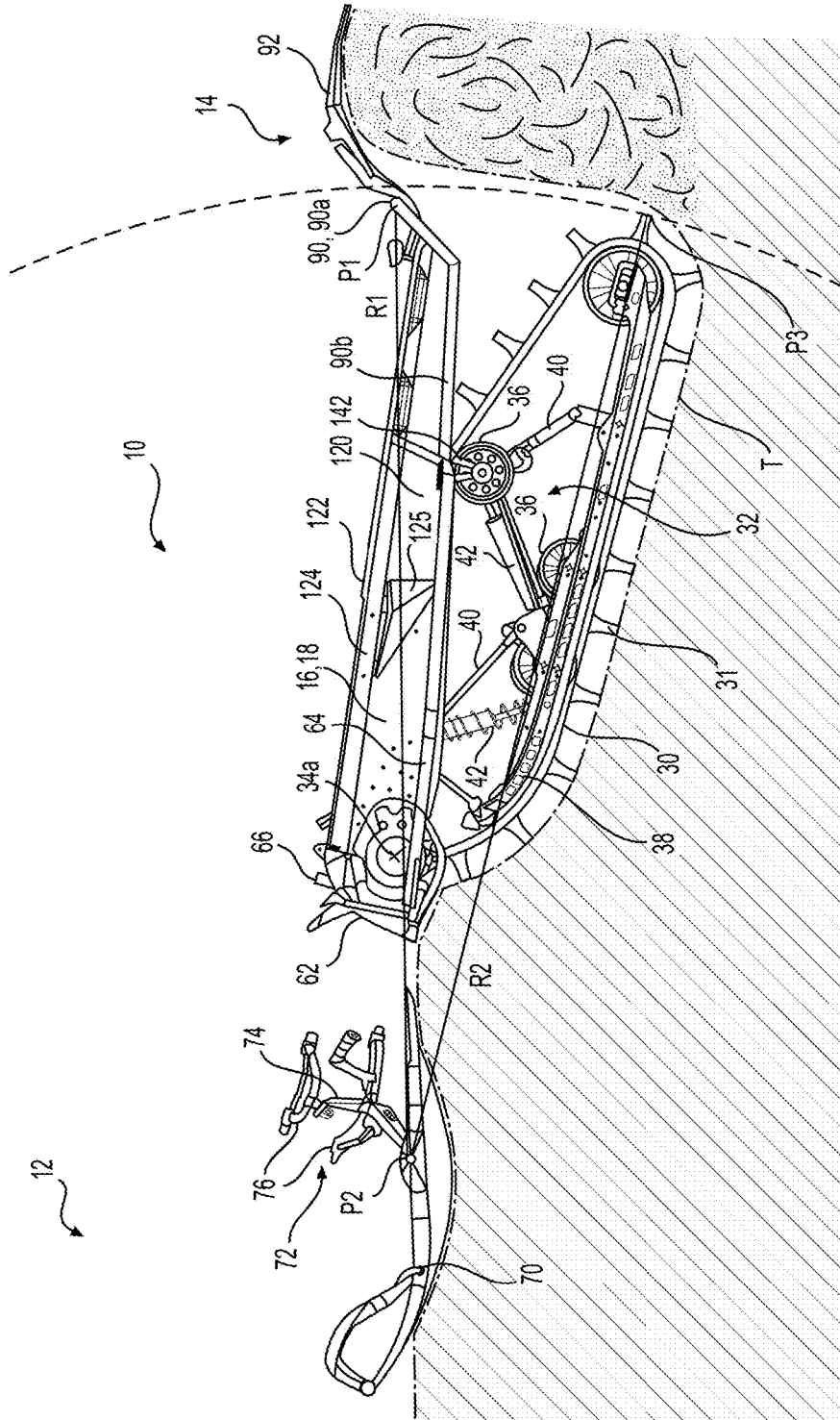

FIG. 13

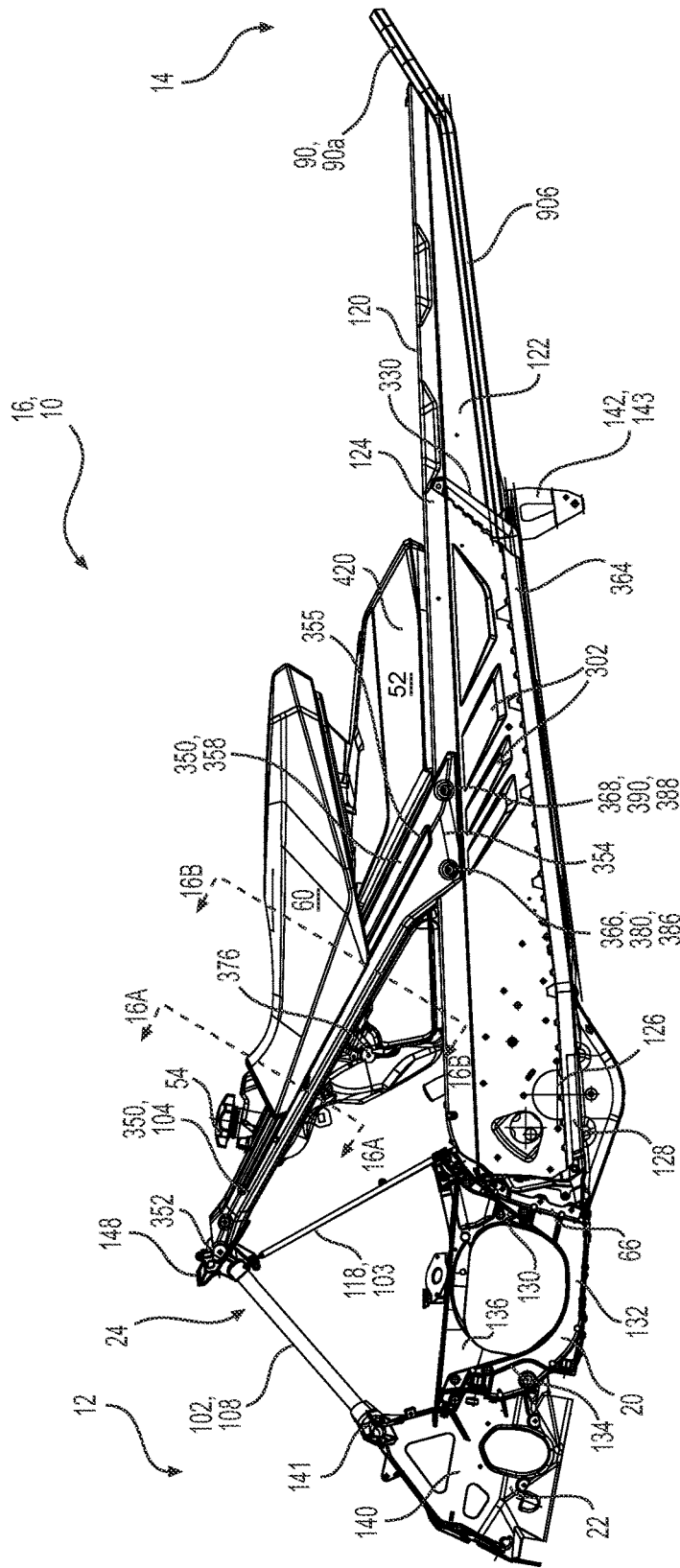

FIG. 14

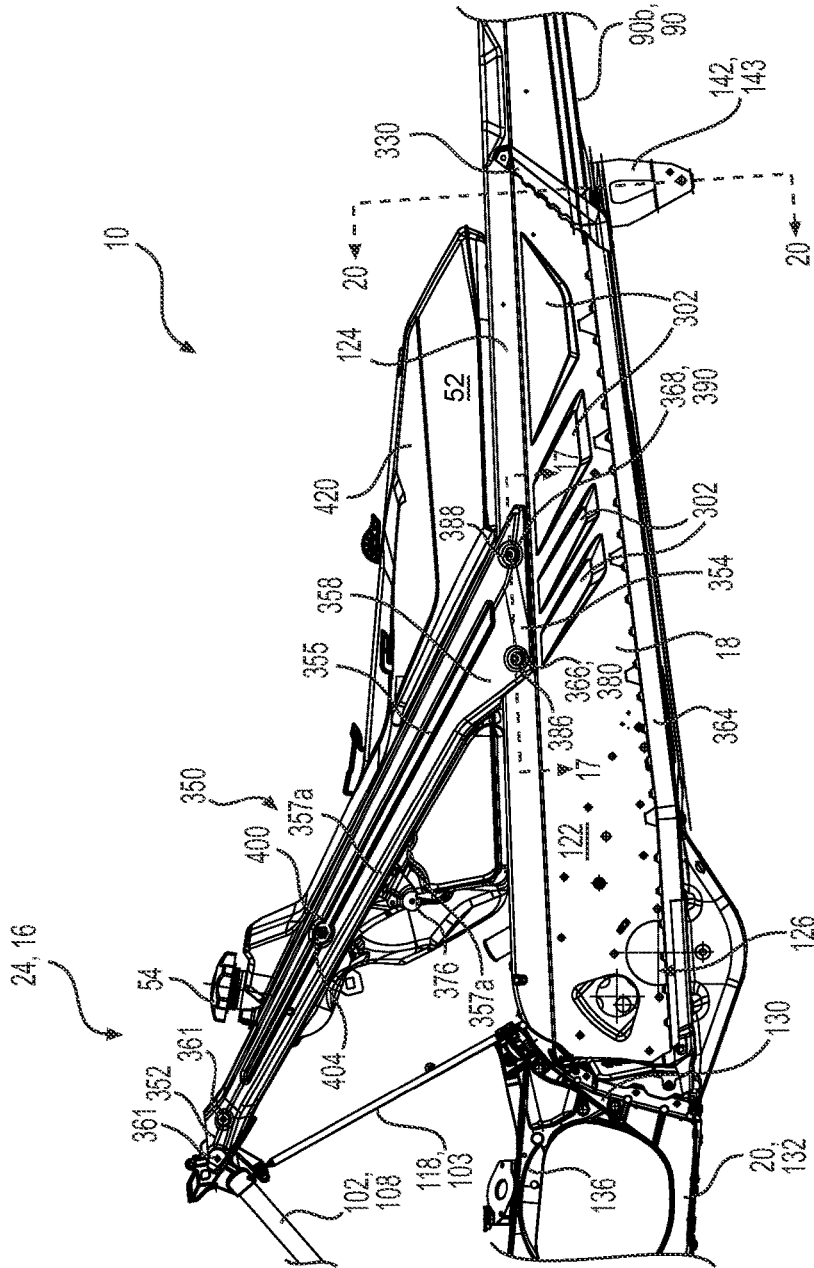

FIG. 15

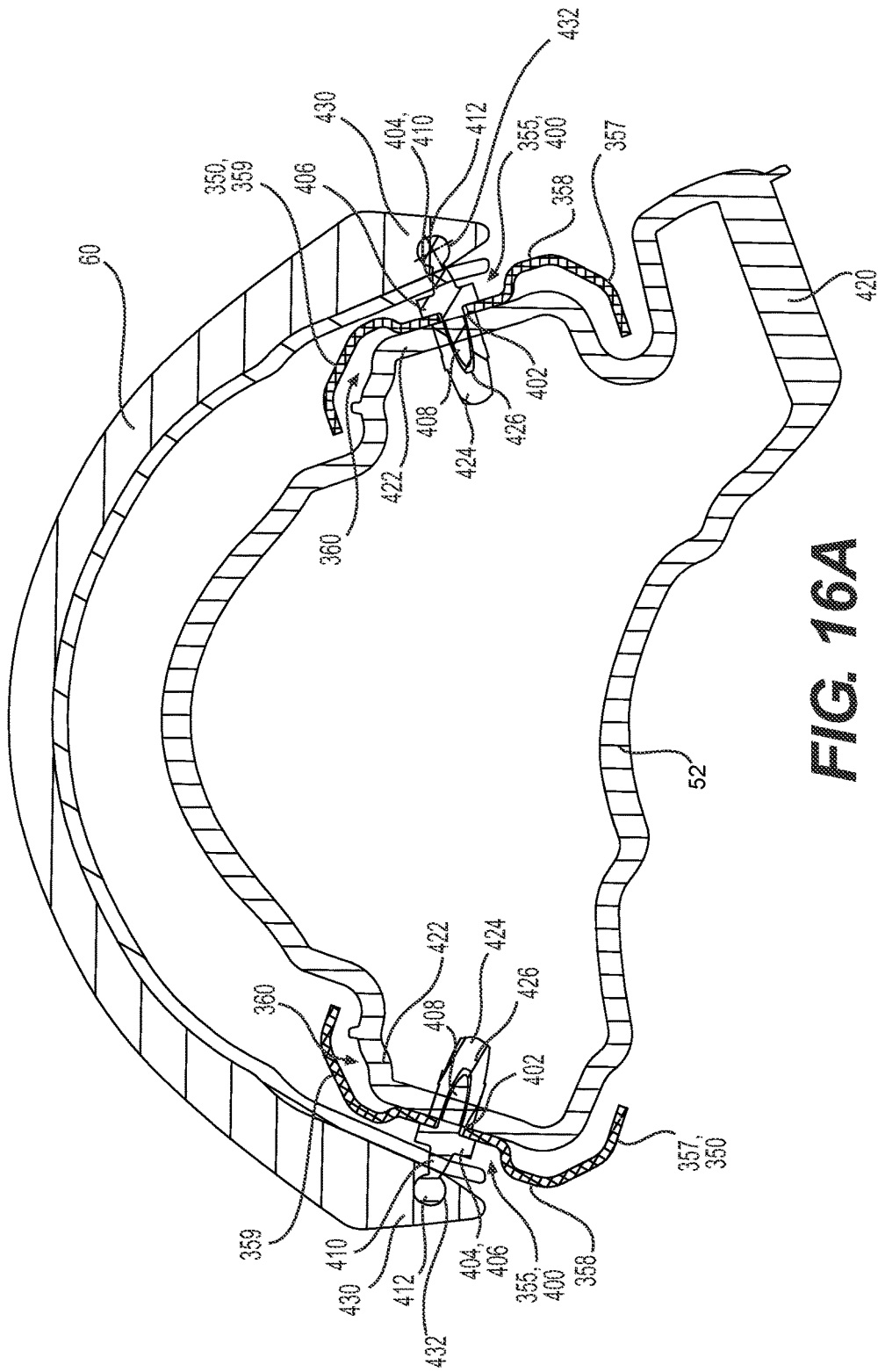

FIG. 16A

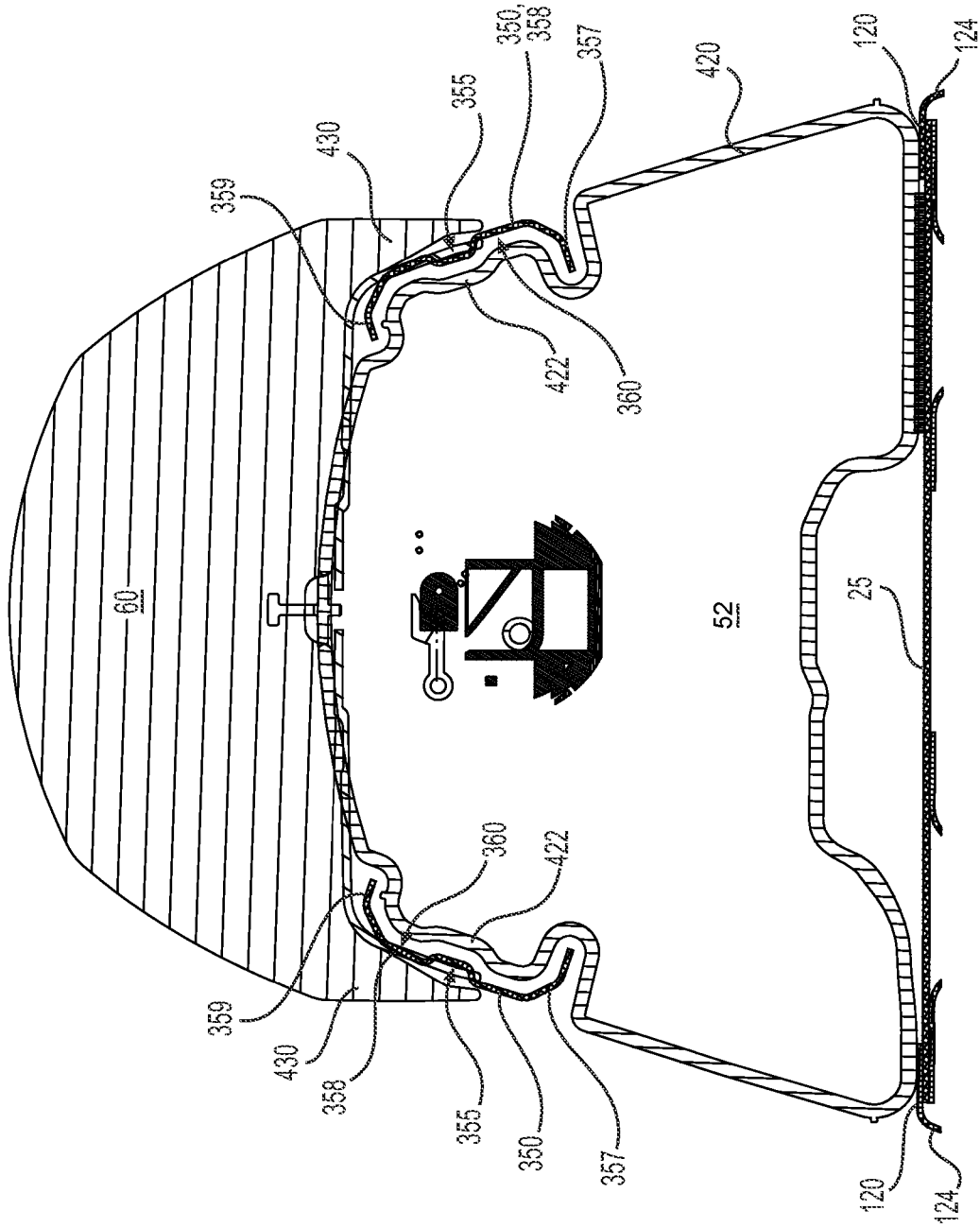

FIG. 16B

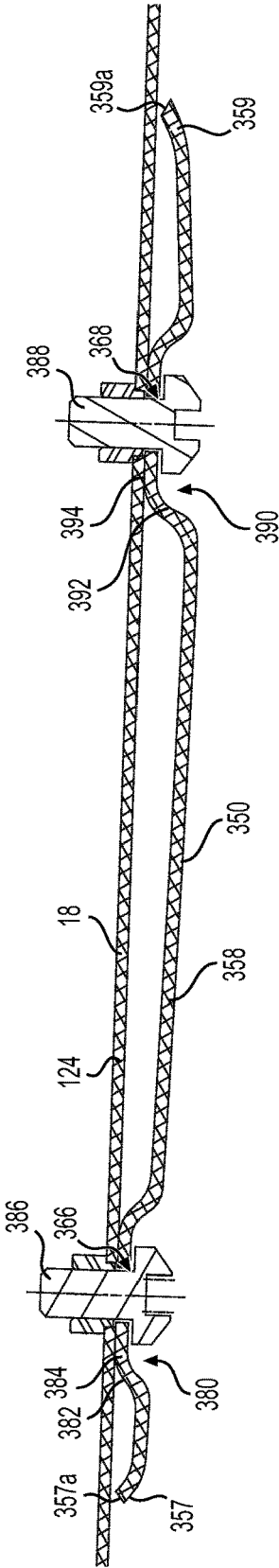

FIG. 17

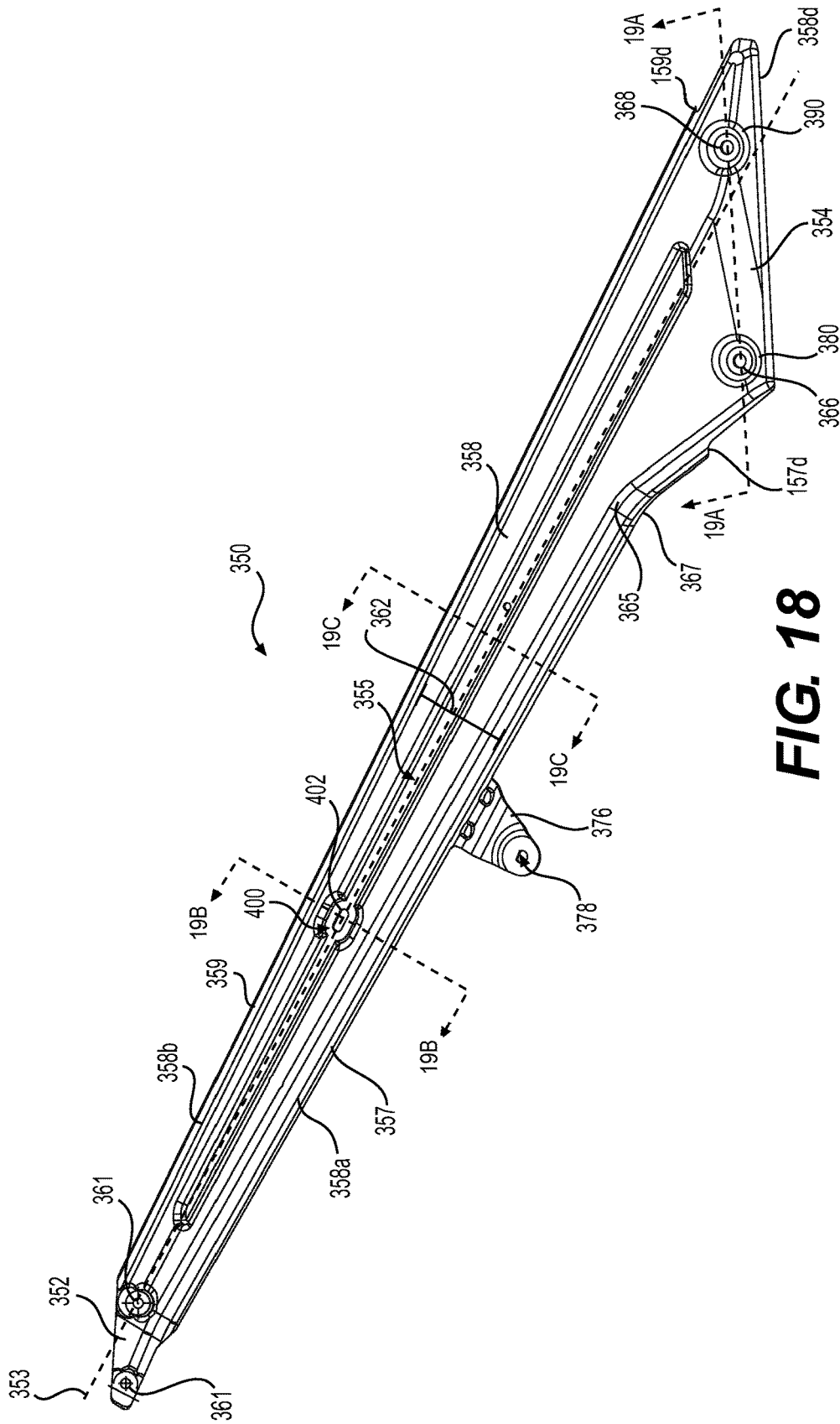

FIG. 18

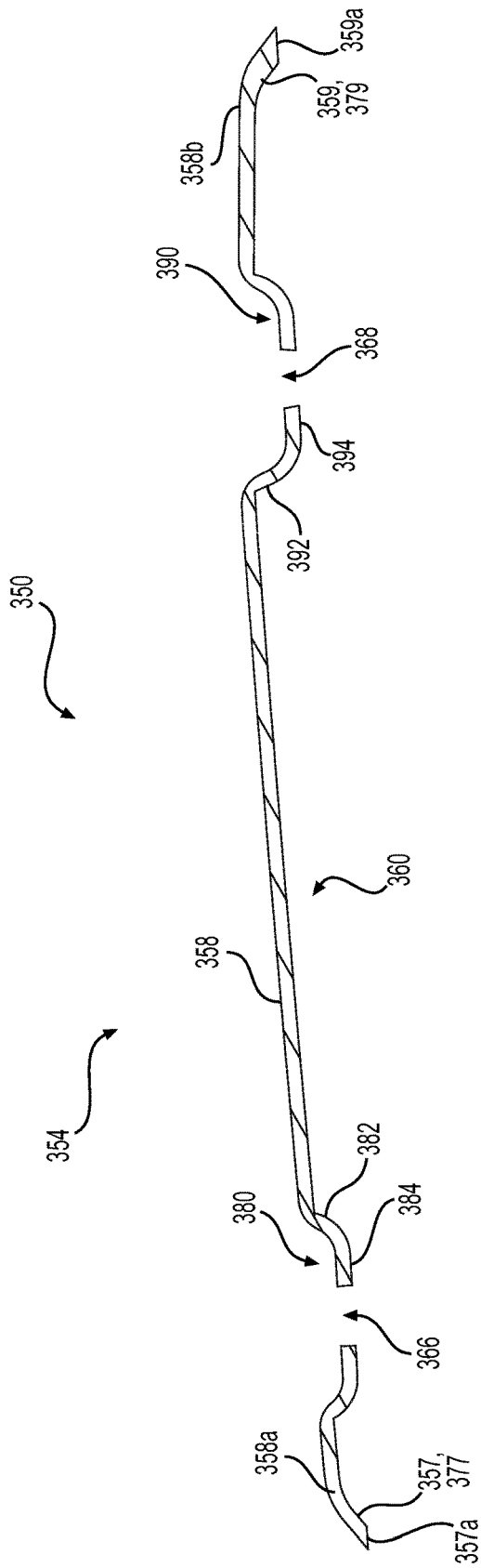

FIG. 19A

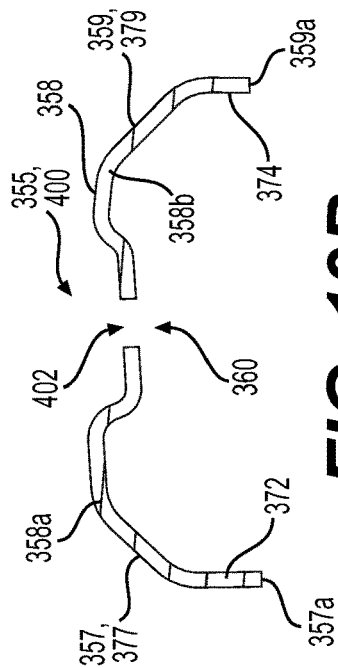

FIG. 19B

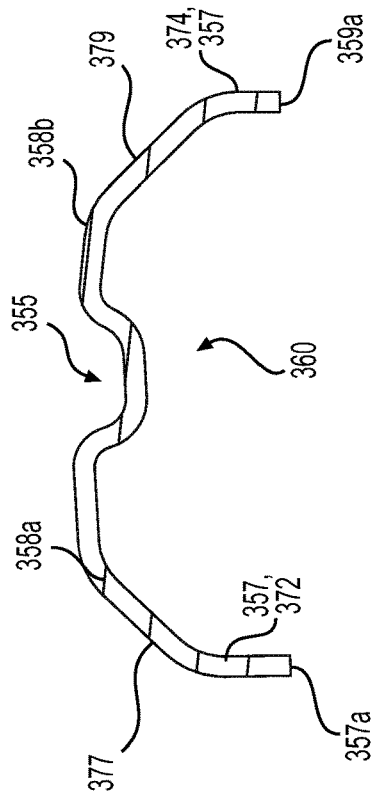

FIG. 19C

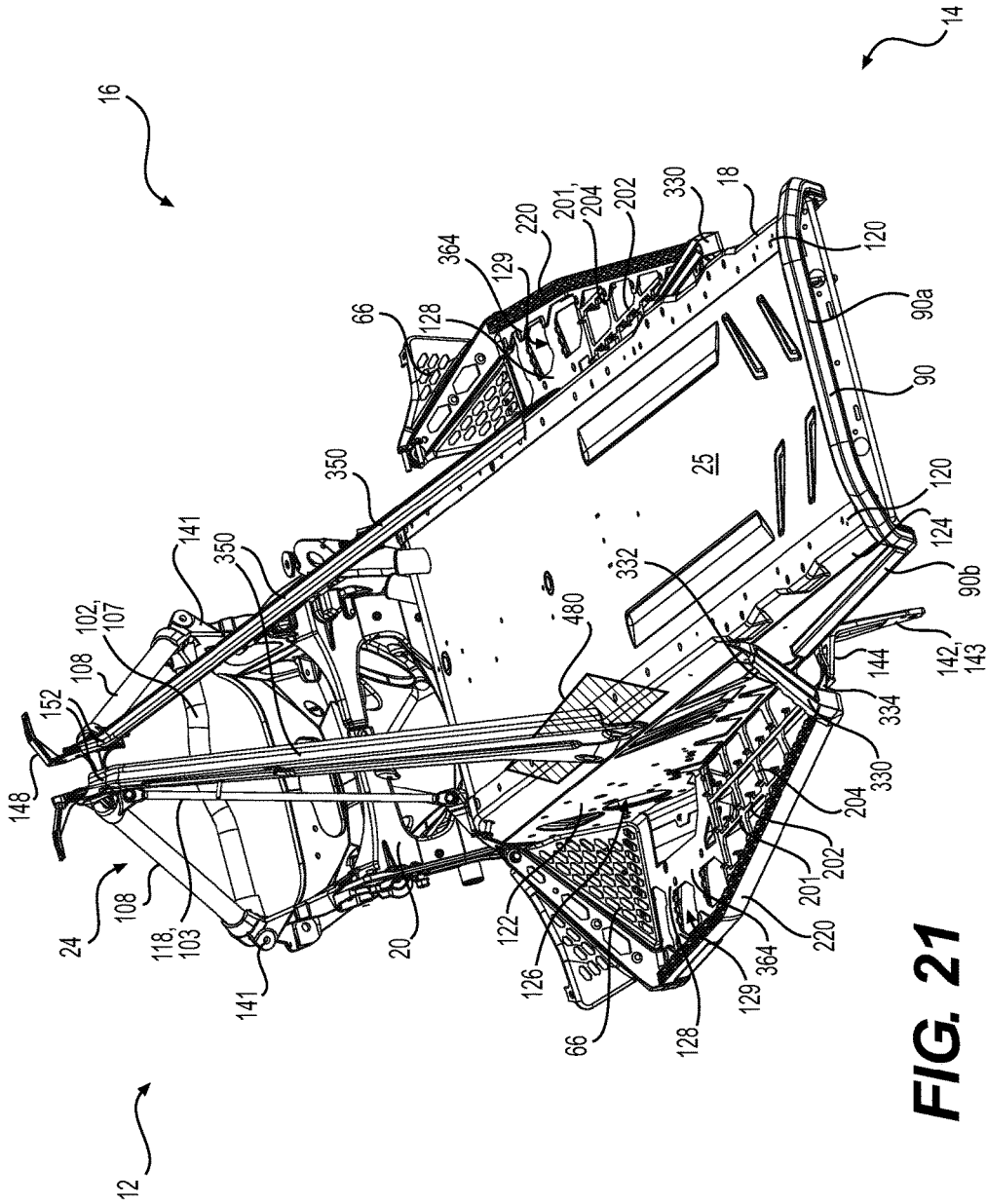

FIG. 21

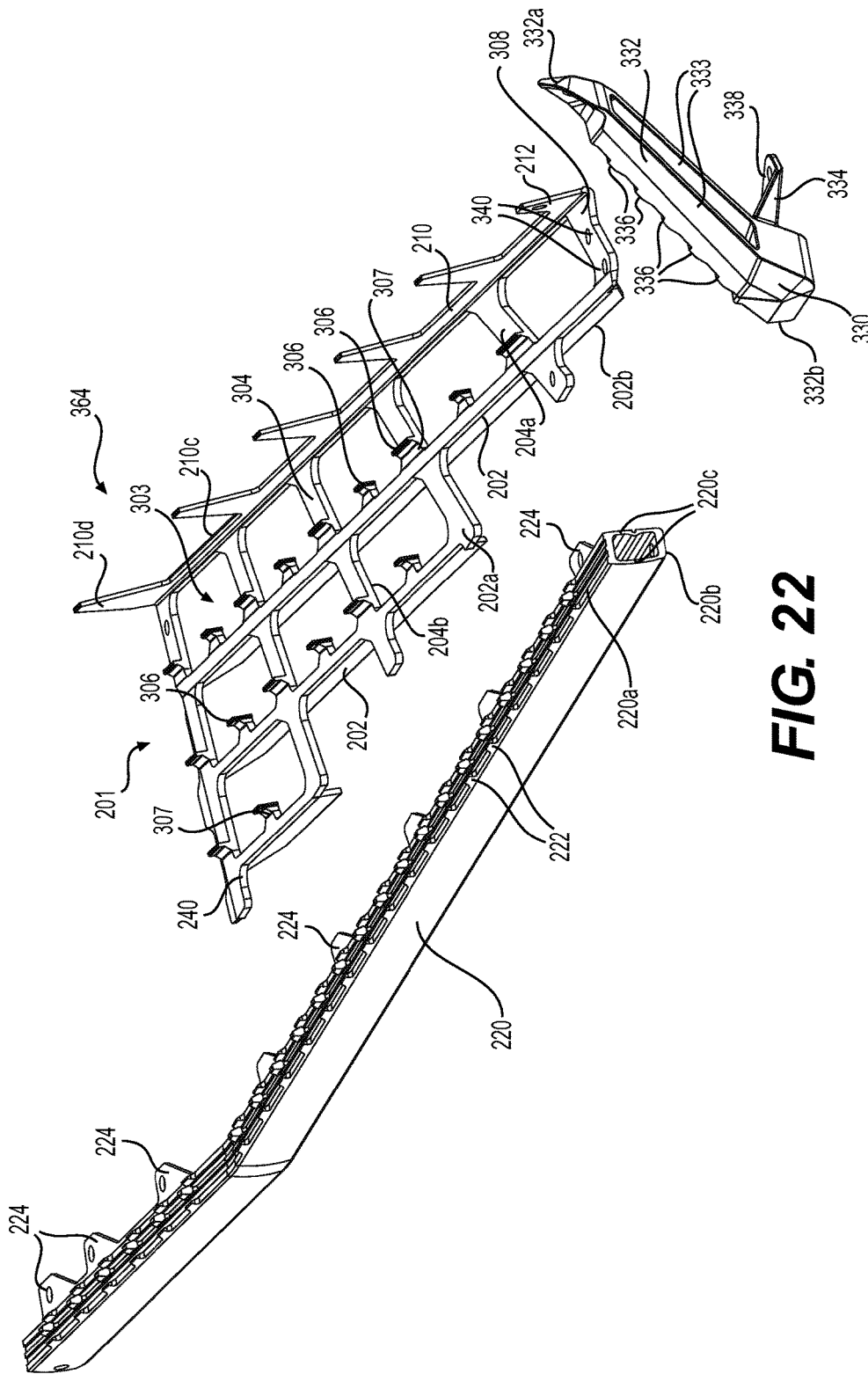

FIG. 22

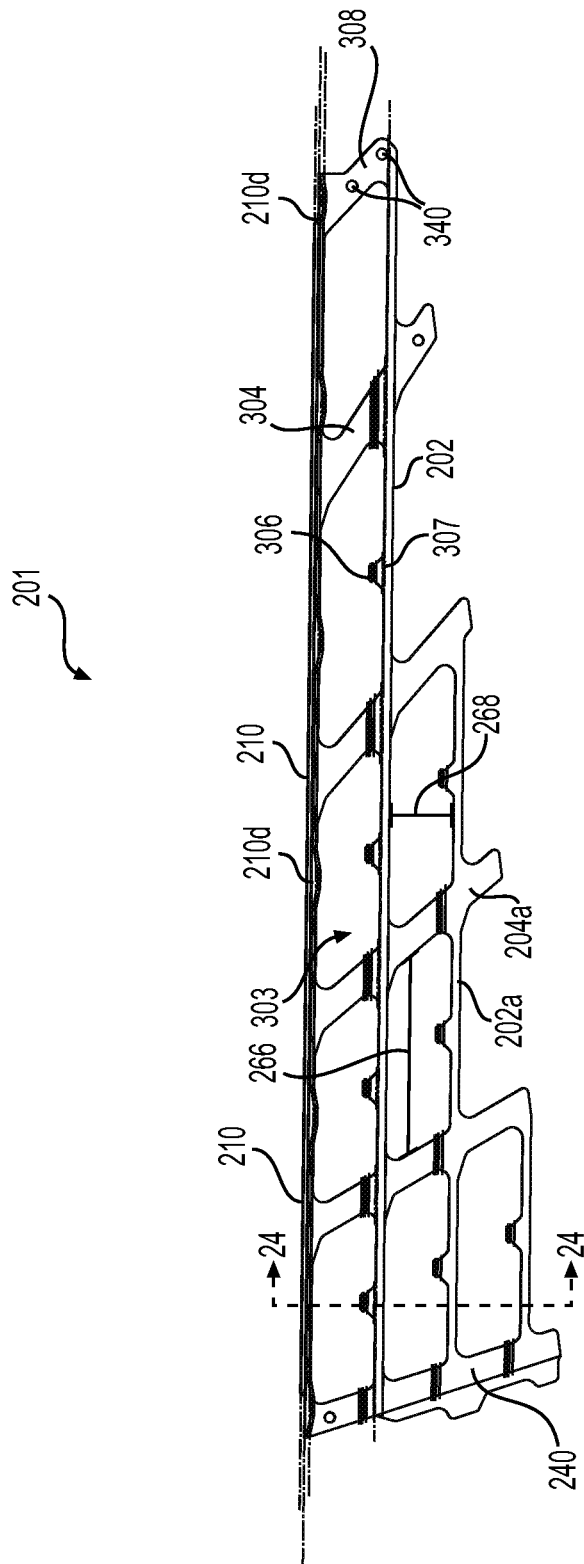

FIG. 23

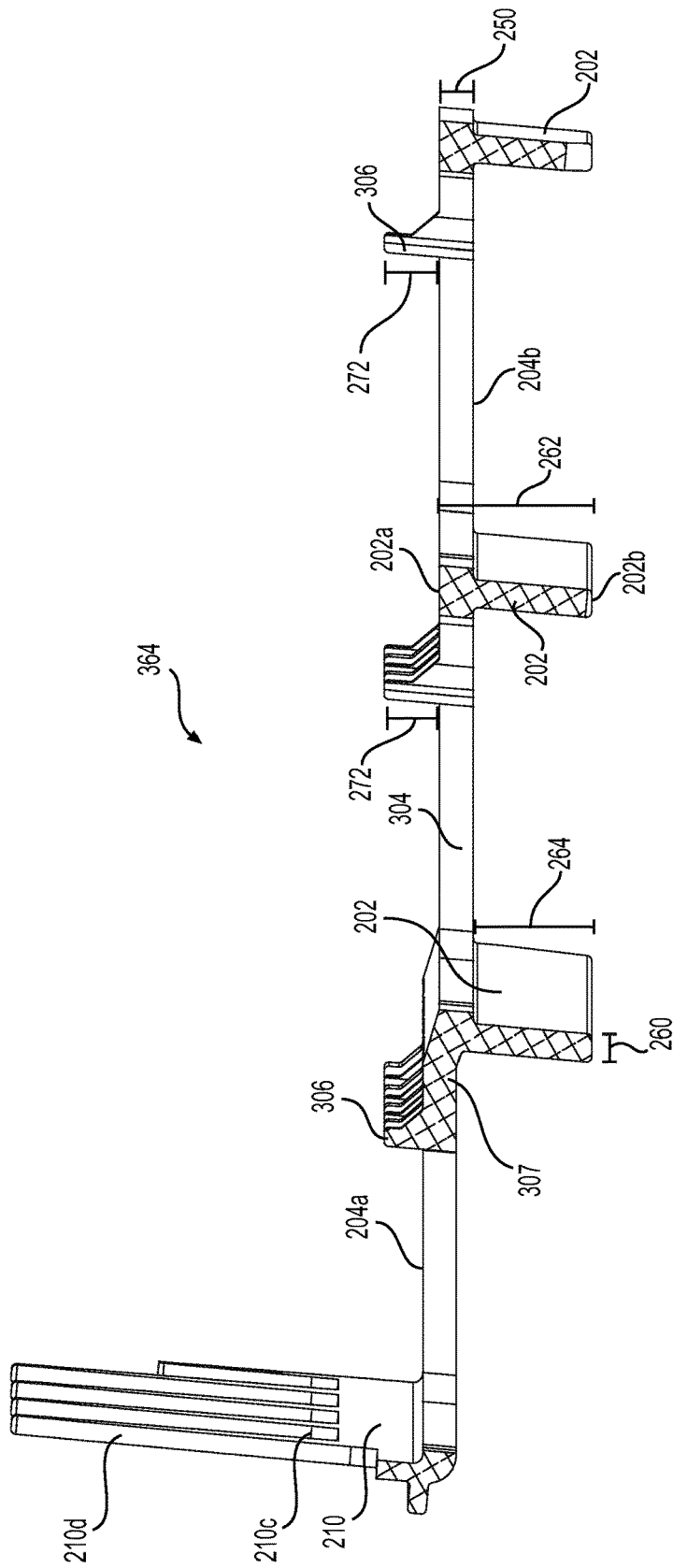

FIG. 24

SNOWMOBILE FRAME STRUCTURE

CROSS-REFERENCE

The present application claims priority to U.S. Provisional Patent Application No. 62/019,259, filed on Jun. 30, 2014, the entirety of which is incorporated herein by reference.

TECHNICAL FIELD

The present technology relates to frames for snowmobiles.

BACKGROUND

Snowmobiles are designed for travel on groomed trails as well as off-trail areas, and for different uses such as recreational purposes or for carrying loads. It is therefore desirable to design snowmobile frames to be rugged so that they can withstand different kinds of compression and torsional forces experienced while driving on different terrains and under different conditions. For improved fuel efficiency and for better handling of a snowmobile in different riding conditions, it is also desirable to reduce the weight of the frame.

SUMMARY

One object of the present is to ameliorate at least some of the inconveniences of the prior art.

In one aspect of the present technology, there is provided a snowmobile having a frame, a front suspension assembly and a rear suspension assembly connected to the frame, at least one ski operatively connected to the front suspension assembly, an endless drive track operatively connected to the rear suspension assembly, and a motor supported by the frame and operatively connected to the drive track for propelling the snowmobile. The frame includes a longitudinally extending tunnel, the rear suspension assembly being connected to the tunnel. The tunnel includes a top wall extending generally horizontally and comprising a left edge and a right edge, a planar left bevel wall extending downwardly and leftwardly from the left edge, a left side wall extending downwardly from the left bevel wall, a planar right bevel wall extending downwardly and rightwardly from the right edge, and a right side wall extending downwardly from the right bevel wall. An upper rear support includes a left leg and a right leg. Each of the left and right legs have a lower end connected to the corresponding one of the left bevel wall and the right bevel wall and extend forwardly, upwardly and laterally inwardly therefrom to an upper end.

In some implementations, each of the left and right legs formed by a side wall being generally planar and having a recess defined in the lower end. The recess of each of the left and right legs has an inner wall being spaced from the side wall and being connected to a corresponding one of the left bevel wall and the right bevel wall of the tunnel. The corresponding one of the left leg and the right leg is thereby connected to the tunnel, a portion of the side wall adjacent the recess in each of the left and right legs being spaced from the tunnel.

In some implementations, the side wall of the left leg extends generally parallel to the left bevel wall, and the side wall of the right leg extends generally parallel to the right bevel wall.

In some implementations, each of the left leg and the right leg includes a front wall extending laterally inwardly from a front edge of the side wall and a rear wall extending laterally inwardly from a rear edge of the side wall.

In some implementations, for each of the left and right legs, the front wall extends from the front edge of the side wall at an obtuse angle with respect to the planar side wall.

In some implementations, for each of the left and right legs, the rear wall extends from the rear edge of the side wall at an obtuse angle with respect to the planar side wall

In some implementations, each of the left and right legs is a sheet metal structure forming a C-shaped cross-section between the upper and lower ends,

In some implementations, for each of the left and right legs, a width of the side wall between the front edge and rear edge thereof tapers towards the upper end.

In some implementations, for each of the left and right legs, the front wall extends from the side wall along an entire length of the corresponding one of the left leg and the right leg below the upper end, and the rear wall extends from the side wall along an entire length of the corresponding one of the left leg and the right leg.

In some implementations, for each of the left and right legs, the front wall extends laterally inwardly from the front edge of the side wall to an inner edge of the front wall, the inner edge of the front wall being disposed further from the side wall in an upper portion of the corresponding one of the left leg and the right leg than in the lower end thereof. The rear wall extends laterally inwardly from the rear edge of the side wall to an inner edge of the rear wall, the inner edge of the rear wall being disposed further from the side wall in an upper portion of the corresponding one of the left leg and the right leg than in the lower end thereof.

In some implementations, for each of the left and right legs, the inner edge of the front wall below the top wall of the tunnel is disposed between the side wall and the corresponding one of the left and right bevel wall. The inner edge of the rear wall below the top wall of the tunnel is disposed between the side wall and the corresponding one of the left and right bevel wall.

In some implementations, a left bevel plane contains the left bevel wall and a right bevel plane contains the right bevel wall. For each of the left leg and the right leg, the inner edge of the front wall is disposed laterally inwardly of the corresponding bevel wall above the top wall of the tunnel. For each of the left leg and the right leg, the inner edge of the rear wall is disposed laterally inwardly of the corresponding bevel wall above the top wall of the tunnel.

In some implementations, the motor is an engine, and the snowmobile further includes

a fuel tank disposed on the tunnel between the left leg and the right leg, the left leg being connected to a left side portion of the fuel tank, and the right leg being connected to a right side portion of the fuel tank.

In some implementations, each of the left leg and the right leg includes a front wall extending laterally inwardly from a front edge of the side wall and a rear wall extending laterally inwardly from a rear edge of the side wall. The left side portion of the fuel tank is disposed between the front wall and the rear wall of the left leg. The right side portion of the fuel tank is disposed between the front wall and the rear wall of the right leg.

In some implementations, a seat disposed on at least one of the fuel tank and the tunnel. A fastener connects the seat and one of the left side portion and the right side portion of the fuel tank to the corresponding one of the left leg and the right leg.

In some implementations, the fastener is a left fastener connecting the seat and the left side portion of the fuel tank to the left leg. The snowmobile further includes a right fastener connecting the seat and the right side portion of the fuel tank to the right leg. The left fastener detachably connects the seat to the left leg, the seat being detachable from the left leg without removing the left fastener from the left leg and fuel tank, and without disconnecting the fuel tank from the left leg. The right fastener detachably connects the seat to the right leg, the seat being detachable from the right leg without removing the fastener from the left leg and fuel tank, and without disconnecting the fuel tank from the left leg.

In some implementations, each of the left and right legs further includes at least one longitudinally extending recess defined in the side wall and disposed between the upper and lower ends.

In some implementations, a steering bracket receives therethrough a steering column operatively connected to the at least one ski. The upper end of each of the left and right legs is connected to the steering bracket.

In some implementations, each of the left and right legs is formed as a single integral structure.

For purposes of this application, terms related to spatial orientation such as forwardly, rearwardly, upwardly, downwardly, left, and right, are as they would normally be understood by a driver of the vehicle sitting thereon in a normal riding position. Terms related to spatial orientation when describing or referring to components or sub-assemblies of the vehicle, separately from the vehicle, such as the ice scratcher for example, should be understood as they would be understood when these components or sub-assemblies are mounted to the vehicle.

Implementations of the present technology each have at least one of the above-mentioned aspects, but do not necessarily have all of them. It should be understood that some aspects of the present technology that have resulted from attempting to attain the above-mentioned object may not satisfy this object and/or may satisfy other objects not specifically recited herein.

Additional and/or alternative features, aspects, and advantages of implementations of the present technology will become apparent from the following description, the accompanying drawings, and the appended claims.

BRIEF DESCRIPTION OF THE DRAWINGS

For a better understanding of the present technology, as well as other aspects and further features thereof, reference is made to the following description which is to be used in conjunction with the accompanying drawings, where:

FIG. 1 is a partially cut-away left side elevation view of a portion of a snowmobile;

FIG. 2A is a left side elevation view of a portion of the snowmobile of FIG. 1;

FIG. 2B is a perspective view, taken from a rear, left side, of the snowmobile portion of FIG. 2A;

FIG. 2C is a top plan view of the snowmobile portion of FIG. 2A;

FIG. 2D is a cross-sectional view taken along the line 2D-2D of FIG. 2C;

FIG. 3 is a left side elevation view of a left leg of an upper rear support of the frame of the snowmobile of FIG. 1;

FIG. 4A is a line section taken along the line 4A-4A of FIG. 3;

FIG. 4B is a line section taken along the line 4B-4B of FIG. 3;

FIG. 4C is a line section taken along the line 4C-4C of FIG. 3;

FIG. 5A is a rear elevation view of the left leg of FIG. 3;

FIG. 5B is a front elevation view of the left leg of FIG. 3;

FIG. 6 is a left side elevation view of a left leg according to another implementation;

FIG. 7A is a line section taken along the line 7A-7A of FIG. 6;

FIG. 7B is a line section taken along the line 7B-7B of FIG. 6;

FIG. 7C is a line section taken along the line 7C-7C of FIG. 6;

FIG. 8 is a perspective view, taken from a rear, left side, of a left footrest of the snowmobile of FIGS. 2A to 2D;

FIG. 9 is an exploded perspective view, taken from a rear, left side, of the left footrest of FIG. 8;

FIG. 10 is an exploded top plan view of the left footrest of FIG. 8;

FIG. 11A is a cross-sectional view, taken along the line 11A-11A of FIG. 10;

FIG. 11B is a cross-sectional view, taken along the line 11B-11B of FIG. 10;

FIG. 12 is a left side elevation view of a portion of the left footrest of FIG. 8; and

FIG. 13 is a left side elevation view of a portion of the snowmobile of FIG. 1 shown in a trenching configuration, with a snow flap of the snowmobile in a pivoted position;

FIG. 14 is a left side elevation view of a snowmobile frame, fuel tank and seat in accordance with another implementation;

FIG. 15 is a left side elevation view of the snowmobile frame and fuel tank of FIG. 14 with the seat being removed for clarity;

FIG. 16A is a cross-sectional view taken along the line 16A-16A of FIG. 14;

FIG. 16B is a cross-sectional view taken along the line 16B-16B of FIG. 14;

FIG. 17 is a cross-sectional view taken along the line 17-17 of FIG. 15;

FIG. 18 is a left side elevation view of a left leg of an upper rear support of the frame of FIG. 14;

FIG. 19A is a slice taken along the line 19A-19A of FIG. 18;

FIG. 19B is a slice taken along the line 19B-19B of FIG. 18;

FIG. 19C is a slice taken along the line 19C-19C of FIG. 18;

FIG. 20 is a slice taken along the line 20-20 of FIG. 15;

FIG. 21 is a perspective view, taken from a rear, top and left side, of the frame and footrests of FIG. 14;

FIG. 22 is an exploded perspective view, taken from a rear, top and left side, of the left footrest of FIG. 21;

FIG. 23 is a top plan view of a portion of the left footrest of FIG. 22; and

FIG. 24 is a cross-sectional view taken along the line 24-24 of FIG. 23.

DETAILED DESCRIPTION

Referring to FIG. 1, a snowmobile 10 includes a forward end 12 and a rearward end 14 which are defined consistently with a travel direction of the vehicle 10. The snowmobile 10 includes a vehicle body in the form of a frame or chassis 16

which includes a rear tunnel 18, an engine cradle 20, a front suspension module 22 and an upper support structure 24. The tunnel 18 defines a longitudinal centerplane 13 (longitudinally disposed vertical plane, FIGS. 2C and 2D) of the snowmobile 10. The frame 16 will be described in further detail below.

A motor 50 (schematically illustrated in FIG. 1), which in the illustrated implementation is an internal combustion engine, is carried in an engine compartment defined by the engine cradle 20. A fuel tank 52, supported above the tunnel 18, supplies fuel to the engine 50 for its operation. Coolant used to cool the engine 50 is circulated through heat exchangers 25 (FIG. 2B) mounted to the tunnel 18.

An endless drive track 30 is positioned at the rear end 14 of the snowmobile 10. The drive track 30 is disposed generally under the tunnel 18, and operatively connected to the motor 50 through a belt transmission system (not shown) and a reduction drive (not shown). The endless drive track 30 is driven to run about a rear suspension assembly 32 connected to the tunnel 18 for propulsion of the snowmobile 10. The endless drive track 30 has a plurality of lugs 31 extending from an outer surface thereof to provide traction to the track 30.

The rear suspension assembly 32 includes a drive sprocket 34, one or more idler wheels 36 and a pair of slide rails 38 in sliding contact with the endless drive track 30. The drive sprocket 34 (shown schematically in FIG. 1) is mounted on a drive axle 35 and defines a sprocket axis 34a. The slide rails 38 are attached to the tunnel 18 by front and rear suspension arms 40 and one or more shock absorbers 42 which include a coil spring (not indicated) surrounding the individual shock absorbers 42. It is contemplated that the snowmobile 10 could be provided with a different implementation of a rear suspension assembly 32 than the one shown herein.

A straddle-type seat 60 is positioned atop the fuel tank 52. It is contemplated that the seat 60 could be positioned on the tunnel 18. The seat 60 and the fuel tank 52 are connected to the upper support structure 24 of the frame 16 as will be described below in further detail. A fuel tank filler opening covered by a cap 54 is disposed on the upper surface of the fuel tank 52 in front of the seat 60. It is contemplated that the fuel tank filler opening could be disposed elsewhere on the fuel tank 52. The seat 60 is adapted to accommodate a driver of the snowmobile 10. The seat 60 can also be configured to accommodate a passenger. A footrest 64, in the form of a footboard, is positioned on each side of the snowmobile 10 below the seat 60 to accommodate the driver's feet. The footrest 64 will be described below in further detail.

Two skis 70 positioned at the forward end 12 of the snowmobile 10 are attached to the front suspension module 22 of the frame 16 through a front suspension assembly 72. The front suspension module 22 is connected to the front end of the engine cradle 24. The front suspension assembly 72 includes ski legs 74, supporting arms 76, shock absorbers 78 and ball joints (not shown) for operatively connecting to the respective ski leg 74, supporting arms 76 and a steering column 82.

A steering assembly 80, including the steering column 82 and a handlebar 84, is provided generally forward of the seat 60. The steering column 82 is rotatably connected to the frame 16. The lower end of the steering column 82 is connected to the ski legs 74 via steering rods 83 (the left end of the left steering rod 83 can be seen in FIG. 1). The handlebar 84 is attached to the upper end of the steering column 82. The handlebar 84 is positioned in front of the

seat 60. The handlebar 84 is used to rotate the steering column 82, and thereby the skis 70, in order to steer the vehicle 10. A throttle operator (not shown) in the form of a thumb-actuated throttle lever is mounted to the right side of the handlebar 84. Other types of throttle operators, such as a finger-actuated throttle lever and a twist grip, are also contemplated. A brake actuator (not indicated), in the form of a hand brake lever, is provided on the left side of the handlebar 84 for braking the snowmobile 10 in a known manner

At the rear end of the snowmobile 10, a rear bumper 90 and a snow flap 92 are connected to the rear end of the tunnel 18. The rear bumper 90, in the form of an inverted U-shaped tubular structure, extends above the rear end of the tunnel 18. The snow flap 92 extends downward from the rear end of the tunnel 18. The snow flap 92 protects against snow that can be projected upward from the drive track 30 when the snowmobile 10 is being driven. The snow flap 92 extends rearwardly from its front end which is disposed between the tunnel 18 and the rear bumper 90, and then extends downwardly. The downwardly extending portion of the snow flap 92 defines a surface facing the track 30 that is arcuate. The lower end of the snow flap 92 is disposed rearward of the rearmost point of the drive track 30. As such, during operation of the snowmobile 10, some of the snow projected rearward by the drive track 30 is redirected upwardly and forwardly so as to be projected onto the heat exchanger 25 connected to the tunnel 18 to improve cooling.

As can be seen in FIG. 13, the snow flap 92 can also pivot and bend relative to the tunnel 18. Under certain conditions, it is possible for the drive track 30 to have reduced traction with the surface on which it travels. Should this surface be deep loose snow, the drive track 30 can start digging into the snow thereby forming a trench until it regains traction, which is sometimes referred to as trenching. In prior art snowmobiles, the tunnel 18 and/or the rear bumper 90 extends further rearward than in the snowmobile 10 described herein. As a result, after a certain amount of trenching, the rear portion of the tunnel 18 and/or of the rear bumper 90 can sit on the edge of the trench dug by the drive track 30. The snow flap 92 bridging between the end of the tunnel 18 and the bumper 90 increases support for the snowmobile 10 on the edge of the trench. As a result, the snowmobile 10 can no longer move down as the drive track 30 digs the trench, which eventually result in the drive track 30 no longer being capable of digging and losing all traction. This is sometimes referred to as jacking. In the snowmobile of the present implementation, the rearmost point P1 of the rear bumper 90 is disposed at a distance R1 from the point P2 about which the ski 70 pivots relative to the ski leg 74. The rearwardmost point P3 of the track 30 is disposed at a distance R2 from point P2. By having R1 less than R2, the rearmost point of the bumper 90, which in the present implementation is further back than the tunnel 18, remains inside the trench T dug by the track 30 and will not sit on the edge of the trench T, thus preventing jacking. Although a portion of the snow flap 92 extending rearward of the bumper 90 may contact the edge to the trench T as shown, since the snow flap 92 is made of flexible material, it bends when the weight of the snowmobile 10 is applied to it, and therefore does not cause jacking.

At the front end 12 of the snowmobile 10, fairings 94 enclose the motor 50 and the belt transmission system, thereby providing an external shell that not only protects the motor 50 and the transmission system, but can also be decorated to make the snowmobile 10 more aesthetically pleasing. Typically, the fairings 94 include a hood 96 and

one or more side panels which can be opened to allow access to the motor 50 and the belt transmission system when this is required, for example, for inspection or maintenance of the motor 50 and/or the transmission system. A windshield 98 connected to the fairings 94 acts as a wind screen to lessen the force of the air on the rider while the snowmobile 10 is moving. The windshield 98 may be connected directly to the handlebar 84.

The snowmobile 10 includes other components such as a display cluster, an exhaust system, an air intake system, and the like. As it is believed that these components would be readily recognized by one of ordinary skill in the art, further explanation and description of these components will not be provided herein.

The frame 16 will now be described in more detail with reference to FIGS. 2A to 2D, 14, 15, 20 and 21. As previously mentioned, the frame 16 of the snowmobile 10 includes the tunnel 18, the engine cradle 20, the front suspension module 22, and the upper structure 24. The implementation of the frame 16 shown in FIGS. 14, 15 and 20 is generally similar to the implementation of the frame 16 shown in FIGS. 2A to 2D. The differences between the rear legs 350 of FIGS. 14 to 21 and the rear legs 150 of FIGS. 2A to 2D will be discussed in detail below. As such all other features of the implementation of the frame 16 in FIGS. 14, 15 and 20 have been labeled with the same reference numbers as in FIGS. 2A to 2D. Some of the differences between corresponding features of the frame 16 of FIGS. 14, 15 and 20 and the frame 16 of FIGS. 2A to 2D will be pointed out throughout the description where relevant.

As best seen in FIGS. 2D and 20, the tunnel 18 generally forms an inverted U-shaped structure when viewed from the front or back. With reference to FIGS. 2A to 2D, the tunnel 18 includes a top wall 120 extending generally horizontally, a left side wall 122 extending generally vertically and a right side wall 122 extending generally vertically. A left bevel wall 124 connects the left edge of the top wall 120 to the upper edge of the left side wall 122. A right bevel wall 124 connects the right edge of the top wall 120 to the upper edge of the right side wall 122. Each bevel wall 124 is planar and extends downwardly and laterally outwardly from the horizontal top wall 120 to the corresponding vertical side wall 122. Each bevel wall 124 forms an obtuse angle with the horizontal top wall 120. Each bevel wall 124 also forms an obtuse angle with the corresponding vertical side wall 122. Each bevel wall 124 allows for connection of a corresponding upper rear support leg 150 as will be described further below. A portion 125 is connected to each side tunnel wall 122 just below the bevel 124 for aesthetic purposes. It is however contemplated that the portion 125 could also be used to support the upper rear support leg 150. It is contemplated that the portion 125 could be omitted as in the implementation of the tunnel 18 shown in FIGS. 14 and 15. The tunnel 18 of FIGS. 14 and 15 instead has four trapezoidal openings 302. It is contemplated that the openings 302 could be omitted, configured differently than as shown herein and/or that the tunnel 18 could have fewer or more than four openings 302. It is also contemplated that the tunnel 18 could have one or more openings 302 as well as the portion 125.

As best seen in FIGS. 2A, 14 and 15, when viewed from a lateral side, the top wall 120 slopes gently upwardly from the front to the rear of the tunnel 18. It is contemplated that the entire length of the top wall 120 could be horizontal, or that there could be more than one slope along the length of the tunnel 18. It is also contemplated that a portion of the top wall 120 could be curved in a lateral or longitudinal direc-

tion. With reference to FIGS. 2B to 2D, the top wall 120 has a rectangular gap 121 extending longitudinally along the centerplane 13. The gap 121 extends from the rear end of the tunnel 18 towards the front end of the tunnel 18. It is contemplated that the gap 121 could be shaped and sized differently than as shown. The heat exchanger 25 is disposed in the gap 121 of the top wall 120. The coolant flowing through the heat exchanger 25 is cooled by cool air flowing along the upper surface of the heat exchanger 25 disposed in the gap 121 and the snow being thrown upwards onto the lower surface of the heat exchanger 25 by the track 40 disposed below the tunnel 18.

With reference to FIGS. 2A to 2C, 14, 15 and 20, a central horizontal arm 90a of the bumper 90 is disposed above the top tunnel wall 120 at a rear thereof and the heat exchanger 25. A left end of the horizontal arm 90a is connected to a downwardly and forwardly extending left arm 90b and its right end connected to a downwardly and forwardly extending right arm 90b. The left arm 90b extends downwardly and forwardly along the leftwardly facing (outer) surface of the left tunnel wall 122 to its bottom edge and then bends forward to extend along the outer surface of the left tunnel wall 122 just above the bottom edge thereof. The front end of the left arm 90b is disposed forward of the rear end of the left footrest 64. The front end of the left arm 90b is fastened to the left tunnel wall 122 by a fastener 146 (FIG. 20). The fastener 146 also connects a rear suspension attachment bracket 142 to the left tunnel wall 122 as can be seen in FIG. 20. The rear suspension attachment bracket 142 connects the rear suspension assembly 32 to the tunnel 18. The rear suspension attachment bracket 142 has a vertically extending plate 143 disposed against the rightwardly facing (inner) surface of the left tunnel wall 122. The fastener 146, in the form of a bolt, is inserted through the vertical plate 143, and the left tunnel wall 122 into the left arm 90b of the bumper 90. The vertical plate 143 extends lower than the bottom edge of the left tunnel wall 122. One of the idler wheels 36 is rotatably connected to the lower end of the rear suspension attachment bracket 142 as can be seen in FIG. 1. It is contemplated that an element other than the idler wheel 36 of the rear suspension assembly 32 could be connected to the rear suspension attachment bracket 142 in addition to, or instead of the idler wheel 36 as shown herein. The rear suspension attachment bracket 142 also includes a horizontally extending plate 144 extending laterally outwardly from a middle portion of the attachment bracket 142. The horizontal plate 144 is formed integrally with the vertical plate 143 and disposed just below the bottom edge of the left tunnel wall 122. The right tunnel wall 122 similarly has a right rear suspension attachment bracket 142 fastened to the inner surface by a fastener 146 with an idler wheel 36 being connected to the lower end of the rear suspension attachment bracket 142. Although not seen in the figures, the right arm 90b similarly extends downwardly and forwardly along the right tunnel wall 122 to its bottom edge, and then bends forward to extend along the bottom edge of the right tunnel wall 122. The front end of the right arm 90b is disposed forward of the rear end of the right footrest 64. As can be seen in FIG. 17, the front end of the right arm 90b is fastened to the right tunnel wall 122 and the right rear suspension attachment bracket 142 by the fastener 146 as described above for the front end of the left arm 90b.

With reference to FIGS. 2A, 2B, 14 and 15, a front portion of the left side wall 122 of the tunnel 18 has an opening 126 which receives the front drive axle 35. The front portion of the left side wall 122 around the opening 126 is reinforced for additional rigidity, as can be seen when viewed from a

lateral side. The left footrest **64** extends leftwardly from the bottom edge of the left side wall **122**, and the right footrest **64** extends rightwardly from the bottom edge of the right side wall **122**. In some implementations of the tunnel **18**, the entire length of the footrest **64** is formed integrally with the tunnel side surfaces **122**. In the implementation of the tunnel **18** shown in FIGS. **2A** to **2C**, **14** and **15**, a front portion **128** of each footrest **64** is formed integrally with the corresponding side wall **122**. A toehold **66** extends upward from the front edge of each footrest **64**. Each of the left and right toeholds **66** has a generally vertical front portion **66a** that extends upwardly from the front edge of the footrest **64**, a generally horizontal middle portion **66b** that extends rearwardly from the top of the front portion **66a** and a rear portion **66c** that extends upwardly from the rear end of the middle portion **66b**. A footrest support **62** connects the front end of each footrest **64** to a rear portion **130** of the engine cradle **20**. In the implementation of the footrest **64** shown in FIGS. **14**, **15**, and **21**, a rear end of the left footrest **64** is fastened to the horizontal plate **144** of the left rear suspension attachment bracket **142** and a rear end of the right footrest **64** is fastened to the horizontal plate **144** of the right rear suspension attachment bracket **142**. The footrest **64** will be described in more detail below.

With reference to FIGS. **2A** to **2C**, the engine cradle **20** is attached to the front end of the tunnel **18** and extends forwardly therefrom. In the illustrated implementation of the engine cradle **20**, the rear portion **130** of the engine cradle **20** extends generally vertically and is connected to the front of the tunnel **18**. A generally horizontal bottom portion **132** of the engine cradle **20** extends forwardly from the bottom of the rear portion **130**, and a generally vertical front portion **134** rises upwards from the bottom portion **132** of the engine cradle **20**. The motor **50** is supported by the engine cradle **20** in a manner which would be determined by the size and shape of the motor **50**. Engine cradles having different shapes and including components different than as described above are also contemplated. The motor **50** can be supported on the bottom portion **132** of the engine cradle **20** or can also be solely and/or simultaneously supported by other areas of the engine cradle **20**, tunnel **18** and/or front suspension module **22**. On the right side of the engine cradle **20**, as best seen in FIGS. **2A** and **2C**, a generally horizontal upper bar **136** extends between the upper ends of the front and rear portions **134**, **130** of the engine cradle **20**. The upper bar **136** is spaced from the generally horizontal bottom portion **132** in order to provide additional structural rigidity to the engine cradle **20**. In the illustrated implementation, although not shown for clarity, an upper bar is also provided on the left side of the engine cradle **20** connecting the front and rear portion **134**, **130** and being spaced from the bottom portion **132**. It is contemplated that the engine cradle **20** could be configured differently than as shown herein.

With reference to FIGS. **2A** to **2C**, **14** and **15**, the front suspension module **22**, which attaches the front suspension assembly **16** to the snowmobile **10**, is attached to the front portion **134** of the engine cradle **20**. The front suspension module **22** extends forwardly from the engine cradle **20**. The front suspension module **22** includes left and right front suspension mounting brackets **140**. Each bracket **140** forms an inverted generally V-shaped structure extending forwardly from the front portion **134** of the engine cradle **20**. The corresponding front suspension assembly **72** is attached to each front suspension mounting bracket **140**. Other types of suspension mounting brackets are also contemplated to accommodate a different type of front suspension assembly

72. The front suspension module **22** and the engine cradle **20** also support a portion of an exhaust system (not shown) connected to the engine **50**.

With reference to FIGS. **2A** to **2D**, **14** and **15**, the upper support structure **24** includes an upper front support **102**, an upper column **103**, and an upper rear support **104**. The upper front support **102** includes left and right front support braces **108**. The lower end of each of the left and right front support braces **108** is attached to the corresponding one of the left and right front suspension mounting bracket **140** at its upper end (apex of the inverted V-shaped bracket **140**). A laterally extending frame member **107** connects between the lower ends of the two front support braces **108**. The frame member **107** is also connected to the top of the front suspension mounting brackets **140**. The apex of the left mounting bracket **140**, the left end of the frame member **107** and the bottom end of the left front support brace **108** are connected together at a common connection point **141** on the left side. Similarly, the apex of the right mounting bracket **140**, the right end of the frame member **107** and the bottom end of the right front support brace **108** are connected together at a common connection point **141** on the right side. Each front support brace **108** extends upwards, rearwards and laterally inwards to a steering bracket **148** positioned above the engine cradle **20**. The steering column **82** is rotatably inserted through the steering bracket **148** between the braces **108**. The steering column **82** extends downwards and forwards from the handlebar **84** through the steering bracket **148** to the front suspension assembly **72** (connection not shown in figures) for rotating the skis **70** and steering the snowmobile **10**. In the implementation of the frame **16** shown in FIGS. **14** and **15**, the steering bracket **148** does not extend as far forwardly of the upper end of the braces **108** as the steering bracket **148** of the frame **16** in FIGS. **2A** to **2D**. The steering bracket **148** of FIGS. **14** and **15** also does not extend as far forwardly of the upper end of the braces **108** as steering bracket **148** of FIGS. **2A** to **2D**. The front support braces **108** are formed as extruded hollow tubes made of metal or other suitably strong materials, however, the disclosure is not intended to be limited to this particular material, assembly method or configuration. For example, it is contemplated that the forward support braces **108** could have a different cross-section or be made by molding or casting. It is also contemplated that the forward support braces **106** may be constructed according to a monocoque or pseudo-monocoque technique instead of having a tubular construction as in the illustrated implementation.

With reference to FIGS. **2A** to **2C**, **14** and **15**, an upper column **103** connects the forward support braces **108** to the engine cradle **20**. The upper column **103** includes a left leg **118** and a right leg **118**. The upper end of the left leg **118** is connected to the left front support brace **108** just below the upper end of the left front support brace **108** which is connected to the steering bracket **148**. From the left front support brace **108**, the left leg **118** extends downwardly, rearwardly and leftwardly to the upper left hand corner of the engine cradle rear portion **130**. The upper end of the right leg **118** is similarly connected to the right front support brace **108** just below the upper end of the right front support brace **108** which is connected to the steering bracket **148**. From the right front support brace **108**, the right leg **118** extends downwardly, rearwardly and rightwardly to the upper right hand corner of the engine cradle rear portion **130**. In the illustrated implementation, each of the upper column legs **118** is in the form of a straight, tubular rod, but it is contemplated that the legs **118** could also have a bend or a curve. For example, each leg **118** could extend upwardly

from the engine cradle **20** and then laterally inwardly to the steering bracket **148**. It is also contemplated that the legs **118** could not be tubular, for example, the legs **118** could be in the form of a solid rod. It is further contemplated that the upper column could be constructed as a single inverted U-shaped structure having two legs **118**.

The upper rear support **104** will now be described with reference to FIGS. **3** to **5B**. The upper rear support **104** includes a pair of rear support legs **150**, referred to hereinafter as legs **150**, for convenience. The left leg **150** is similar to a mirror image of the right leg **150** and as such, corresponding features of the left and right legs **150** have been labelled with the same reference numbers, and only the left leg **150** will be described herein.

As can be seen in FIG. **3**, the leg **150** has an upper end **152** and a lower end **154**. With reference to FIG. **2A**, the upper end **152** of the leg **150** is disposed longitudinally rearward of the upper end of the upper column leg **118** and longitudinally forward of the lower end thereof. The upper end **152** is connected to the steering bracket **148**. The lower end **154** is connected to the bevel wall **124** in a middle portion of the tunnel **18** between the front and rear ends of the tunnel **18**. The fuel tank **52** and seat **60** are connected to a middle portion of the legs **150** between the upper and lower ends, **152** and **154**, thereof as can be seen in the implementation of the leg **350** shown in FIGS. **14** and **15**. The connection of the seat **60** and fuel tank **52** will be described below in further detail with respect to FIGS. **14** to **19B**.

With reference to FIGS. **4A** to **4C**, between the upper and lower ends **152** and **154**, the leg **150** has a C-shaped cross-section with an open channel **160** facing laterally inwardly towards the opposite (right) leg **150**. The channel **160** is defined by a front wall **157**, a side wall **158**, and a rear wall **159**. A left side portion of the fuel tank **52** is disposed in the channel **160** as can be seen in the implementation of the leg **350** shown in FIGS. **14** to **20**. The leg **350**, and the connection thereto of the fuel tank **52** and seat **60** will be described below in further detail.

With reference to FIG. **3**, the side wall **158** is generally planar below the upper end **152**. The side wall **158** extends generally longitudinally between a front edge **158a** and a rear edge **158b**. The side wall **158** has a lower edge **158d** which extends from the front edge **158a** to its rear edge **158b**. The lower edge **158d** is disposed generally parallel to the top wall **120** of the tunnel **18** when the rear leg **150** is mounted to the tunnel **18**. A through-hole **166** is defined in a recess **180** disposed near the front corner of the side wall **158** between the front edge **158a** and the lower edge **158d**. Another through-hole **168** is defined in a recess **190** disposed near the rear corner of the side wall **158** between the rear edge **158b** and the lower edge **158d**. Bolts **186**, **188** are respectively inserted through the holes **166**, **168** to connect the side wall **158** to the bevel wall **124** of the tunnel **18** as can be seen in FIG. **2A**. The angle, with respect to the vertical, of the bevel wall **124** of the tunnel **18** generally corresponds to the inclination angle of the side wall **158**, with respect to the vertical. The side wall **158** can thus be directly fastened to the bevel wall **124** without using any additional brackets. The recesses **180**, **190** and the connection of the leg **350** to the bevel wall **124** will be described further below with respect to the implementation of the leg **350** shown in FIGS. **14**, **15** and **17**.

With reference to FIG. **3**, a number of apertures **156** are defined in the middle portion of the side wall **158** to reduce the weight of the leg **150**. The apertures **156** are formed by punching the side wall **158**. The side wall **158** bends laterally inwardly around the edges of each aperture **156** as can be

seen in FIG. **4C** to form a flange around the aperture **156**. The flanged apertures **156** increase the rigidity of the leg **150**.

With reference to FIG. **3**, the side wall **158** tapers towards the upper end **152**. The front and rear edges **158a**, **158b** of the side wall **158** define a side wall width **162** therebetween. The side wall width **162** is measured perpendicular to a centerline **153** of the side wall **158**. As the side wall **158** extends downwardly from its upper end **152**, its front edge **158a** moves further away from its rear edge **158b**. The side wall width **162** thus increases from the upper end **152** towards its lower edge **158d**. The rear edge **158b** is linear while the front edge **158a** is linear above and below a bend **165** near the lower end **154**. Below the bend **165**, the front edge **158a** moves further away from the rear edge **158b** such that the side wall width **162** increases abruptly at the bend **165**.

With reference to FIGS. **3** to **4C**, the front wall **157** extends laterally inwardly from the front edge **158a** of the side wall **158** to an inner edge **157a**. The front wall **157** has a lower edge **157d** that is spaced from the side wall lower edge **158d**. As best seen in FIG. **2A**, the front wall lower edge **157d** is adjacent the top wall **120** of the tunnel **18**. The front wall **157** has a bend **167** (FIG. **3**) connected to the bend **165** of the side wall front edge **158a**. The front wall **157** is generally planar above the bend **167**. It is contemplated that the entire length of the front wall **157** could be planar.

With reference to FIGS. **3** to **4C**, the rear wall **159** extends laterally inwardly from the rear edge **158a** of the side wall **158** to an inner edge **159a**. The rear wall **159** is also generally planar between the upper and lower ends **152**, **154**. The rear wall **159** has a lower edge **159d** that is spaced from the lower edge **158d** of the side wall **158**. As best seen in FIG. **2A**, the rear wall lower edge **159d** is adjacent the top wall **120** of the tunnel **18**.

With reference to FIGS. **4A** to **4C**, the front wall **157** and the rear wall **159** extend from the side wall **158** at an obtuse angle but it is also contemplated that the front and rear walls **157**, **159** could be perpendicular to the side wall **158**. A width **164** of the leg **150** can be defined between the inner edge **157a** of the front wall **157** and the inner edge **159a** of the rear wall **159** and measured in a plane perpendicular to the side wall **158** in a direction perpendicular to the centerline **153**. The leg width **164** also increases from its upper end **152** towards its lower end **154**.

With reference to FIGS. **2C**, **5A** and **5B**, the leg **150** extends generally vertically and longitudinally in the upper end **152** but does not extend laterally inwardly. It is contemplated that the upper end of the leg **150** could also extend laterally inwardly. The longitudinally extending surface in the upper end **152** is also recessed in a laterally inward direction. A pair of through-holes **161** is defined in the upper end **152**. Bolts (not shown) are inserted into the through-holes **161** for fastening the steering bracket **148** to the leg **150**. It is contemplated that the upper end **152** could be structured differently than as shown herein.

Another implementation of an upper rear support **104** having legs **150'** will now be described with reference to FIGS. **6** to **7C**. The left leg **150'** is similar to a mirror image of the right leg (not shown) and as such only the left leg **150'** is shown and described herein. In addition, the left leg **150'** is similar to the left leg **150** described above. Corresponding features of the legs **150**, **150'** have been labeled with the same reference numbers and will only be discussed herein with respect to their differences.

With reference to FIG. 6, the left leg 150' has an upper end 152 and a lower end 154, a front wall 157, a rear wall 159 and a side wall 158 extending therebetween.

The side wall 158 of the leg 150' is generally similar to the side wall 158 of the leg 150 except that the apertures 156 have been omitted from the leg 150' and a shallow elongated recess 155 has been added to the side wall 158 of the leg 150'. The elongated recess 155 extends upwards from the lower end 154 to a middle portion of the side wall 158. The recess 155 is disposed closer to the front edge 158a than to the rear edge 158b but it is contemplated that the recess 155 could be centered between the edges 158a, 158b or disposed closer to the rear edge 158b. The elongated recess 155 has a uniform width except for a wider portion disposed closer to the lower end 154. The shape and size of the recess 155 could be different than as shown herein. The recess 155 could be formed as multiple recesses, and/or additional recesses could also be provided in a different location along the side wall 158.

With reference to FIGS. 6 to 7C, the front wall 157 of the leg 150' has a first planar portion 177 extending laterally inwardly from the front edge 158a and a second planar portion 172 extending laterally inwardly from the first planar portion 177 to a laterally inner edge 157a of the front wall 157. The first planar portion 177 is disposed at an obtuse angle with respect to the planar side wall 158 and the second planar portion 172 is disposed generally perpendicular to the planar side wall 158. The first planar portion 177 therefore forms an angled front bevel wall 177 of the rear leg 150'. The rear wall 159 similarly has a first planar portion 179 extending laterally inwardly from the rear edge 158b and a second planar portion 174 extending laterally inwardly from the first planar portion 179 to a laterally inner edge 159a of the rear wall 159. The first planar portion 179 is disposed at an obtuse angle with respect to the planar side wall 158 and the second planar portion 174 is disposed generally perpendicular to the planar side wall 158. The first planar portion 179 therefore forms an angled rear bevel wall 177 of the rear leg 150'. It is contemplated that the front and rear bevel walls 177, 179 could each be disposed at a different angle with respect to the planar side wall 158 than as shown herein. It is also contemplated that either or both of the first planar portions 177, 179 could not be disposed generally perpendicular to the side wall 158.

Thus, the leg 150' of FIGS. 6 to 7C also has a generally C-shaped cross-section, but the C-shaped cross-section is formed by five generally planar surfaces 172, 177, 158, 179, and 174 instead of three generally planar surfaces 157, 158, and 159 as in the leg 150 of FIGS. 3 and 4. As the shape of the channel 160 defined by the rear leg 150' is slightly different from that of the channel 160 defined by the rear leg 150, the fuel tank (not shown) used with the rear leg 150' has a side portion disposed in the channel 160 and congruous with the inward facing surfaces of the walls 172, 177, 158, 179, 174 that is slightly different from the side portion of the fuel tank 52 used with the implementation of the rear leg 150.

With reference to FIGS. 6 to 7C, a leg width 164 can also be defined for the leg 150'. The leg width 164 is measured between the laterally inner edge 157a of the front wall 157 and the laterally inner edge 159a of the rear wall 159 in a plane perpendicular to both walls 157, 159. The leg width 164 increases from the upper end 152 toward the lower end 154.

The upper rear support 104 of FIGS. 14 and 15 has another implementation of legs 350 which will now be described with reference to FIGS. 14 to 21.

The left leg 350 is generally a mirror image of the right leg 350 (FIG. 21), and as such only the left leg 350 is described herein. In addition, the left leg 350 is similar to the left leg 150' described above. As such, features of the leg 350 have been labeled with the same reference numbers as the corresponding features of the leg 150', except that the first digits of the reference number have each been changed from "1" to "3". The left leg 350 will only be described herein in detail with respect to some of the differences with the left leg 150' discussed above.

With reference to FIG. 14, the upper end 352 of the leg 350 is generally longitudinally aligned with the upper end of the upper column leg 118 and is disposed longitudinally forwardly of the lower end thereof. The leg 350 is connected to the steering bracket 148 by two bolts (not shown) inserted through through-holes 361 (FIG. 18) defined in the upper end 352.

A bracket 376 extends downwardly from the edge 157a of the front wall 157. The bracket 376 is generally triangular in shape and disposed in the middle portion of the leg 350, closer to the lower end 354 than to the upper end 352. The bracket 376 has a through-hole 378 formed therein and is used to connect a panel (not shown) of the fairings 94 to the left leg 350.

The lower end 354 of the leg 350 is connected to the bevel surface 124 in a middle portion of the tunnel 18 between the front and rear ends of the tunnel 18. In the lower end 354, the side wall 358 has a recess 380 (similar to the recess 180 of the legs 150, 150') disposed near the front corner defined by the front edge 358a and the lower edge 358d, and a recess 390 (similar to the recess 190 of the legs 150, 150') disposed near the rear corner defined by the rear edge 358b and the lower edge 358d.

With reference to FIG. 19A, the recess 380 is circular and defined by a planar inner wall 384 and a cylindrical peripheral wall 382. The inner wall 384 is spaced from the planar side wall 358 and disposed laterally inwardly thereof. The inner wall 384 extends generally parallel to the planar portion of the side wall 358.

The peripheral wall 382 extends laterally outwardly from the edge of the inner wall 384 to the planar portion of the side wall 358. A through-hole 366 is defined in the inner wall 384 of the recess 380. A bolt 386 is inserted through the hole 366 to fasten the leg 350 to the bevel surface 124 of the tunnel 18 as can be seen in FIG. 17.

The recess 390 is similarly circular and defined by a planar inner wall 394 and a cylindrical peripheral wall 392. The inner wall 394 is spaced from the planar side wall 358 and disposed laterally inwardly thereof. The inner wall 394 extends generally parallel to the planar portion of the side wall 358. The peripheral wall 392 extends laterally outwardly from the edge of the inner wall 394 to the planar portion of the side wall 358. A through-hole 368 is defined in the planar wall 394 of the recess 390. A bolt 388 is inserted through the hole 368 to fasten the leg 350 to the bevel surface 124 of the tunnel 18 as can be seen in FIG. 17.

As can be seen in FIG. 17, when the leg 350 is mounted to the tunnel 18, the bevel surface 124 is in contact with the planar inner recess walls 384, 394 and spaced from the planar portions of the side wall 358 in the lower end 354. In the illustrated implementation, the planar side wall 358 along the entire length of the leg 350 below the upper end 352 extends generally parallel to the bevel surface 124. It is contemplated that the planar side wall 358 could not be parallel to the inner recess walls 384, 394 and the bevel surface 124.

As can be seen in FIG. 17, below the top surface 120 of the tunnel 18, inner edges 357a and 359a of the walls 357 and 359 extend laterally inwards from the side wall 358 towards the bevel wall 124. In the illustrated implementation, the bevel wall 124 does not contact the edges 357a, 359a of the front and rear wall 357, 359. It is contemplated that the edges 357a, 359a could contact the bevel wall 124. Above the top wall 120 of the tunnel 16, the edges 357a, 359a of the front and rear walls 357, 359 are spaced further from the side wall 358 than they are below the top wall 120. As can be seen in FIG. 21, above the tunnel 18, the inner edge 357a is disposed laterally inwardly of a left bevel plane 480 containing the left bevel wall 124. The left bevel plane 480 intersects the front and rear walls 357, 358 of the left leg 350 above the tunnel 18 such that the side wall 358 is disposed on an opposite of the left bevel plane 480 than the inner edges 357a, 359a. Although not shown for the leg 350, a right bevel plane 480 (FIG. 2D) containing the right bevel wall 124 similarly intersects the front and rear walls 357, 358 of the right leg 350 above the tunnel 18.

As can be seen in FIG. 2D, the left bevel plane 480 also intersects the front and rear walls 157, 159 of the left leg 150 above the tunnel 18 such that the side wall 158 is disposed on an opposite of the right bevel plane 480 than the inner edges 157a, 159a of the left leg 150. The right bevel plane 480 similarly intersects the front and rear walls 157, 159 of the right leg 150 above the tunnel 18 such that the side wall 158 is disposed on an opposite of the right bevel plane 480 than the inner edges 157a, 159a. The inner edges 157a, 159a are disposed laterally inwardly of the corresponding one of the left and right bevel plane 480. As can be seen in FIG. 2D, the intersection of the left bevel plane 480 with the rear wall 159 of the left leg 150 extends along the entire length of the left leg 150 above the tunnel 18. Although not shown, the intersection of the right bevel plane 480 with the front wall 157 extends along the entire length of the left leg 150 above the tunnel 18. Although not shown, the intersection of the left bevel plane 480 with the front wall 157 extends along the entire length of the left leg 150 above the tunnel 18. Similarly, the intersection of the right bevel plane 480 with the front and rear walls 157, 159 extends along the entire length of the right leg 150 above the tunnel 18. It is contemplated that the intersection of each of the left and right bevel walls 480 with the front and rear walls 157, 159 could extend along only a portion of the corresponding leg 150 above the tunnel 18.

With reference to FIGS. 14 and 15, the planar side wall 358 has an elongated recess 355 extending between the front and rear edges, 358a and 358b, and between the upper and lower ends, 352 and 354. The upper end of the recess 355 is disposed just below the upper end 352 of the leg 350 and the lower end of the recess 355 is disposed just above the lower end 354. The recess 355 has a wider portion 400 which has a through-hole 402 defined therein. The wider portion 400 is disposed slightly higher than the bracket 376 of the leg 350.

With reference to FIGS. 15 to 16A, a fastener 404 is inserted through the through-hole 402 into the fuel tank 52 to fasten the fuel tank 52 to the leg 350. The fastener 404 is in the form of a bolt having a bolt head 406 connected to a threaded shank 408 extending laterally inwardly through the hole 402 into the fuel tank 52. On the side opposite the threaded shank 408, the bolt head 406 has a projection 410 extending laterally outwardly from a laterally outer surface (the surface opposite the threaded shank 408) of the bolt head 406 to a spherical outer end 412.

With reference to FIGS. 14 to 16B, the fuel tank 52 has a body 420 having a left side portion 422 and a right side

portion 422. The left side portion 422 is complementary to the channel 360 of the left leg 350 and received therein. The right side portion 421 is complementary to the channel 360 of the right leg 350 and received therein. The channel 360 of each leg 350 encloses the corresponding side portion 422 of the fuel tank body 420. The fuel tank body 422 has recessed portions that receive the front and rear walls 357, 359 extend laterally inwardly away from the side wall 358. In the illustrated implementation, the longitudinal walls 357, 358, 359 of the leg 350 are spaced from the outer surface of the corresponding side portion 422 (see FIGS. 16A and 16B) except in the wider recess portion 400 (see FIG. 16A). It is contemplated that the portions of the leg 350 other than in the wider recess portion 400 could be in contact with the outer surface of the side portion 422 of the fuel tank body 420. A metal insert 424 is molded into the left side portion 422 aligned with the wider recess portion 400. The insert 424 has an internally threaded elongated opening 426 which engages the threaded shank 408 of the fastener 404 to thereby fasten the fuel tank 52 to the left leg 350. The right side portion 422 similarly has a metal insert 424 with an internally threaded opening 426 engaging a right fastener 404 to fasten the right side of the fuel tank 52 to the right leg 350.

The seat 60 has a left side portion 430 disposed on the laterally outwardly facing surface of the side wall 358 such that the leg 350 is disposed between the left side portion 430 of the seat 60 and the left side portion 422 of the fuel tank body 420. The spherical outer end 412 of the projection 410 is received in a complementary slot 432 formed in a surface of the left side portion 430 facing laterally inwardly towards the leg 350 and the spherical outer end 412. The slot 432 engages the spherical outer end 412 of the fastener 404 to fasten the seat 60 to the left leg 350. The right fastener 404 also has a spherical outer end 412 which is similarly engaged by a slot 432 formed in a laterally inwardly facing surface of the right side portion 430 of the seat 60 to fasten the seat 60 to the right leg 350.

In all implementations of the leg 150, 150', 350 discussed above, the entire left leg 150, 150', 350 including the upper end 152, 352 connected to the steering bracket 148 and the lower end 154, 354 connected to the tunnel 18, is formed as a single integral structure. The left leg 150, 150', 350 is formed from a single piece of sheet metal structure that is bent to create the structure described above. The various apertures 156, 166, 168, 161 and recesses 155, 180, 190 are created by punching, stamping, or drilling, which can be done either before or after bending the sheet metal.

Forming the entire leg 150, 150', 350 out of a single piece of sheet metal allows the upper end 152, 352 and the lower end 154, 354 of the leg 150, 150', 350 to be connected to other vehicle portions (steering bracket 148 and tunnel 18 respectively) directly without the need for using separate attachment brackets as in the case of tubular braces such as the front support braces 108. With tubular braces, casted end portions are welded to the respective upper and lower ends of the tubes to allow their respective attachment to the steering bracket 148 and to the tunnel 18.

Connecting the leg 150, 150', 350 directly to the other snowmobile portions without using additional brackets helps to reduce the overall weight of the snowmobile 10, and also to reduce complexity and cost in the fabrication and assembly thereof.

As mentioned above, the side wall 158, 358 below the upper end 152, 352 is flat and constructed without any bends in it. This flat, planar structure of the side wall 158 helps to reduce the risks of developing cracks or breaks at the

location of the bend, especially in legs made of materials such as aluminum which have less fatigue strength than steel.

In addition, having the front wall **157, 357** and rear wall **159, 359** being angled with respect to the side wall **158, 358** and extending from the side wall **158, 358** along the entire length thereof below the upper end **152, 352** helps to increase the inertial strength and rigidity of the legs **150, 150', 350**. The legs **150, 150', 350** described above, having front **157, 357**, side **158, 358** and rear walls **159, 359** made of bent sheet metal, provide greater strength and resistance to forces of compression and torsion than an unbent sheet metal structure.

The footrests **64** will now be described in further detail with reference to FIGS. **2B, 2C**, and **8 to 12**.

With reference to FIGS. **2B, 2C** and **8 to 12**, the left footrest **64** is similar to a mirror image of the right footrest **64**, and as such only the left footrest **64** will be described herein in detail. It is contemplated that the left and right footrests **64** could not be mirror images of each other.

With reference to FIGS. **8 to 10**, the left footrest **64** includes a grid structure **201** formed of interconnected ribs **202, 204** defining large holes **203** therebetween. The ribs **202, 204** include longitudinal ribs **202** and lateral ribs **204**. The longitudinal ribs **202** extend in a longitudinal direction and the lateral ribs **204** extend in a lateral direction generally perpendicular to the longitudinal ribs **204**. It is contemplated that the ribs **202** could extend in a direction other than longitudinal, the ribs **204** could extend in a direction other than lateral (as in the implementation of the footrest **364** shown in FIGS. **14, 15** and **21 to 24**), and that the ribs **202** could not extend in a direction perpendicular to the ribs **204**. Consecutive longitudinal ribs **202** are connected to each other by lateral ribs **204** extending therebetween in a lateral direction. When the snowmobile **10** is traveling on soft snow and the footrests **64** begin to contact the snow, the large holes **203** help to reduce jacking by allowing snow to pass upwardly therethrough. In addition, the large holes **203** are helpful for clearing snow off the footrests **64** by allowing the snow to fall therethrough. This grid structure **201** of the footrest **64** with interconnected longitudinal and lateral ribs **202, 204** separated by large holes **203** reduces the weight of the snowmobile **10** without compromising the rigidity and strength of the footrest **64**.

With reference to FIGS. **8 to 10**, the left footrest **64** has three longitudinal ribs **202**, including a left rib **202**, a middle rib **202** and a right rib **202**, each extending in the longitudinal direction. It is contemplated that there could be more or less than three longitudinal ribs **202**. In the illustrated implementation of the footrest **64**, the longitudinal ribs **202** are also equally spaced from one another in the lateral direction. It is also contemplated that the longitudinal ribs **202** could not be equally spaced from one another in the lateral direction. The front edges of all three longitudinal ribs **202** are connected together by a forwardmost lateral rib **240**. The longitudinal ribs **202** extend rearward from the forwardmost lateral rib **240**. The right longitudinal rib **202** extends farther rearward than the middle longitudinal rib **202**, which in turn extends farther rearward than the left longitudinal rib **202**. The left footrest **64** is thus tapered towards the rear. It is contemplated that the longitudinal ribs **202** could be configured differently than as shown herein.

As best seen in FIGS. **2C** and **8 to 10**, the lateral ribs **204** are also disposed parallel to one another when viewed from above. The lateral ribs **204** extend generally perpendicular to the longitudinal ribs **202** and normal to the longitudinal centerplane **13**. As mentioned above, it is contemplated that

the lateral ribs **204** could extend at an angle other than perpendicular with respect to the longitudinal ribs **202** and/or the longitudinal centerplane **13**.

With reference to FIGS. **8 to 11B**, each lateral rib **204** has a planar upper surface **204a**, a planar lower surface **204b**, a front surface **204c** and a rear surface **204d**. It is contemplated that the surfaces **204a, 204b** could not be planar. A lateral rib height **250** (FIGS. **11A** and **11B**) is defined between the upper and lower lateral rib surfaces **204a, 204b**. A lateral rib thickness **252** (FIG. **10**) is defined between the front and rear lateral rib surfaces **204c, 204d**.

With reference to FIGS. **8 to 11B**, each longitudinal rib **202** has an upper surface **202a**, a lower surface **202b**, a left surface **202c** and a right surface **202d**. A longitudinal rib thickness **260** (FIG. **11A**) is defined between the left and right longitudinal rib surfaces **204c, 204d**. A longitudinal rib height **262** (FIGS. **11A** and **11B**) is defined between the upper and lower longitudinal rib surfaces **202a, 202b**. The upper longitudinal rib surface **202a** is disposed vertically higher than the upper lateral rib surface **204a**. The lower longitudinal rib surface **202b** is disposed vertically lower than the lower lateral rib surface **204b**, by a vertical distance **264**. The longitudinal rib thickness **260** is smaller than the longitudinal rib height **262**. The longitudinal rib thickness **260** is also smaller than the height **264** of the portion of the longitudinal rib **202** disposed lower than the lower lateral rib surface **204b**. The portion of the longitudinal rib **202** disposed lower than the lower lateral rib surface **204b** thus acts like a blade that helps slice through the snow when the footrest **64** makes contact with the snow surface.

With reference to FIG. **10**, each hole **203** has a length **266** measured between two consecutive lateral ribs **204** in a direction parallel to the longitudinal ribs **202**. Each hole **203** has also has a width **268** measured between two consecutive longitudinal ribs **202** in a direction perpendicular to the longitudinal ribs **202**. As can be seen, all of the holes **203** in the illustrated implementation have the same width **268** but different lengths **266**.

With reference to FIGS. **8 to 11B**, the upper longitudinal rib surface **202a** has several teeth **206** projecting upwardly therefrom. The teeth **206** provide traction to the riders' foot disposed on the footrest **64**. Each tooth **206** extends above the upper longitudinal rib surface **202a** by a height **272** (FIG. **11A**). The height **272** of the teeth **206** is less than the extension **264** of the longitudinal rib **202** below the lower surface **204b** of the lateral rib **204**. It is contemplated that the number and configuration of the ribs **202, 204** could be different than that described herein.

With reference to FIGS. **8 to 12**, the footrest **64** has an inner mounting flange **210** for connecting the footrest **64** to the left side wall **122** of the tunnel **18**. The inner mounting flange **210** forms an inner edge of the footrest **64**. The inner mounting flange **210** is in the form of a plate extending longitudinally and vertically with an inner surface **210b** (FIGS. **11A** and **11B**) facing laterally inwardly and an outer surface **210a** facing laterally outwardly. The upper edge **210c** has several tabs **210d** extending upwardly therefrom. Some of the tabs **210d** have through-holes **212** defined therethrough. Bolts (not shown) are inserted through the through-holes **212** and through corresponding holes formed in the left side wall **122** of the tunnel **18** to connect the footrest **64** to the tunnel **18**. It is contemplated that other types of fasteners such as rivets, or self-piercing rivets could also be used to fasten the footrest **64** to the tunnel **18**. The front edge of the inner mounting flange **210** is connected to the forwardmost lateral rib **240**. Several other lateral ribs **204** extends leftwardly (laterally outwardly) from the outer

surface **210a** of the inner mounting flange **210** to the right longitudinal rib **202**. The inner mounting flange **210** extends farther rearward than the right longitudinal rib **202**. The inner mounting flange **210** is formed integrally with the lateral ribs **204**. It is contemplated that the inner mounting flange **210** could be connected to the ribs **202**, **204** without being integrally formed therewith.

As best seen in FIG. 12, the left footrest **64** has a bend **242** formed just rearward of the second row of lateral ribs **204**. The front portion of the left footrest **201** forward of the bend **242** is bent upwardly with respect to the portion rearward of the bend **242**.

With reference to FIGS. 2B and 2C, the left footrest **64** includes a front tunnel extension **128** disposed forward of the grid structure **201**. The front tunnel extension **128** extends laterally outwardly from the bottom edge of the left side wall **122**. As mentioned above, the front tunnel extension **128** is formed integrally with the tunnel **18** and has a plurality of holes **129**. The forwardmost lateral rib **204** is fastened to the rear end of the left tunnel extension **128** so as to form a continuous support for a rider's left foot. The toehold **66** extends upwardly from the front edge of the front tunnel extension **128**. The footrest support **62** is also connected to the left (laterally outer edge) of the front tunnel extension **128**.

With reference to FIGS. 2B and 2C, the left footrest **64** is also connected to the tunnel **18** by an outer mounting bracket **220** connected to the left side (laterally outer) edge of the left footrest **64** and a rear mounting bracket **230** connected to a rear edge of the outer mounting bracket **220**.

As can be seen in FIGS. 8 to 10, the outer mounting bracket **220** extends longitudinally and slightly laterally outwardly from its rear end to its front end. The outer mounting bracket **220** is in the form of a hollow tubular structure formed by extrusion. As best seen in FIGS. 8 and 9, the outer mounting bracket **220** of the illustrated implementation has a rectangular cross-section with a generally horizontal upper surface **220a** and a generally horizontal lower surface **220b** connected together by a pair of vertical surfaces **220c**. The upper surface **220a** of the outer mounting bracket **220** is ribbed and has teeth **222** projecting upwardly therefrom to provide traction to a rider's left foot. In the illustrated implementation, the outer mounting bracket **220** has three longitudinal rows of teeth **222** formed on its upper surface **220a**. It is however contemplated that there could be more or less than three rows of teeth **222**. A number of tabs **224** extending laterally inwardly from the vertically extending surface **220c** facing laterally inwardly toward the tunnel **18**. The tabs **224** have through-holes defined therethrough. The tabs **224** are connected to the lateral ribs **204** by bolts inserted through the holes of the outer mounting flange tabs **224** and through corresponding holes defined in the left edges of the later ribs **204** as best seen in FIG. 2C.

With reference to FIGS. 8 to 10, a front portion of the outer mounting bracket **220** extends forward of the forwardmost lateral rib **240**. The front portion of the outer mounting bracket **220** extends on a left side (laterally outer side) of the left front tunnel extension **128** and is fastened thereto by the tabs **224** to further secure the front portion of the footrest **64** to the tunnel **18**.

With reference to FIGS. 8 to 10, the rear mounting bracket **230** has a front portion **232** that extends generally longitudinally, and a rear portion **234** that extends upwardly and rearwardly from the front portion **232**. The rear mounting bracket **230** forms a C-shaped channel **236** that is open in a direction facing away from the tunnel **18**. The channel **236** extends in the front and rear portions **232**, **234** of the rear

mounting bracket **230**. The rear end of the outer mounting bracket **220** is received in the channel **236** in the front portion **232** such that the inner vertical surface **220c** of the outer mounting bracket **220** abuts against the inner channel wall of the rear mounting bracket **230**. The outer mounting bracket **220** is fastened to the rear mounting bracket **230** by rivets, or other fasteners, inserted through aligned through-holes **244** (FIG. 9) of the inner vertical surface **220c** of the outer mounting bracket **220** and the inner channel wall of the rear mounting bracket **230**. The inner channel wall of the rear portion **234** of the rear mounting bracket **230** abuts the left side wall **122** of the tunnel **18** and is fastened thereto by rivets, or other fasteners, inserted through aligned holes **246** (FIGS. 8 and 9) of the rear portion **234** and the left side tunnel wall **122**. The rear end of the outer mounting bracket **220** is thus secured to the tunnel **18** by the rear mounting bracket **230**. The rear portion **234** of the rear mounting bracket **230** also has three teeth **248** extending laterally outwardly from the edge of the laterally extending front surface to provide traction to a rider's foot. It is contemplated that there could be more or less than three teeth **248**.

As can be seen in FIGS. 2A to 2C, the left footrest **64** is thus secured to the tunnel **18** by its left (laterally outer) edge, its rear edge and its right (laterally inner) edge.

With reference to FIGS. 8 to 10, the hollow tubular structure of the outer mounting bracket **220** and the structure of the rear mounting bracket **230** having the open channel **236** help to reduce the weight of the vehicle **10**. It is contemplated that the mounting brackets **220**, **230** could be configured differently than as shown herein, and connected together differently than as shown herein. It is also contemplated that the rear mounting bracket **230** could be formed integrally with the outer mounting bracket **220**.

The various dimensions of the grid structure **201** in the footrest **64** are selected as described below to reduce jacking and increase trenching while still providing appropriate support to a rider's foot disposed on the footrest **64** and without causing any significant increase in the weight of the snowmobile **10**.

With reference to FIGS. 11A and 11B, in the illustrated implementation, a ratio **R1** of the extension **264** of the longitudinal rib **202** below the lateral rib surface **204b** to the longitudinal rib width **260** is selected to be greater than 1.5 and less than 5.5. In the illustrated implementation of the footrest **64** in FIGS. 8 to 12, the ratio **R1** is approximately 3.3.

A ratio **R2** of a hole width **268** measured in millimeters to the value of the ratio **R1** is selected to be greater than 5.0 and less than 15. In the illustrated implementation, the ratio **R2** is approximately 10.

A ratio **R3** of the hole width **268** to the extension **264** of the longitudinal rib **202** below the lateral rib surface **204b** is selected to be greater than 1.0 and less than 6.0. In the illustrated implementation, the ratio **R2** is approximately 3.0.

It has been noted that trenching can be increased and jacking can be reduced while still providing appropriate support to a rider's foot disposed on the footrest **64** and without causing any significant increase in the weight of the snowmobile **10** if the footrest **64** is configured such that the ratio **R1** is between 1.5 and 5.5, the ratio **R2** is between 5.0 and 15.0, and the ratio **R3** is between 1.0 and 6.0.

The footrest **64** is formed by a process that includes an initial extrusion step. The extrusion step forms a horizontally extending plate (not shown) with parallel ribs **202** and the mounting flange **210**. The ribs **202** extend above and below the horizontal plate while the mounting flange **210** extends

upward from an edge of the horizontal plate. The direction of extrusion defines the direction of the ribs **202** and the mounting plate. In the implementation of the footrest **64** shown herein, the ribs **202** are aligned with the longitudinal direction of the vehicle **10** (parallel to the longitudinal centerplane **13**) when the footrest **64** is connected to the vehicle **10**. It is however contemplated that the ribs **202** could extend at an angle to the longitudinal centerplane **13**. For convenience, the process of forming the footrest **64** is described herein referring to the direction defined by the ribs **202** as the longitudinal direction, but the present technology is not to be limited by the adoption of this terminology.

The lateral ribs **204**, and the holes **203** are then created by punching holes through the horizontal extruded plate between the parallel ribs **202**. It is contemplated that the lateral ribs **204** and holes **203** could be created by other methods. The punching step for forming the lateral ribs **204** and the holes **203** is performed by displacing the punch in a vertical direction with respect to the horizontal extrusion plate.

The teeth **206** on the upper surface of the longitudinal ribs **202** and the upward extensions **210d** of the inner mounting flange **210** are created by a separate punching step in which the punch is displaced laterally with respect to the longitudinal ribs **202** and the extrusion direction. The upward extensions **210d** of the mounting flange **210** could be created by a separate punching step, in which the punch is displaced laterally with respect to the longitudinal ribs **202** and the extrusion direction. It is also contemplated that the teeth **206** and the upward extensions **210d** could be created by a different process, such as machining. The upward bend **242** best seen in FIG. **12**, is created after the extrusion and the punching processes.

As mentioned above, the outer mounting bracket **220** is formed by extrusion. The rear mounting bracket **230** is formed by casting and/or stamping.

It is contemplated that the footrests **64** could be formed of any suitable materials and by processes other than as described herein.

With reference to FIGS. **14**, **15** and **21** to **24**, another implementation of footrests **64** will now be described. The footrests **364** of FIGS. **14**, **15** and **21** to **24** have many features similar to the corresponding features of footrests **64** of FIGS. **1** to **2D** and **8** to **12**. As such, features of the footrest **364** similar to the corresponding features of footrests **64** have been labeled with the same reference numbers and will not be described again herein. The footrest **364** will only be described herein in detail with respect to differences from the footrest **64**. The left footrest **364** is similar to a mirror image of the right footrest **364** and as such corresponding features of the left and right footrests **364** have been labeled with the same reference numbers and only the left footrest **364** will be described herein.

The left footrest **364** has a grid structure **201** formed of interconnected ribs **202**, **304** defining large holes **303** therebetween. The longitudinal ribs **202** extend in a longitudinal direction. The ribs **304** extend more in a lateral direction than a longitudinal direction, and are therefore referred to herein as lateral ribs **304**. Consecutive longitudinal ribs **202** are connected to each other by lateral ribs **204** extending therebetween. The lateral ribs **304** extend at a non-perpendicular angle to the longitudinal ribs **202**. It is contemplated that the ribs **202** could extend in a direction other than longitudinal. The holes **303** defined by the ribs **202**, **304** are therefore trapezoidal rather than rectangular in shape as in the footrests **64**.

With reference to FIGS. **22** to **24**, the footrest **364** includes several teeth **306** projecting upwardly from the grid structure **201** and extending vertically higher than the upper surface **204a** of the lateral ribs **304**. The teeth **306** provide traction to the riders' foot disposed on the footrest **364**. Each tooth **306** is laterally offset from a longitudinal rib **202** and connected thereto by a bridge portion **307** that extends laterally inwardly from the longitudinal rib **202**. Some of the teeth **306** are disposed between consecutive lateral ribs **304** while other teeth **306** extend upward from the upper surface **204a** of a lateral ribs **304**. The teeth **306** extend above the upper longitudinal rib surface **202a** by a height **272** (FIG. **11B**). The height **272** of the teeth **306** above the upper lateral rib surface **202a** is smaller than the extension **264** of the longitudinal rib **202** below the lower lateral rib surface **202b**. This configuration of the teeth **306** being offset from the longitudinal ribs **202** allows the teeth **306** to be formed in the same extrusion step as the longitudinal ribs **202** thereby eliminating the extra punching step required for forming the teeth **206** of the footrest **64**. This configuration of the teeth **306** therefore allows for a simplification in fabrication of the footrest **364** while still providing traction to a rider's foot disposed on the footrest **364**.

With reference to FIGS. **21** to **24**, the footrest **364** has a rear mounting bracket **330**. The rear mounting bracket **330** has an upper portion **332** and a lower portion **334**. An upper end **332a** of the upper portion **332** is connected to the left side wall **122** of the tunnel **18** by bolts inserted through aligned through-holes of the rear mounting bracket **330** and the left tunnel wall **122**. The upper portion **332** extends downwardly and laterally outwardly from the upper end **332a** thereof to a lower end **332b** thereof. The lower end **332b** of the rear mounting bracket upper portion **332** forms a channel (not shown) that is open towards the front of the snowmobile **10**. The rear end of the outer mounting bracket **220** is received in the channel of the lower end **332b** and fastened thereto. The rear end of the outer mounting bracket **220** is thus secured to the tunnel **18** by the rear mounting bracket **330**. The upper portion **332** two longitudinally and vertically extending walls **333** extending between the upper and lower ends, **332a** and **332b**. The front edge of the laterally outer wall **333** has six teeth **336** extending forwardly therefrom to provide traction to a riders foot. It is contemplated that there could be more or less than six teeth **336**. It is also contemplated that the teeth **336** could be omitted. The lower portion **334** is formed as a flange extending horizontally and laterally inwardly from the lower end **332b**. The laterally inner end **338** of the flange **334** is connected to the horizontal plate **144** of the rear suspension attachment bracket **142** by a bolt inserted through aligned through holes of the flange **334** and the horizontal plate **144**. The rearwardmost lateral rib **308** of the footrest **364** extending laterally outwardly and rearwardly from the rear end of the mounting flange **210** has a pair of through-holes **340**. The rearwardmost lateral rib **308** is also connected to the horizontal plate **144** by bolts inserted through the aligned through-holes of the rearwardmost lateral rib **308** and the horizontal plate **144**. In the illustrated implementation, the inner end **338** of the flange **334** is also connected to the rearwardmost lateral rib **308**.

Modifications and improvements to the above-described implementations of the present may become apparent to those skilled in the art. The foregoing description is intended to be exemplary rather than limiting. The scope of the present is therefore intended to be limited solely by the scope of the appended claims.

23

What is claimed is:

1. A snowmobile comprising:
 - a frame;
 - a front suspension assembly and a rear suspension assembly connected to the frame;
 - at least one ski operatively connected to the front suspension assembly;
 - an endless drive track operatively connected to the rear suspension assembly;
 - a motor supported by the frame and operatively connected to the drive track for propelling the snowmobile;
 - the frame including:
 - a longitudinally extending tunnel, the rear suspension assembly being connected to the tunnel, the tunnel comprising:
 - a top wall extending generally horizontally and comprising a left edge and a right edge;
 - a planar left bevel wall extending downwardly and leftwardly from the left edge;
 - a left side wall extending downwardly from the left bevel wall;
 - a planar right bevel wall extending downwardly and rightwardly from the right edge; and
 - a right side wall extending downwardly from the right bevel wall; and
 - an upper rear support comprising a left leg and a right leg, each of the left and right legs having a lower end connected to the corresponding one of the left bevel wall and the right bevel wall and extending forwardly, upwardly and laterally inwardly therefrom to an upper end,
 - each of the left and right legs being formed by a side wall being generally planar and having a recess defined in the lower end,
 - the recess of each of the left and right legs having an inner wall being spaced from the side wall and being connected to a corresponding one of the left bevel wall and the right bevel wall of the tunnel, the corresponding one of the left leg and the right leg being thereby connected to the tunnel, a portion of the side wall adjacent the recess in each of the left and right legs being spaced from the tunnel.
2. The snowmobile of claim 1, wherein:
 - the side wall of the left leg extends generally parallel to the left bevel wall; and
 - the side wall of the right leg extends generally parallel to the right bevel wall.
3. The snowmobile of claim 1, wherein each of the left leg and the right leg comprises:
 - a front wall extending laterally inwardly from a front edge of the side wall; and
 - a rear wall extending laterally inwardly from a rear edge of the side wall.
4. The snowmobile of claim 3, wherein, for each of the left and right legs:
 - the front wall extends from the front edge of the side wall at an obtuse angle with respect to the side wall.
5. The snowmobile of claim 3, wherein, for each of the left and right legs:
 - the rear wall extends from the rear edge of the side wall at an obtuse angle with respect to the side wall.
6. The snowmobile of claim 3, wherein each of the left and right legs is a sheet metal structure forming a C-shaped cross-section between the upper and lower ends.

24

7. The snowmobile of claim 3, wherein for each of the left leg and the right leg:
 - a width of the side wall between the front edge and the rear edge thereof tapers towards the upper end.
8. The snowmobile of claim 3, wherein for each of the left leg and the right leg:
 - the front wall extends from the side wall along an entire length of the corresponding one of the left leg and the right leg below the upper end; and
 - the rear wall extends from the side wall along an entire length of the corresponding one of the left leg and the right leg.
9. The snowmobile of claim 8, wherein for each of the left leg and the right leg:
 - the front wall extends laterally inwardly from the front edge of the side wall to an inner edge of the front wall, the inner edge of the front wall being disposed further from the side wall in an upper portion of the corresponding one of the left leg and the right leg than in the lower end thereof; and
 - the rear wall extends laterally inwardly from the rear edge of the side wall to an inner edge of the rear wall, the inner edge of the rear wall being disposed further from the side wall in the upper portion of the corresponding one of the left leg and the right leg than in the lower end thereof.
10. The snowmobile of claim 9, wherein for each of the left leg and the right leg:
 - the inner edge of the front wall below the top wall of the tunnel is disposed between the side wall and the corresponding one of the left and right bevel wall; and
 - the inner edge of the rear wall below the top wall of the tunnel is disposed between the side wall and the corresponding one of the left and right bevel wall.
11. The snowmobile of claim 10, wherein:
 - a left bevel plane contains the left bevel wall;
 - a right bevel plane contains the right bevel wall; and
 - for each of the left leg and the right leg:
 - the inner edge of the front wall is disposed laterally inwardly of the corresponding bevel wall above the top wall of the tunnel; and
 - the inner edge of the rear wall is disposed laterally inwardly of the corresponding bevel wall above the top wall of the tunnel.
12. The snowmobile of claim 1, wherein the motor is an engine, and the snowmobile further comprises:
 - a fuel tank disposed on the tunnel between the left leg and the right leg,
 - the left leg being connected to a left side portion of the fuel tank, and
 - the right leg being connected to a right side portion of the fuel tank.
13. The snowmobile of claim 12, wherein each of the left leg and the right leg comprises:
 - a front wall extending laterally inwardly from a front edge of the side wall; and
 - a rear wall extending laterally inwardly from a rear edge of the side wall,
 wherein:
 - the left side portion of the fuel tank is disposed between the front wall and the rear wall of the left leg; and
 - the right side portion of the fuel tank is disposed between the front wall and the rear wall of the right leg.
14. The snowmobile of claim 13, further comprising:
 - a seat disposed on at least one of the fuel tank and the tunnel; and

25

a fastener connecting the seat and one of the left side portion and the right side portion of the fuel tank to the corresponding one of the left leg and the right leg.

15. The snowmobile of claim 12, further comprising: a seat disposed on at least one of the fuel tank and the tunnel; and

a fastener connecting the seat and one of the left side portion and the right side portion of the fuel tank to the corresponding one of the left leg and the right leg.

16. The snowmobile of claim 15, wherein: the fastener is a left fastener connecting the seat and the left side portion of the fuel tank to the left leg; and the snowmobile further comprises: a right fastener connecting the seat and the right side portion of the fuel tank to the right leg, wherein: the left fastener detachably connects the seat to the left leg, the seat being detachable from the left leg without removing the left fastener from the left leg and the fuel tank, and without disconnecting the fuel tank from the left leg; and the right fastener detachably connects the seat to the right leg, the seat being detachable from the right leg without removing the right fastener from the right leg and the fuel tank, and without disconnecting the fuel tank from the right leg.

17. The snowmobile of claim 1, wherein each of the left and right legs further comprises at least one longitudinally extending recess defined in the side wall and disposed between the upper and lower ends.

18. The snowmobile of claim 1, further comprising: a steering bracket receiving therethrough a steering column operatively connected to the at least one ski; wherein the upper end of each of the left and right legs is connected to the steering bracket.

19. The snowmobile of claim 1, wherein each of the left and right legs is formed as a single integral structure.

20. A snowmobile comprising: a frame; a front suspension assembly and a rear suspension assembly connected to the frame; at least one ski operatively connected to the front suspension assembly; an endless drive track operatively connected to the rear suspension assembly; a motor supported by the frame and operatively connected to the drive track for propelling the snowmobile; the frame including: a longitudinally extending tunnel, the rear suspension assembly being connected to the tunnel, the tunnel comprising: a top wall extending generally horizontally and comprising a left edge and a right edge; a planar left bevel wall extending downwardly and leftwardly from the left edge; a left side wall extending downwardly from the left bevel wall; a planar right bevel wall extending downwardly and rightwardly from the right edge; and

26

a right side wall extending downwardly from the right bevel wall; and an upper rear support comprising a left leg and a right leg, each of the left and right legs having a lower end connected to the corresponding one of the left bevel wall and the right bevel wall and extending forwardly, upwardly and laterally inwardly therefrom to an upper end, each of the left leg and the right leg comprising: a side wall being generally planar; a front wall extending laterally inwardly from a front edge of the side wall; and a rear wall extending laterally inwardly from a rear edge of the side wall, the side wall of the left leg extending generally parallel and adjacent to the left bevel wall, and the side wall of the right leg extending generally parallel and adjacent to the right bevel wall.

21. The snowmobile of claim 20, wherein, for each of the left leg and the right leg: the front wall extends from the front edge of the side wall at an obtuse angle with respect to the side wall; and the rear wall extends from the rear edge of the side wall at an obtuse angle with respect to the side wall.

22. The snowmobile of claim 20, wherein: a left bevel plane contains the left bevel wall; a right bevel plane contains the right bevel wall; and for each of the left leg and the right leg: the front wall extends laterally inwardly from the front edge of the side wall to an inner edge of the front wall, the inner edge of the front wall being disposed laterally inwardly of the corresponding bevel wall above the top wall of the tunnel; and the rear wall extends laterally inwardly from the rear edge of the side wall to an inner edge of the rear wall, the inner edge of the rear wall being disposed laterally inwardly of the corresponding bevel wall above the top wall of the tunnel.

23. The snowmobile of claim 20, wherein the motor is an engine, and the snowmobile further comprises: a fuel tank disposed on the tunnel between the left leg and the right leg, the left leg being connected to a left side portion of the fuel tank, and the right leg being connected to a right side portion of the fuel tank.

24. The snowmobile of claim 23, wherein: the left side portion of the fuel tank is disposed between the front wall and the rear wall of the left leg; and the right side portion of the fuel tank is disposed between the front wall and the rear wall of the right leg.

25. The snowmobile of claim 20, further comprising: a steering bracket receiving therethrough a steering column operatively connected to the at least one ski; wherein the upper end of each of the left and right legs is connected to the steering bracket.

* * * * *