

FIG. 1

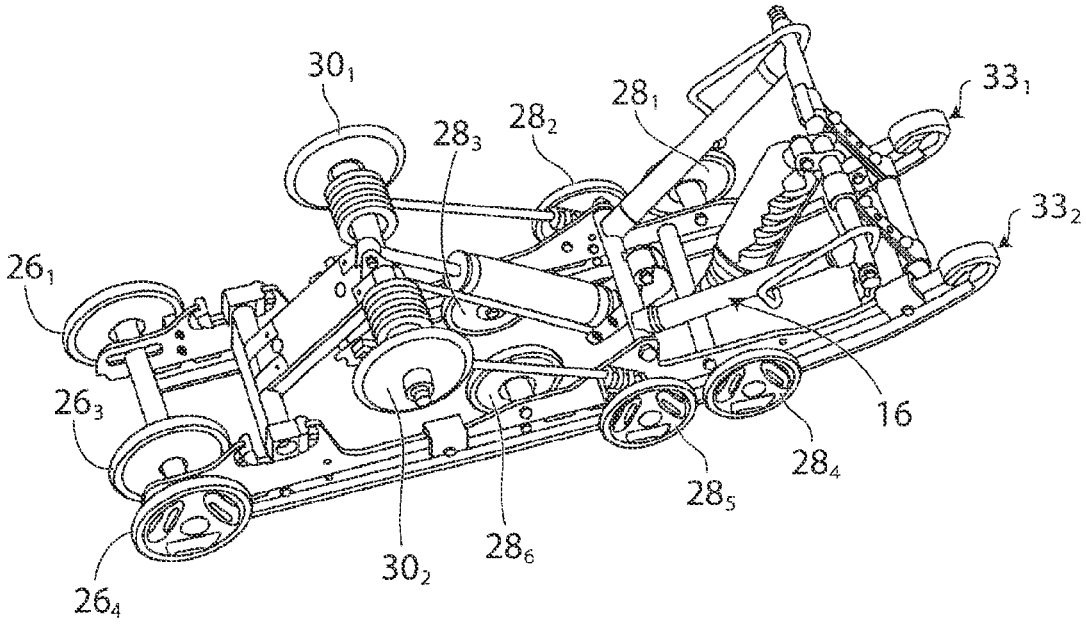

FIG. 2

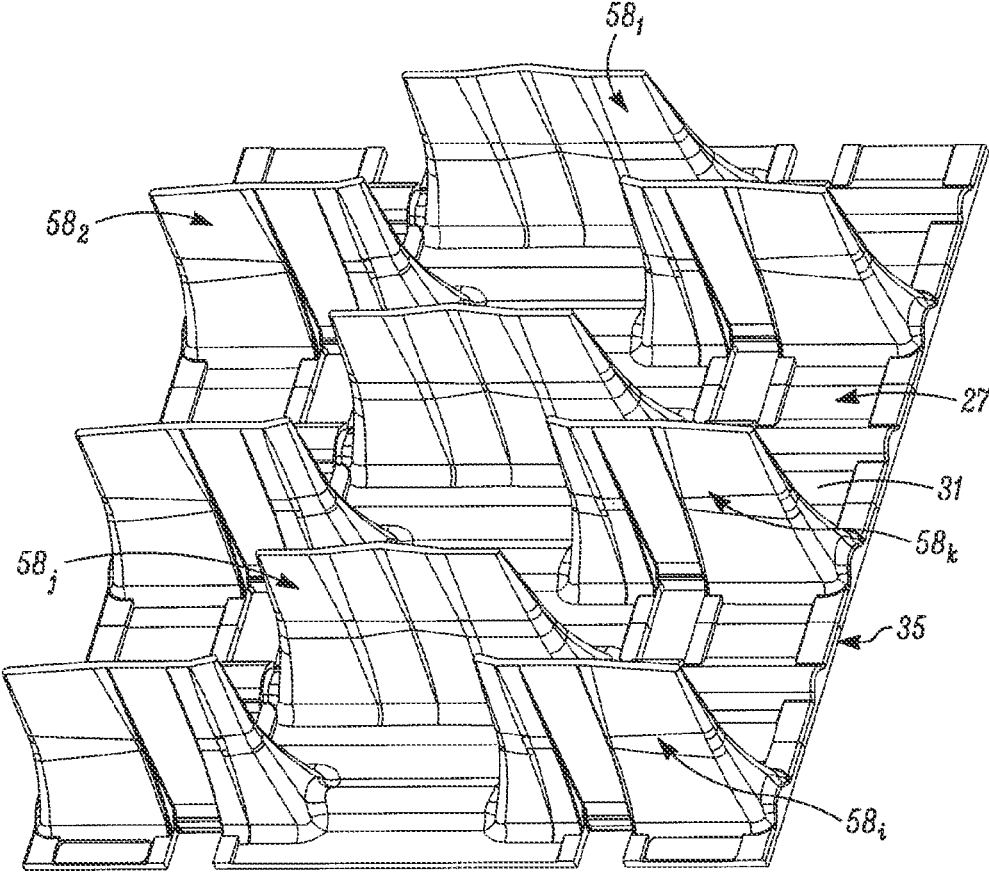

FIG. 3

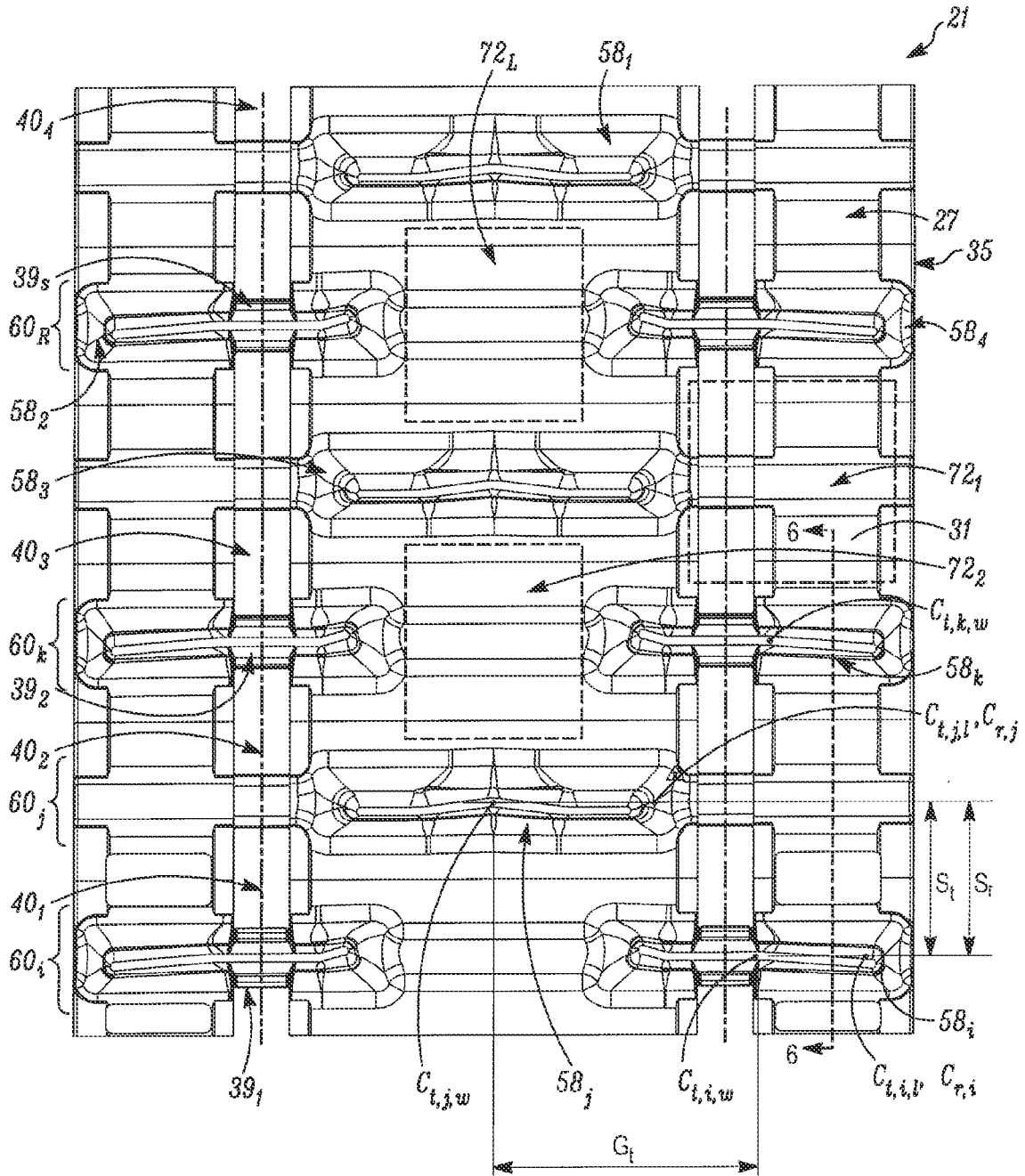

FIG. 4

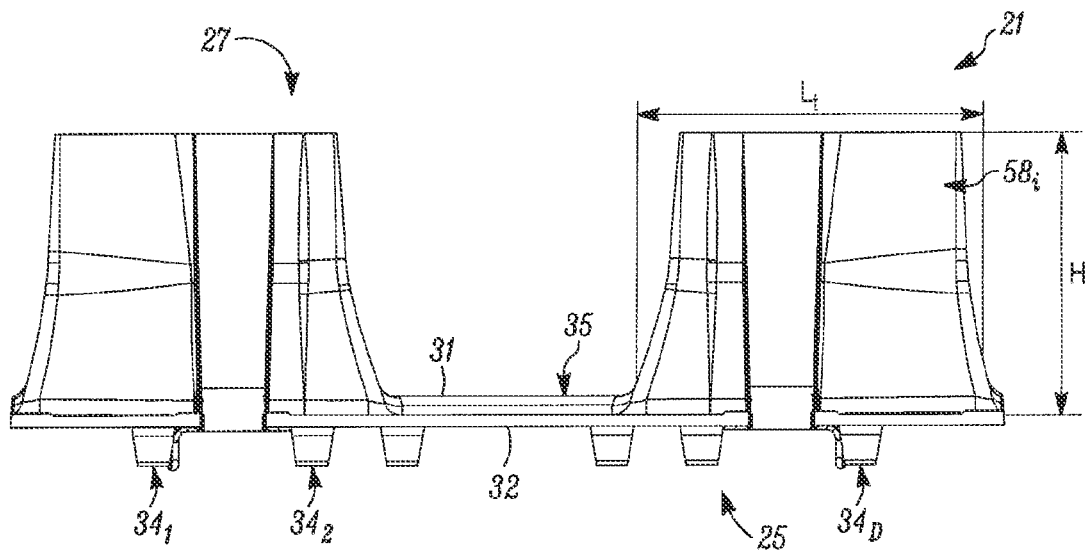

FIG. 5

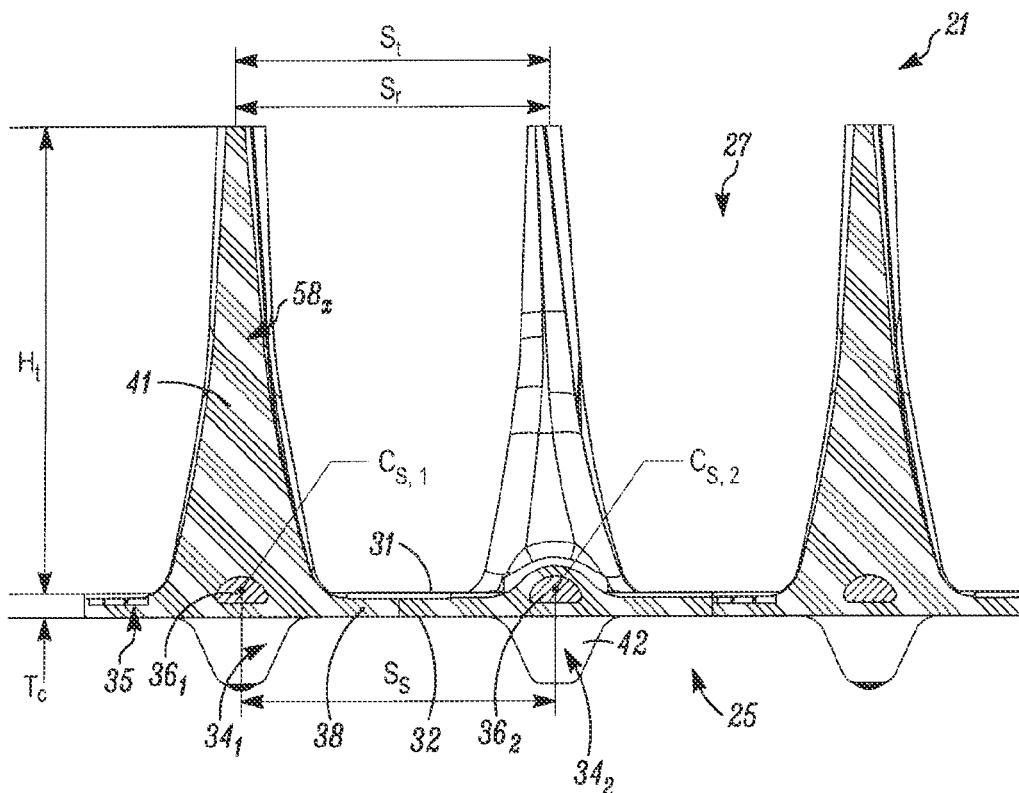

FIG. 6

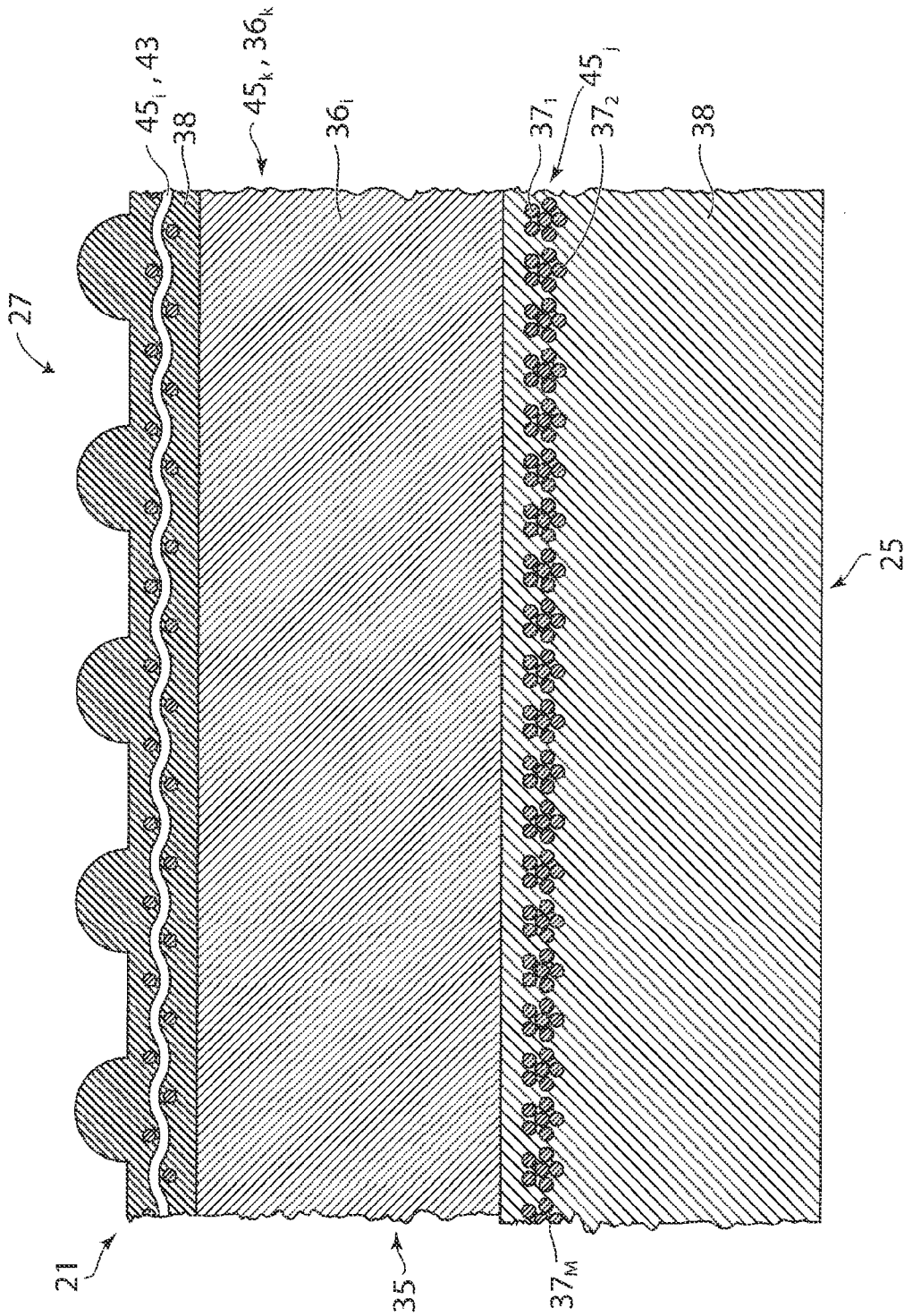

FIG. 7

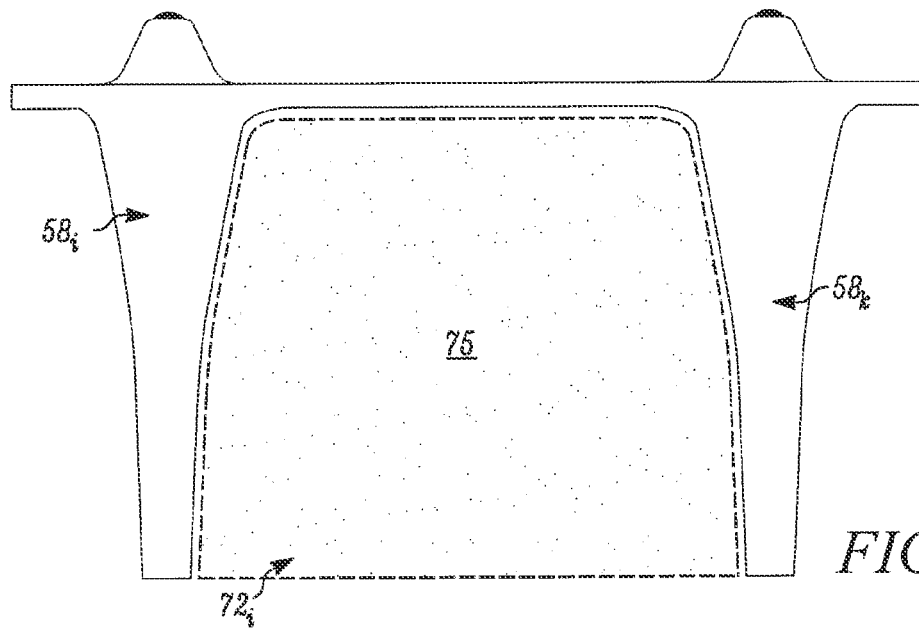

FIG. 8

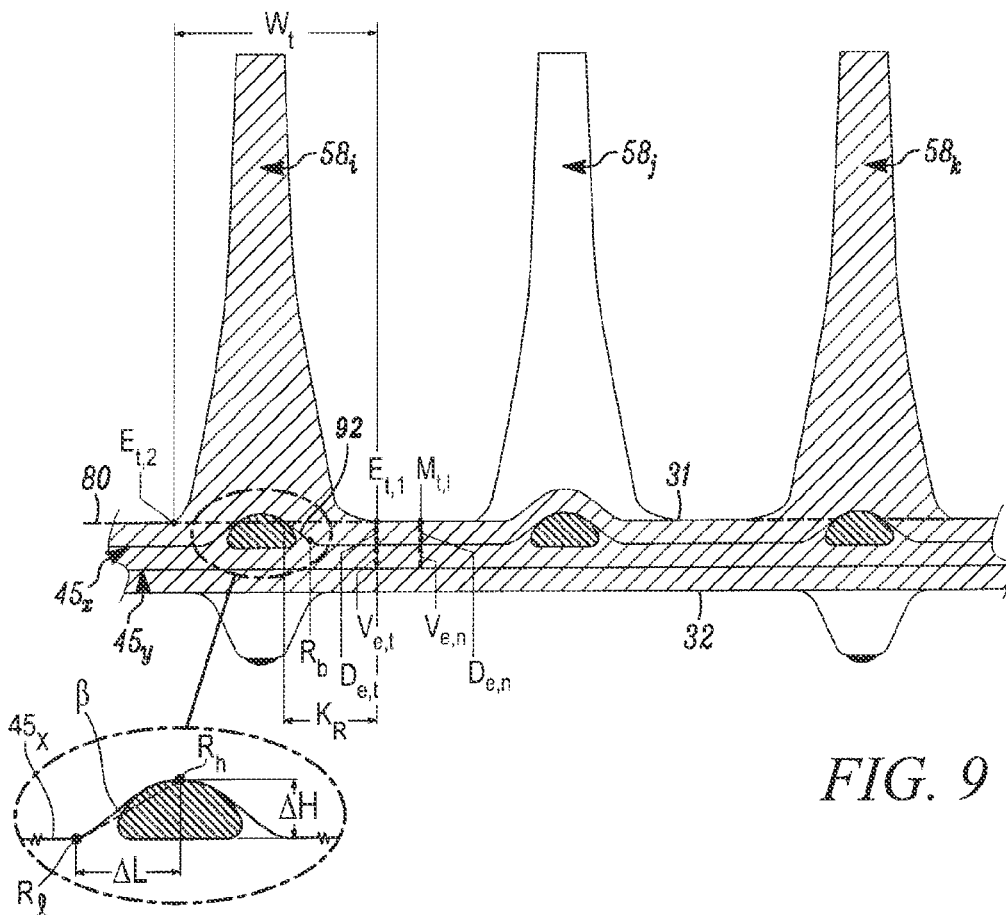

FIG. 9

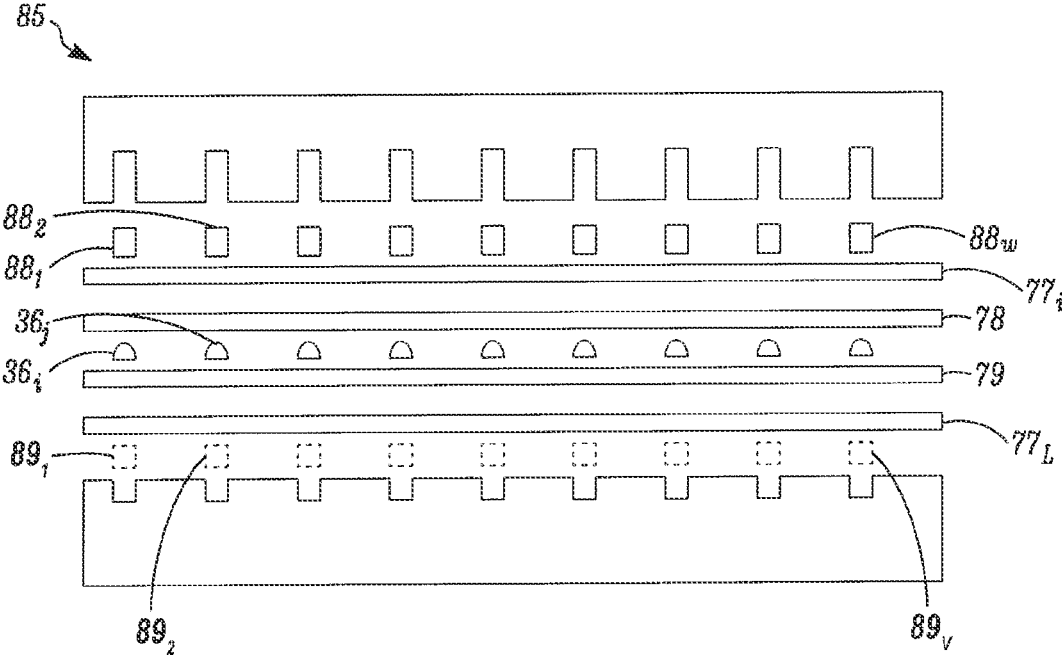

FIG. 10

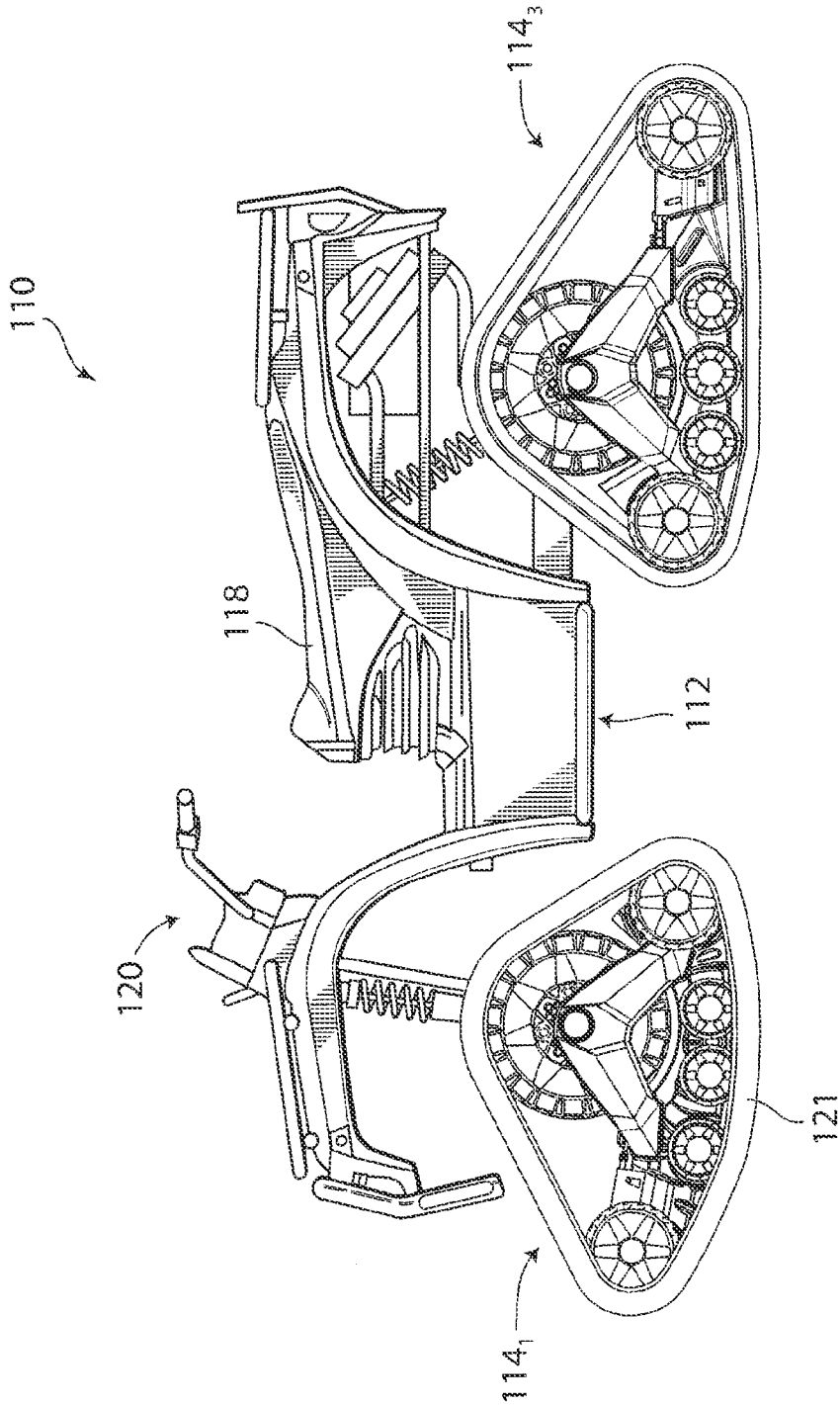

FIG. 11

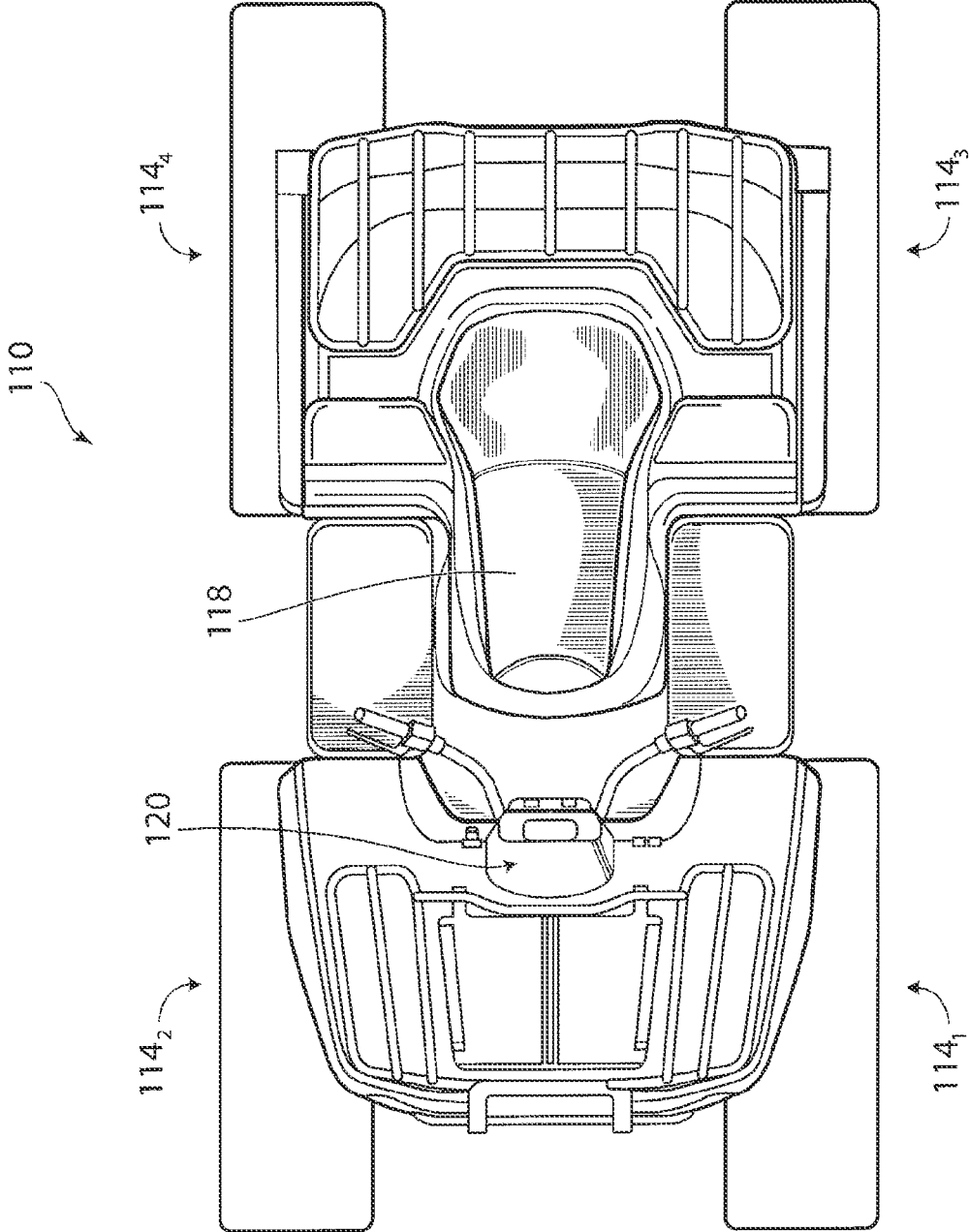

FIG. 12

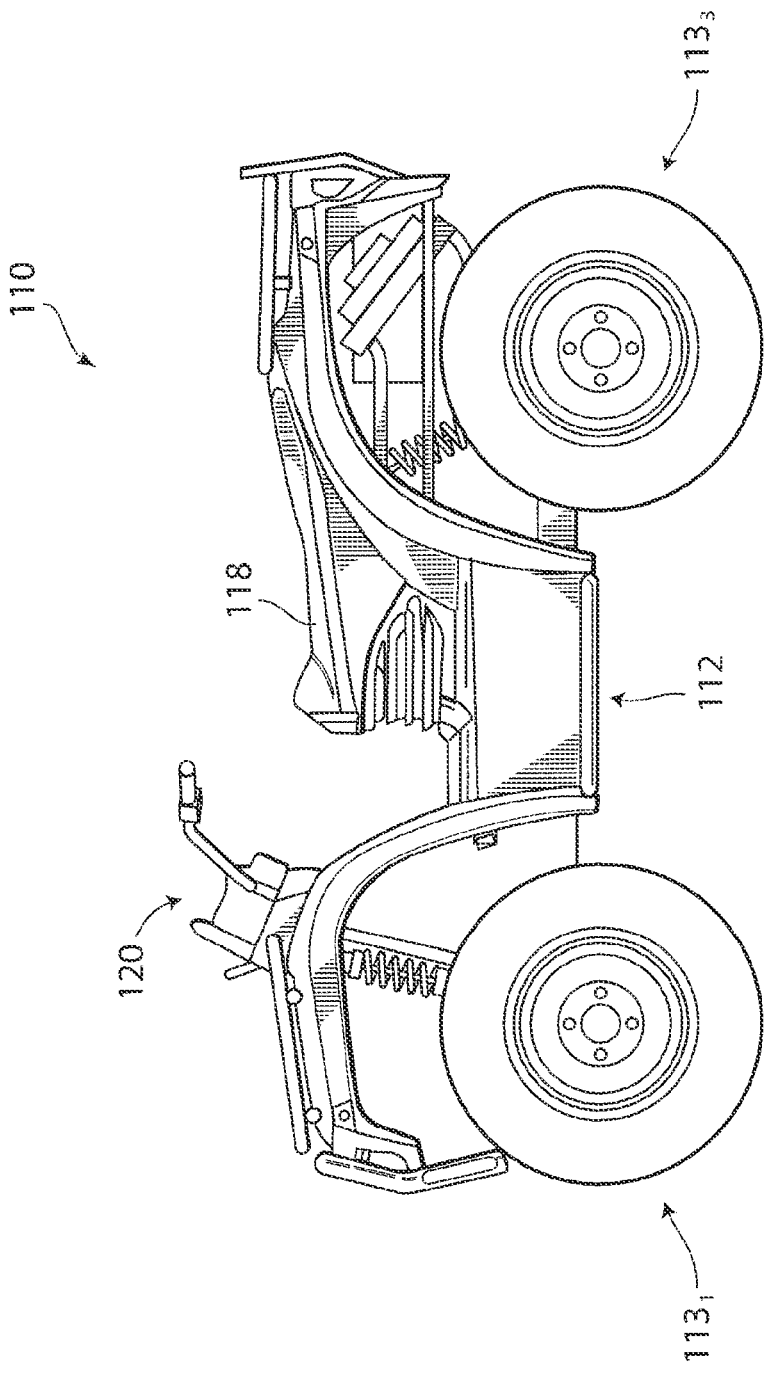

FIG. 13

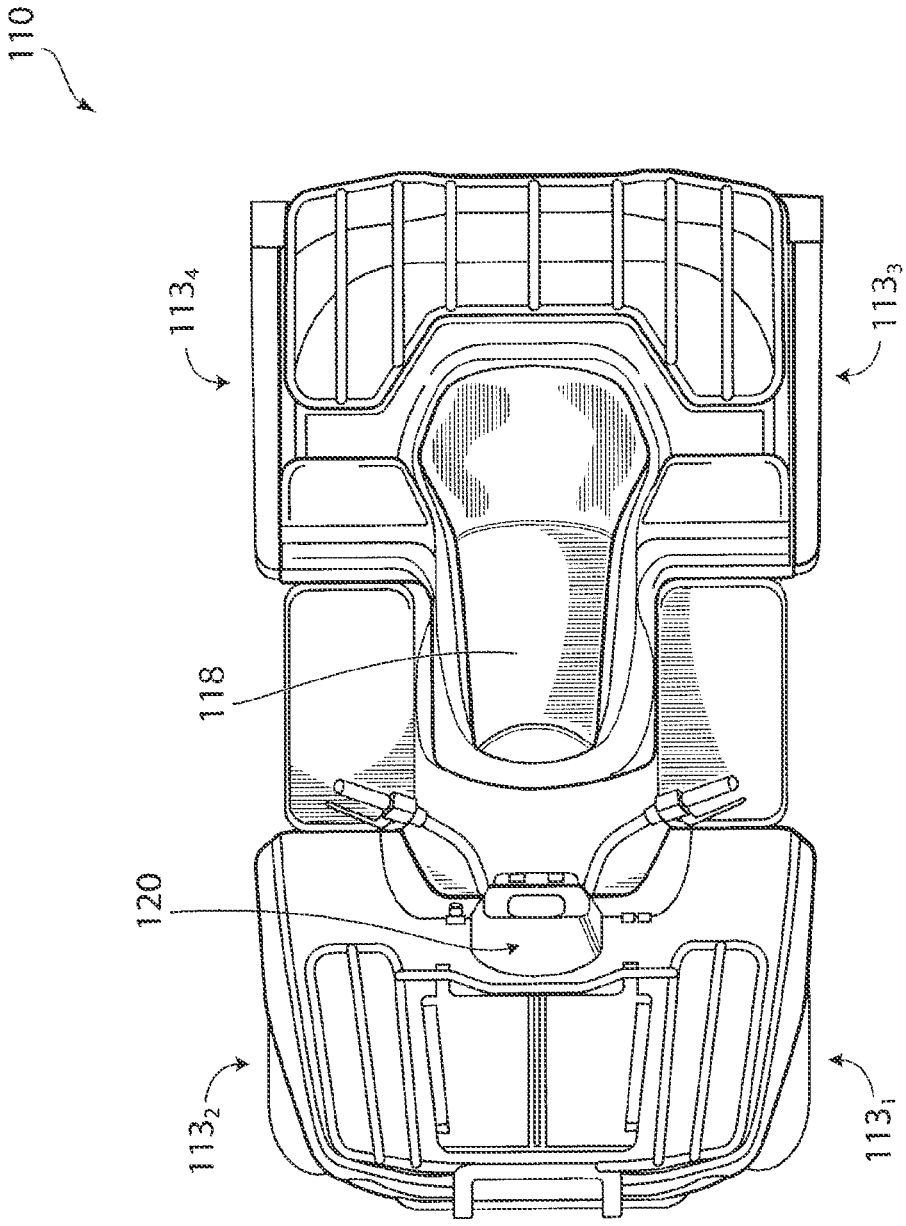

FIG. 14

**TRACK FOR TRACTION OF AN OFF-ROAD  
VEHICLE SUCH AS A SNOWMOBILE OR AN  
ALL-TERRAIN VEHICLE (ATV)**

FIELD

[0001] The invention relates generally to off-road vehicles such as snowmobiles and all-terrain vehicles (ATV) and, more particularly, to tracks for traction of snowmobiles, ATVs and other off-road vehicles.

BACKGROUND

[0002] Snowmobiles allow efficient travel on snowy and in some cases icy grounds. A snowmobile comprises a track system which engages the ground to provide traction. The track system comprises a track-engaging assembly and a track that moves around the track-engaging assembly and engages the ground to generate traction. The track typically comprises an elastomeric body in which are embedded certain reinforcements, such as transversal stiffening rods providing transversal rigidity to the track, longitudinal cables providing tensional strength, and/or fabric layers. The track-engaging assembly comprises wheels and in some cases slide rails around which the track is driven.

[0003] Various considerations are important when it comes to use and performance of a snowmobile's track.

[0004] For example, traction generated by the track is a significant factor. The track typically comprises traction projections (sometimes referred to as "traction profiles" or "traction lugs") on its ground-engaging outer side to enhance traction. While they are useful, the traction projections may be limited in size and/or number to manage the track's weight and/or for other reasons.

[0005] As another example, a shape of the track's body may affect performance. For instance, the track's body is thin to facilitate its motion around the snowmobile's track-engaging assembly (e.g., to reduce power consumption). However, the thinness of the track's body may be limited because of the track's manufacturing process and the reinforcements embedded in the track's body.

[0006] Similar considerations may arise for all-terrain vehicles (ATVs) equipped with track systems having tracks providing traction to the ATVs on the ground (e.g., an ATV equipped with two front track systems in place of two front wheels and two rear track systems in place of two rear wheels) and/or for other types of off-road vehicles.

[0007] While certain developments have been made to improve performance of tracks for snowmobiles, ATVs and other off-road vehicles, there remains a need for improvements in such tracks.

SUMMARY

[0008] In accordance with an aspect of the invention, there is provided a track for traction of an off-road vehicle. The track is mountable around a track-engaging assembly of the off-road vehicle. The track-engaging assembly comprises a drive wheel for driving the track. The track is elastomeric to be flexible around the track-engaging assembly. The track comprises: an inner surface for facing the track-engaging assembly; a ground-engaging outer surface for engaging the ground; and a plurality of traction projections projecting from the ground-engaging outer surface. A first one of the traction projections and a second one of the traction projections are spaced apart in a longitudinal direction of the track

and offset from one another in a widthwise direction of the track. The second one of the traction projections succeeds the first one of the traction projections in the longitudinal direction of the track. A height of the first one of the traction projections is at least as great as a longitudinal spacing of the first one of the traction projections and the second one of the traction projections.

[0009] In accordance with another aspect of the invention, there is provided a track for traction of an off-road vehicle. The track is mountable around a track-engaging assembly of the off-road vehicle. The track-engaging assembly comprises a drive wheel for driving the track. The track is elastomeric to be flexible around the track-engaging assembly. The track comprises: an inner surface for facing the track-engaging assembly; a ground-engaging outer surface for engaging the ground; and a plurality of traction projections projecting from the ground-engaging outer surface. The traction projections are arranged in a plurality of traction projection rows that are spaced apart in a longitudinal direction of the track. A first one of the traction projections and a second one of the traction projections are spaced apart in the longitudinal direction of the track and generally aligned with one another in a widthwise direction of the track. A height of the first one of the traction projections is at least as great as a ratio of (i) a longitudinal spacing of the first one of the traction projections and the second one of the traction projections over (ii) a number of traction projection row transitions from the first one of the traction projections to the second one of the traction projections.

[0010] In accordance with another aspect of the invention, there is provided a track for traction of an off-road vehicle. The track is mountable around a track-engaging assembly of the off-road vehicle. The track-engaging assembly comprises a drive wheel for driving the track. The track is elastomeric to be flexible around the track-engaging assembly. The track comprises: an inner surface for facing the track-engaging assembly; a ground-engaging outer surface for engaging the ground; and a plurality of traction projections projecting from the ground-engaging outer surface. A first one of the traction projections and a second one of the traction projections are spaced apart in a longitudinal direction of the track. The second one of the traction projections succeeds the first one of the traction projections in the longitudinal direction of the track. A height of the first one of the traction projections is at least as great as a longitudinal spacing of the first one of the traction projections and the second one of the traction projections.

[0011] In accordance with another aspect of the invention, there is provided a track for traction of an off-road vehicle. The track is mountable around a track-engaging assembly of the off-road vehicle. The track-engaging assembly comprises a drive wheel for driving the track. The track is elastomeric to be flexible around the track-engaging assembly. The track comprises: an inner surface for facing the track-engaging assembly; a ground-engaging outer surface for engaging the ground; and a plurality of traction projections projecting from the ground-engaging outer surface. A height of each traction projection of the traction projections is greater than a thickness of the track from the inner surface to the ground-engaging outer surface. The thickness of the track is no more than 0.20 inches.

[0012] In accordance with another aspect of the invention, there is provided a track for traction of an off-road vehicle.

The track is mountable around a track-engaging assembly of the off-road vehicle. The track-engaging assembly comprises a drive wheel for driving the track. The track is elastomeric to be flexible around the track-engaging assembly. The track comprises: an inner surface for facing the track-engaging assembly; a ground-engaging outer surface for engaging the ground; a plurality of traction projections projecting from the ground-engaging outer surface; and a reinforcement embedded between the inner surface and the ground-engaging outer surface. At least part of the reinforcement is located below a level of the ground-engaging outer surface underneath each traction projection of the traction projections.

**[0013]** In accordance with another aspect of the invention, there is provided a track for traction of an off-road vehicle. The track is mountable around a track-engaging assembly of the off-road vehicle. The track-engaging assembly comprises a drive wheel for driving the track. The track is elastomeric to be flexible around the track-engaging assembly. The track comprises: an inner surface for facing the track-engaging assembly; a ground-engaging outer surface for engaging the ground; a plurality of traction projections projecting from the ground-engaging outer surface; and a reinforcement embedded between the inner surface and the ground-engaging outer surface. A gradient of the reinforcement underneath each traction projection of the traction projections is at least 0.6.

**[0014]** In accordance with another aspect of the invention, there is provided a track for traction of an off-road vehicle. The track is mountable around a track-engaging assembly of the off-road vehicle. The track-engaging assembly comprises a drive wheel for driving the track. The track is elastomeric to be flexible around the track-engaging assembly. The track comprises: an inner surface for facing the track-engaging assembly; a ground-engaging outer surface for engaging the ground; a plurality of traction projections projecting from the ground-engaging outer surface; and a reinforcement embedded between the inner surface and the ground-engaging outer surface. For each traction projection of the traction projections, a ratio of (i) a distance from the reinforcement to a level of the ground-engaging outer surface at an extremity of the traction projection in a longitudinal direction of the track over (ii) a distance from the reinforcement to level of the ground-engaging outer surface at a longitudinal midpoint between the traction projection and an adjacent one of the traction projections that succeeds the traction projection in the longitudinal direction of the track is between 0.9 and 1.1.

**[0015]** In accordance with another aspect of the invention, there is provided a track for traction of an off-road vehicle. The track is mountable around a track-engaging assembly of the off-road vehicle. The track-engaging assembly comprises a drive wheel for driving the track. The track is elastomeric to be flexible around the track-engaging assembly. The track comprises: an inner surface for facing the track-engaging assembly; a ground-engaging outer surface for engaging the ground; a plurality of traction projections projecting from the ground-engaging outer surface; a first reinforcement embedded between the inner surface and the ground-engaging outer surface; and a second reinforcement embedded between the inner surface and the ground-engaging outer surface and spaced from the first reinforcement in a thickness direction of the track. For each traction projection of the traction projections, a ratio of (i) a distance

between the first reinforcement and the second reinforcement in the thickness direction of the track at an extremity of the traction projection in a longitudinal direction of the track over (ii) a distance between the first reinforcement and the second reinforcement in the thickness direction of the track at a longitudinal midpoint between the traction projection and an adjacent one of the traction projections that succeeds the traction projection in the longitudinal direction of the track is between 0.9 and 1.1.

**[0016]** In accordance with another aspect of the invention, there is provided a method of manufacturing a track for traction of an off-road vehicle. The track is mountable around a track-engaging assembly of the off-road vehicle. The track-engaging assembly comprises a drive wheel for driving the track. The track is elastomeric to be flexible around the track-engaging assembly. The method comprises: providing a plurality of layers of elastomeric material in a mold; and providing a plurality of distinct pieces of elastomeric material in the mold. The distinct pieces of elastomeric material are spaced apart from one another in a longitudinal direction of the track. The method comprises molding the track in the mold such that: (i) the layers of elastomeric material form at least part of an inner surface of the track and a ground-engaging outer surface of the track; and (ii) the distinct pieces of elastomeric material form at least part of respective ones of a plurality of traction projections projecting from the ground-engaging outer surface of the track.

**[0017]** These and other aspects of the invention will now become apparent to those of ordinary skill in the art upon review of the following description of embodiments of the invention in conjunction with the accompanying drawings.

#### BRIEF DESCRIPTION OF THE DRAWINGS

**[0018]** A detailed description of embodiments of the invention is provided below, by way of example only, with reference to the accompanying drawings, in which:

**[0019]** FIG. 1 shows an example of a snowmobile comprising a track system in accordance with an embodiment of the invention;

**[0020]** FIG. 2 shows a perspective view of components of the track system;

**[0021]** FIGS. 3 to 6 respectively show a perspective view, a plan view, an elevation view, and a longitudinal cross-sectional view of part of a track of the track system;

**[0022]** FIG. 7 shows a widthwise cross-sectional view of part of the track;

**[0023]** FIG. 8 shows an example of snow and/or other ground matter in a space between traction projections of the track;

**[0024]** FIG. 9 shows an example of positions of reinforcements embedded in elastomeric material of the track;

**[0025]** FIG. 10 shows an example of a process to manufacture the track; and

**[0026]** FIGS. 11 to 14 show an example of an all-terrain vehicle (ATV) comprising track systems in accordance with another embodiment of the invention, instead of being equipped with ground-engaging wheels.

**[0027]** It is to be expressly understood that the description and drawings are only for the purpose of illustrating certain embodiments of the invention and are an aid for understanding. They are not intended to be a definition of the limits of the invention.

## DETAILED DESCRIPTION OF EMBODIMENTS

**[0028]** FIG. 1 shows an example of a snowmobile 10 in accordance with an embodiment of the invention. The snowmobile 10 is designed for travelling on snow and in some cases ice. In this embodiment, the snowmobile 10 comprises a frame 11, a powertrain 12, a track system 14, a ski assembly 17, a seat 18, and a user interface 20, which enables a user to control the snowmobile 10.

**[0029]** The powertrain 12 is configured for generating motive power and transmitting motive power to the track system 14 to propel the snowmobile 10 on the ground. To that end, the powertrain 12 comprises a prime mover 15, which is a source of motive power that comprises one or more motors (e.g., an internal combustion engine, an electric motor, etc.). For example, in this embodiment, the prime mover 15 comprises an internal combustion engine. In other embodiments, the prime mover 15 may comprise another type of motor (e.g., an electric motor) or a combination of different types of motor (e.g., an internal combustion engine and an electric motor). The prime mover 15 is in a driving relationship with the track system 14. That is, the powertrain 12 transmits motive power from the prime mover 15 to the track system 14 in order to drive (i.e., impart motion to) the track system 14.

**[0030]** The ski assembly 17 is turnable to allow steering of the snowmobile 10. In this embodiment, the ski assembly 17 comprises a pair of skis 19<sub>1</sub>, 19<sub>2</sub> connected to the frame 11 via a front suspension unit.

**[0031]** The seat 18 accommodates the user of the snowmobile 10. In this case, the seat 18 is a straddle seat and the snowmobile 10 is usable by a single person such that the seat 18 accommodates only that person driving the snowmobile 10. In other cases, the seat 18 may be another type of seat, and/or the snowmobile 10 may be usable by two individuals, namely one person driving the snowmobile 10 and a passenger, such that the seat 18 may accommodate both of these individuals (e.g., behind one another) or the snowmobile 10 may comprise an additional seat for the passenger.

**[0032]** The user interface 20 allows the user to interact with the snowmobile 10 to control the snowmobile 10. More particularly, the user interface 20 comprises an accelerator, a brake control, and a steering device that are operated by the user to control motion of the snowmobile 10 on the ground. In this case, the steering device comprises handlebars, although it may comprise a steering wheel or other type of steering element in other cases. The user interface 20 also comprises an instrument panel (e.g., a dashboard) which provides indicators (e.g., a speedometer indicator, a tachometer indicator, etc.) to convey information to the user.

**[0033]** The track system 14 engages the ground to generate traction of the snowmobile 10. In this embodiment, the track system 14 comprises a track-engaging assembly 24 and a track 21 disposed around the track-engaging assembly 24. More particularly, in this embodiment, with additional reference to FIG. 2, the track-engaging assembly 24 comprises a plurality of wheels, including a plurality of drive wheels 22<sub>1</sub>, 22<sub>2</sub> and a plurality of idler wheels, which includes rear idler wheels 28<sub>1</sub>-26<sub>4</sub>, lower roller wheels 28<sub>1</sub>-28<sub>6</sub>, and upper roller wheels 30<sub>1</sub>, 30<sub>2</sub>. The track-engaging assembly 24 also comprises a plurality of slide rails 33<sub>1</sub>, 33<sub>2</sub>. Various components of the track-engaging assembly 24, including the idler wheels 26<sub>1</sub>-26<sub>4</sub>, 28<sub>1</sub>-28<sub>6</sub>, 30<sub>1</sub>, 30<sub>2</sub> and the slide rails 33<sub>1</sub>, 33<sub>2</sub> are supported by a suspension unit 16. The track system 14 has a longitudinal direction and a first

longitudinal end and a second longitudinal end that define a length of the track system 14. The track system 14 has a widthwise direction and a width that is defined by a width of the track 21. The track system 14 has a height direction that is normal to its longitudinal direction and its widthwise direction.

**[0034]** The track 21 engages the ground to provide traction to the snowmobile 10. As further discussed below, in this embodiment, the track 21 may be designed and constructed to enhance traction and/or provide other benefits.

**[0035]** A length of the track 21 allows the track 21 to be mounted around the track-engaging assembly 24. In view of its closed configuration without ends that allows it to be disposed and moved around the track-engaging assembly 24, the track 21 can be referred to as an “endless” track. With additional reference to FIGS. 3 to 6, the track 21 comprises an inner side 25 and a ground-engaging outer side 27. The inner side 25 faces the wheels 22<sub>1</sub>, 22<sub>2</sub>, 26<sub>1</sub>-26<sub>4</sub>, 28<sub>1</sub>-28<sub>6</sub>, 30<sub>1</sub>, 30<sub>2</sub> and the slide rails 33<sub>1</sub>, 33<sub>2</sub>. The ground-engaging outer side 27 engages the ground. A top run 65 of the track 21 extends between the longitudinal ends of the track system 14 and over the wheels 22<sub>1</sub>, 22<sub>2</sub>, 26<sub>1</sub>-26<sub>4</sub>, 28<sub>1</sub>-28<sub>6</sub>, 30<sub>1</sub>, 30<sub>2</sub>, and a bottom run 66 of the track 21 extends between the longitudinal ends of the track system 14 and under the wheels 22<sub>1</sub>, 22<sub>2</sub>, 26<sub>1</sub>-26<sub>4</sub>, 28<sub>1</sub>-28<sub>6</sub>, 30<sub>1</sub>, 30<sub>2</sub> and the slide rails 33<sub>1</sub>, 33<sub>2</sub>. The track 21 has a longitudinal axis which defines a longitudinal direction of the track 21 (i.e., a direction generally parallel to its longitudinal axis) and transversal directions of the track (i.e., directions transverse to its longitudinal axis), including a widthwise direction of the track (i.e., a lateral direction generally perpendicular to its longitudinal axis). The track 21 has a thickness direction normal to its longitudinal and widthwise directions.

**[0036]** The track 21 is elastomeric, i.e., comprises elastomeric material, to be flexible around the track-engaging assembly 24. The elastomeric material of the track 21 can include any polymeric material with suitable elasticity. In this embodiment, the elastomeric material of the track 21 includes rubber. Various rubber compounds may be used and, in some cases, different rubber compounds may be present in different areas of the track 21. In other embodiments, the elastomeric material of the track 21 may include another elastomer in addition to or instead of rubber (e.g., polyurethane elastomer).

**[0037]** More particularly, the track 21 comprises an endless body 35 underlying its inner side 25 and ground-engaging outer side 27. In view of its underlying nature, the body 35 will be referred to as a “carcass”. The carcass 35 is elastomeric in that it comprises elastomeric material 38 which allows the carcass 35 to elastically change in shape and thus the track 21 to flex as it is in motion around the track-engaging assembly 24. The elastomeric material 38 can be any polymeric material with suitable elasticity. In this embodiment, the elastomeric material 38 includes rubber. Various rubber compounds may be used and, in some cases, different rubber compounds may be present in different areas of the carcass 35. In other embodiments, the elastomeric material 38 may include another elastomer in addition to or instead of rubber (e.g., polyurethane elastomer).

**[0038]** In this embodiment, with additional reference to FIG. 7 the carcass 35 comprises a plurality of reinforcements 45<sub>1</sub>-45<sub>p</sub> embedded in its rubber 38. These reinforcements 45<sub>1</sub>-45<sub>p</sub> can take on various forms.

[0039] For example, in this embodiment, a subset of the reinforcements  $45_i$ - $45_p$  is a plurality of transversal stiffening rods  $36_1$ - $36_N$  that extend transversally to the longitudinal direction of the track **21** to provide transversal rigidity to the track **21**. More particularly, in this embodiment, the transversal stiffening rods  $36_1$ - $36_N$  extend in the widthwise direction of the track **21**. Each of the transversal stiffening rods  $36_1$ - $36_N$  may have various shapes and be made of any suitably rigid material (e.g., metal, polymer or composite material).

[0040] As another example, in this embodiment, the reinforcement  $45_i$  is a layer of reinforcing cables  $37_1$ - $37_M$  that are adjacent to one another and extend generally in the longitudinal direction of the track **21** to enhance strength in tension of the track **21** along its longitudinal direction. In this case, each of the reinforcing cables  $37_1$ - $37_M$  is a cord including a plurality of strands (e.g., textile fibers or metallic wires). In other cases, each of the reinforcing cables  $37_1$ - $37_M$  may be another type of cable and may be made of any material suitably flexible longitudinally (e.g., fibers or wires of metal, plastic or composite material). In some examples of implementation, respective ones of the reinforcing cables  $37_1$ - $37_M$  may be constituted by a single continuous cable length wound helically around the track **21**. In other examples of implementation, respective ones of the transversal cables  $37_1$ - $37_M$  may be separate and independent from one another (i.e., unconnected other than by rubber of the track **21**).

[0041] As yet another example, in this embodiment, the reinforcement  $45_j$  is a layer of reinforcing fabric **43**. The reinforcing fabric **43** comprises thin pliable material made usually by weaving, felting, knitting, interlacing, or otherwise crossing natural or synthetic elongated fabric elements, such as fibers, filaments, strands and/or others, such that some elongated fabric elements extend transversally to the longitudinal direction of the track **21** to have a reinforcing effect in a transversal direction of the track **21**. For instance, the reinforcing fabric **43** may comprise a ply of reinforcing woven fibers (e.g., nylon fibers or other synthetic fibers). For example, the reinforcing fabric **43** may protect the transversal stiffening rods  $36_1$ - $36_N$ , improve cohesion of the track **21**, and counter its elongation.

[0042] The carcass **35** may be molded into shape in a molding process during which the rubber **38** is cured. For example, in this embodiment, a mold may be used to consolidate layers of rubber providing the rubber **38** of the carcass **35**, the reinforcing cables  $37_1$ - $37_M$  and the layer of reinforcing fabric **43**.

[0043] In this embodiment, the track **21** is a one-piece “jointless” track such that the carcass **35** is a one-piece jointless carcass. In other embodiments, the track **21** may be a “jointed” track (i.e., having at least one joint connecting adjacent parts of the track **21**) such that the carcass **35** is a jointed carcass (i.e., which has adjacent parts connected by the at least one joint). For example, in some embodiments, the track **21** may comprise a plurality of track sections interconnected to one another at a plurality of joints, in which case each of these track sections includes a respective part of the carcass **35**. In other embodiments, the track **21** may be a one-piece track that can be closed like a belt with connectors at both of its longitudinal ends to form a joint.

[0044] The ground-engaging outer side **27** of the track **21** comprises a ground-engaging outer surface **31** of the carcass **35** and a plurality of traction projections  $58_1$ - $58_T$  that project

outwardly from the ground-engaging outer surface **31** to enhance traction on the ground. The traction projections  $58_1$ - $58_T$ , which can be referred to as “traction lugs” or “traction profiles”, may have any suitable shape (e.g., straight shapes, curved shapes, shapes with straight parts and curved parts, etc.).

[0045] In this embodiment, each of the traction projection  $58_1$ - $58_T$  is an elastomeric traction projection in that it comprises elastomeric material **41**. The elastomeric material **41** can be any polymeric material with suitable elasticity. More particularly, in this embodiment, the elastomeric material **41** includes rubber. Various rubber compounds may be used and, in some cases, different rubber compounds may be present in different areas of each of the traction projections  $58_1$ - $58_T$ . In other embodiments, the elastomeric material **41** may include another elastomer in addition to or instead of rubber (e.g., polyurethane elastomer).

[0046] The traction projections  $58_1$ - $58_T$  may be provided on the ground-engaging outer side **27** in various ways. For example, in this embodiment, the traction projections  $58_1$ - $58_T$  are provided on the ground-engaging outer side **27** by being molded with the carcass **35**.

[0047] The inner side **25** of the track **21** comprises an inner surface **32** of the carcass **35** and a plurality of inner projections  $34_1$ - $34_D$  that project inwardly from the inner surface **32** and are positioned to contact at least some of the wheels  $22_1$ ,  $22_2$ ,  $26_1$ - $26_4$ ,  $28_1$ - $28_6$ ,  $30_1$ ,  $30_2$  and/or some of the slide rails  $33_1$ ,  $33_2$  to do at least one of driving (i.e., imparting motion to) the track **21** and guiding the track **21**. Since each of them is used to do at least one of driving the track **21** and guiding the track **21**, the inner projections  $34_1$ - $34_D$  can be referred to as “drive/guide projections” or “drive/guide lugs”. In some cases, a drive/guide lug  $34_i$  may interact with a given one of the drive wheels  $22_1$ ,  $22_2$  to drive the track **21**, in which case the drive/guide lug  $34_i$  is a drive lug. In other cases, a drive/guide lug  $34_i$  may interact with a given one of the idler wheels  $26_1$ - $26_4$ ,  $28_1$ - $28_6$ ,  $30_1$ ,  $30_2$  and/or a given one of the slide rails  $33_1$ ,  $33_2$  to guide the track **21** to maintain proper track alignment and prevent de-tracking without being used to drive the track **21**, in which case the drive/guide lug  $34_i$  is a guide lug. In yet other cases, a drive/guide lug  $34_i$  may both (i) interact with a given one of the drive wheels  $22_1$ ,  $22_3$  to drive the track **21** and (ii) interact with a given one of the idler wheels  $26_1$ - $26_4$ ,  $28_1$ - $28_6$ ,  $30_1$ ,  $30_2$  and/or a given one of the slide rails  $33_1$ ,  $33_2$  to guide the track **21**, in which case the drive/guide lug  $34_i$  is both a drive lug and a guide lug.

[0048] In this embodiment, each of the drive/guide lugs  $34_1$ - $34_D$  is an elastomeric drive/guide lug in that it comprises elastomeric material **42**. The elastomeric material **42** can be any polymeric material with suitable elasticity. More particularly, in this embodiment, the elastomeric material **42** includes rubber. Various rubber compounds may be used and, in some cases, different rubber compounds may be present in different areas of each of the drive/guide lugs  $34_1$ - $34_D$ . In other embodiments, the elastomeric material **42** may include another elastomer in addition to or instead of rubber (e.g., polyurethane elastomer).

[0049] The drive/guide lugs  $34_1$ - $34_D$  may be provided on the inner side **25** in various ways. For example, in this embodiment, the drive/guide lugs  $34_1$ - $34_D$  are provided on the inner side **25** by being molded with the carcass **35**.

[0050] The carcass **35** has a thickness  $T_c$  which is relatively small. The thickness  $T_c$  of the carcass **35** is measured from the inner surface **32** to the ground-engaging outer

surface 31 of the carcass 35 between longitudinally-adjacent ones of the traction projections 58<sub>1</sub>-58<sub>T</sub>. For example, in some embodiments, the thickness T<sub>c</sub> of the carcass 35 may be no more than 0.25 inches, in some cases no more than 0.22 inches, in some cases no more than 0.20 inches, and in some cases even less (e.g., no more than 0.18 or 0.16 inches). The thickness T<sub>c</sub> of the carcass 35 may have any other suitable value in other embodiments.

[0051] Each of the drive wheels 22<sub>1</sub>, 22<sub>2</sub> is rotatable on an axle of the snowmobile 10 for driving the track 21. That is, power generated by the prime mover 15 and delivered over the powertrain 12 of the snowmobile 10 rotates the axle, which rotates the drive wheels 22<sub>1</sub>, 22<sub>2</sub>, which impart motion of the track 21. In this embodiment, each drive wheel 22<sub>i</sub> comprises a drive sprocket engaging some of the drive/guide lugs 34<sub>1</sub>-34<sub>D</sub> of the inner side 25 of the track 21 in order to drive the track 21. In other embodiments, the drive wheel 22<sub>i</sub> may be configured in various other ways. For example, in embodiments where the track 21 comprises drive holes, the drive wheel 22<sub>i</sub> may have teeth that enter these holes in order to drive the track 21. As yet another example, in some embodiments, the drive wheel 22<sub>i</sub> may frictionally engage the inner side 25 of the track 21 in order to frictionally drive the track 21. The drive wheels 22<sub>1</sub>, 22<sub>2</sub> may be arranged in other configurations and/or the track system 14 may comprise more or less drive wheels (e.g., a single drive wheel, more than two drive wheels, etc.) in other embodiments.

[0052] The idler wheels 26<sub>1</sub>-26<sub>4</sub>, 28<sub>1</sub>-28<sub>6</sub>, 30<sub>1</sub>, 30<sub>2</sub> are not driven by power supplied by the prime mover 15, but are rather used to do at least one of guiding the track 21 as it is driven by the drive wheels 22<sub>1</sub>, 22<sub>2</sub>, tensioning the track 21, and supporting part of the weight of the snowmobile 10 on the ground via the track 21. More particularly, in this embodiment, the rear idler wheels 26<sub>1</sub>-26<sub>4</sub> are trailing idler wheels that maintain the track 21 in tension, guide the track 21 as it wraps around them, and can help to support part of the weight of the snowmobile 10 on the ground via the track 21. The lower roller wheels 28<sub>1</sub>-28<sub>6</sub> roll on the inner side 25 of the track 21 along the bottom run 66 of the track 21 to apply the bottom run 66 on the ground. The upper roller wheels 30<sub>1</sub>, 30<sub>2</sub> roll on the inner side 25 of the track 21 along the top run 65 of the track 21 to support and guide the top run 65 as the track 21 moves. The idler wheels 26<sub>1</sub>-26<sub>4</sub>, 28<sub>1</sub>-28<sub>6</sub>, 30<sub>1</sub>, 30<sub>2</sub> may be arranged in other configurations and/or the track assembly 14 may comprise more or less idler wheels in other embodiments.

[0053] The slide rails 33<sub>1</sub>, 33<sub>2</sub> slide on the inner side 25 of the track 21 along the bottom run 66 of the track 21 to apply the bottom run 66 onto the ground. In this embodiment, the slide rails 33<sub>1</sub>, 33<sub>2</sub> are curved upwardly in a front region of the track system 14 to guide the track 21 towards the drive wheels 22<sub>1</sub>, 22<sub>2</sub>. In some cases, the track 21 may comprise slide members 39<sub>1</sub>-39<sub>S</sub> that slide against the slide rails 33<sub>1</sub>, 33<sub>2</sub> to reduce friction. The slide members 39<sub>1</sub>-39<sub>S</sub>, which can sometimes be referred to as “clips”, may be mounted via holes 40<sub>1</sub>-40<sub>H</sub> arranged in two rows extending longitudinally and spaced apart laterally of the track 21. In other cases, the track 21 may be free of such slide members. The slide rails 33<sub>1</sub>, 33<sub>2</sub> may be arranged in other configurations and/or the track assembly 14 may comprise more or less slide rails in other embodiments.

[0054] The traction projections 58<sub>1</sub>-58<sub>T</sub> are arranged on the ground-engaging outer side 27 of the track 21 to enhance traction of the track 21.

[0055] Respective ones of the traction projections 58<sub>1</sub>-58<sub>T</sub> (e.g., the traction projections 58<sub>1</sub>, 58<sub>2</sub>, 58<sub>3</sub>) are spaced apart in the longitudinal direction of the track 21. A longitudinal spacing S<sub>T</sub> of a traction projection 58<sub>i</sub> and a traction projection 58<sub>j</sub> that are spaced apart in the longitudinal direction of the track 21, which is a distance between a center C<sub>T,i,i</sub> of the traction projection 58<sub>i</sub> in the longitudinal direction of the track 21 and a center C<sub>T,j,i</sub> of the traction projection 58<sub>j</sub> in the longitudinal direction of the track 21, may have any suitable value.

[0056] In this embodiment, the traction projections 58<sub>1</sub>-58<sub>T</sub> are arranged in a plurality of rows 60<sub>1</sub>-60<sub>R</sub>, referred to as “traction projection rows”, that extend transversally to and are spaced apart in the longitudinal direction of the track 21. The ground-engaging outer side 27 comprises regions 62<sub>1</sub>-62<sub>F</sub> free of traction projections in between the traction projection rows 60<sub>1</sub>-60<sub>R</sub>, i.e., there are no traction projections like the traction projections 58<sub>1</sub>-58<sub>T</sub> projecting from the ground-engaging outer surface 31 of the carcass 35 in these “traction-projection-free” regions 62<sub>1</sub>-62<sub>F</sub>.

[0057] A longitudinal spacing S<sub>r</sub> of a traction projection row 60<sub>i</sub> and a traction projection row 60<sub>j</sub> that succeeds the traction projection row 60<sub>i</sub>, which is a distance between a center C<sub>r,i</sub> of the traction projection row 60<sub>i</sub> in the longitudinal direction of the track 21 and a center C<sub>r,j</sub> of the traction projection row 60<sub>j</sub> in the longitudinal direction of the track 21, may have any suitable value. For example, in some embodiments, the longitudinal spacing S<sub>r</sub> of the traction projection rows 60<sub>i</sub>, 60<sub>j</sub> may be at least 2.5 inches, in some cases at least 2.8 inches, in some cases at least 3 inches, and in some cases even more (e.g., at least 3.5 inches). In this example, the longitudinal spacing S<sub>r</sub> of adjacent ones of the traction projection rows 60<sub>1</sub>-60<sub>R</sub> is uniform such that the longitudinal spacing S<sub>r</sub> can be viewed as a “pitch” of the traction projection rows 60<sub>1</sub>-60<sub>R</sub>. In other examples, the longitudinal spacing S<sub>r</sub> of adjacent ones of the traction projection rows 60<sub>1</sub>-60<sub>R</sub> may vary along the track 21. Also, in this case, the longitudinal spacing S<sub>r</sub> of adjacent ones of the traction projection rows 60<sub>1</sub>-60<sub>R</sub> corresponds to the longitudinal spacing S<sub>T</sub> of traction projections 58<sub>i</sub>, 58<sub>j</sub> that are part of these rows. In other cases, the longitudinal spacing S<sub>r</sub> of adjacent ones of the traction projection rows 60<sub>1</sub>-60<sub>R</sub> may be different from the longitudinal spacing S<sub>T</sub> of traction projections 58<sub>i</sub>, 58<sub>j</sub> that are part of these rows, depending on shapes of these traction projections.

[0058] In this example of implementation, the traction projection rows 60<sub>1</sub>-60<sub>R</sub> are generally aligned in the longitudinal direction of the track 21 with the transversal stiffening rods 36<sub>1</sub>-36<sub>N</sub>. That is, each of the traction projection rows 60<sub>1</sub>-60<sub>R</sub> overlaps with a respective one of the transversal stiffening rods 36<sub>1</sub>-36<sub>N</sub> in the longitudinal direction of the track 21. A longitudinal spacing S<sub>s</sub> of a transversal stiffening rod 36<sub>i</sub> and a transversal stiffening rod 36<sub>j</sub> that succeeds the transversal stiffening rod 36<sub>i</sub>, which is a distance between a center C<sub>s,i</sub> of the transversal stiffening rod 36<sub>i</sub> in the longitudinal direction of the track 21 and a center C<sub>s,j</sub> of the transversal stiffening rod 36<sub>j</sub> in the longitudinal direction of the track 21, is thus related to the longitudinal spacing S<sub>r</sub> of the traction projection rows 60<sub>i</sub>, 60<sub>j</sub> located where the transversal stiffening rods 36<sub>i</sub>, 36<sub>j</sub> are located. For instance, in this case, the longitudinal spacing

$S_s$  of the transversal stiffening rods **36**, **36**, substantially corresponds to the longitudinal spacing  $S_r$  of the traction projection rows **60**, **60**. In other cases, the longitudinal spacing  $S_r$  of the transversal stiffening rods **36**, **36**, may differ from the longitudinal spacing  $S_r$  of the traction projection rows **60**, **60**. In other examples of implementation, one or more (e.g., possibly all) of the traction projection rows **60**-**60<sub>R</sub>** may not be aligned in the longitudinal direction of the track **21** with any one of the transversal stiffening rods **36**-**36<sub>N</sub>**, or the track **21** may be free of transversal stiffening rods.

**[0059]** Also, in this embodiment, respective ones of the traction projections **58**<sub>1</sub>-**58<sub>T</sub>** (e.g., the traction projections **58**<sub>1</sub>, **58**<sub>2</sub>) are distributed in the widthwise direction of the track **21**. Notably, in this embodiment, the traction projections **58**<sub>1</sub>-**58<sub>T</sub>** are arranged in a staggered arrangement in which given ones of the traction projections **58**<sub>1</sub>-**58<sub>T</sub>** are staggered relative to one another. This may help to enhance traction by providing large spaces **72**<sub>1</sub>-**72<sub>L</sub>** for containing snow and/or other ground matter between longitudinally-succeeding ones of the traction projections **58**<sub>1</sub>-**58<sub>T</sub>** which face one another and apply tractive forces on that snow and/or other ground matter.

**[0060]** More particularly, in this embodiment, a traction projection **58**<sub>i</sub> and a traction projection **58**<sub>j</sub> succeeding the traction projection **58**<sub>j</sub> in the longitudinal direction of the track **21** are offset from one another (i.e., nonaligned) in the widthwise direction of the track **21**. That is, a center  $C_{i,w}$  of the traction projection **58**<sub>i</sub> in the widthwise direction of the track **21** and a center  $C_{j,w}$  of the traction projection **58**<sub>j</sub> in the widthwise direction of the track **21** are spaced apart in the widthwise direction of the track **21** by a distance  $G_r$ . At least a majority (i.e., a majority or an entirety) of the traction projection **58**<sub>i</sub> does not overlap with the traction projection **58**<sub>j</sub> in the widthwise direction of the track **21**.

**[0061]** In addition, a traction projection **58**<sub>i</sub> and a traction projection **58**<sub>k</sub> that does not immediately follow the traction projection **58**<sub>i</sub> in the longitudinal direction of the track **21** are generally aligned with one another in the widthwise direction of the track **21**. That is, a center  $C_{i,w}$  of the traction projection **58**<sub>i</sub> in the widthwise direction of the track **21** and a center  $C_{k,w}$  of the traction projection **58**<sub>k</sub> in the widthwise direction of the track **21** are generally aligned in the widthwise direction of the track **21**. At least a majority (i.e., a majority or an entirety) of the traction projection **58**<sub>i</sub> overlaps with the traction projection **58**<sub>k</sub> in the widthwise direction of the track **21**.

**[0062]** In this example of implementation, the traction projections **58**<sub>1</sub>-**58<sub>T</sub>** define a traction projection pattern **70** that repeats itself at every two of the traction projection rows **60**<sub>1</sub>-**60<sub>R</sub>**. In other examples of implementation, the traction projection pattern **70** defined by the traction projections **58**<sub>1</sub>-**58<sub>T</sub>** may repeat itself at every three, four, five, or more of the traction projection rows **60**<sub>1</sub>-**60<sub>R</sub>**. In yet other examples of implementation, the traction projections **58**<sub>1</sub>-**58<sub>T</sub>** may not define any discernible pattern that repeats itself (e.g., every one of the traction projection rows **60**<sub>1</sub>-**60<sub>R</sub>** may have a unique configuration).

**[0063]** In this embodiment, the traction projections **58**<sub>1</sub>-**58<sub>T</sub>** are very high to enhance traction. Each traction projection **58**<sub>i</sub> has a height  $H_i$  which is measured from the ground-engaging outer surface **31** of the carcass **35** in the thickness direction of the track **21**. The height  $H_i$  of the traction projection **58**<sub>x</sub> is significantly greater than the thick-

ness  $T_c$  of the carcass **35**. For example, in some embodiments, a ratio  $H_i/T_c$  of the height  $H_i$  of the traction projection **58**<sub>x</sub> over the thickness  $T_c$  of the carcass **35** may be at least 15, in some cases at least 17, in some cases at least 20, in some cases at least 22, and in some cases even more (e.g., at least 25). For instance, in some embodiments, the height  $H_i$  of the traction projection **58**<sub>x</sub> may be greater than 3 inches, in some cases at least 3.5 inches, in some cases at least 3.75 inches, in some cases at least 4 inches, in some cases at least 4.25 inch, and in some cases even more (e.g., at least 4.5 inches or 5 inches). The height  $H_i$  of the traction projection **58**<sub>x</sub> and/or the ratio  $H_i/T_c$  of the height  $H_i$  of the traction projection **58**<sub>x</sub> over the thickness  $T_c$  of the carcass **35** may have any other suitable value in other embodiments.

**[0064]** The height  $H_i$  of the traction projection **58**<sub>x</sub>, which is significant, increases an effective tractive area  $A_t$  of the traction projection **58**<sub>x</sub> that applies tractive forces on the snow and/or other ground matter. The effective tractive area  $A_t$  of the traction projection **58**<sub>x</sub> can be calculated as a product of the height  $H_i$  of the traction projection **58**<sub>x</sub> and a length  $L_t$  of the traction projection **58**<sub>x</sub>.

**[0065]** Furthermore, in this example of implementation, the large spaces **72**<sub>1</sub>-**72<sub>L</sub>** between longitudinally-succeeding ones of the traction projections **58**<sub>1</sub>-**58<sub>T</sub>** that face one another provided by the staggered arrangement of the traction projections **58**<sub>1</sub>-**58<sub>T</sub>** may help to better utilize the effective tractive area  $A_t$  of each of the traction projections **58**<sub>1</sub>-**58<sub>T</sub>**. For instance, with additional reference to FIG. **8**, each of the larger spaces **72**<sub>1</sub>-**72<sub>L</sub>** may contain a mass of snow and/or other ground matter **75** that may be more suitably sized for tractive forces applied by the traction projections **58**<sub>1</sub>-**58<sub>T</sub>** than if it was smaller. In other words, the mass of snow and/or other ground matter **75** in each of the larger spaces **72**<sub>1</sub>-**72<sub>L</sub>** is both relatively deep (i.e., in the thickness direction of the track **21**) and relatively long (i.e., in the longitudinal direction of the track **21**) and may thus better handle tractive forces applied by the traction projections **58**<sub>1</sub>-**58<sub>T</sub>** compared to if it was as deep but shorter.

**[0066]** More particularly, in this embodiment, the height  $H_i$  of each traction projection **58**<sub>x</sub> is at least as great as the longitudinal spacing  $S_r$  of adjacent traction projection rows **60**<sub>i</sub>, **60**<sub>j</sub> (i.e.,  $H_i \geq S_r$ ). In this example of implementation, the height  $H_i$  of the traction projection **58**<sub>x</sub> is greater than the longitudinal spacing  $S_r$  of the adjacent traction projection rows **60**<sub>i</sub>, **60**<sub>j</sub>. For example, in some embodiments, a ratio  $H_i/S_r$  of the height  $H_i$  of the traction projection **58**<sub>x</sub> over the longitudinal spacing  $S_r$  of the adjacent traction projection rows **60**<sub>i</sub>, **60**<sub>j</sub> may be at least 1.1, in some cases at least 1.2, in some cases at least 1.3, and in some cases even more (e.g., at least 1.4 or more). The ratio  $H_i/S_r$  of the height  $H_i$  of the traction projection **58**<sub>x</sub> over the longitudinal spacing  $S_r$  of the adjacent traction projection rows **60**<sub>i</sub>, **60**<sub>j</sub> may have any other suitable value in other embodiments.

**[0067]** Since in this embodiment the longitudinal spacing  $S_s$  of adjacent transversal stiffening rods **36**<sub>i</sub>, **36**<sub>j</sub> is related to the longitudinal spacing  $S_r$  of adjacent traction projection rows **60**<sub>i</sub>, **60**<sub>j</sub>, the height  $H_i$  of each traction projection **58**<sub>x</sub> is at least as great as the longitudinal spacing  $S_s$  of the adjacent transversal stiffening rods **36**<sub>i</sub>, **36**<sub>j</sub> (i.e.,  $H_i \geq S_s$ ). In this example of implementation, the height  $H_i$  of the traction projection **58**<sub>x</sub> is greater than the longitudinal spacing  $S_s$  of the adjacent transversal stiffening rods **36**<sub>i</sub>, **36**<sub>j</sub>. For example, in some embodiments, a ratio  $H_i/S_s$  of the height  $H_i$  of the traction projection **58**<sub>x</sub> over the longitudinal spacing  $S_s$  of the

adjacent transversal stiffening rods  $36_i, 36_j$  may be at least 1.1, in some cases at least 1.2, in some cases at least 1.3, and in some cases even more (e.g., at least 1.4 or more). The ratio  $H_i/S_i$  of the height  $H_i$  of the traction projection  $58_x$  over the longitudinal spacing  $S_i$  of the adjacent transversal stiffening rods  $36_i, 36_j$  may have any other suitable value in other embodiments.

**[0068]** In this example of implementation, the height  $H_i$  of a traction projection  $58_i$  is at least as great as the longitudinal spacing  $S_i$  of the traction projection  $58_i$  and a traction projection  $58_j$  that succeeds the traction projection  $58_i$  in the longitudinal direction of the track  $21$  and that is offset from the traction projection  $58_i$  in the widthwise direction of the track  $21$  (i.e.,  $H_i \geq S_i$ ), in this case, the height  $H_i$  of the traction projection  $58_i$  is greater than the longitudinal spacing  $S_i$  of the longitudinally-successive widthwise-offset traction projections  $58_i, 58_j$ . For instance, in some embodiments, a ratio  $H_i/S_i$  of the height  $H_i$  of the traction projection  $58_i$  over the longitudinal spacing  $S_i$  of the longitudinally-successive widthwise-offset traction projections  $58_i, 58_j$  may be at least 1.1, in some cases at least 1.2, in some cases at least 1.3, and in some cases even more (e.g., at least 1.4 or more). The ratio  $H_i/S_i$  of the height  $H_i$  of the traction projection  $58_i$  over the longitudinal spacing  $S_i$  of the longitudinally-successive widthwise-offset traction projections  $58_i, 58_j$  may have any other suitable value in other embodiments.

**[0069]** Also, in this example of implementation, the height  $H_i$  of a traction projection  $58_i$  is at least as great as, and in this case greater than, a ratio  $S_i/N_r$  of (i) the longitudinal spacing  $S_i$  of the traction projection  $58_i$  and a traction projection  $58_k$  that is spaced apart from the traction projection  $58_i$  in the longitudinal direction of the track  $21$  and that is generally aligned with the traction projection  $58_i$  in the widthwise direction of the track  $21$  over (ii) a number of traction projection row transitions  $N_r$  from the traction projection  $58_i$  to the traction projection  $58_k$  (i.e.,  $H_i \geq S_i/N_r$ ). In this case, the number of traction projection row transitions  $N_r$  between the traction projections  $58_i, 58_k$  is two ( $N_r=2$ ), namely one transition from the traction projection row  $60_i$  to the traction projection row  $68_j$  and one transition from the traction projection row  $60_j$  to the traction projection row  $60_k$ . In other cases, the number of traction projection row transitions  $N_r$  from the traction projection  $58_i$  to the traction projection  $58_k$  may have any other suitable value. For instance, in some embodiments, a ratio  $H_i/(S_i/N_r)$  of the height  $H_i$  of the traction projection  $58_i$  over the ratio  $S_i/N_r$  of (i) the longitudinal spacing  $S_i$  of the traction projections  $58_i, 58_k$  over (ii) the number of traction projection row transitions  $N_r$  between the traction projections  $58_i, 58_k$  may be at least 1.1, in some cases at least 1.2, in some cases at least 1.3, and in some cases even more (e.g., at least 1.4 or more). The ratio  $H_i/(S_i/N_r)$  may have any other suitable value in other embodiments.

**[0070]** Accordingly, in this embodiment, the traction projections  $58_1-58_T$ , notably in view of their size and staggered arrangement, enhance traction of the track  $21$  on the ground.

**[0071]** In this embodiment, provision of the traction projections  $58_1-58_T$  can result in certain benefits for the carcass  $35$ .

**[0072]** For instance, in this embodiment, provision of the traction projections  $58_1-58_T$  allows the carcass  $35$  to be thinner. For example, in some embodiments, the thickness  $T_c$  of the carcass  $35$  may be no more than 0.20 inches, in

some cases no more than 0.18 inches, in some cases no more than 0.16 inches, and in some cases even less (e.g., 0.15 inches or less).

**[0073]** Also, in this embodiment, provision of the traction projections  $58_1-58_T$  allows one or more of the reinforcements  $45_1-45_P$  embedded in the rubber  $38$  of the carcass  $35$  to be better positioned.

**[0074]** For example, in some embodiments, with additional reference to FIG. 9, a reinforcement  $45_x$  extending in the longitudinal direction of the track  $21$ , such as the reinforcement  $45_y$  which is the layer of reinforcing fabric  $43$ , may be less deflected where a traction projection  $58_i$  is located (e.g., less “pulled” by the rubber  $41$  of the traction projection  $58_i$  during molding of the track  $21$ ). In FIG. 9, the carcass  $35$  is not to scale but rather enlarged in the thickness direction of the track  $21$  for ease of illustration and explanation.

**[0075]** For instance, in some embodiments, at least part of the reinforcement  $45_x$  may be located below an outer surface level  $80$  of the carcass  $35$  underneath (i.e., directly beneath) the traction projection  $58_i$ . The outer surface level  $80$  of the carcass  $35$  is that level defined by the ground-engaging outer surface  $31$  of the carcass  $35$ . More particularly, in this case, a segment  $92$  of the reinforcement  $45_x$  is below the outer surface level  $80$  of the carcass  $35$  underneath the traction projection  $58_i$ . A point  $R_b$  of the reinforcement  $45_x$  that is located between and spaced apart from extremities  $E_{r,1}, E_{r,2}$  of the traction projection  $58_i$  in the longitudinal direction of the track  $21$  is thus located below the outer surface level  $80$  of the carcass  $35$ . An extent  $K_R$  of the segment  $92$  of the reinforcement  $45_x$  in the longitudinal direction of the track  $21$  may have any suitable value. For example, in some embodiments, a ratio  $K_R/W_r$  of the extent  $K_R$  of the segment  $92$  of the reinforcement  $45_x$  in the longitudinal direction of the track  $21$  over a width  $W_r$  of the traction projection  $58_i$  in the longitudinal direction of the track  $21$  may be at least 10%, in some cases at least 15%, in some cases at least 20%, in some cases at least 25%, in some cases at least 30%, in some cases at least 40%, in some cases at least 50%, and in some cases even more (e.g., up to 100%). The point  $R_b$  of the reinforcement  $45_x$  may thus be spaced apart from the extremity  $E_{r,1}$  of the traction projection  $58_i$  by at least 10%, in some cases at least 15%, in some cases at least 20%, in some cases at least 25%, in some cases at least 30%, in some cases at least 40%, in some cases at least 50%, and in some cases even more.

**[0076]** In this example of implementation, the reinforcement  $45_x$  extends over the transversal stiffening rod  $36_i$  located where the traction projection  $58_i$  is located. As a result, in this case, part of the reinforcement  $45_x$  may extend above the outer surface level  $80$  of the carcass  $35$  where the traction projection  $58_i$  is located. In other cases, all of the reinforcement  $45_x$  may remain at or below the outer surface level  $80$  of the carcass  $35$  where the traction projection  $58_i$  is located (e.g., if the transversal stiffening rod  $36_i$  is smaller or if there is no transversal stiffening rod where the traction projection  $58_i$  is located).

**[0077]** In some embodiments, the reinforcement  $45_x$  may deflect over a smaller longitudinal extent underneath the traction projection  $58_i$ . For example, a gradient  $\beta$  of the reinforcement  $45_x$  underneath the traction projection  $58_i$  may be relatively high. The gradient  $\beta$  of the reinforcement  $45_x$  refers to a ratio  $\Delta L/\Delta H$  of a distance  $\Delta L$  between lowest and highest points  $R_l, R_h$  of the reinforcement  $45_x$  underneath the

traction projection  $58_i$  over a distance  $\Delta H$  between the lowest and highest points  $R_i$ ,  $R_j$  of the reinforcement  $45_x$  underneath the traction projection  $58_i$ . For instance, in some embodiments, the gradient  $\beta$  of the reinforcement  $45_x$  underneath the traction projection  $58_i$  may be at least 0.6, in some cases at least 0.65, in some cases at least 0.70, in some cases at least 0.75, and in some cases greater.

[0078] In some embodiments, the reinforcement  $45_x$  may be disposed such that a distance  $D_{e,t}$  in the thickness direction of the track  $21$  from the reinforcement  $45_x$  to the outer surface level  $80$  of the carcass  $35$  at the extremity  $E_{t,1}$  of the traction projection  $58_i$  substantially corresponds to a distance  $D_{e,n}$  in the thickness direction of the track  $21$  from the reinforcement  $45_x$  to the outer surface level  $80$  of the carcass  $35$  at a longitudinal midpoint  $M_{t,i}$  between the traction projection  $58_i$  and a traction projection  $58_j$  that succeeds the traction projection  $58_i$  in the longitudinal direction of the track  $21$ . For instance, in some embodiments, a ratio  $D_{e,t}/D_{e,n}$  of the distance  $D_{e,t}$  from the reinforcement  $45_x$  to the outer surface level  $80$  of the carcass  $35$  at the extremity  $E_{t,1}$  of the traction projection  $58_i$  over the distance  $D_{e,n}$  from the reinforcement  $45_x$  to the outer surface level  $80$  of the carcass  $35$  at the longitudinal midpoint  $M_{t,i}$  between the traction projections  $58_i$ ,  $58_j$  may be between 0.9 and 1.1, in some cases between 0.95 and 1.05, in some cases between 0.98 and 1.02, and in some cases even closer to or equal to 1. The ratio  $D_{e,t}/D_{e,n}$  may have any other suitable value in other embodiments.

[0079] In some embodiments, the reinforcement  $45_x$  and another reinforcement  $45_y$ , extending in the longitudinal direction of the track  $21$ , such as the reinforcement  $45_i$  which is the layer of reinforcing cables  $37_1$ - $37_{M_t}$ , may remain generally uniformly spaced apart from one another within the carcass  $35$ . For instance, the reinforcements  $45_x$ ,  $45_y$  may be disposed such that a distance  $V_{e,t}$  between them in the thickness direction of the track  $21$  at extremity  $E_{t,1}$  of the traction projection  $58_i$  substantially corresponds to a distance  $V_{e,n}$  between them in the thickness direction of the track  $21$  at the longitudinal midpoint  $M_{t,j}$  between the traction projection  $58_i$  and the traction projection  $58_j$  that succeeds the traction projection  $58_i$  in the longitudinal direction of the track  $21$ . For example, in some embodiments, a ratio  $V_{e,t}/V_{e,n}$  of the distance  $V_{e,t}$  between the reinforcements  $45_x$ ,  $45_y$  at the extremity  $E_{t,1}$  of the traction projection  $58_i$  over the distance  $V_{e,n}$  between the reinforcements  $45_x$ ,  $45_y$  at the longitudinal midpoint  $M_{t,j}$  between the traction projections  $58_i$ ,  $58_j$  may be between 0.9 and 1.1, in some cases between 0.95 and 1.05, in some cases between 0.98 and 1.02, and in some cases even closer to or equal to 1. The ratio  $V_{e,t}/V_{e,n}$  may have any other suitable value in other embodiments.

[0080] The track  $21$  may be manufactured in various ways. For example, in this embodiment, with additional reference to FIG. 10, an example of a process for manufacturing the track  $21$  will be discussed. In this example, the track  $21$  is manufactured by molding it in sections in a mold  $85$ . More particularly, in this example, the track  $21$  is manufactured by compression molding.

[0081] In this embodiment, the rubber  $38$  and the reinforcements  $45_1$ - $45_p$ , including the transversal stiffening rods  $36_1$ - $36_N$ , the layer of reinforcing cables  $37_1$ - $37_{M_t}$  and the layer of reinforcing fabric  $43$ , of the carcass  $35$  are provided in the mold  $85$ . For instance, in this example, a plurality of layers (e.g., sheets) of rubber  $77_1$ - $77_L$ , a ply of fabric  $78$ , and

a cable arrangement  $79$  may be layered onto one another into the mold  $85$  with the transversal stiffening rods  $36_1$ - $36_N$  placed at appropriate positions between respective ones of these layered elements. In some cases, the ply of fabric  $78$  or the cable arrangement  $79$  may have been previously embedded in rubber such that it is provided as a rubber-covered fabric or cable arrangement. The layered elements used to make the carcass  $35$  may have been previously produced using various processes (e.g., calendering). Collectively, the layers of rubber  $77_1$ - $77_L$  and, if present, the rubber of the ply of fabric  $78$  and/or the cable arrangement  $79$  will, upon curing, form part of the rubber  $38$  of the carcass  $35$ .

[0082] Also, in this embodiment, distinct pieces of rubber  $88_1$ - $88_W$  are placed in the mold  $85$  to form at least part of the traction projections  $58_1$ - $58_T$ . The distinct pieces of rubber  $88_1$ - $88_W$  are spaced apart from one another and positioned on the layered elements used to make the carcass  $35$  in order to provide at least part of the rubber  $41$  of the traction projections  $58_1$ - $58_T$ . For instance, the distinct pieces of rubber  $88_1$ - $88_W$  may be placed at locations of respective ones of the traction projections  $58_1$ - $58_T$  (e.g., in cavities of the mold  $85$ ). This may allow the layers of rubber  $77_1$ - $77_L$  to form the carcass  $35$  to be fewer in number and/or one or more of these layers to be thinner.

[0083] Furthermore, in this embodiment, the rubber  $42$  of the drive/guide lugs  $34_1$ - $34_D$  is provided in the mold  $85$ . For instance, in some embodiments, the rubber  $42$  of the drive/guide lugs  $34_1$ - $34_D$  may be provided by parts of an inner one of the layers of rubber  $77_1$ - $77_L$  used to make the carcass  $35$  which will migrate into cavities of the mold  $85$  to form the drive/guide lugs  $34_1$ - $34_D$  during molding. Alternatively, in some embodiments, distinct pieces of rubber  $89_1$ - $89_V$  may be placed in the mold  $85$  to form at least part of the drive/guide lugs  $34_1$ - $34_D$ , similarly to what is discussed above in respect of the distinct pieces of rubber  $88_1$ - $88_W$  to form at least part of the traction projections  $58_1$ - $58_T$ .

[0084] The mold  $85$  is then closed and heat and pressure are applied to consolidate the components of the track  $21$  inside the mold  $85$ , including curing their rubber. The mold  $85$  may be heated to various temperatures and may be subjected to various levels of pressure, depending on material properties and desired performance characteristics of the track  $21$ .

[0085] Once the molding operation is completed, the track  $21$  may be removed from the mold  $85$  and may be subject to one or more finishing operations (e.g., flash trimming, etc.)

[0086] The track  $21$  may be manufactured in any other suitable way in other embodiments.

[0087] While embodiments described above relate to a snowmobile, in other embodiments, any feature of any embodiment described above may be used in another type of off-road vehicle.

[0088] For example, in some embodiments, as shown in FIGS. 11 to 14, any feature of any embodiment described above may be used in an all-terrain vehicle (ATV)  $110$  comprising a set of track systems  $114_1$ - $114_4$  providing traction to the ATV on the ground. The ATV  $110$  comprises a prime mover  $112$  in a driving relationship with the track systems  $114_1$ - $114_4$  via the ATV's powertrain, a seat  $118$ , and a user interface  $120$ , which enable a user of the ATV  $110$  to ride the ATV  $110$  on the ground. In this case, the seat  $118$  is a straddle seat and the ATV  $110$  is usable by a single person such that the seat  $118$  accommodates only that person

driving the ATV 110. In other cases, the seat 118 may be another type of seat, and/or the ATV 110 may be usable by two individuals, namely one person driving the ATV 110 and a passenger, such that the seat 118 may accommodate both of these individuals (e.g., behind one another or side-by-side) or the ATV 110 may comprise an additional seat for the passenger. For example, in other embodiments, the ATV 110 may be a side-by-side ATV, sometimes referred to as a “utility terrain vehicle” or “UTV”. The user interface 120 comprises a steering device operated by the user to control motion of the ATV 110 on the ground. In this case, the steering device comprises handlebars. In other cases, the steering device may comprise a steering wheel or other type of steering element. Each of the front track systems 114<sub>1</sub>, 114<sub>2</sub> is pivotable about a steering axis of the ATV 110 in response to input of the user at the handlebars in order to steer the ATV 110 on the ground.

[0089] In this embodiment, each track system 114<sub>i</sub> is mounted in place of a ground-engaging wheel 113, that may otherwise be mounted to the ATV 110 to propel the ATV 110 on the ground. That is, the ATV 110 may be propelled on the ground by four ground-engaging wheels 113<sub>1</sub>-113<sub>4</sub> with tires instead of the track systems 114<sub>1</sub>-114<sub>4</sub>. Basically, in this embodiment, the track systems 114<sub>1</sub>-114<sub>4</sub> may be used to convert the ATV 110 from a wheeled vehicle into a tracked vehicle, thereby enhancing its traction and floatation on the ground.

[0090] Any feature described herein with respect to the track system 14 of the snowmobile 10, including its track 21, may be applied to a track system 114<sub>i</sub> of the ATV 110, including its track 121.

[0091] The snowmobile 10 and the ATV 110 considered above are examples of tracked recreational vehicles. While they can be used for recreational purposes, such tracked recreational vehicles may also be used for utility purposes in some cases.

[0092] Any feature of any embodiment described herein may be used in combination with any feature of any other embodiment described herein.

[0093] Certain additional elements that may be needed for operation of certain embodiments have not been described or illustrated as they are assumed to be within the purview of those of ordinary skill in the art. Moreover, certain embodiments may be free of, may lack and/or may function without certain elements that are not specifically disclosed herein.

[0094] Although various embodiments and examples have been presented, this was for the purpose of describing, but not limiting, the invention. Various modifications and enhancements will become apparent to those of ordinary skill in the art and are within the scope of the invention, which is defined by the appended claims.

#### 1.-44. (canceled)

45. A track of traction of a vehicle, the track being mountable around a plurality of wheels for driving and guiding the track around the wheels, the track being elastomeric to be flexible around the wheels, the track comprising:

- a ground-engaging outer surface;
- an inner surface opposite to the ground-engaging outer surface; and
- a plurality of traction projections projecting from the ground-engaging outer surface;

wherein: the track includes a plurality of layers of elastomeric material forming at least part of the ground-engaging outer surface and the inner surface; and the track includes a plurality of distinct pieces of elastomeric material separate from the layers of elastomeric material before molding of the track, consolidated with at least part of the layers of elastomeric material during the molding of the track, and forming at least part of respective ones of the traction projections.

46. The track of claim 45, comprising a reinforcement embedded between the ground-engaging outer surface and the inner surface.

47. The track of claim 46, wherein the reinforcement is a plurality of transversal stiffening rods extending transversally to a longitudinal direction of the track and spaced apart in the longitudinal direction of the track.

48. The track of claim 46, wherein: the reinforcement is a first reinforcement; and the track comprises a second reinforcement embedded between the ground-engaging outer surface and the inner surface and spaced from the first reinforcement in a thickness-wise direction of the track.

49. The track of claim 48, wherein: the first reinforcement is a plurality of transversal stiffening rods extending transversally to a longitudinal direction of the track and spaced apart in the longitudinal direction of the track; and the second reinforcement is a reinforcing fabric.

50. The track of claim 45, wherein a ratio of (i) a height of each traction projection of the traction projections over (ii) a thickness of the track from the ground-engaging outer surface to the inner surface is at least 15.

51. The track of claim 45, wherein a ratio of (i) a height of each traction projection of the traction projections over (ii) a thickness of the track from the ground-engaging outer surface to the inner surface is at least 20.

52. The track of claim 45, wherein a height of each traction projection of the traction projections is greater than 3 inches.

53. The track of claim 45, wherein a height of each traction projection of the traction projections is at least 3.5 inches.

54. The track of claim 45, wherein a thickness of the track from the ground-engaging outer surface to the inner surface is no more than 0.2 inches.

55. The track of claim 45, wherein: the traction projections are arranged in a plurality of traction-projection rows that are spaced apart in a longitudinal direction of the track; and a pattern of the traction projections repeats at every two or more of the traction-projection rows.

56. The track of claim 45, wherein: the track comprises a plurality of holes extending from the ground-engaging outer surface to the inner surface; and central ones of the traction projections are located between respective ones of the holes in a widthwise direction of the track.

57. The track of claim 45, wherein: the track comprises a plurality of holes extending from the ground-engaging outer surface to the inner surface; central ones of the traction projections are located between respective ones of the holes in a widthwise direction of the track; and lateral ones of the traction projections are located between the holes and lateral edges of the track in the widthwise direction of the track.

58. The track of claim 45, wherein the track comprises a plurality of drive/guide projections projecting from the inner surface.

**59.** The track of claim **58**, wherein respective ones of the drive/guide projections are arranged in a plurality of drive/guide-projection rows that extend along a longitudinal direction of the track and are spaced apart in widthwise direction of the track.

**60.** The track of claim **59**, wherein the drive/guide-projection rows include at least four drive/guide-projection rows.

**61.** A track of traction of a vehicle, the track being mountable around a plurality of wheels for driving and guiding the track around the wheels, the track being elastomeric to be flexible around the wheels, the track comprising:

- a ground-engaging outer surface;
- an inner surface opposite to the ground-engaging outer surface;
- a plurality of traction projections projecting from the ground-engaging outer surface; and
- a plurality of transversal stiffening rods extending transversally to a longitudinal direction of the track and spaced apart in the longitudinal direction of the track; wherein: the track includes a plurality of layers of elastomeric material forming at least part of the ground-engaging outer surface and the inner surface; the transversal stiffening rods are embedded between respective ones of the layers of elastomeric material; the track includes a plurality of distinct pieces of elastomeric material separate from the layers of elastomeric material before molding of the track, consolidated with at least part of the layers of elastomeric material during the molding of the track, and forming at least part of respective ones of the traction projections; and a ratio of (i) a height of each traction projection of the traction projections over (ii) a thickness of the track from the ground-engaging outer surface to the inner surface is at least 15.

**62.** A method of manufacturing a track for a vehicle, the track being mountable around a plurality of wheels for driving and guiding the track around the wheels, the track being elastomeric to be flexible around the wheels, the method comprising:

- providing a plurality of layers of elastomeric material in a mold;
- providing a plurality of distinct pieces of elastomeric material in the mold, the distinct pieces of elastomeric material being spaced apart from one another in a longitudinal direction of the track; and
- molding the track in the mold such that:
  - i. the layers of elastomeric material form at least part of an inner surface of the track and a ground-engaging outer surface of the track; and
  - ii. the distinct pieces of elastomeric material form at least part of respective ones of a plurality of traction projections projecting from the ground-engaging outer surface of the track.

**63.** The method of claim **62**, comprising providing a reinforcement in the mold, wherein the molding is such that the reinforcement is embedded between the ground-engaging outer surface and the inner surface of the track.

**64.** The method of claim **63**, wherein the reinforcement is a plurality of transversal stiffening rods extending transver-

sally to the longitudinal direction of the track and spaced apart in the longitudinal direction of the track.

**65.** The method of claim **63**, wherein: the reinforcement is a first reinforcement; the method comprises providing a second reinforcement in the mold; and the molding is such that the second reinforcement is embedded between the ground-engaging outer surface and the inner surface of the track and spaced from the first reinforcement in a thickness-wise direction of the track.

**66.** The method of claim **65**, wherein: the first reinforcement is a plurality of transversal stiffening rods extending transversally to the longitudinal direction of the track and spaced apart in the longitudinal direction of the track; and the second reinforcement is a reinforcing fabric.

**67.** The method of claim **62**, wherein a ratio of (i) a height of each traction projection of the traction projections over (ii) a thickness of the track from the ground-engaging outer surface to the inner surface is at least 15.

**68.** The method of claim **62**, wherein a ratio of (i) a height of each traction projection of the traction projections over (ii) a thickness of the track from the ground-engaging outer surface to the inner surface is at least 20.

**69.** The method of claim **62**, wherein a height of each traction projection of the traction projections is greater than 3 inches.

**70.** The method of claim **62**, wherein a height of each traction projection of the traction projections is at least 3.5 inches.

**71.** The method of claim **62**, wherein a thickness of the track from the ground-engaging outer surface to the inner surface is no more than 0.2 inches.

**72.** The method of claim **62**, wherein: the traction projections are arranged in a plurality of traction-projection rows that are spaced apart in a longitudinal direction of the track; and a pattern of the traction projections repeats at every two or more of the traction-projection rows.

**73.** The method of claim **62**, wherein: the track comprises a plurality of holes extending from the ground-engaging outer surface to the inner surface; and central ones of the traction projections are located between respective ones of the holes in a widthwise direction of the track.

**74.** The method of claim **62**, wherein: the track comprises a plurality of holes extending from the ground-engaging outer surface to the inner surface; central ones of the traction projections are located between respective ones of the holes in a widthwise direction of the track; and lateral ones of the traction projections are located between the holes and lateral edges of the track in the widthwise direction of the track.

**75.** The method of claim **62**, wherein the molding is such that the track comprises a plurality of drive/guide projections projecting from the inner surface.

**76.** The method of claim **75**, wherein respective ones of the drive/guide projections are arranged in a plurality of drive/guide-projection rows that extend along a longitudinal direction of the track and are spaced apart in widthwise direction of the track.

**77.** The method of claim **76**, wherein the drive/guide-projection rows include at least four drive/guide-projection rows.