



US006971465B1

(12) **United States Patent**
Veara

(10) **Patent No.:** **US 6,971,465 B1**
(45) **Date of Patent:** **Dec. 6, 2005**

(54) **RETRACTABLE STAND FOR SNOWMOBILES**

(76) Inventor: **Jason Veara**, P.O. Box 147, Unalakleet, AK (US) 99684

(*) Notice: Subject to any disclaimer, the term of this patent is extended or adjusted under 35 U.S.C. 154(b) by 14 days.

(21) Appl. No.: **10/683,997**

(22) Filed: **Oct. 14, 2003**

(51) **Int. Cl.**⁷ **B62H 1/04**

(52) **U.S. Cl.** **180/190; 280/299; 280/763.1**

(58) **Field of Search** 180/182, 190; 280/293, 298, 299, 304, 900; 248/503; 211/1.3; 293/111.1, 116, 117, 118

(56) **References Cited**

U.S. PATENT DOCUMENTS

2,469,909 A *	5/1949	Wickman et al.	280/47.41
3,747,778 A	7/1973	Collins, Jr.	
3,785,541 A *	1/1974	Sibley	224/408
3,830,455 A	8/1974	Brightly	
3,981,372 A	9/1976	Moreau	
3,990,593 A *	11/1976	Guger	414/458
4,417,746 A	11/1983	Baron	

4,643,396 A	2/1987	Beals	
5,599,002 A *	2/1997	Knutson	248/552
5,618,030 A *	4/1997	Eggert	254/131
5,873,552 A	2/1999	Skarp	
6,102,369 A	8/2000	Monger	
6,273,392 B1	8/2001	Birkhold	
6,502,844 B1	1/2003	Winland	
6,688,581 B2 *	2/2004	Leitner	254/131

* cited by examiner

Primary Examiner—Anne Marie Boehler

(74) *Attorney, Agent, or Firm*—John D. Gugliotta

(57) **ABSTRACT**

An apparatus is provided that raises the rear of a snowmobile while it is parked for purposes of storage, repair, and/or warming up. The apparatus is attached to the snowmobile and forms an integral part that goes everywhere with the snowmobile. An integral support rack slides out of the rear bumper of the snowmobile. Once fully extended, the user can lift the rear bumper and drop the support stand down to support the rear of the snowmobile in the air, in much the same manner as a kick stand on a bicycle works. The stand also has a supporting structure that folds out to provide a multipoint support system that prevents the snowmobile from tipping over.

5 Claims, 3 Drawing Sheets

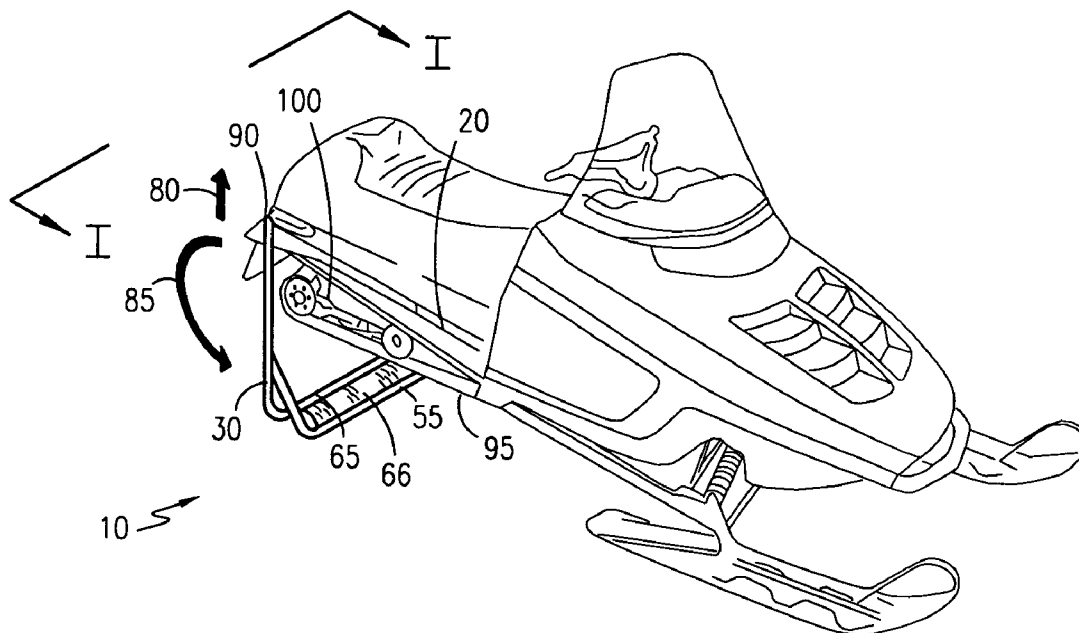

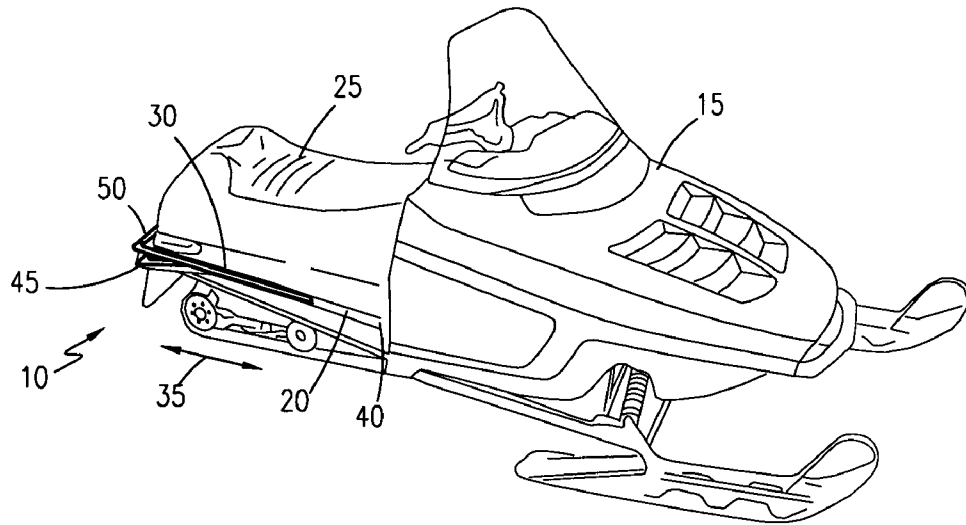

Fig. 1

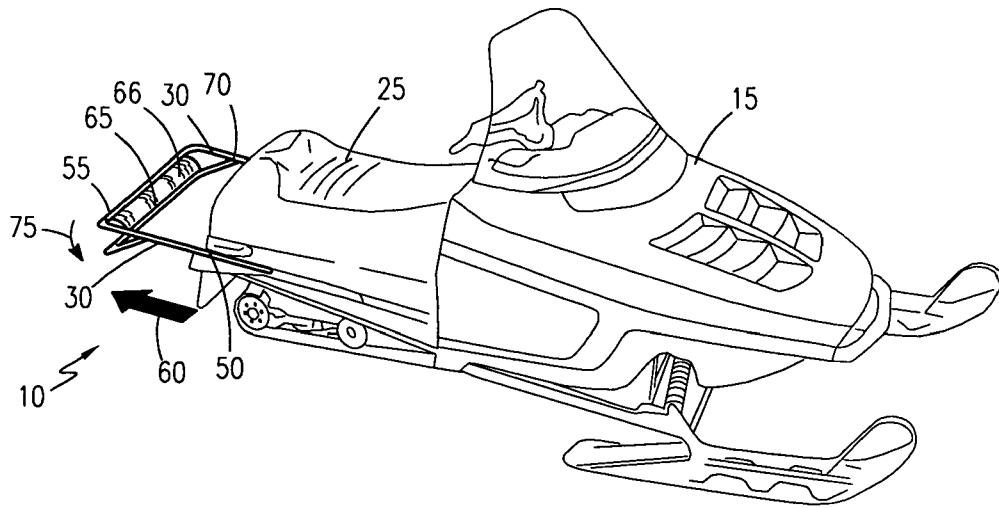

Fig. 2

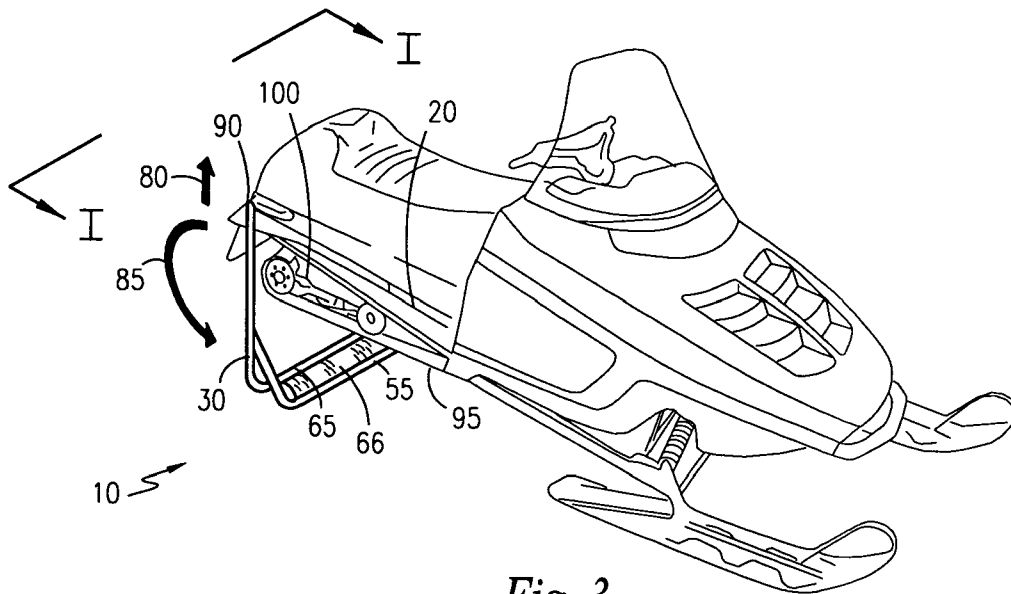

Fig. 3

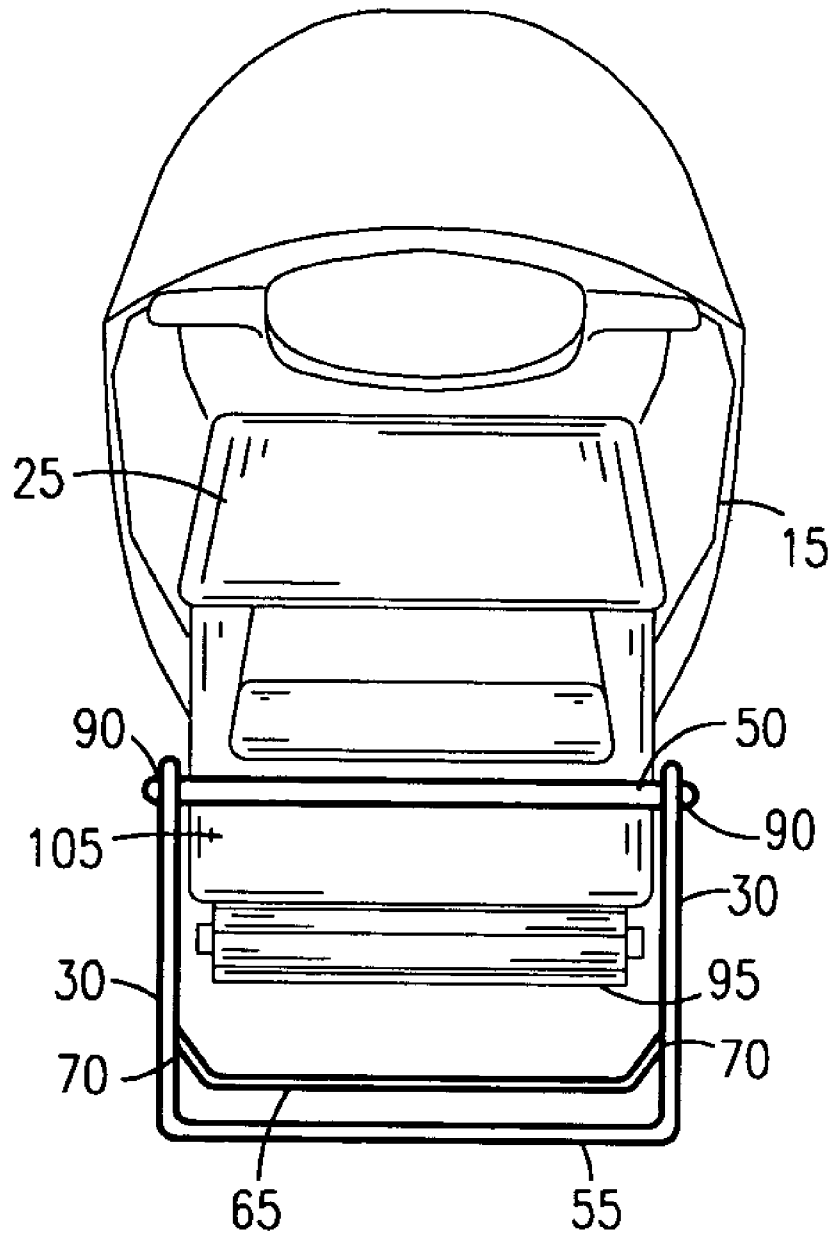

Fig. 4

1

RETRACTABLE STAND FOR SNOWMOBILES

RELATED APPLICATIONS

The present invention contains subject matter that was first described in Disclosure Document Registration 526,849 filed on Feb. 27, 2003 under 35 U.S.C. §122 and 37 C.F.R. §1.14. As such, it is respectfully requested that said Disclosure Document remain a permanent part of the file history of the present application and be relied upon during the pending prosecution, and for any other matters that may arise.

There are no previously filed, nor currently any co-pending applications, anywhere in the world.

FIELD OF THE INVENTION

The present invention relates generally to snow mobile accessories, and, more particularly, to a retractable stand for snowmobiles.

DESCRIPTION OF THE RELATED ART

Snowmobiles are not only recreational vehicles for many people, but they are also work vehicles as well. As such, people go to great lengths to care for them, protect them and prolong their useful life. One of the ways of accomplishing this is by the use of a snowmobile stand. A snowmobile stand raises up the rear of the snowmobile, thus allowing the belt to turn freely. This allows the engine and belt to warm up properly, thus improving engine performance and conserving fuel. The snowmobile stand also removes the weight of the snowmobile from the suspension thus prolonging its life. Finally, the stand makes snowmobile repair and maintenance much easier. However, the snowmobile stand is not always handy, and is certainly not available out on the trail, when it may be needed the most. Accordingly, there exists a need for a means by which the functionality of a snowmobile stand can be readily available without the disadvantages of a separate component.

A search of the prior art did not disclose any patents that read directly on the claims of the instant invention; however, the following references were considered related.

U.S. Pat. No. 6,102,369 describes a snowmobile jack stand.

U.S. Pat. No. 5,873,552 describes a snowmobile stand.

U.S. Pat. No. 3,830,455 also describes a snowmobile stand.

U.S. Pat. No. 6,273,392 describes a bicycle-supporting device of a bicycle stand.

U.S. Pat. No. 4,643,396 describes a stand for motorized snow vehicle or the like.

U.S. Pat. No. 3,747,778 describes a snowmobile hoist.

U.S. Pat. No. 3,981,372 describes a motorized snow vehicle stand.

U.S. Pat. No. 6,502,844 describes a motorcycle kickstand and detent mechanism.

U.S. Pat. No. 4,417,746 describes a kickstand for a motorcycle.

Consequently, a need has been felt for providing an apparatus and method of

SUMMARY OF THE INVENTION

It is therefore an object of the present invention to provide an improved support stand that retracts along snowmobile's lateral running boards when not in use.

2

It is a feature of the present invention to provide an improved a portable, retractable snowmobile support stand comprised of a generally C-shaped base support with a lower brace member pivotally mounted thereto, and an upper cross member bumper support for abutment against the bumper of a conventional snowmobile to facilitate inclined elevation thereof.

Briefly described according to one embodiment of the present invention, an apparatus is provided that raises the rear of a snowmobile while it is parked for purposes of storage, repair, and/or warming up. It is attached to the snowmobile and forms an integral part that goes everywhere with the snowmobile. An integral support rack slides out of the rear bumper of the snowmobile. Once fully extended, the user can lift the rear bumper and drop the support stand down to support the rear of the snowmobile in the air, in much the same manner as a kick stand on a bicycle works. The stand also has a supporting structure that folds out to provide a multipoint support system that prevents the snowmobile from tipping over.

The invention allows the user to warm up the snowmobile and its belt, perform maintenance, or even just keep the vehicle weight off of the snowmobile suspension during long periods of storage.

The use of the present invention greatly increases the ability to properly care for a snowmobile while remaining always handy and convenient for use.

BRIEF DESCRIPTION OF THE DRAWINGS

The advantages and features of the present invention will become better understood with reference to the following more detailed description and claims taken in conjunction with the accompanying drawings, in which like elements are identified with like symbols, and in which:

FIG. 1 is a pictorial view of the retractable stand for snowmobiles **10** shown in a stowed state on a snowmobile, according to a preferred embodiment of the present invention;

FIG. 2 is a pictorial view of the retractable stand for snowmobiles **10**, shown in a partially deployed state on a snowmobile;

FIG. 3 is a pictorial view of the retractable stand for snowmobiles **10**, shown in a utilized state on a snowmobile, and

FIG. 4 is a rear view of the retractable stand for snowmobiles **10** as taken along a line I—I as seen in FIG. 3.

DESCRIPTION OF THE PREFERRED EMBODIMENTS

The best mode for carrying out the invention is presented in terms of its preferred embodiment, herein depicted within the FIGS. 1 through 4.

1. Detailed Description of the Figures

Referring to FIG. 1, pictorial view of the retractable stand for snowmobiles **10** shown in a stowed state on a snowmobile **15**, according to a preferred embodiment of the present invention is disclosed. It is envisioned that the retractable stand for snowmobiles **10** can be preinstalled at the factory and be provided as a factory option, or the retractable stand for snowmobiles **10** can be provided as an aftermarket kit, suitable for installation on an existing snowmobile **15** by the final user. The components of the retractable stand for snowmobiles **10** are envisioned to be made of tube steel to suit the envisioned strength requirements. The retractable

3

stand for snowmobiles **10** consists of a slide channel **20** mounted below the seat area **25** of the snowmobile **15** in a horizontal fashion as shown. The slide channel **20** provides storage access for an upright support member **30** which slides in and out of the slide channel **20** as indicated by a first directional arrow **35**. When the upright support member **30** is at a forward end **40**, it is fully stowed. When the upright support member **30** is at an aft end **45** it is deployed. In the stowed position, the retractable stand for snowmobiles **10** allows full use and operation of the snowmobile **15** in a normal and customary manner. Additionally, in the stowed position, the upright support member **30** is incorporated into a rear bumper **50** as shown. It should be noted that the slide channel **20**, the upright support member **30**, the forward end **40**, and the aft end **45** are typical for each side of the snowmobile **15** and are symmetrical about the front rear axis of the snowmobile **15**.

Referring now to FIG. 2, a pictorial view of the retractable stand for snowmobiles **10**, in a partially deployed state on a snowmobile **15**, is depicted. This FIG. more clearly depicts the upright support member **30** on both the right and left side of the snowmobile **15**. A first cross member **55** is grasped by the user when the snowmobile **15** is stationary and is pulled in a rearward motion as depicted by a second directional arrow **60**. Once an adequate distance from the rear bumper **50** is achieved, a second cross member **65** drops down from the upright support member **30** and the first cross member **55** about a first pivot point **70** in a downward direction as depicted by a third directional arrow **75**. The second cross member **65** locks into place in its deployed condition and provides additional stability for the retractable stand for snowmobiles **10** and subsequently the snowmobile **15** when in use.

Referring next to FIG. 3, a pictorial view of the retractable stand for snowmobiles **10**, in a utilized state on a snowmobile **15**, is shown. In this FIG. the retractable stand for snowmobiles **10** is completely deployed. To achieve this position from the partially deployed position of FIG. 2, the user must lift the snowmobile **15** in a direction depicted by a fourth directional arrow **80**. This will allow the upright support member **30**, the first cross member **55** and the second cross member **65** to swing downward along a path depicted by a fifth directional arrow **85** which will place the upright support member **30** at an approximate right angle to the slide channel **20**. This rotation is accomplished by the use of a pair of second pivot points **90**, (of which only one is shown here for purposes of clarity), which are typically located on the previously forward end **40** of each upright support member **30**. Such a position allows a drive track **95** and suspension **100** to be raised up off of the surrounding grade, thus allowing the user to warm up the snowmobile **15** and its drive track **95**, or perform maintenance, or just keep the rear weight of the snowmobile **15** off of the suspension **100** during long periods of storage. A flexible plate **66**, envisioned as a KEVLAR™, nylon, or canvas type material flexibly spans between the first cross member **55** and second cross member **65** to provide a significant enough footprint to prevent the retractable stand from penetrating into snow if the stand is being used under outdoor conditions.

Referring finally to FIG. 4, a rear view of the retractable stand for snowmobiles **10** as taken along a line I—I as seen in FIG. 3 is disclosed. This FIG. more clearly shows the orientation of the retractable stand for snowmobiles **10** when viewed from the rear of the snowmobile **15**. The pair of upright support members **30** extend downward from the rear bumper **50** as held in place by the pair of second pivot points **90**. The upright support members **30** are interconnected by

4

the first cross member **55**, with the second cross member **65** attaching to the upright support members **30** via the first pivot point **70**. This configuration allows adequate access for both the first cross member **55** and the second cross member **65** to clear not only the drive track **95**, but a rear snow flap **105**, should the snowmobile **15** be so equipped. The triangle shaped structure formed by the first cross member **55**, the upright support member **30** and the second cross member **65**, form a stable base upon which the snowmobile **15** may rest, which is not subject to tipping over, yet easily stowed when no longer needed.

It is envisioned that other styles and configurations of the present invention can be easily incorporated into the teachings of the present invention, and only one particular configuration shall be shown and described for purposes of clarity and disclosure and not by way of limitation of scope.

2. Operation of the Preferred Embodiment

The preferred embodiment of the present invention can be utilized by the common user in a simple and effortless manner with little or no training. Users of the present embodiment of the current invention, have the option of buying a snowmobile **15** with the retractable stand for snowmobiles **10** preinstalled, or may purchase the retractable stand for snowmobiles **10** in a kit format for installation on an existing snowmobile **15**. After such installation or purchase, the retractable stand for snowmobiles **10** is ready for use.

To use the present invention, the user would first stop or park the snowmobile **15** in a desired location. This can be a permanent storage location such as a garage, driveway or shed, or can be a temporary storage location such as a store, campsite, or trail side. Once stopped, the user will walk to the rear of the snowmobile **15** and pull the first cross member **55** outward and away from the seat area **25** of the snowmobile **15**. During this process, the two upright support member **30** will slide along the slide channel **20**. Additionally, once the first pivot point **70** clears the slide channel **20**, the first pivot point **70** will allow the second cross member **65** to fall away from the first cross member **55** forming an auxiliary support for the retractable stand for snowmobiles **10**. When the upright support member **30** and associated first cross member **55** are fully extended, the user will lift up on the rear of the snowmobile **15** which will raise the drive track **95** up and off of the surrounding grade. Simultaneously, each upright support member **30** will fold down about its respective second pivot point **90** and lock into place thus providing a supporting frame for the snowmobile **15**. In such a manner, maintenance or repairs may be made to the snowmobile **15**, weight may be removed from the suspension **100** or simply, the snowmobile **15** and drive track **95** may be warmed up in extremely cold environments. The retractable stand for snowmobiles **10** may remain in this configuration for minutes or months depending on the needs of the user.

When the time arrives that the services of the retractable stand for snowmobiles **10** are no longer required, the user simply lifts up on the snowmobile **15** again, thus relieving the supporting pressure on the retractable stand for snowmobiles **10**. When elevated, the user will move the upright support member **30** backward. Once no longer in a perpendicular position to the grade, the snowmobile **15** can be lowered and supported on its drive track **95** and suspension **100**. In this position, the first cross member **55** and the second cross member **65** are raised up about the second pivot point **90** until the upright support member **30** is in a parallel position to the grade. The first cross member **55** is then

5

pushed inward so that the upright support member **30** slides along its respective slide channel **20**, the second cross member **65** will automatically fold up about the first pivot point **70**, such that it is completely stowed in the slide channel **20** and the first cross member **55** and the second cross member **65** is in contact with the rear bumper **50**. At this point, the retractable stand for snowmobiles **10** is stowed, allowing use of the snowmobile **15** in a conventional manner until the features of the retractable stand for snowmobiles **10** are required again.

The foregoing descriptions of specific embodiments of the present invention have been presented for purposes of illustration and description. They are not intended to be exhaustive or to limit the invention to the precise forms disclosed, and obviously many modifications and variations are possible in light of the above teaching. The embodiments were chosen and described in order to best explain the principles of the invention and its practical application, to thereby enable others skilled in the art to best utilize the invention and various embodiments with various modifications as are suited to the particular use contemplated. It is intended that the scope of the invention be defined by the Claims appended hereto and their equivalents. Therefore, the scope of the invention is to be limited only by the following claims.

What is claimed is:

1. A retractable support stand for a snowmobile comprising:

- a slide channel mounted below a seat area the snowmobile in a horizontal fashion;
- an upright support member telescopingly mounted with said slide channel such that when said upright support member is at a forward end, it is fully stowed, and when said upright support member is at an aft end it is deployed and pivotally to such a position as to allow a snowmobile's drive track and suspension to be raised up off of the surrounding grade, wherein said upright

6

support member terminates with a flexible plate spanning between a first cross member and a second cross member to provide a significant enough footprint to prevent the retractable stand from penetrating into snow if the stand is being used under outdoor conditions.

2. The retractable support stand for a snowmobile of claim **1**, wherein said flexible plate is selected from the group comprising KEVLAR™, nylon, and canvas type material.

3. The retractable support stand for a snowmobile of claim **1**, wherein said upright support member is further incorporated into a rear bumper.

4. In a snowmobile, the improvement comprising:

a snowmobile bumper in combination with a retractable support stand concealably deployable from said bumper, wherein said retractable support stand comprises:

a slide channel mounted below a seat area the snowmobile in a horizontal fashion;

an upright support member telescopingly mounted with said slide channel such that when said upright support member is at a forward end, it is fully stowed, and when said upright support member is at an aft end it is deployed and pivotally to such a position as to allow a snowmobile's drive track and suspension to be raised up off of the surrounding grade wherein said upright support member terminates with a flexible plate spanning between a first cross member and a second cross member to provide a significant enough footprint to prevent the retractable stand from penetrating into snow if the stand is being used under outdoor conditions.

5. The improvement of claim **4**, wherein said flexible plate is selected from the group comprising KEVLAR™, nylon, and canvas type material.

* * * * *