



US009365232B2

(12) **United States Patent**
Wrightman

(10) **Patent No.:** **US 9,365,232 B2**
(45) **Date of Patent:** ***Jun. 14, 2016**

(54) **SNOWMOBILE AND SUSPENSION ASSEMBLY THEREFOR**

(71) Applicant: **Robert A. Wrightman**, Bracebridge (CA)

(72) Inventor: **Robert A. Wrightman**, Bracebridge (CA)

(*) Notice: Subject to any disclaimer, the term of this patent is extended or adjusted under 35 U.S.C. 154(b) by 40 days.

This patent is subject to a terminal disclaimer.

(21) Appl. No.: **14/185,336**

(22) Filed: **Feb. 20, 2014**

(65) **Prior Publication Data**

US 2014/0291948 A1 Oct. 2, 2014

Related U.S. Application Data

(63) Continuation of application No. 13/221,293, filed on Aug. 30, 2011, now Pat. No. 8,690,182, which is a continuation-in-part of application No. 12/046,991, filed on Mar. 12, 2008, now Pat. No. 8,376,389, said application No. 13/221,293 is a continuation-in-part of application No. 12/906,776, filed on Oct. 18, 2010, now abandoned.

(60) Provisional application No. 60/894,252, filed on Mar. 12, 2007, provisional application No. 61/252,411, filed on Oct. 16, 2009.

(30) **Foreign Application Priority Data**

Oct. 22, 2007 (CA) 2604041

(51) **Int. Cl.**
B62B 17/02 (2006.01)
B62M 27/02 (2006.01)

(52) **U.S. Cl.**

CPC **B62B 17/02** (2013.01); **B62M 27/02** (2013.01); **B62M 2027/025** (2013.01); **B62M 2027/026** (2013.01)

(58) **Field of Classification Search**

CPC B62B 17/02; B62B 13/06; B62B 13/18; B62B 19/00; B62B 19/02; B62B 19/04; B62M 27/02; B62M 2027/025; B62M 2027/026

See application file for complete search history.

(56) **References Cited**

U.S. PATENT DOCUMENTS

573,034	A	12/1896	Peterson	
1,359,254	A *	11/1920	Krupsky	280/14
1,521,818	A	6/1925	Katona	
1,768,046	A	6/1930	Fredrickson et al.	
2,864,624	A *	12/1958	Lindelof et al.	280/11
3,181,879	A	5/1965	Hodges	
3,482,849	A	12/1969	Puetz	
3,525,412	A	8/1970	Erickson	

(Continued)

FOREIGN PATENT DOCUMENTS

CA	2605619	A1	4/2008
CA	2604041	C	3/2009

Primary Examiner — Paul N Dickson

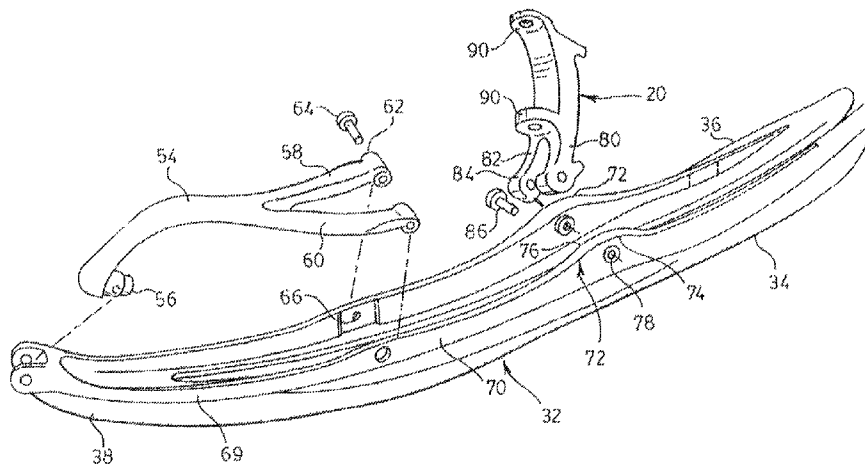
Assistant Examiner — Steve Clemmons

(74) *Attorney, Agent, or Firm* — Blake, Cassels & Graydon LLP; John R. S. Orange

(57) **ABSTRACT**

A snowmobile ski comprises a body having a pair of rails laterally spaced from one another and interconnected at a tip. A spindle assembly connects the ski to suspension elements of the snowmobile. The spindle assembly has a pair of legs connected to respective rails to allow snow to pass between the legs.

10 Claims, 23 Drawing Sheets



(56)

References Cited

U.S. PATENT DOCUMENTS

			7,422,083 B2	9/2008	Yoshihara et al.	
			7,481,437 B2	1/2009	Musselman	
			7,487,975 B2	2/2009	Pryputniewicz	
			7,581,609 B2	9/2009	Kubota	
			7,775,313 B1	8/2010	Sampson et al.	
			8,029,004 B2	10/2011	Lemieux	
			8,037,961 B2	10/2011	Fecteau	
			8,302,721 B2	11/2012	Yoshihara et al.	
			8,360,449 B2	1/2013	Polakowski et al.	
3,605,926 A	9/1971	Leonawicz	2001/0022435 A1	9/2001	Cormican	
3,613,809 A	10/1971	Chaumont	2001/0032744 A1	10/2001	Moriyama	
3,643,978 A	2/1972	Westberg	2002/0036387 A1	3/2002	Lemieux	
3,693,992 A	9/1972	Piedboeuf	2002/0056966 A1	5/2002	Cormican	
3,718,341 A	2/1973	Westberg	2002/0074752 A1	6/2002	Noble	
3,785,665 A	1/1974	Merenheim et al.	2002/0149174 A1	10/2002	Cormican	
3,786,886 A	1/1974	Bombardier	2003/0019676 A1	1/2003	Mallette et al.	
3,817,544 A	6/1974	Labelle	2003/0151216 A1	8/2003	Takahiko	
3,844,367 A	10/1974	Flohr	2003/0160405 A1	8/2003	Bruns	
3,857,578 A	12/1974	Alton	2003/0189302 A1	10/2003	Makitalo	
3,866,933 A	2/1975	Mollring	2003/0234500 A1	12/2003	Roberts et al.	
3,877,713 A	4/1975	Mabie et al.	2004/0099458 A1	5/2004	Meunier et al.	
3,897,839 A	8/1975	Brisebois	2004/0227312 A1*	11/2004	Dick et al.	280/28
3,942,812 A	3/1976	Kozlow	2005/0045397 A1	3/2005	Vaisanen	
3,977,485 A	8/1976	West et al.	2005/0072613 A1	4/2005	Maltais et al.	
4,077,639 A	3/1978	Reedy	2005/0103546 A1	5/2005	Bedard	
4,340,241 A	7/1982	Crocket	2005/0103547 A1	5/2005	Mallette et al.	
4,352,501 A	10/1982	Takagi	2005/0121244 A1	6/2005	Mallette et al.	
4,374,591 A	2/1983	Kobayashi	2005/0205320 A1	9/2005	Girouard et al.	
4,433,856 A	2/1984	Yoshida	2005/0205322 A1	9/2005	Girouard et al.	
4,491,333 A	1/1985	Warnke	2005/0252705 A1	11/2005	Abe et al.	
4,591,173 A	5/1986	Marier	2006/0032686 A1	2/2006	Berg	
4,593,921 A	6/1986	Marier	2006/0033294 A1	2/2006	Roberts et al.	
5,038,882 A	8/1991	Zulawski	2006/0061051 A1	3/2006	Lemieux	
5,109,941 A	5/1992	Thompson	2006/0061052 A1	3/2006	Lemieux	
5,209,505 A	5/1993	Bastile et al.	2006/0076742 A1	4/2006	Scholl	
5,242,176 A	9/1993	Hendrickson	2006/0081407 A1	4/2006	Vaisanen	
5,344,168 A	9/1994	Olson et al.	2006/0145534 A1*	7/2006	Musselman	305/191
5,443,278 A	8/1995	Berto	2006/0163826 A1	7/2006	Huntimer et al.	
5,836,594 A	11/1998	Simmons	2006/0175777 A1	8/2006	Lemieux et al.	
6,039,136 A	3/2000	Kanan	2006/0185920 A1	8/2006	Hibbert et al.	
6,105,979 A	8/2000	Desrochers	2007/0069487 A1	3/2007	Lemieux et al.	
6,276,699 B1	8/2001	Simmons et al.	2007/0090614 A1	4/2007	Pryputniewicz	
6,378,889 B1	4/2002	Moriyama	2007/0176388 A1	8/2007	Yoshihara et al.	
6,431,561 B1	8/2002	Hedlund	2007/0182111 A1	8/2007	Lachance	
6,520,512 B1	2/2003	Lachance	2007/0193799 A1	8/2007	Yoshihara et al.	
D473,488 S	4/2003	Mallette et al.	2007/0257453 A1	11/2007	Lemieux et al.	
D478,841 S	8/2003	Bruns	2007/0267847 A1	11/2007	Carlson et al.	
D480,332 S	10/2003	Cormican	2008/0173491 A1	7/2008	Fecteau	
6,655,487 B2*	12/2003	Mallette et al.	2008/0303228 A1	12/2008	Wrightman	180/190
6,692,009 B2	2/2004	Lemieux	2010/0129147 A1	5/2010	Wrightman	
6,702,304 B2	3/2004	Chu	2010/0288572 A1	11/2010	Maltais	
6,705,620 B2	3/2004	Bruns	2011/0079970 A1	4/2011	Pryputniewicz	
6,772,061 B1	8/2004	Berthiaume et al.	2011/0089649 A1	4/2011	Wrightman	
6,793,030 B2	9/2004	Pyykonen	2011/0115180 A1	5/2011	Polakowski	
6,860,352 B2	3/2005	Mallette et al.	2011/0115180 A1	5/2011	Polakowski	
6,942,050 B1	9/2005	Honkala	2011/0278083 A1	11/2011	Yoshihara et al.	
6,955,237 B1	10/2005	Przekwas et al.	2012/0104709 A1	5/2012	Wrightman	
6,976,550 B2	12/2005	Vaisanen	2013/0032417 A1	2/2013	Sampson	
RE39,012 E	3/2006	Noble et al.	2013/0032418 A1	2/2013	Ripley	
7,017,695 B2	3/2006	Meunier et al.	2013/0032419 A1	2/2013	Conn et al.	
7,124,847 B2	10/2006	Girouard	2013/0032420 A1	2/2013	Mills et al.	
7,124,848 B2	10/2006	Girouard				
7,195,254 B2	3/2007	Makitalo				
7,198,126 B2	4/2007	Vaisanen				
7,264,250 B2*	9/2007	Lachance				280/28
7,287,763 B1	10/2007	Beaudoin				
7,374,188 B2	5/2008	Hibbert				
7,410,182 B1	8/2008	Giese et al.				

* cited by examiner

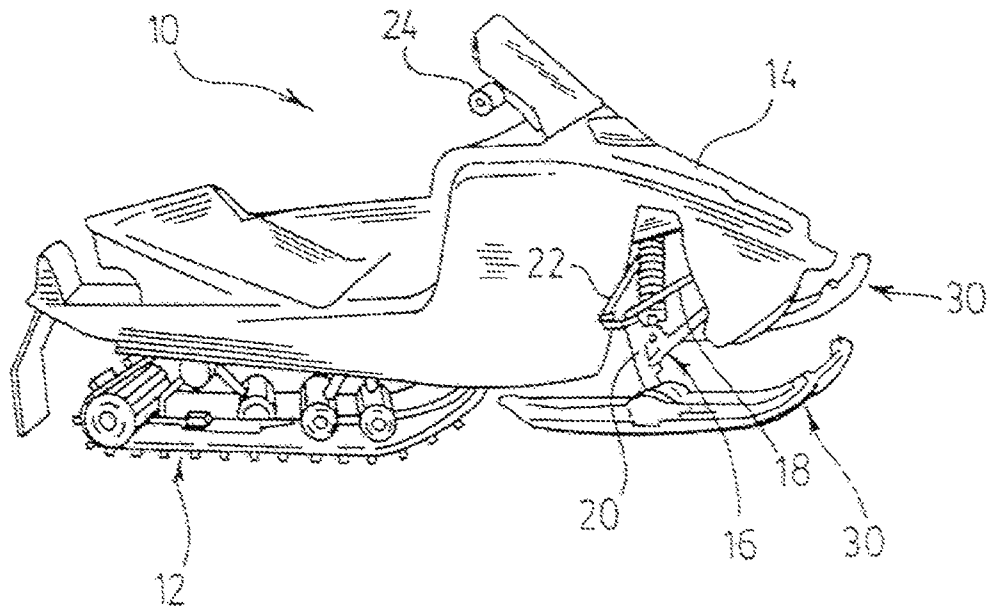


FIG. 1.

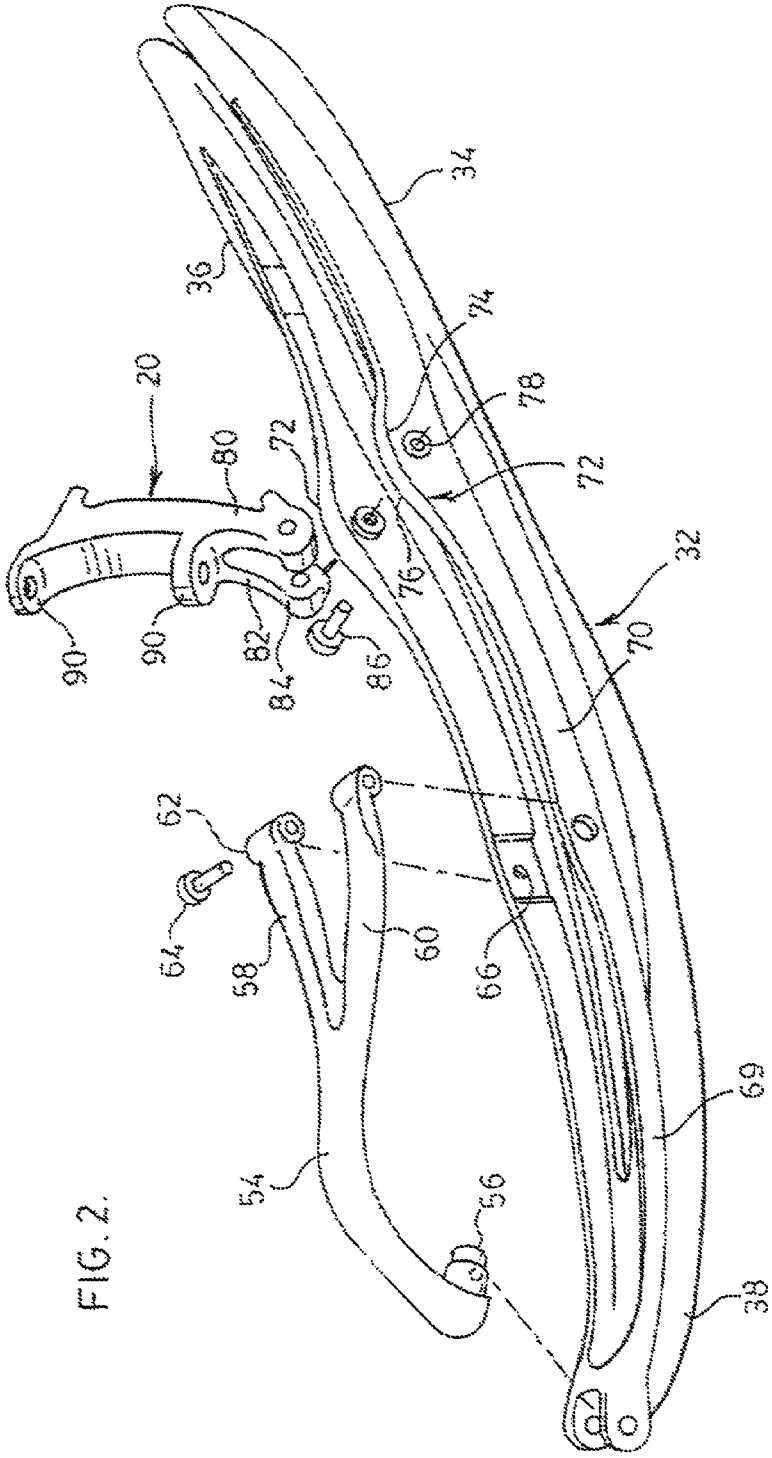
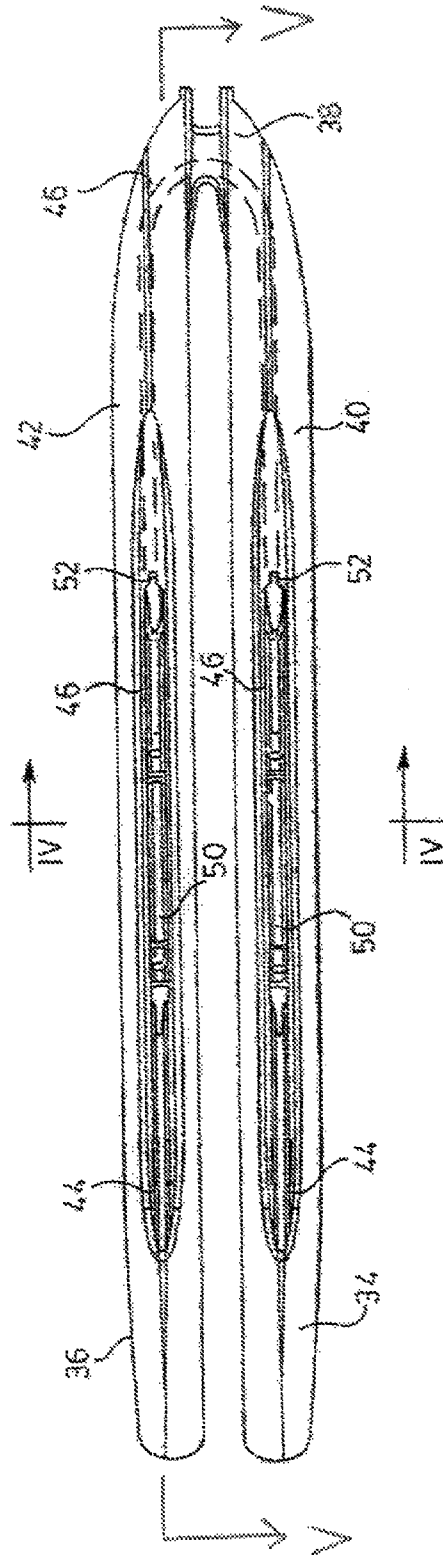
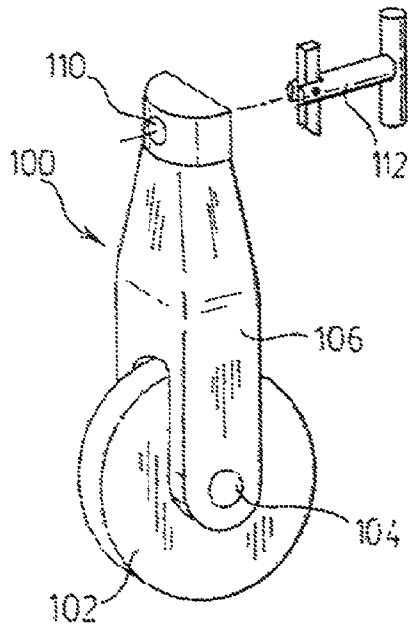
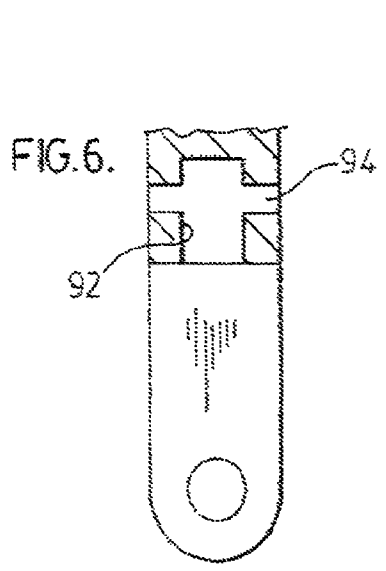
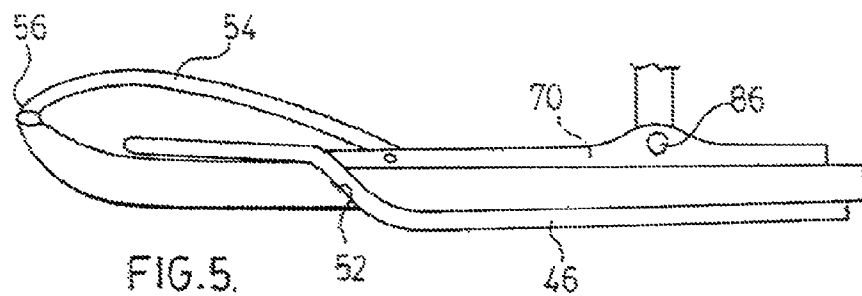
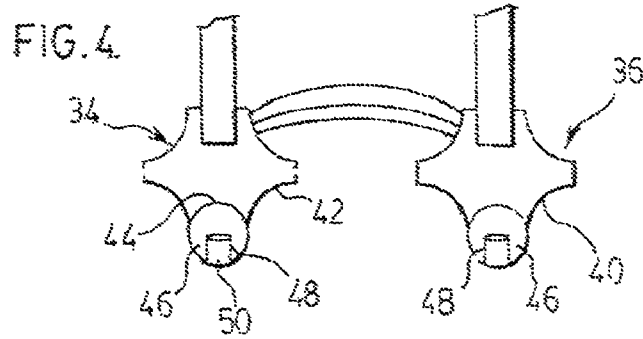
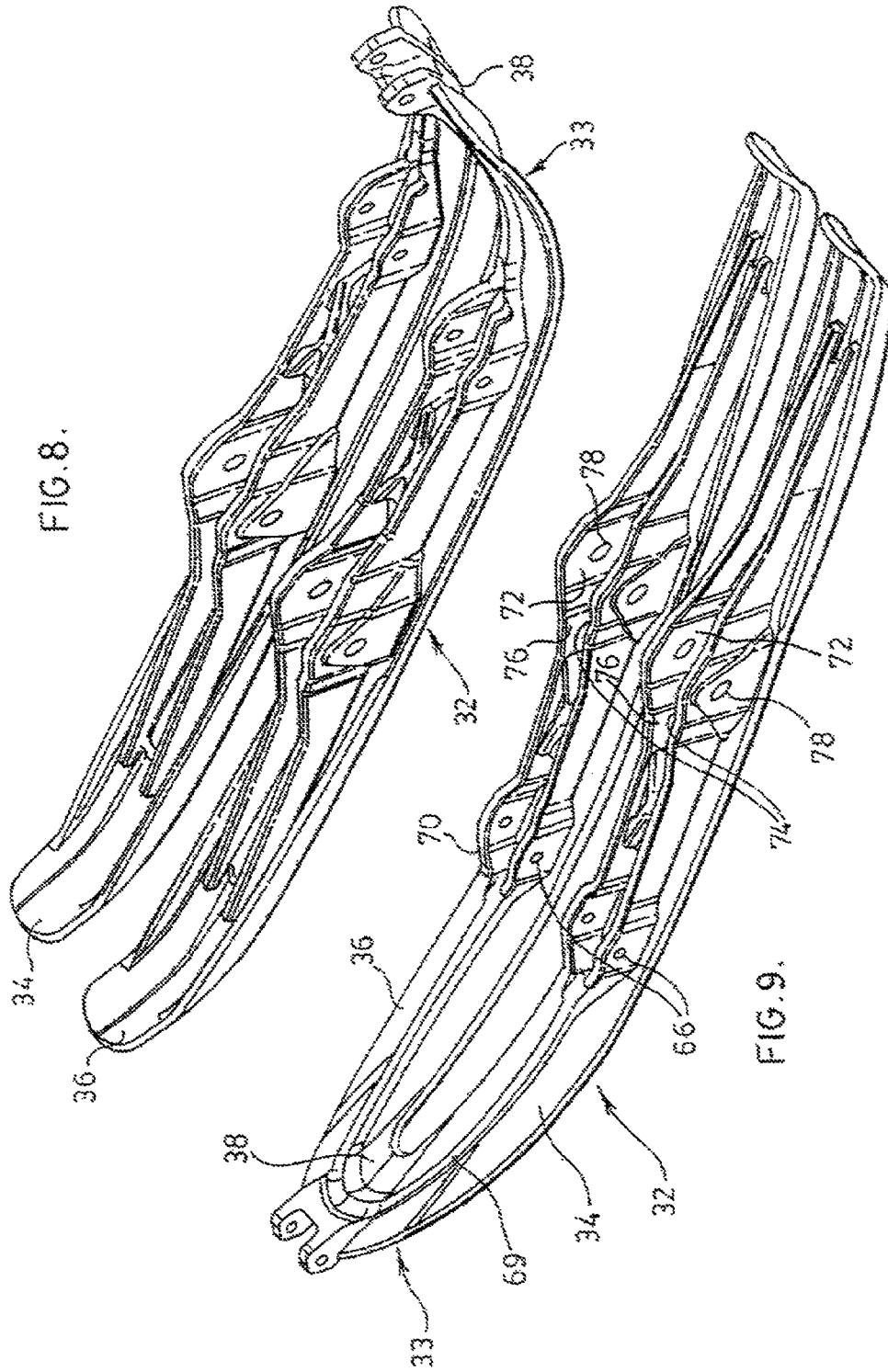
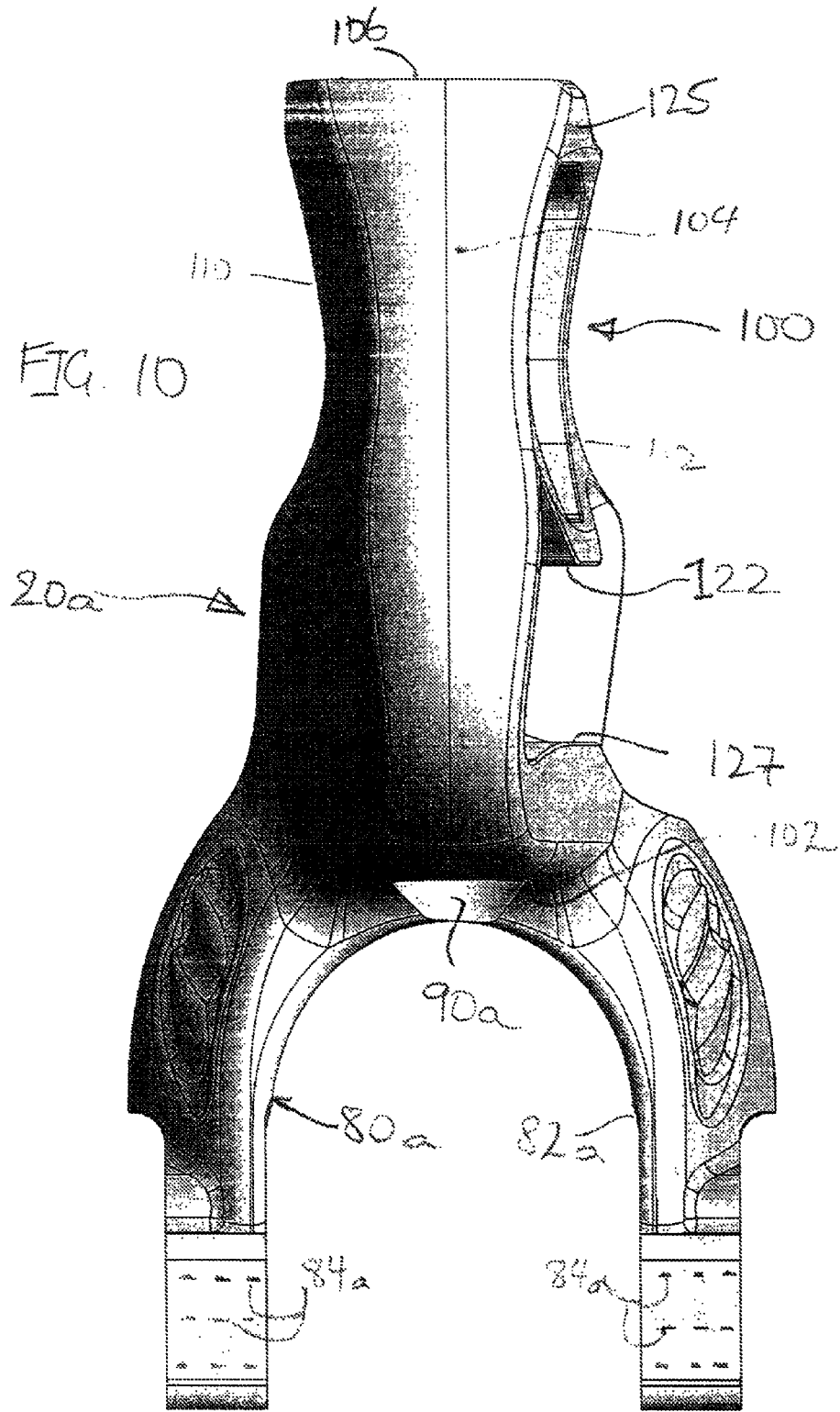


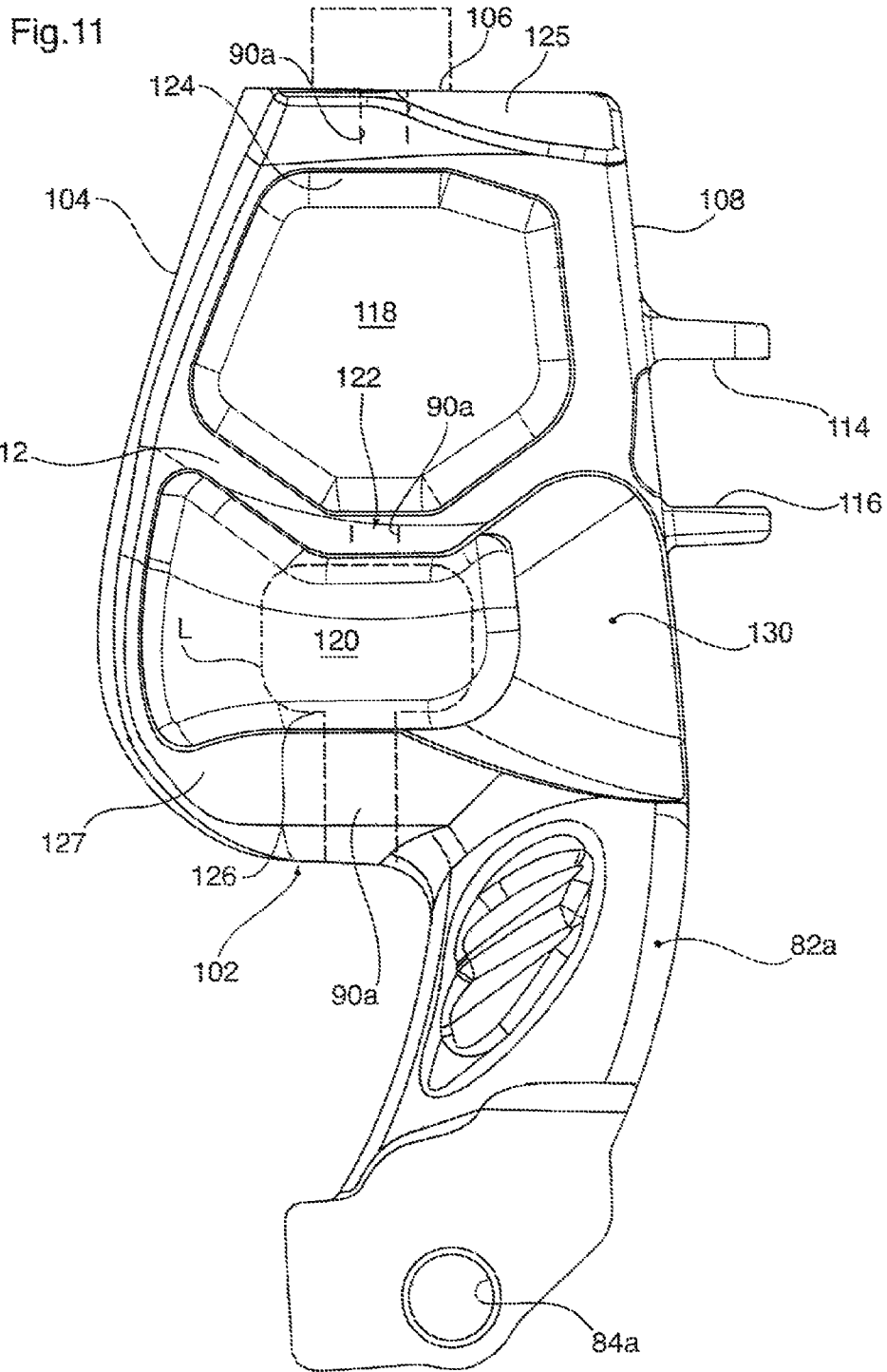
FIG. 3.

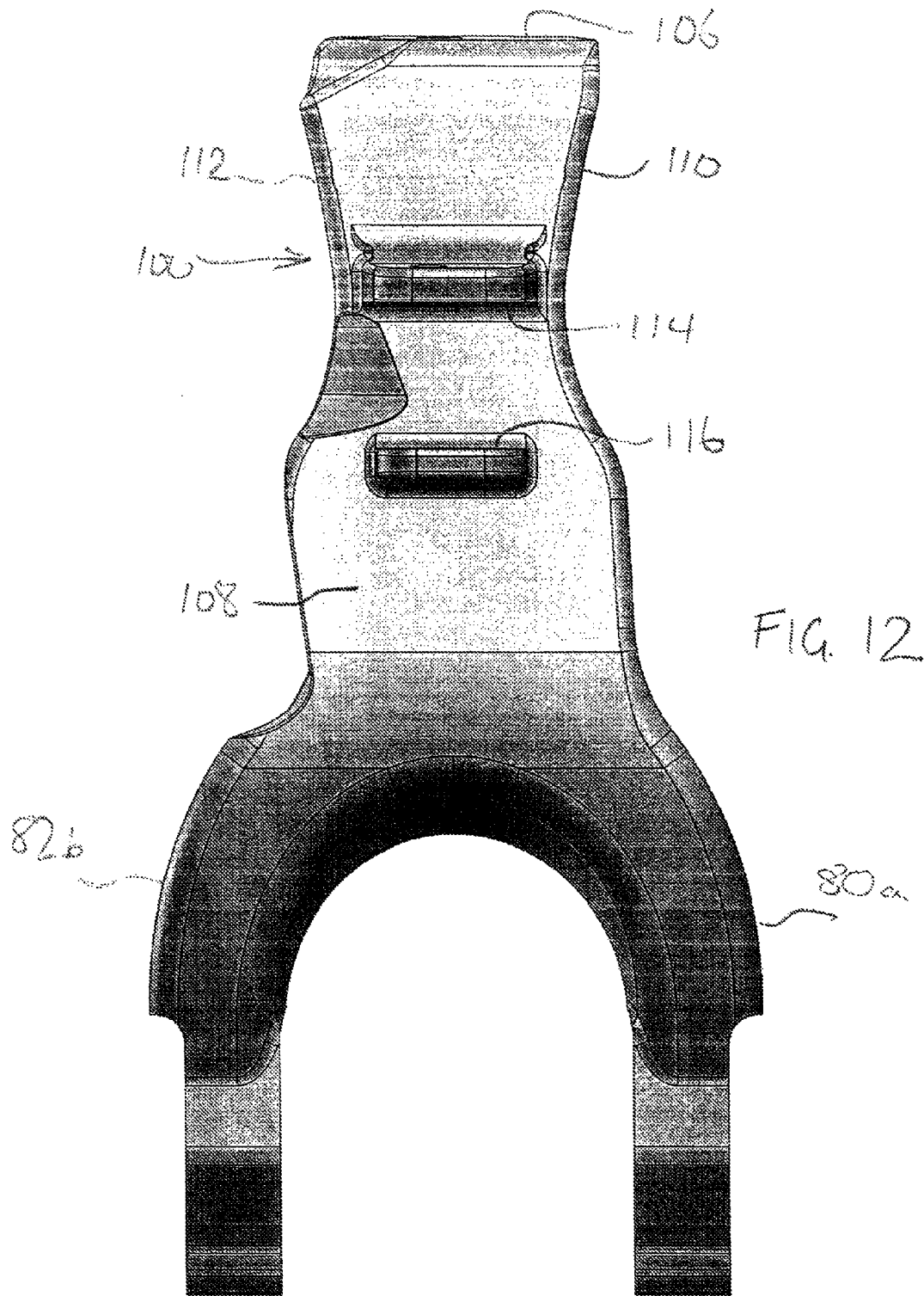


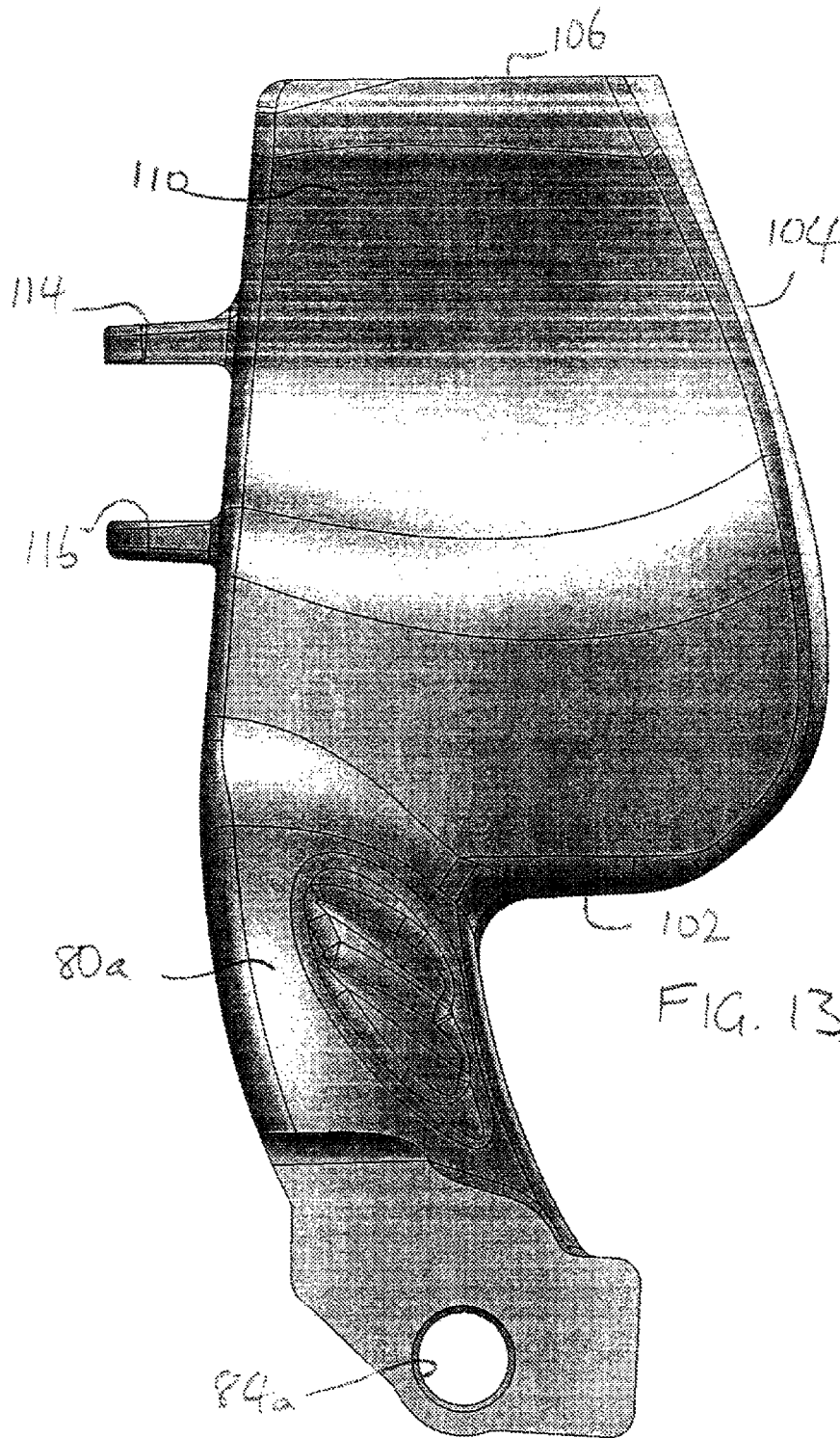


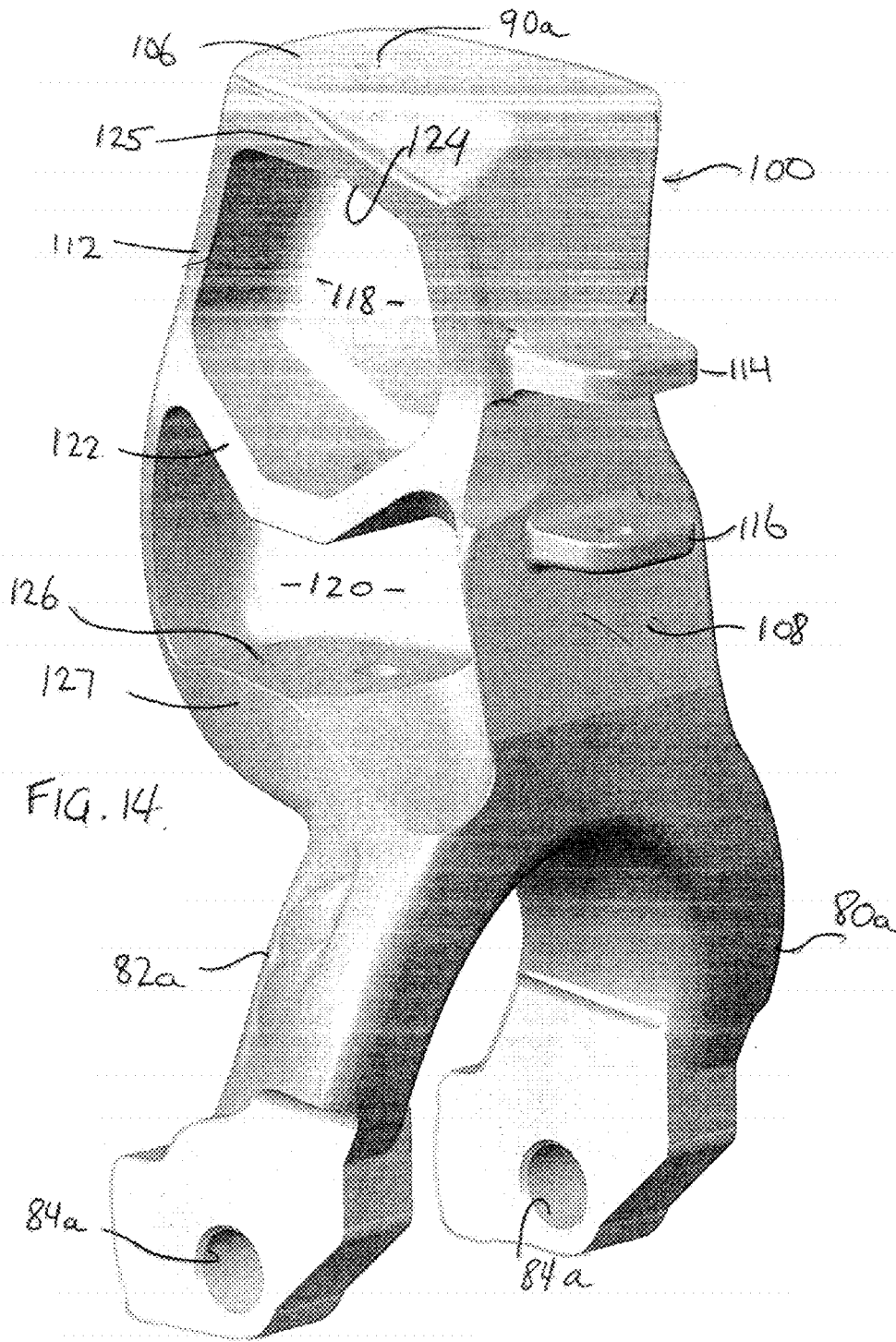












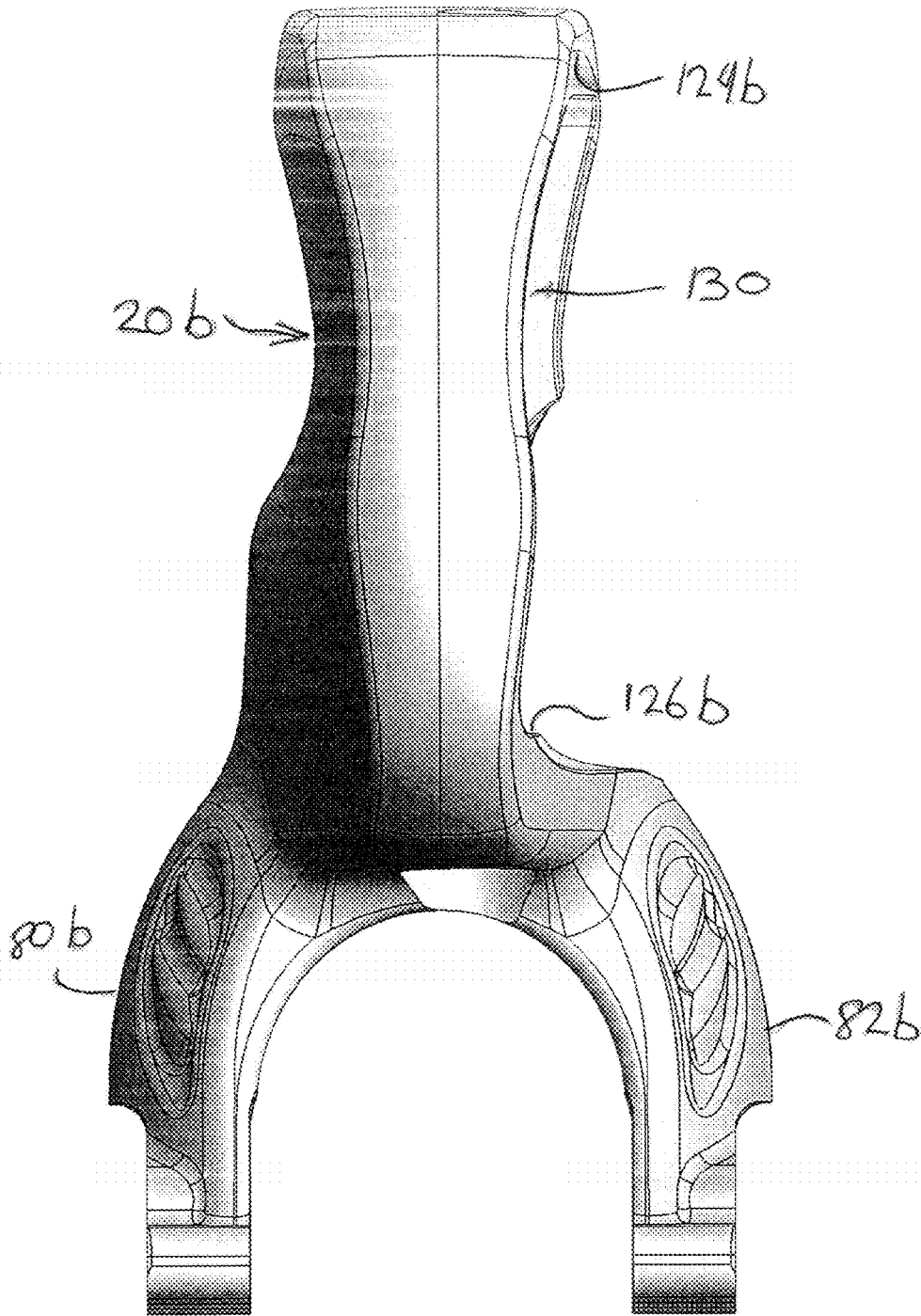


FIG. 15

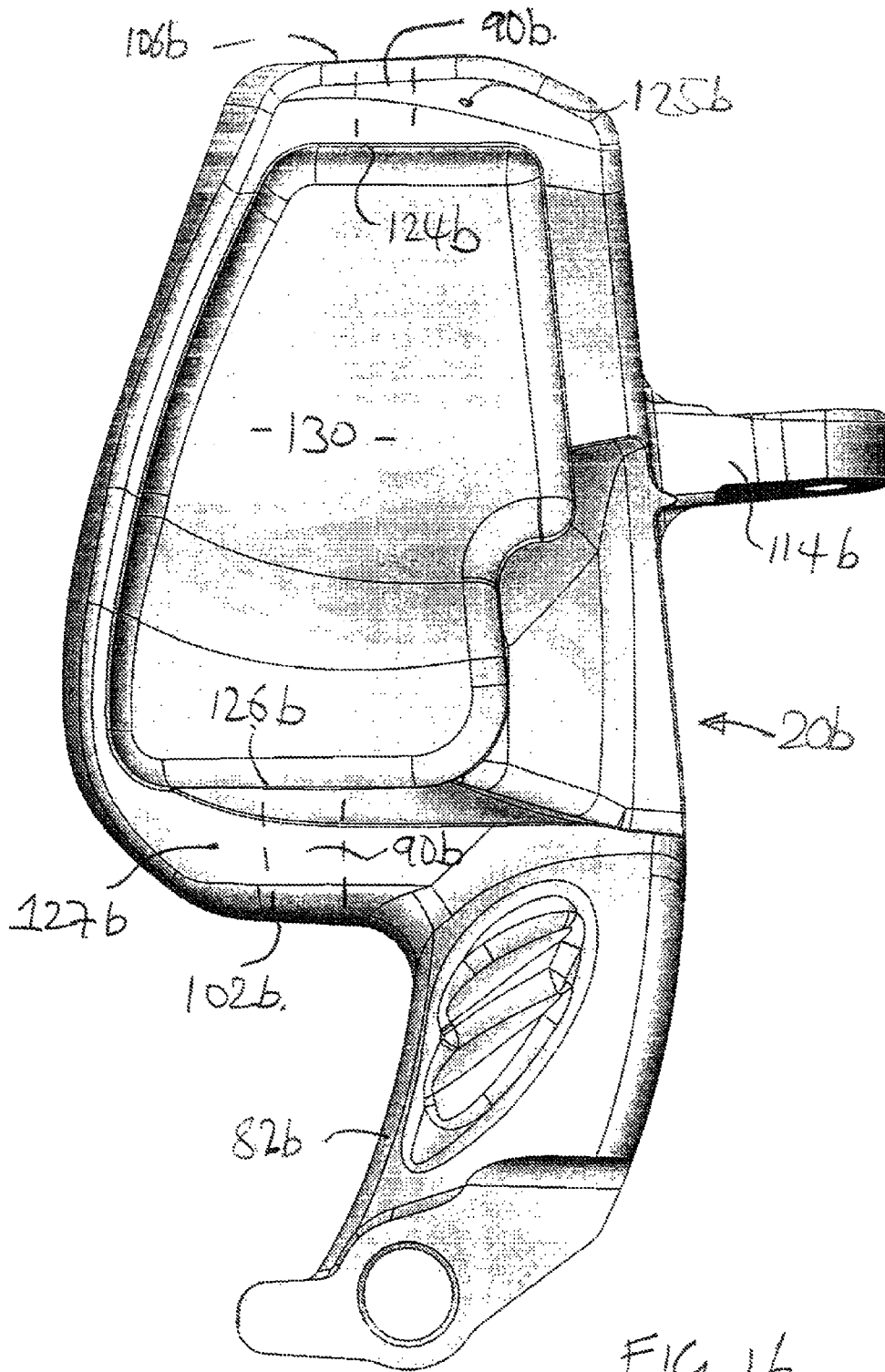


FIG. 16.

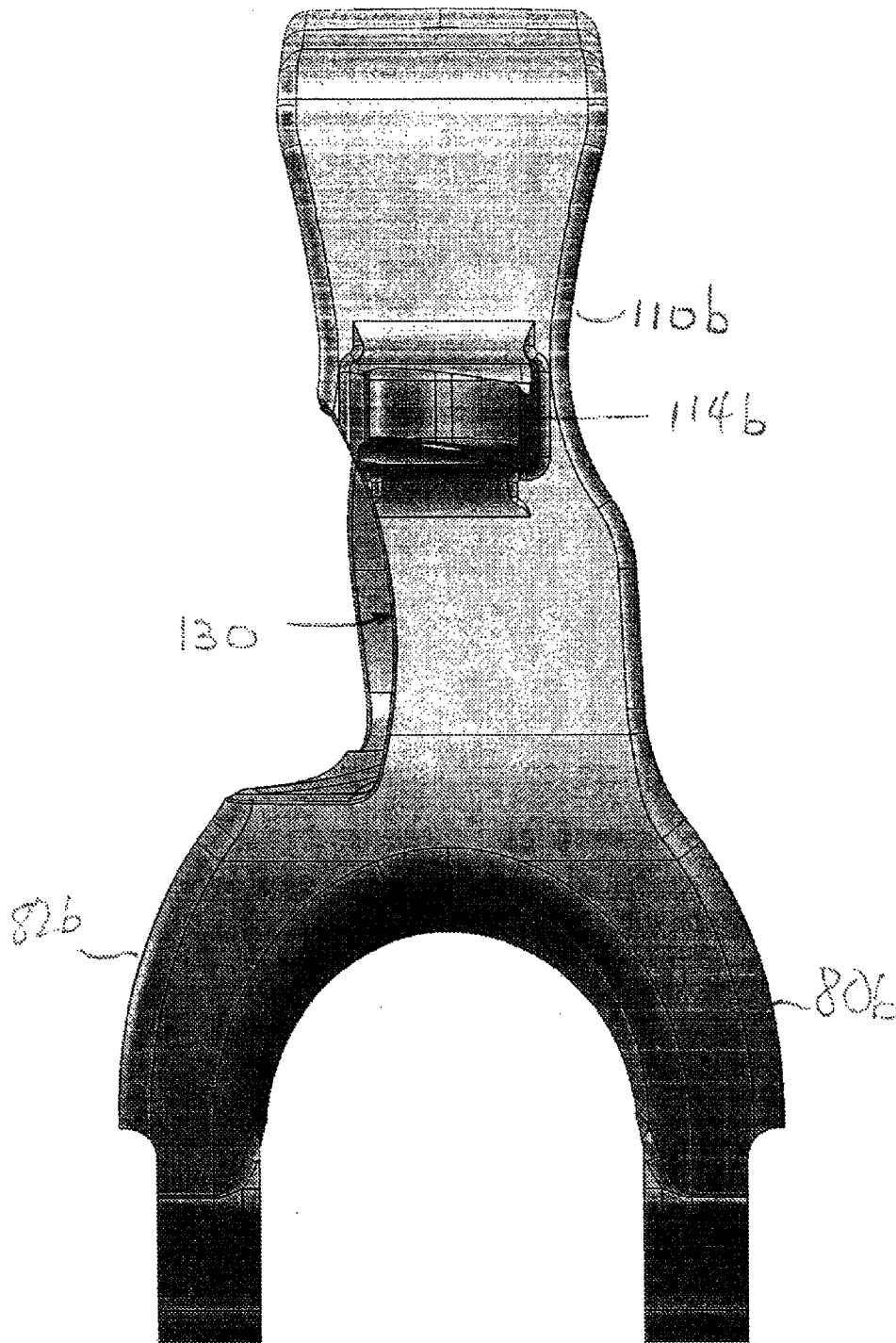


FIG. 17

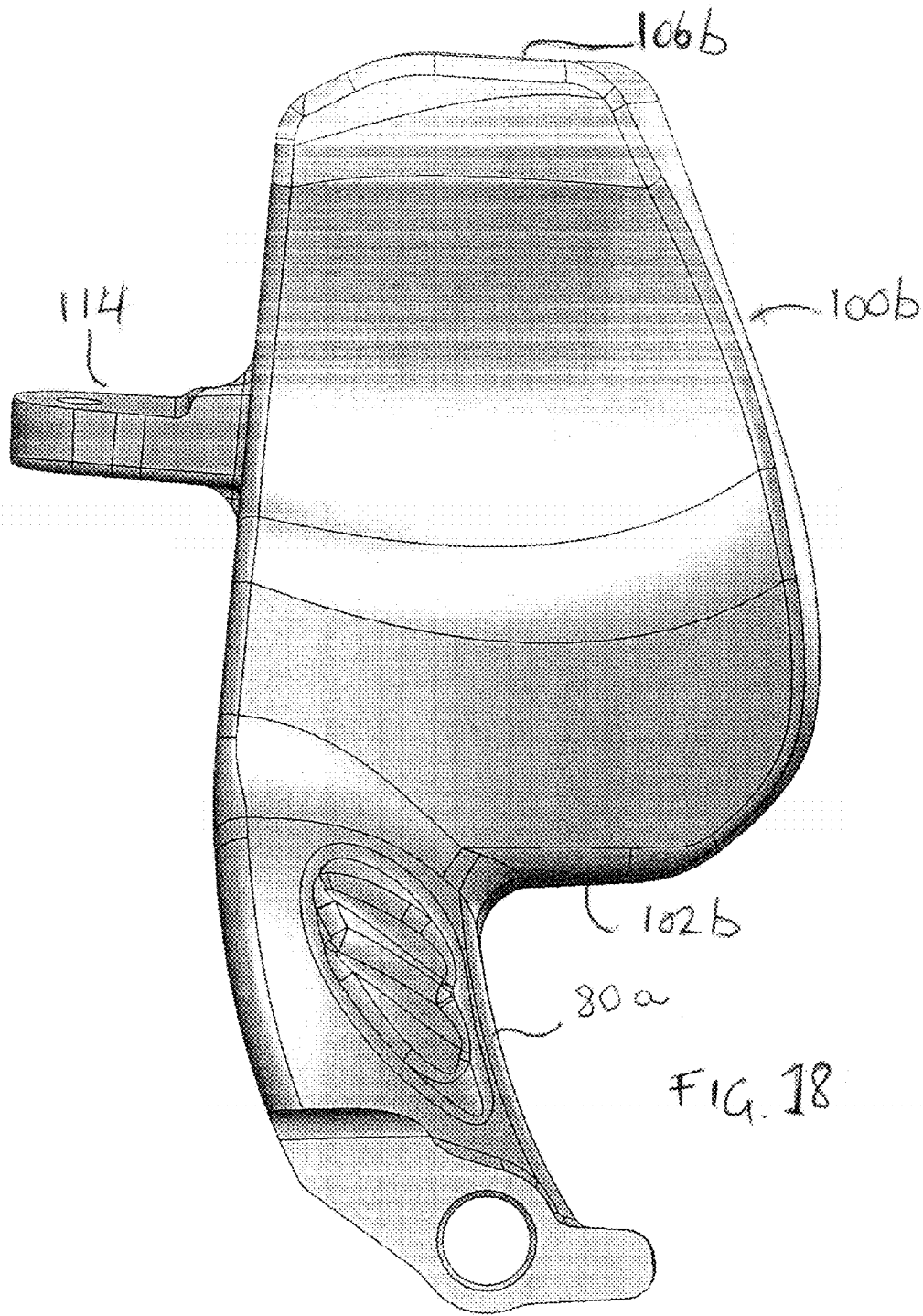
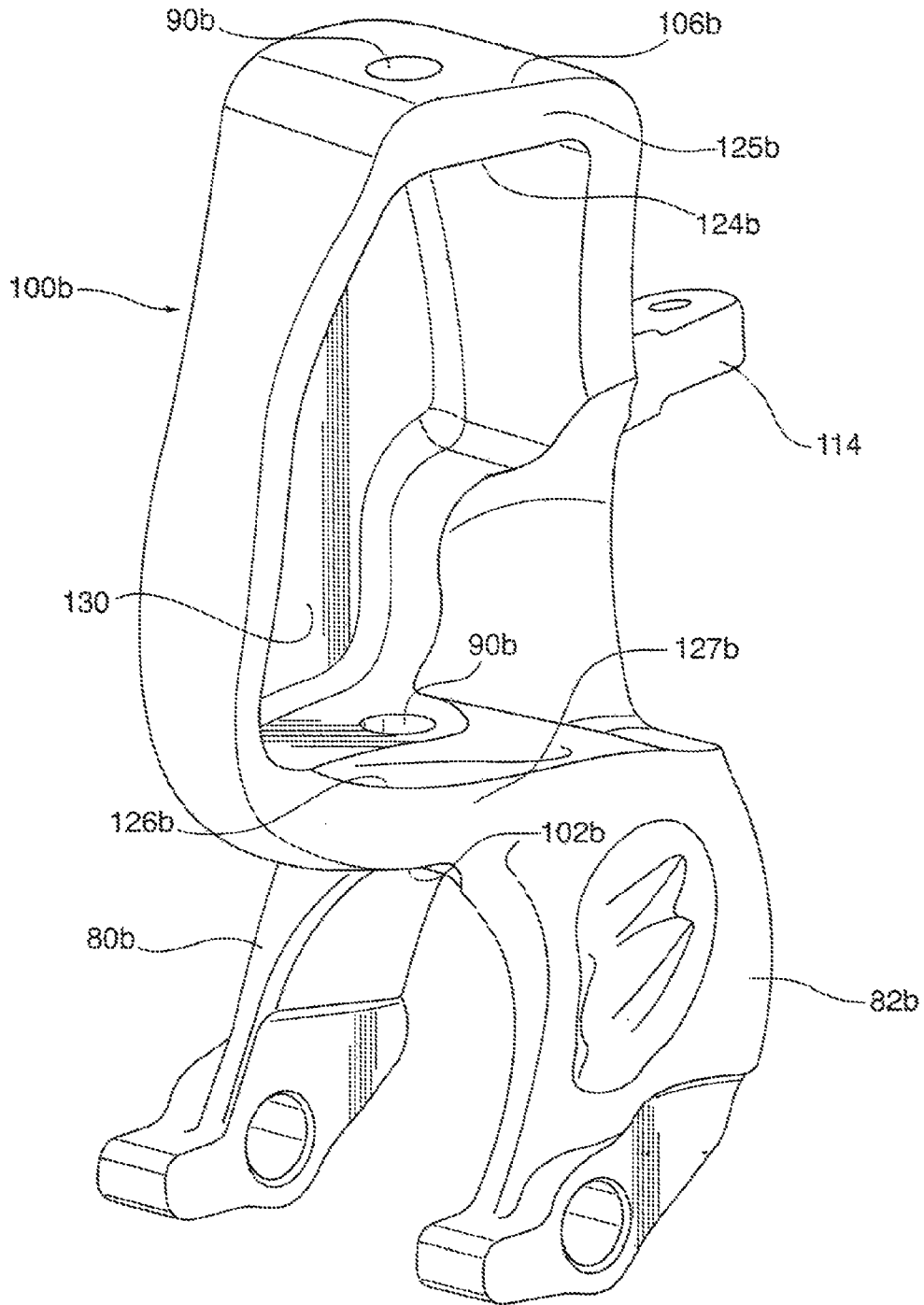
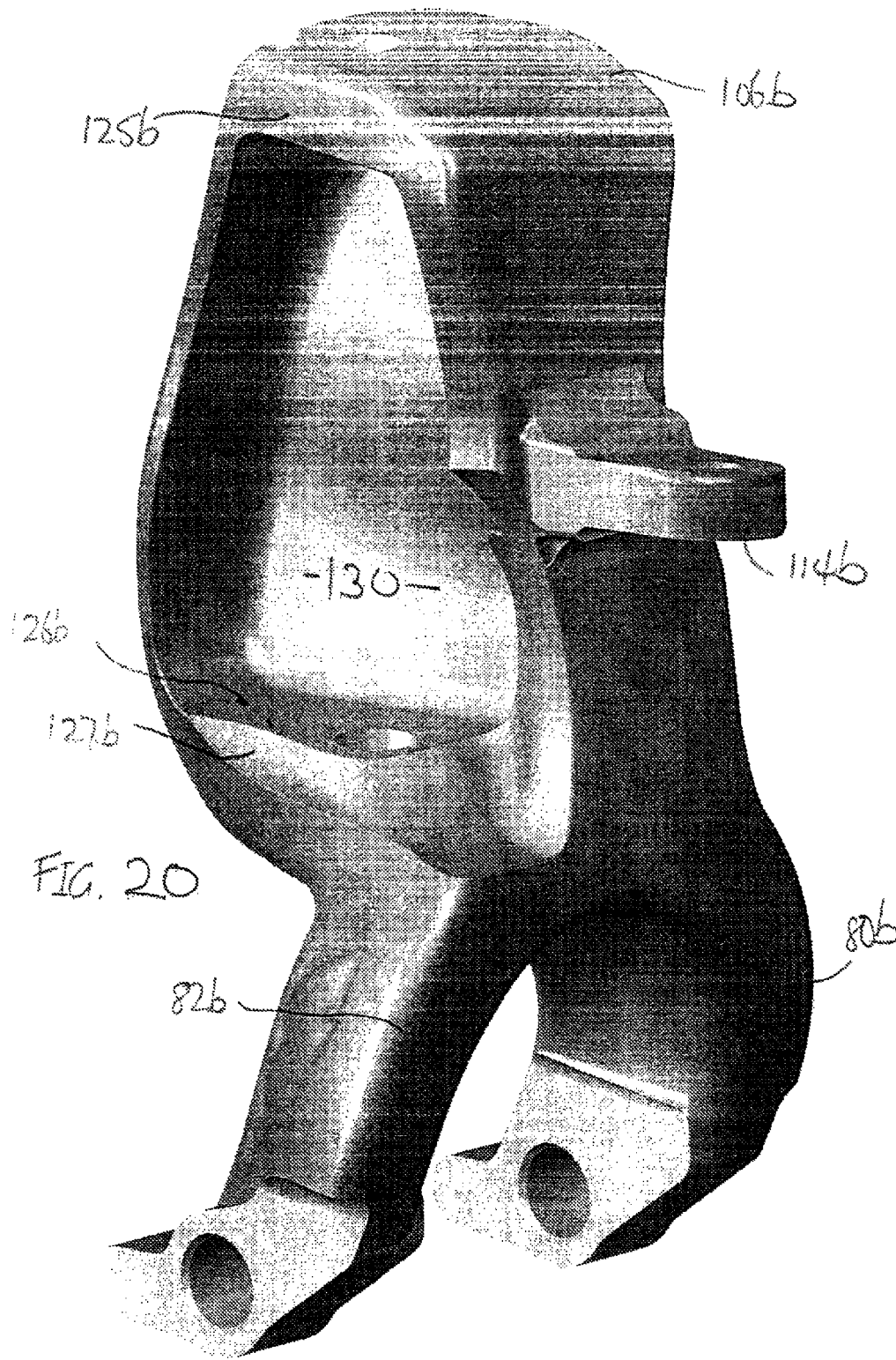


Fig.19





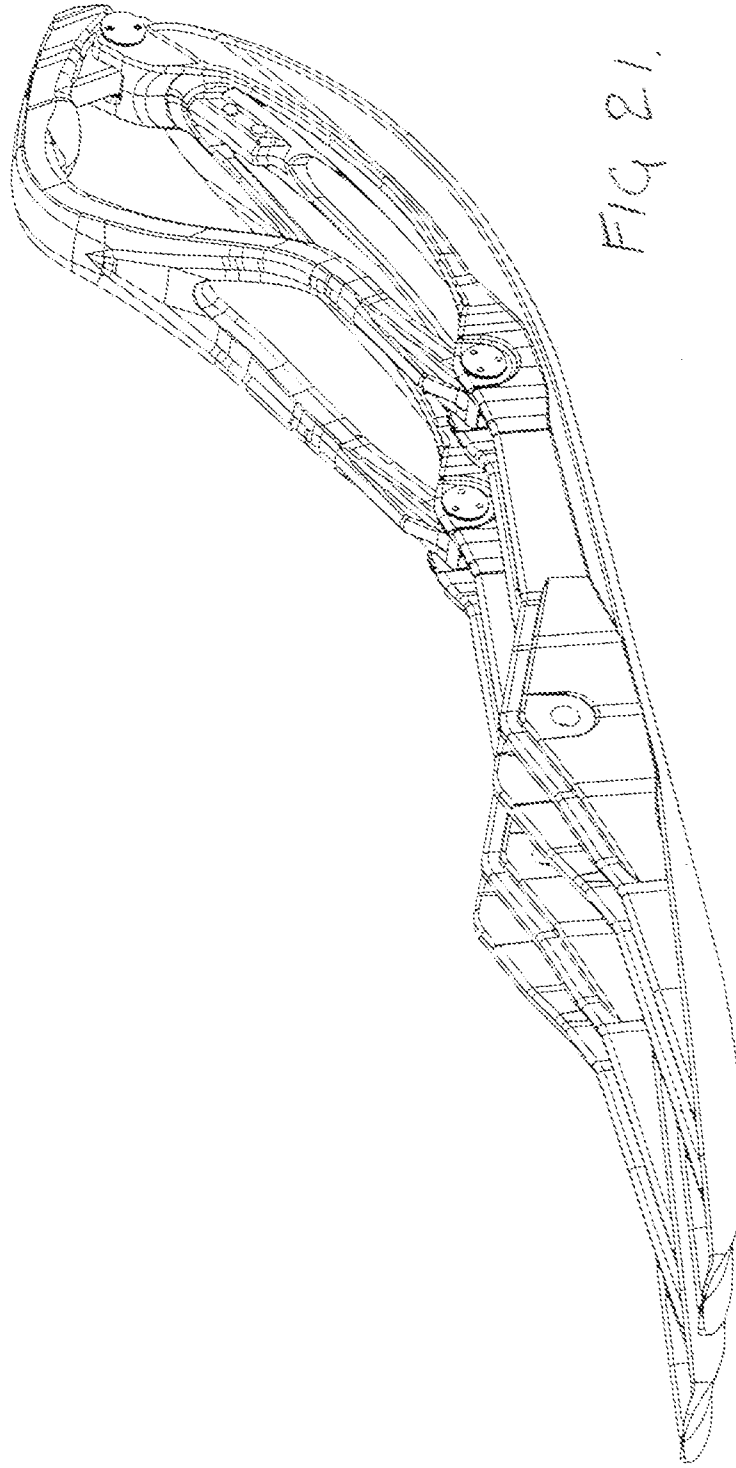


FIG. 21.

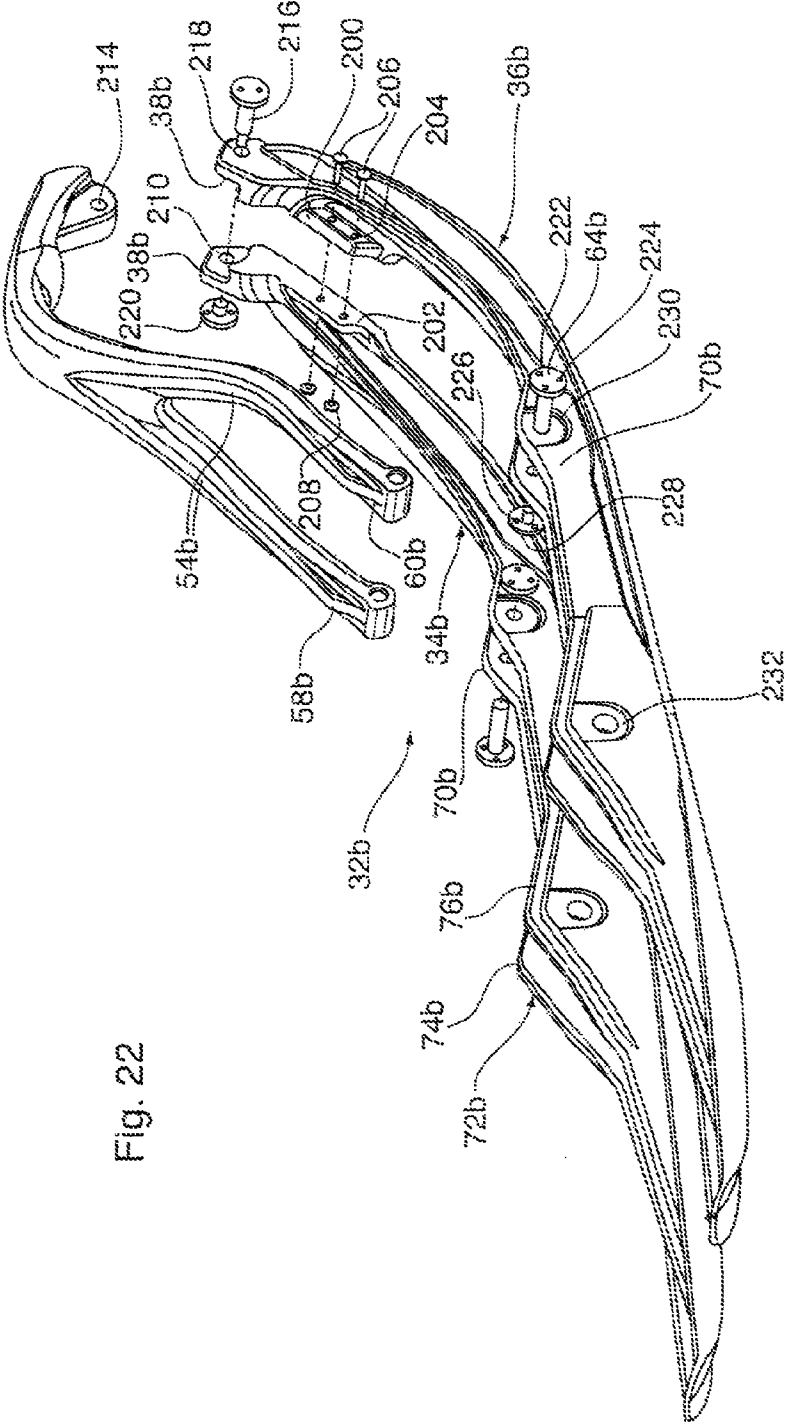


Fig. 22

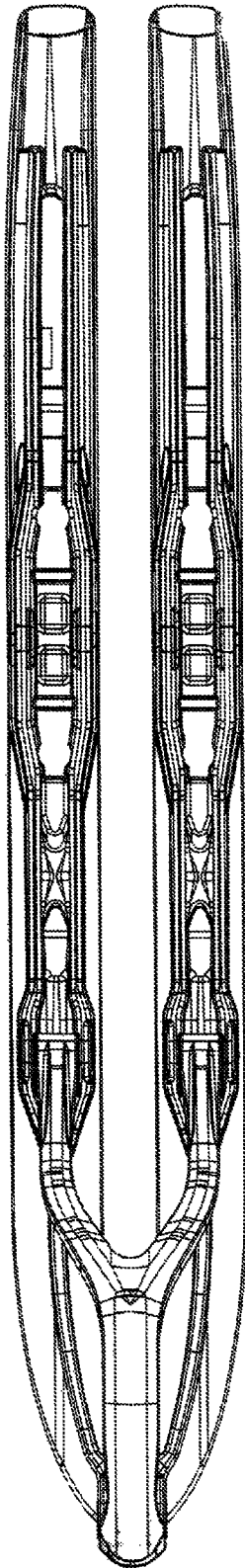


FIG. 23

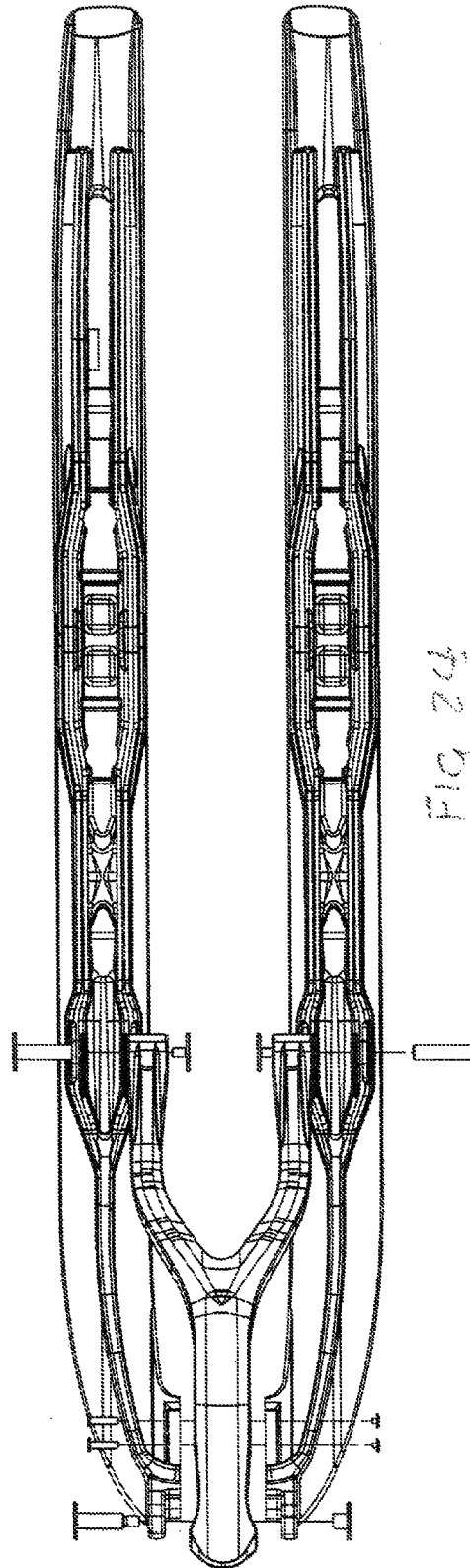


FIG. 24

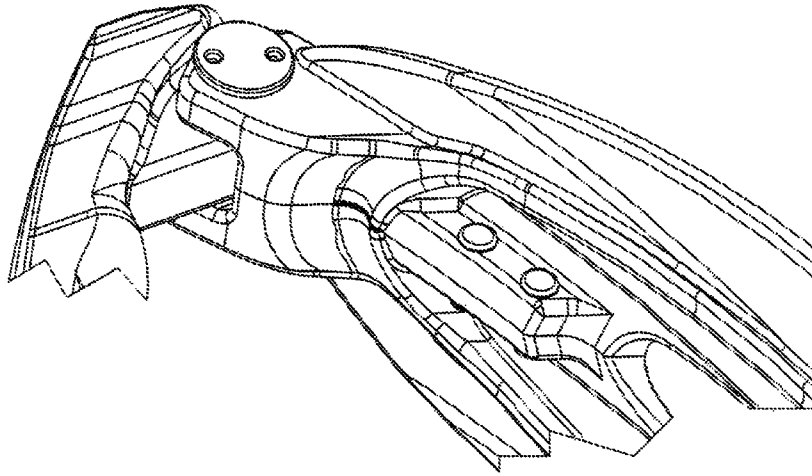


FIG. 26.

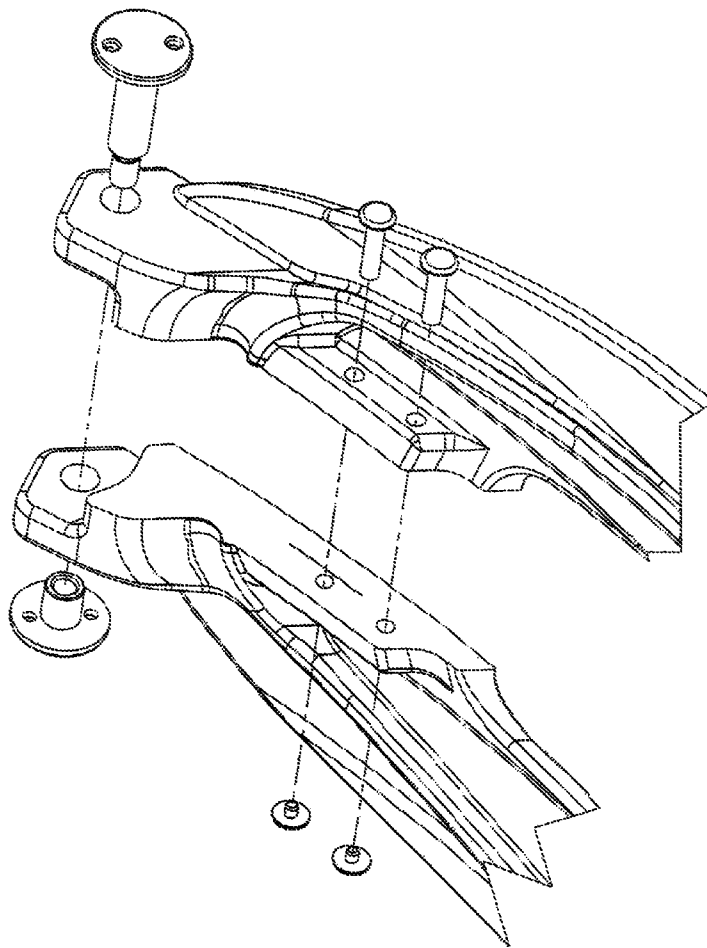
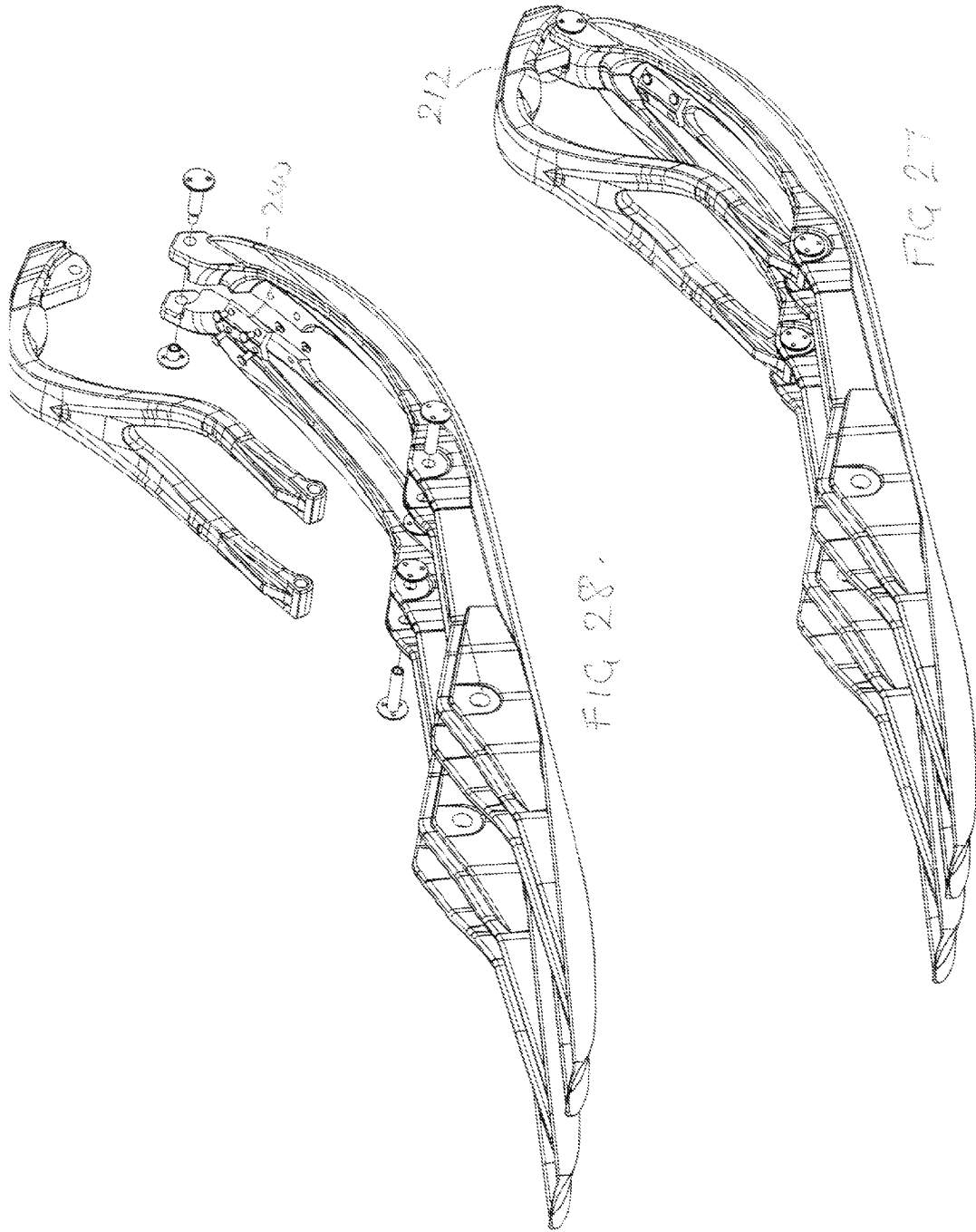


FIG. 25.



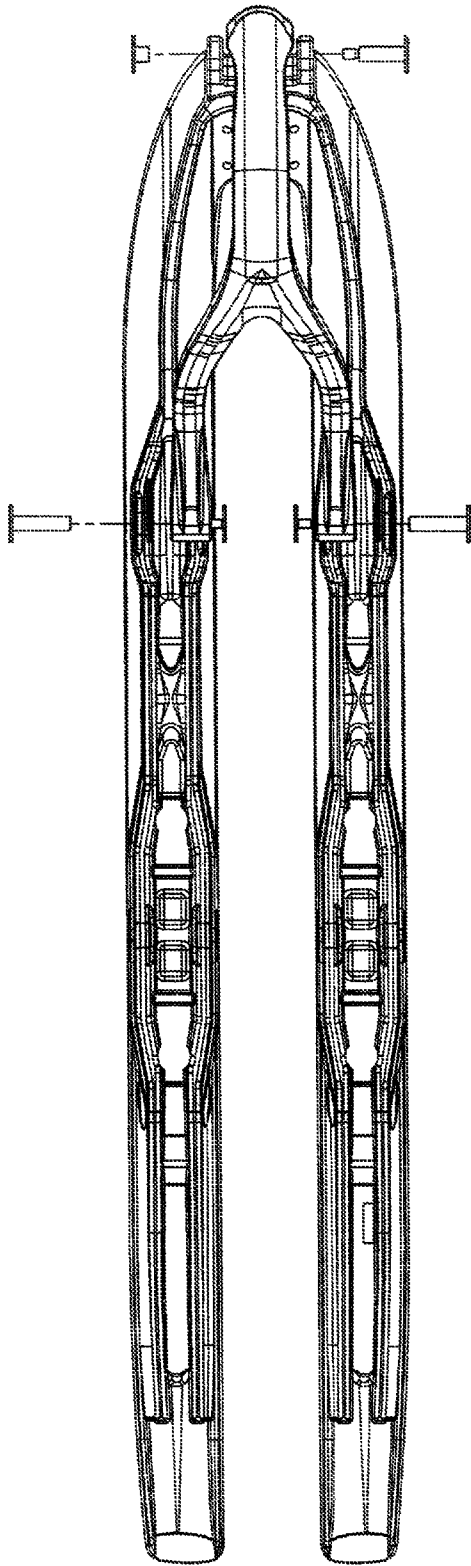


FIG 29

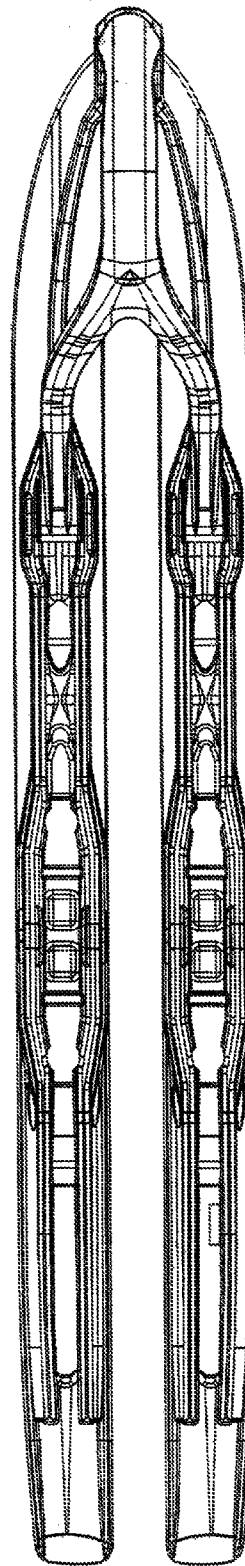
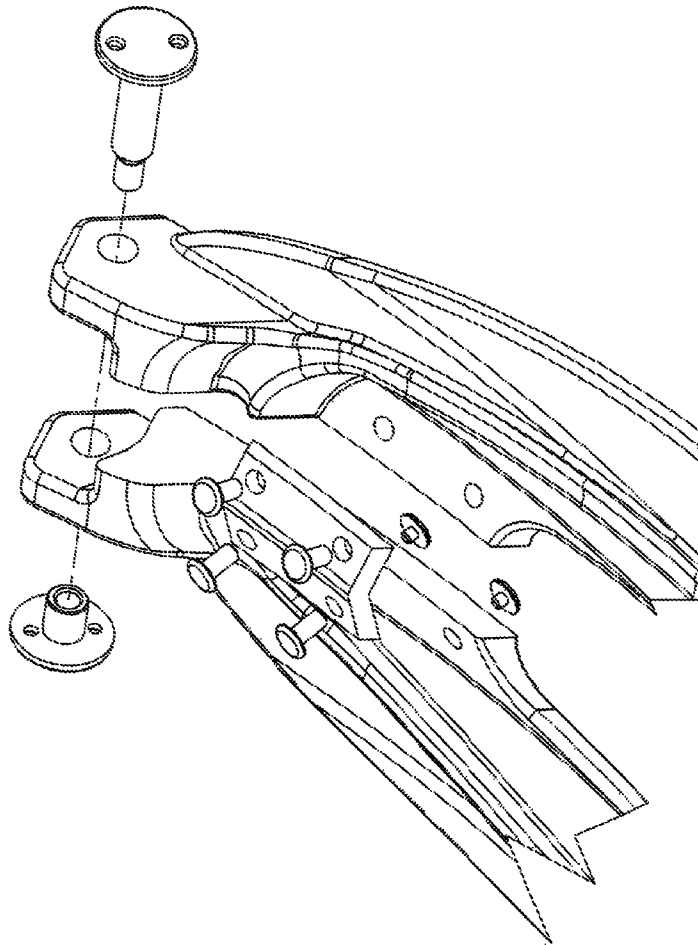
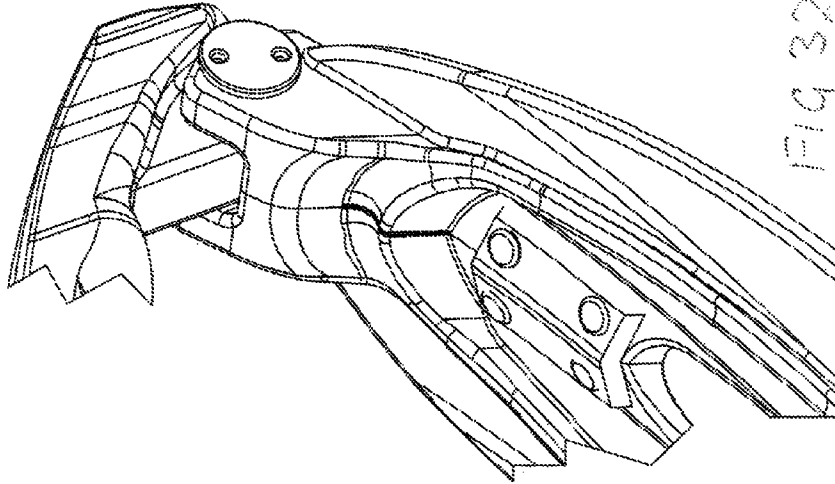


FIG 30



1

SNOWMOBILE AND SUSPENSION ASSEMBLY THEREFOR

CROSS REFERENCE TO RELATED APPLICATIONS

This application is a continuation of U.S. patent application Ser. No. 13/221,293 filed Aug. 30, 2011 which is a continuation-in-part of U.S. patent application Ser. No. 12/046,991 filed Mar. 12, 2008 which claims priority from U.S. Provisional Application No. 60/894,252 filed Mar. 12, 2007 and Canadian Patent Application No. 2,604,041 filed Oct. 22, 2007 and is a continuation-in-part of U.S. patent application Ser. No. 12/906,776 filed Oct. 18, 2010 which claims priority from U.S. Provisional Application No. 61/252,411 filed Oct. 16, 2009; the contents of which are incorporated herein by reference.

FIELD OF THE INVENTION

The present invention relates to snowmobiles in particular to skis for such snowmobiles.

DESCRIPTION OF THE PRIOR ART

The snowmobile is a well known class of machine and is used for transportation over snow. The snowmobiles typically have a belt to provide traction over the snow at the rear of the machine and a pair of ski's at the front of the machine. The skis are steerable so that the operator can steer the snowmobile around the desired course.

Snowmobiles are used in a variety of conditions from ice to fresh snow. As the design of snowmobile has evolved, the skis have themselves become more sophisticated to match the higher performance expectations of the snowmobile. Initially, a single runner was utilized on the underside of the ski to improve lateral traction. However, it was found that a single runner tended to follow the track left by other machines, causing the snowmobile to "dart." A further development used a pair of parallel runners on the underside of the ski. Whilst this mitigates the darting, in certain conditions notably in powder snow, the skis are prone to floating which results in a loss of lateral traction and a resultant loss of steering. This is in part due to the tunnel structure used on the underside of the ski's with the parallel runners. In soft snow, the body of the ski may inhibit the runners from contacting the more solid snow and thereby limit the lateral resistance to that offered by the soft snow.

It is therefore an object of the present invention to provide a ski for a snowmobile in which the above disadvantages are obviated or mitigated.

SUMMARY OF THE INVENTION

In general terms, the present invention provides a snowmobile ski having a bifurcated body. The body is formed from a pair of laterally spaced rails which are interconnected at the tip into a unitary construction. Each of the rails has a runner on the underside. In use, the lateral spacing between the rails permits the snow to pass between the rails and thereby inhibit excessive floating in soft or powder snow conditions.

Preferably, the ski is supported upon on a spindle whose lower portion is bifurcated to provide a pair of legs passage of the snow between the legs of the spindle.

As a further preference, the ski includes a stabilizer bar extending from the tip to a portion of each of the skis forward of the spindle. The distal end of the stabilizer bar is bifurcated

2

to provide a pair of laterally spaced arms to facilitate the passage of snow between the arms of the stabilizer bar.

BRIEF DESCRIPTION OF THE DRAWINGS

An embodiment of the invention will now be described by way of example only with reference to the accompanying drawings in which:

FIG. 1 is a side view of a snowmobile;

FIG. 2 is an exploded perspective view of a ski assembly;

FIG. 3 is a view from the underside of the ski assembly shown in FIG. 2;

FIG. 4 is a view on the line IV-IV of FIG. 3;

FIG. 5 is a view on the line V-V of FIG. 3;

FIG. 6 is a section of a portion of a spindle shown in FIG. 2;

FIG. 7 is a perspective view of a wheel assembly used with the ski assembly of FIG. 2;

FIG. 8 is a front perspective view of a ski shown in FIG. 2;

FIG. 9 is a rear perspective view of the ski of FIG. 8;

FIG. 10 is a front view of an alternative embodiment of spindle;

FIG. 11 is a side view of the spindle shown in FIG. 10;

FIG. 12 is a rear view of the spindle shown in FIG. 10;

FIG. 13 is a side view from the opposite side to the view of FIG. 11;

FIG. 14 is a rear perspective view of the spindle shown in FIG. 10;

FIG. 15 is a front view similar to that of FIG. 10 of a further embodiment of spindle;

FIG. 16 is a side view of the spindle shown in FIG. 15;

FIG. 17 is a rear view of the spindle shown in FIG. 15;

FIG. 18 is a view from the opposite side to that of FIG. 16;

FIG. 19 is a front perspective view of the spindle shown in FIG. 15;

FIG. 20 is a rear perspective view of the spindle shown in FIG. 15;

FIG. 21 is a perspective view of a further embodiment of ski;

FIG. 22 is a view similar to FIG. 21 with the components exploded;

FIG. 23 is a plan view of the ski of FIG. 21;

FIG. 24 is a plan view of the ski of FIG. 2 in exploded form;

FIG. 25 is an enlarged perspective view of a portion of the ski of FIG. 21;

FIG. 26 is a view similar to FIG. 25 with the components assembled;

FIG. 27 is a perspective view of a yet further embodiment of ski;

FIG. 28 is a perspective view showing the components of the ski of FIG. 27;

FIG. 29 is a plan view of the ski of FIG. 27 with the components exploded;

FIG. 30 is a plan view of the ski of FIG. 27 assembled;

FIG. 31 is a detailed perspective view of a forward portion of ski of FIG. 27 showing the components; and

FIG. 32 is a view similar to FIG. 31 showing the components assembled.

DETAILED DESCRIPTION OF THE INVENTION

Referring therefore to the drawings, a snowmobile generally indicated 10 includes a traction drive 12 supporting a superstructure 14. The forward portion of the superstructure 14 is supported on a suspension assembly 16 that includes suspension arm 18 connected to a spindle 20. The spindle 20 is rotatable about a vertical axis relative to the suspension arm

18 and is connected through a steering link 22 to an operator control 24. The lower end of the spindle 20 is connected to a ski assembly 30 shown in greater detail in FIGS. 2 through 5 and 8 and 9.

It will be appreciated that the ski assembly 30 is similar on each side of the snowmobile except as to hand, and therefore only one such ski assembly will be described in detail. The overall dimensions of the skis will vary from machine to machine but will generally be similar to those found on conventional higher performance snowmobiles and constructed from similar materials.

Referring therefore to FIGS. 2, 8 and 9 the ski assembly 30 includes a ski 32 typically moulded from a plastics material. The ski 32 has a body 33 formed with a pair of rails 34, 36 that are laterally spaced from one another over substantially the entire length of the ski body 33. The rails 34, 36 are connected at the tip 38 to provide a unitary construction.

As shown in FIGS. 3 and 4, each of the rails 34, 36 has a under surface 40, 42 respectively that is formed with a concave cylindrical recess 44. The recess 44 is dimensioned to receive a steel runner 46 that is secured in the recess 44 by a bolt (not shown) extending through the body of the rail. The runner 46 has longitudinal slots 48 formed in its lower surface to receive a carbide insert 50. The carbide insert 50 provides a wear resistant insert to the runner 46.

As can best be seen in FIG. 5, the runner 46 extends partially along the under surface 40, 42 of each of the rails 34, 36. The rails 34, 36 are formed with an aperture 52 which permits the runner 46 to pass through the rail from the lower surface 40, 42 to the opposite upper surface. The runner 46 extends toward and across the tip 38 of the ski 32, as shown in dotted lines in FIG. 3, so as to form a continuous runner along each of the rails 34, 36. The continuous runner enhances the strength for high performance.

As best seen in FIG. 2, a stabilizer bar 54 is secured to the tip 38 through a universal joint assembly 56 and extends rearwardly for attachment to the ski. The stabilizer bar 54 is bifurcated so as to provide a pair of arms 58, 60 that progressively diverge in a rearward direction. The distal end of each of the arms 58, 60 is formed with a bushing 62 that receives a connecting bolt 64. The bushing 62 may be elastomeric or steel bushings depending upon the application and the bolts 64 are received in holes 66 formed in spaced upstanding flanges 70 formed on the upper surface of each of the rails 34, 36. A rib 69 extends rearwardly from the tip 38 to the flanges 70. The flanges 70 extend along the rails 34, 36 to provide a socket 72 to receive the spindle 20 and provide a mounting point for the ski body 33. The socket 72 has a pair of laterally spaced walls 74, 76 with reinforced holes 78 integrally formed with the walls 74, 76.

The spindle 20 is bifurcated at its lower end to provide a pair of legs 80, 82 that are received in respective ones of the sockets 72 between the walls 74, 76. The legs 80, 82 have lateral bores 84 for alignment with the reinforced holes 78 to receive connecting bolts 86. The spindle 20 is connected to the suspension arms through mounting holes 90 in conventional manner.

As can best be seen in FIG. 6, legs 80, 82 on spindle 20 terminate in a bore 92 that is asymmetric in cross section. As shown, the bore 92 is part cylindrical with a flat on one side to provide a D shaped cross section. A hole 94 extends through the walls of the bore 92. A wheel assembly indicated 100 in FIG. 7 includes a wheel 102 supported on spindle 104 at the lower end of a vertical leg 106. The vertical leg 106 is dimensioned at its upper end to be received in the bore 92. A hole 110 extends through the leg 106 for alignment with the hole 94 in the legs 80, 82 so that a securing pin 112 may hold the

wheel 100 in situ such that the axle is perpendicular to the length of the ski. Vertical leg 106 has shoulders (not shown) mating with the spindle to support the weight of the machine on the ground, thereby decreasing stress on securing pin 112.

In use on snow, the laterally spaced ski rails 34, 36 provides support for the runner 46. Flotation of the ski body 32 is inhibited by permitting the snow to pass between the ski rails 34, 36 and thereby allow the runner 46 to descend through soft snow to a firmer stratum of packed snow. The bifurcation of the stabilizer bar 56 and the spindle 20 provides a clear passage for the snow through the ski assembly 32 to minimize build up of snow and drag.

The spindle 20 secures the two ski rails 34, 36 to one another whilst permitting limited independent flexure as the ski assembly passes over the snow. The runner 46 contributes to the torsional resilience and bending strength of the ski whilst providing an enhanced contact with the firm or packed snow. A continuous runner is preferred for improved performance but it will be appreciated that a pair of runners may be used, one on each rail 34, 36, for less arduous conditions.

If it is necessary to transport the snowmobile over open ground, the wheel assembly 100 may be inserted between the rails 34, 36 and secured in the bore 92. The locking pin may then be inserted through the holes 94 and 110 to lock the wheels in position below the ski assembly. In this manner, the under side of the skis are elevated from the ground allowing the machine to be rolled along the ground without damage to the skis. The D shaped cross section inhibits rotation of the wheel about a vertical axis with the weight transferred along the spindle 20 so as not to load the locking pin 112.

A further embodiment of spindle is shown in FIGS. 10 through 15 in which like reference numerals to those of FIGS. 1 through 9 will denote like components with a suffix a added for clarity.

Referring therefore to FIGS. 10 through 15, a spindle 20a has a pair of legs 80a, 82a with transverse bores 84a at the lower end of the legs 80a, 82a. The legs 80a, 82a extend downwardly from a head 100. The head 100 has a lower face 102 extending forwardly from the legs 80a, 82a. The lower face 102 merges smoothly with a convex front face 104 that curves rearwardly towards a flat top face 106. A generally linear rear face 108 extends from the top face 106 to the rear of the legs 80a, 82a. A pair of side faces 110, 112 extend between the bottom and top faces 102, 106 and the front and rear faces 104, 108 and, as can be seen in FIGS. 10 through 14, the faces defining the head 100 are smoothly curved to avoid transitional edges.

A pair of tongues 114 extend from the rear face 108 and have holes 116 to permit connection to a steering link.

As best seen in FIG. 11, the inwardly directed side face 112 is contoured to provide a pair of cavities 118, 120. In the embodiment shown in FIG. 11, a web 122 is located between cavity 118 and cavity 120 to extend between the front face 104 and the rear face 108. The upper portion of cavity 118 defines a roof 124 disposed generally parallel to the top surface 106. Similarly, the lower portion of cavity 120 defines a floor 126 disposed generally parallel to the under surface 102. The head 100 therefore has an upper web 125, defined between the roof 124 and top face 106, intermediate web 122 and a lower web 127, defined between the floor 126 and bottom face 106. It will be appreciated that the side surface 112 delimits the lateral extent of the roof 124, web 122 and floor 126 so that those features are contained within the envelope of the head 100.

Holes 90a are formed in the upper web 125, the intermediate web 122 and the lower web 127. The holes 90a provide mounting points for the suspension elements shown in

ghosted outline on FIG. 11. Thus the upper suspension element U is secured above the upper web 125 and the lower suspension element L is secured between the intermediate web 122 and the lower web 126 within the cavity 120. The rear portion of the cavity 120 is contoured, as indicated at 130, to facilitate the required range of movement of the spindle on the suspension element.

It will be appreciated that the spindle 20a is handed so that a mirror image of the spindle shown in FIGS. 10 through 14 is provided for the opposite side of the snowmobile.

In operation, the legs 80a, 82a are connected to the mounting points on respective ones of the skis 32 and the suspension elements connected to the holes 90a. The legs 80a, 82a support the rails 34, 36 whilst allowing snow to pass through the spacing between the rails and through the bifurcated legs 80a, 82a of the spindle 20a. The smoothly contoured head 100 provides an aerodynamic structure to support the suspension elements and encompasses those elements within the cavities 118, 120.

A further embodiment is shown in FIG. 15 through 20 in which like components will be identified with like reference numerals with the suffix "b" added for clarity. In the embodiment of FIGS. 15 through 20, the spindle 20b is formed with a single cavity 130 so as to define a roof 124b and floor 126b. The roof 124b defines an upper web 125b between the top surface 106b and the roof 124b and, similarly, a lower web 127b is defined between the floor 126b and the under surface 102b.

The cavity 130 is sized to permit a suspension element shown in ghosted outline to be secured within the cavity 130 through attachment points 90b. The upper suspension element U, again shown in ghosted outline is secured to the web 125b.

A single flange 114b is provided for connection to the steering link so that, with the legs 80b, 82b connected to the skis 32 and to the suspension and steering elements, the spindle 20b is operable to support the ski in normal use and impart steering motions to them.

In both embodiments, the head 100 may be cast and/or forged and the configuration of the cavities 118, 120, 130 machined to suit the mounting points and suspension elements of existing vehicles. In this manner, the basic configuration of the spindle 20a may be used in a variety of applications. It will also be noted that the outer face 110 forms a continuous web forming the rear face of the cavities 118, 120, 130 thereby adding to the rigidity of the head in use.

A further embodiment of ski is shown in FIGS. 21 through 26 in which like components will be identified with a like reference numeral with a suffix "c" added for clarity. The ski of the embodiment of the FIGS. 21 through 26 may be used with either of the spindles shown in FIGS. 10 through 20, or with the spindles shown in FIGS. 1 through 6.

The overall configuration of the ski assembly 30c is similar to that shown in FIGS. 8 and 9. However the body 33c is formed as separate rails 34c, 36c, that are mechanically connected to one another, rather than the integrally moulded body 33 of FIGS. 8 and 9. In the embodiment of FIGS. 21 through 26, each of the rails 34c, 36c is separately moulded and each has an upstanding flange 200 adjacent its tip 38c. The flange 200 presents a planar face 202 for an abutment with a similar face on the flange 200 of the adjacent rail. Holes 204 are formed in the web 200 to receive bolts 206. The bolts pass through the holes 204 in each of the webs 200 and are secured by nuts 208.

An arcuate rabbet 210 is formed at the tip of each of the rails 34c, 36c to define a groove 212 at the forward extremity of the body 33c. The groove 212 receives a tongue 214 of the

stabilizer 54c which is secured to the body 33c by a bolt 216 passing through aligned holes 218. A nut 220 secures the bolt to the body 33c and secures the tongue 214 within the groove 212.

The stabilizer bar 54 has a pair of bifurcated arms 58c, 60c that extend rearwardly to be received between the flanges 70c. A bolt 64c secures the arms 54c, 58c to the flanges 70c.

Each of the bolts 64c is received in holes 66c to extend between the flanks 70c. The bolt 64c is formed with a disk shaped head 222 with circular holes 224 to receive pegs of a wrench. A complementary nut 226 secures the bolt 64c within the hole 66c and also has a disk shaped head 228.

The outwardly directed faces of the flanges 70c, are formed with a recesses 230 to accommodate the head 224 and the nut 226. The depth of the recess 230 corresponds to the thickness of the disk forming the head 224 or nut 226 so that a smooth exterior surface is provided to the flanges 70c when the bolts 64c are installed. Entrapment of snow as it passes between and around the skis is thus avoided.

Similarly, the laterally spaced walls 74c, 76c of the sockets 72c for attachment to the spindle are formed with recesses 232 to accommodate circular heads of the bolt securing the spindle to the ski. Again, therefore, a smooth exterior surface is provided to inhibit build-up of snow around the connection of the spindle to the ski.

The rails 34b, 36b are moulded from a suitable plastics materials, such as high molecular weight polypropylene, and are connected by bolts 206 at the tips to form a ski body 33c. The stabilizer bar 54c is then connected to the tip of the ski body 33c through the bolt 216 and the arms 58c, 54c connected through the bolts 64c to the flanges 70c. The body 33c may then be connected to the legs of a spindle through bolts passing through the holes 78c formed in the sockets 72c.

A further embodiment of ski body is shown in FIGS. 27 through 32 and like reference numbers will be used to identify like components with a suffix "d" added for clarity.

In the embodiment of FIG. 27, rails 34d, 36d are moulded as separate components. Webs 200d are formed adjacent the tip of the rails 34d, 36d and holes 204d provided to extend in a vertical direction. A connecting bracket 240 bridges the webs 200 with connecting bolts 206 to secure the bridging piece 240 to each of the rails 34d, 36d.

The stabilizer bar 54d is connected to the tip as described above with respect to FIG. 22 and received between the flanges 70d in a similar manner. Again therefore the rails 34d, 36d may be formed as separate components and subsequently secured to one another to provide the ski body 33d.

In each embodiment of ski body the lateral spacing of the rails 34, 36 and the bifurcated legs of the stabilizer arm and spindle facilitate the passage of snow along the ski. In the embodiments of FIGS. 22 through 32, the recesses formed in the flanges 70 allow the heads of the connecting bolts to be flush with the exterior surface of the ski rails and further inhibit the build-up of snow in operation.

The invention claimed is:

1. A snowmobile comprising a superstructure supported at one end on a drive belt to provide a traction drive, and at an opposite end on a suspension assembly, said suspension assembly including a pair of steerable ski assemblies laterally spaced relative to said superstructure and connected to said superstructure by respective suspension arms, each of said ski assemblies including a spindle rotatably mounted to said suspension arm for movement about a steering axis and connected to a steering control to effect steering of said snowmobile, and a ski connected to said spindle for movement about a transverse axis, each of said skis including a body with a pair of rails spaced from one another to define an

7

elongate gap through which snow may pass from the under-
side of each ski to the top side, said rails being connected at
their tip to provide a unitary structure, and each of said
spindles is bifurcated to provide a pair of legs, each connected
to a respective one of said rails, said skis being positioned on
said snowmobile to permit flow of snow through said gap
upon movement of said snowmobile over snow and said legs
and said rails being aligned to provide an unimpeded passage
of snow between said rails and legs when said snowmobile is
driven by said belt.

2. A snowmobile according to claim 1 wherein each of said
ski assemblies includes a stabilizer bar extending from said
tip to each of said rails.

3. A snowmobile according to claim 2 wherein said stabi-
lizer is bifurcated to provide a pair of arms to facilitate pas-
sage of snow between said rails.

4. A snowmobile according to claim 1 wherein said spindle
includes a head and said legs depend from said head, said
suspension arm being rotatably connected to said head.

8

5. A snowmobile according to claim 4 wherein a steering
link is connected to said head at a location offset from said
suspension arm and is operably connected to said steering
control.

6. A snowmobile according to claim 5 wherein a pair of
suspension arms are connected to said head.

7. A snowmobile according to claim 1 wherein said legs are
received in sockets formed on the top side of said ski.

8. A snowmobile according to claim 7 wherein said leg is
pivotally connected to said socket for rotation about a trans-
verse axis.

9. A snowmobile according to claim 8 wherein said sockets
are formed by a pair of upstanding walls and a pin extends
between said walls and through said leg.

10. A snowmobile according to claim 1 wherein a runner is
provided under each of said rails to provide a pair of laterally
spaced runners for each of said skis.

* * * * *